

## Chapter Three

# Engineering Geometry

The senses delight in what is truly proportional.

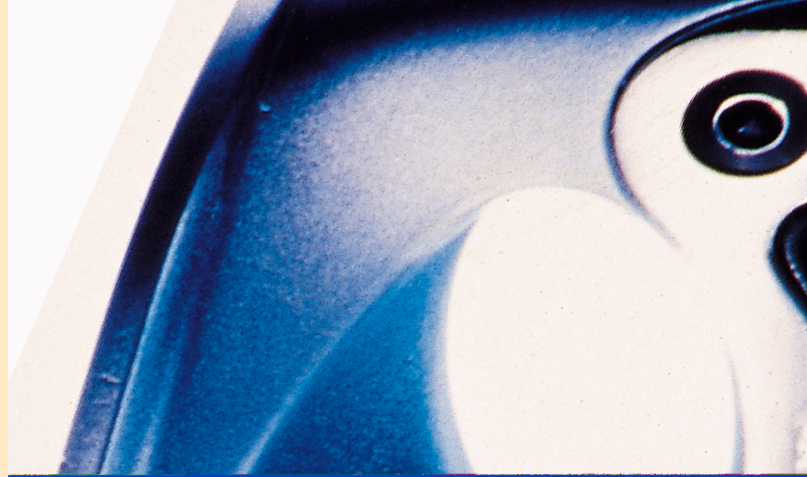
**Thomas Aquinas**

### Objectives and Overview

Graphics is used to represent complex objects and structures that are created from simple geometric elements, such as lines, circles, and planes. Current 3-D CAD programs use these simple geometric forms to create more complex ones, through such processes as extrusion, sweeping, and Boolean solid modeling operations. To fully exploit the use of CAD, you must understand geometry and be able to construct 2-D and 3-D geometric forms.

This chapter introduces the geometric forms useful in engineering design, from the simple to the complex. The chapter defines four engineering geometry categories, from simple 2-D elements to complex 3-D forms. The geometric elements and forms that are the basic components of engineering geometry are defined and illustrated, along with the application of these elements to engineering design. In addition, geometric conditions are defined and illustrated, and geometric construction techniques that are useful for engineering design are described.

The chapter is divided into two major sections: geometric construction and engineering geometry. Many of the geometric construction techniques described apply only to hand tools, because many CAD systems have commands that per-



form some of the steps automatically. However, the construction techniques are still valuable because the terminology and the descriptions of the various geometric forms are applicable to CAD. CAD systems become even more powerful in the hands of someone who understands 2-D and 3-D geometric forms.

*After completing this chapter, you will be able to:*

1. Describe the importance of engineering geometry in the design process.
2. Describe coordinate geometry and coordinate systems and apply them to CAD.
3. Explain the right-hand rule.
4. List the major categories of geometric entities.
5. Explain and construct the geometric conditions that occur between lines.
6. Explain and construct tangent conditions between lines and curves.
7. Explain and construct conic sections, roulettes, double-curved lines, and freeform curves.
8. List and describe surface geometric forms.
9. Describe engineering applications of geometry.
10. Describe two types of 3-D modeling.

### 3.1 Engineering Geometry

Geometry provides the building blocks for the engineering design process. **Engineering geometry** is the basic geometric elements and forms used in engineering design.

In this chapter, traditional and CAD-based geometric construction techniques are introduced, along with the primitive geometric forms that serve as the building blocks for more complicated geometric shapes commonly found in engineering design. Some of the more advanced surface geometry topics covered in this chapter introduce geometric forms that can be created by 3-D surface modeling CAD programs.

### 3.2 Shape Description

Engineering and technical graphics are concerned with the descriptions of shape, size, and operation of engineered products. The **shape description** of an object relates to the positions of its component geometric elements in space. To be able to describe the shape of an object, you must understand all of the geometric forms, as well as how they are graphically produced.

Shape description is based on the primitive forms, points, lines, and planes, which are combined to create more complex forms, such as that shown in Figure 3.1.



**Figure 3.1**

#### Shape description

Complex engineering geometry is found in many engineered products, structures, and systems.

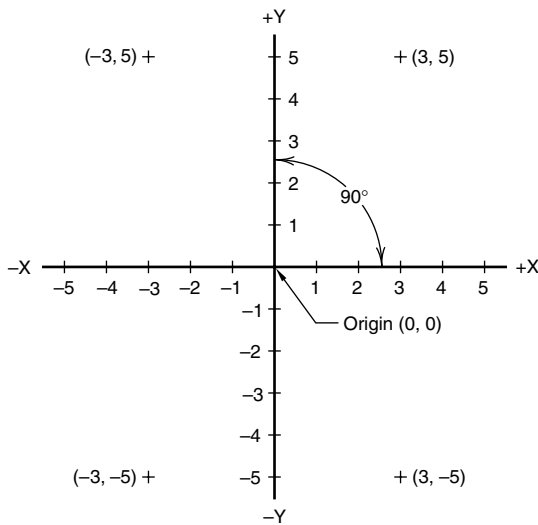
(© Ron Sherman: Stone.)

A shape description is developed through orthographic, pictorial, or other projection techniques.

### 3.3 Coordinate Space

In order to locate points, lines, planes, or other geometric forms, their positions must first be referenced to some known position, called a **reference point** or origin of measurement. The **Cartesian coordinate system**, commonly used in mathematics and graphics, locates the positions of geometric forms in 2-D and 3-D space. This system was first introduced in 1637 by the French mathematician René Descartes (1596–1650). The coordinate geometry based on this system theorizes that, for every point in space, a set of real numbers can be assigned, and for each set of real numbers, there is a unique point in space.

A 2-D coordinate system establishes an **origin** at the intersection of two mutually perpendicular axes, labeled X (horizontal) and Y (vertical) (Figure 3.2). The origin is assigned the coordinate values of 0,0. Values to the right of the origin are considered positive, and those to the left are negative. Similarly, values above the origin are positive, and those below are negative. Using this convention,



**Figure 3.2**

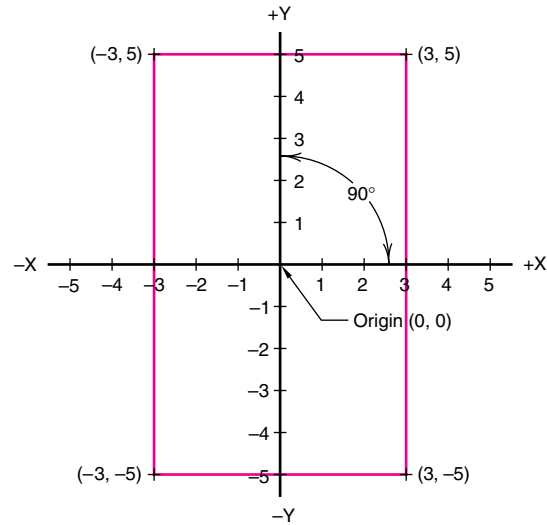
#### 2-D Cartesian coordinate system

The 2-D Cartesian coordinate system was developed by René Descartes to locate the positions of geometric forms in space.

you can locate any point in 2-D space by assigning a unique set of numbers to that point. The numbers assigned to each point are called **coordinates**, where the first number is the X coordinate and the second number is the Y coordinate. For example, the coordinates 3,5 would locate a point in the upper right quadrant of the 2-D coordinate system, as shown in Figure 3.2. Coordinates of  $-3,5$  would locate a point in the upper left quadrant; coordinates of  $-3,-5$  would locate a point in the lower left quadrant; and coordinates of  $3,-5$  would locate a point in the lower right quadrant. By connecting these points with lines, you create a rectangle in fixed coordinate space (Figure 3.3).

In a 3-D coordinate system, the origin is established at the point where three mutually perpendicular axes (X, Y, and Z) meet (Figure 3.4). The origin is assigned the coordinate values of 0,0,0. By convention, values to the right of the origin are positive, and those to the left are negative; values above the origin are positive, and those below are negative; and values in front of the origin are positive, and those behind are negative.

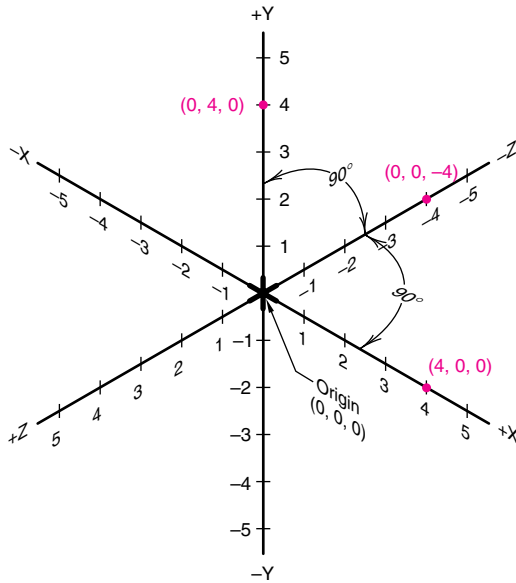
Using this convention, you can assign a unique triplet of ordered numbers to any point in 3-D space. The first number represents the X distance, the second number the Y distance, and the third number the Z dis-



**Figure 3.3**

#### Locating points

A rectangle is created by using coordinate values for each corner and then drawing the connecting lines.

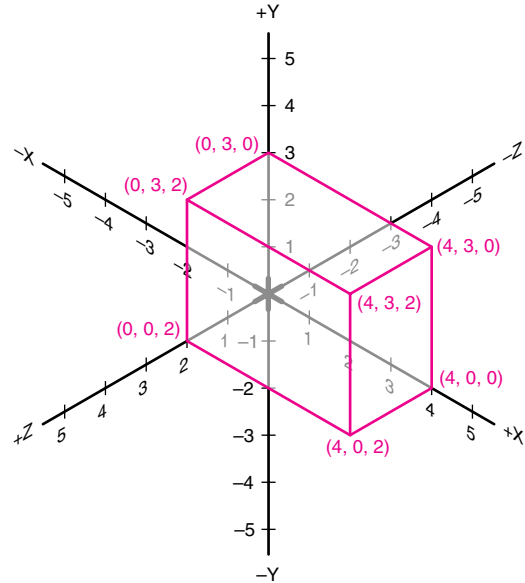
**Figure 3.4****3-D coordinate system**

The 3-D coordinate axes consist of three mutually perpendicular axes. The red numbers in parentheses are example coordinate values at the marked locations.

tance. Figure 3.5 shows a rectangular prism located in 3-D coordinate space, with the following values for the corners. Notice in Figure 3.5 the coordinate triplets in parentheses given for each of the corners of the rectangular prism.

This coordinate system is used in multiview drawings and 3-D modeling, using both traditional tools and CAD. Figure 3.6 is a multiview drawing of an object, with coordinate axes displayed in each viewport. The front viewport shows the X and Y axes, with Z as a point; the top viewport shows the X and Z axes, with Y as a point; and the profile viewport shows the Y and Z axes, with X as a point. By “placing” the lower left-front corner of the block on the origin, you can then locate all other points on the block by their coordinates. For example, point A in the figure is located at coordinates 3,3,-1.

CAD systems provide a method for displaying the cursor’s current position in coordinate space. Normally, there is some type of toggle switch or command that turns on the coordinate tracking, which is then displayed at the top or bottom of the screen (Figure 3.7). To create 3-D models, most CAD systems use 2-D input devices, such as mice and digitizers, and then require keyboard entry of the Z value to define the third dimension.

**Figure 3.5****Locating points**

A rectangular prism is created using the 3-D coordinate system by establishing coordinate values for each corner.

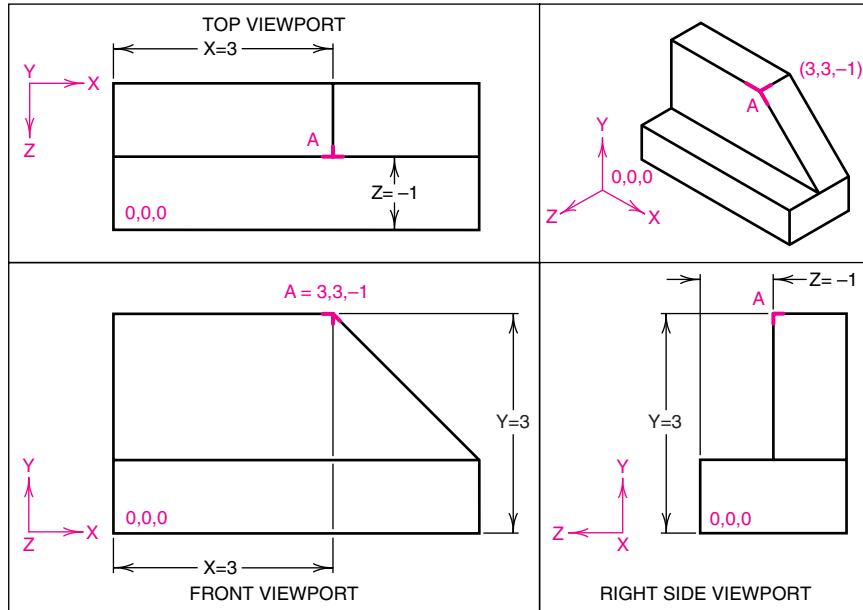
**Practice Exercise 3.1**

Take three sheets of square grid paper and lay out X–Y, Y–Z, and X–Z axes on each one. Label the axes. Using the coordinates given in Figure 3.5, map the points on the grid paper, minus the coordinate not represented. Photocopy all three sheets. Using the photocopy, cut out and glue together the three rectangles defined by the points, in their appropriate orientations. For the missing sides of the solid, make a second photocopy of your sheets, cut them out and glue them in place. They represent exact duplicates of the opposite faces in terms of size and shape. What is different about them? Do the coordinates on the photocopies correctly reflect where the second set of faces is in space?

**3.3.1 Right-Hand Rule**

The **right-hand rule** is used to determine the positive direction of the axes. To visualize the right-hand rule, make a fist with your right hand, with your thumb pointing outward (Figure 3.8A). The direction your thumb is pointing indicates the positive direction on the X axis. Straighten your index finger so that it is pointing straight

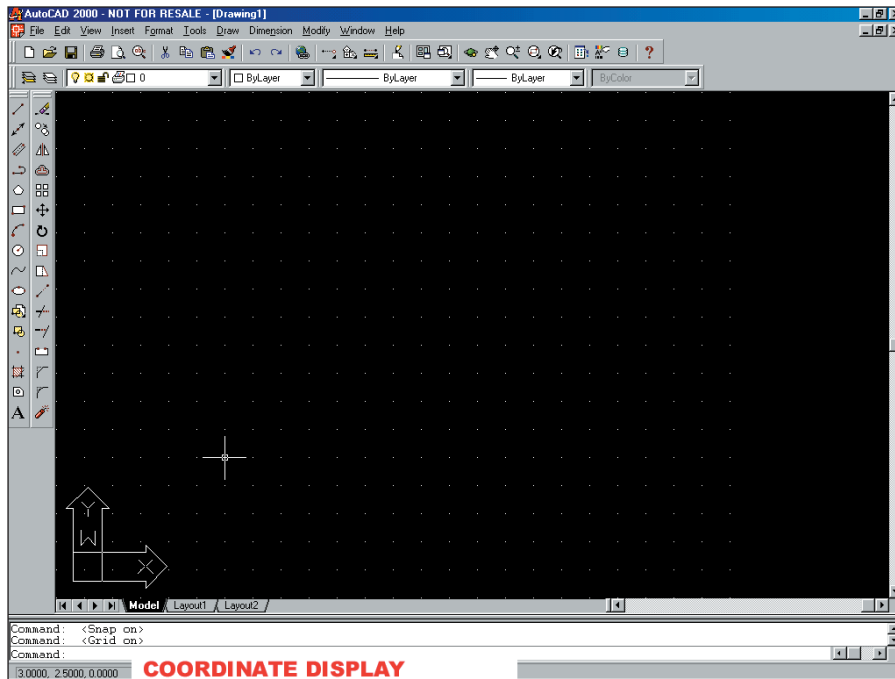




**Figure 3.6**

**Display of coordinate axes in a multiview CAD drawing**

Only two of the three coordinates can be seen in each view.

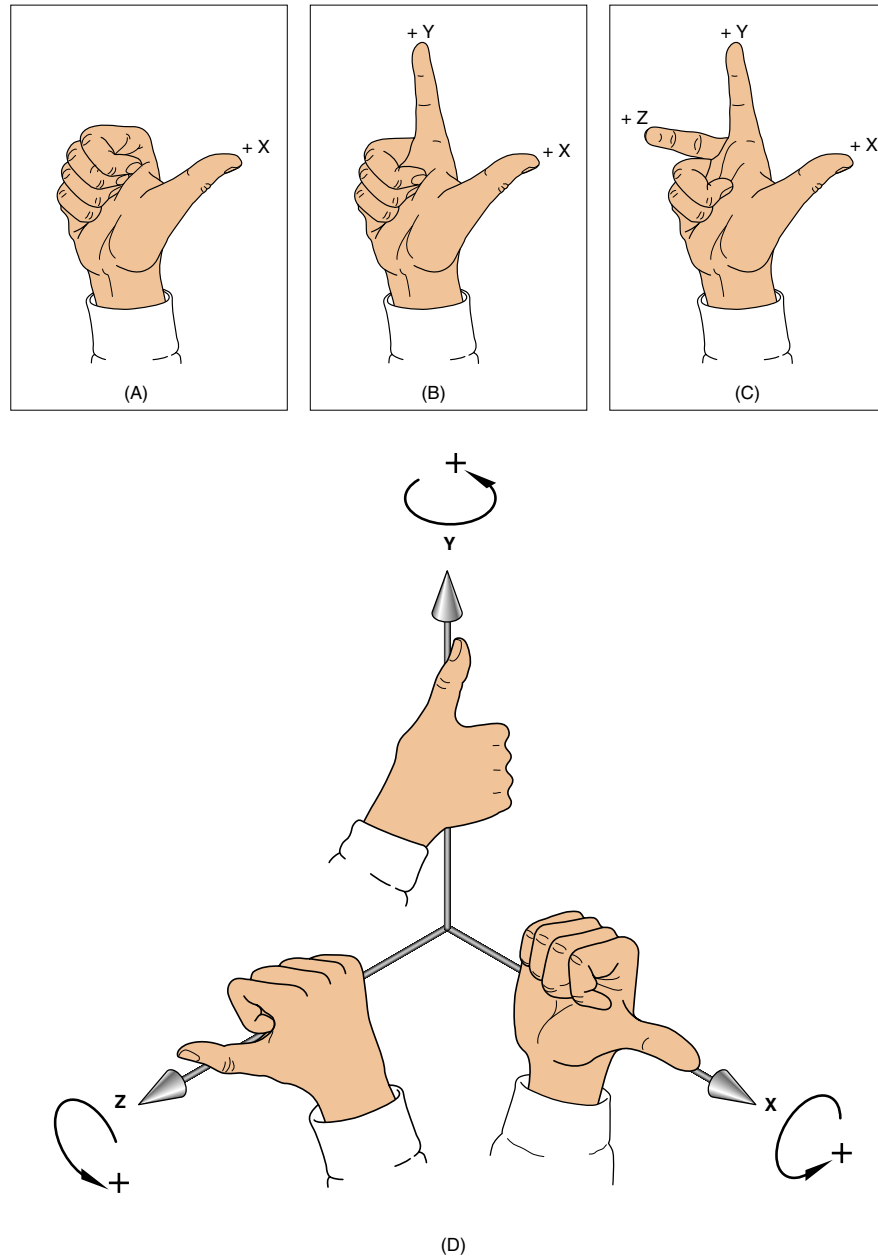


**Figure 3.7**

**Display of coordinate position of cursor on a CAD screen**

The coordinate position of the cursor is located in the bottom left corner of the screen display.

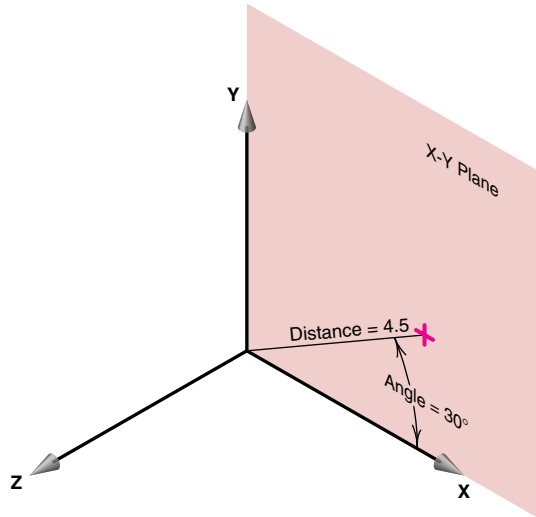
(Courtesy of Gary Bertoline.)

**Figure 3.8****Right-hand rule for axes directions**

The right-hand rule defines the X, Y, and Z axes, as well as the positive and negative directions of rotation on each axis.

up, at 90 degrees to your thumb (Figure 3.8B). The direction your index finger is pointing indicates the positive direction on the Y axis. Straighten your middle finger so that it is pointing forward, at 90 degrees to your index finger (Figure 3.8C). The direction your middle finger is pointing indicates the positive direction of the Z axis.

The right-hand rule is also used to specify the direction of positive rotation about each axis. Imagine that the fingers of your right hand are made into a fist and are wrapped around one of the axes, with the thumb pointing in the positive direction of that axis. The direction that your fingers curl to make the fist identifies the direction of

**Figure 3.9****Polar coordinates**

Polar coordinates use a distance in the X-Y plane and an angle from the X axis to locate a point.

positive rotation for the axis (Figure 3.8D). This technique applies to all three axes.

The right-hand rule is used in both traditional drawing and CAD.

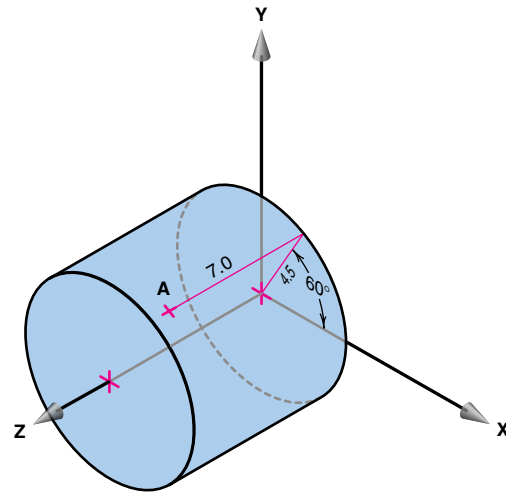
**3.3.2 Polar Coordinates**

**Polar coordinates** are used to locate points in the X-Y plane. Polar coordinates specify a distance and an angle from the origin (0,0). Figure 3.9 shows a line in the X-Y plane, 4.5 units long and at an angle of 30 degrees from the X axis. Polar coordinates are commonly used by CAD systems to locate points.

**3.3.3 Cylindrical Coordinates**

**Cylindrical coordinates** involve one angle and two distances. Cylindrical coordinates specify a distance from the origin, an angle from the X axis in the X-Y plane, and a distance in the Z direction. To illustrate, in Figure 3.10, point A is 7 units in the Z direction, and is 4.5 units from the origin as measured on a line that is at 60 degrees from the X axis in the X-Y plane. Because of the way it is located, point A is on the surface of a cylinder that has a radius of 4.5 units and a length of 7 units; hence the name *cylindrical coordinates*.

Cylindrical coordinates are used in designing circular shapes and in graphic applications. To change cylin-

**Figure 3.10****Cylindrical coordinates**

Cylindrical coordinates locate a point on the surface of a cylinder by specifying a distance and an angle in the X-Y plane, and a distance in the Z direction.

drical coordinates to Cartesian coordinates, use the following equations:

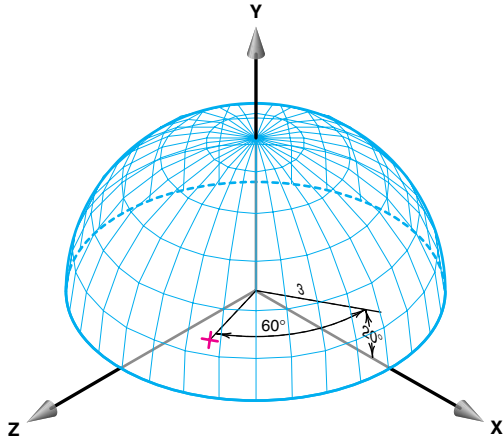
$$\begin{aligned}x &= r \cos \theta \\y &= r \sin \theta \\z &= z\end{aligned}$$

For example, the Cartesian coordinates for point A in Figure 3.10 are 2.25, 4.90, 7, determined as follows: use the equations shown above and substitute the values  $r = 4.5$  and angle  $\theta = 60$  degrees:

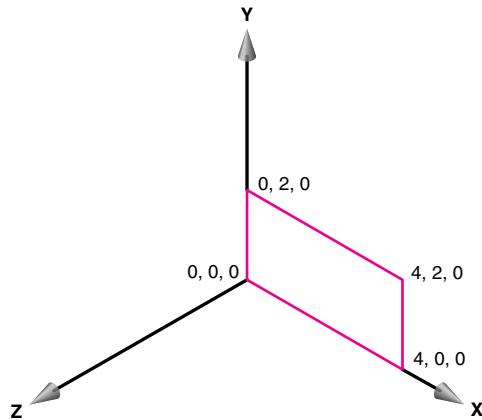
$$\begin{aligned}x &= 4.5 \cos 60 = 2.25 \\y &= 4.5 \sin 60 = 3.90 \\z &= 7\end{aligned}$$

**3.3.4 Spherical Coordinates**

**Spherical coordinates** are used to locate points on a spherical surface by specifying two angles and one distance (Figure 3.11). Spherical coordinates specify a distance from the origin on a line that is at an angle from the X axis in the X-Y plane, and then an angle away from the X-Y plane. In Figure 3.11, the distance in the X-Y plane is 3 (which defines the radius of the sphere), the angle in the X-Y plane is 20 degrees, locating a point from which an angle of 60 degrees is drawn away from the X-Y plane along the surface of the sphere.

**Figure 3.11****Spherical coordinates**

Spherical coordinates locate a point on the surface of a sphere by specifying an angle in one plane, an angle in another plane, and one length.

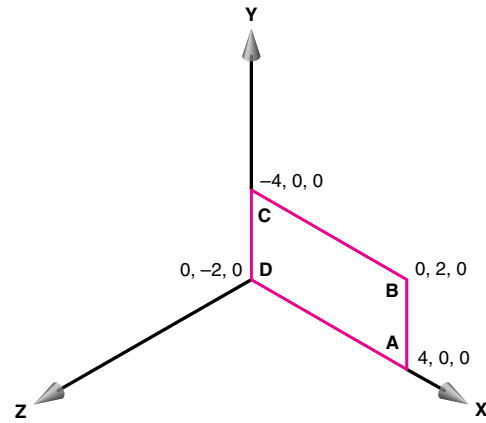
**Figure 3.12****Absolute coordinates**

Absolute coordinate values are referenced to the fixed origin.

**3.3.5 Absolute and Relative Coordinates**

**Absolute coordinates** are always referenced to the origin (0,0,0). In Figure 3.12, the rectangle is defined by corners that have absolute coordinate values of:

0,0,0  
4,0,0  
4,2,0  
0,2,0

**Figure 3.13****Relative coordinates**

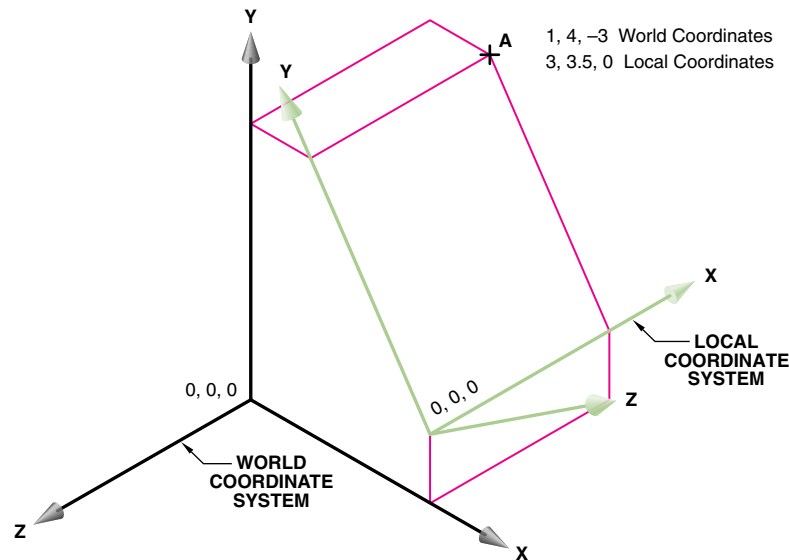
Relative coordinate values are referenced to the previous specified point.

**Relative coordinates** are always referenced to a previously defined location and are sometimes referred to as *delta coordinates*, meaning changed coordinates. Figure 3.13 shows the same rectangle as in Figure 3.12, but constructed using relative coordinates starting with point A, then locating points B, C, and D. Point A has values 4,0,0; B is referenced from A and has relative values 0,2,0; C is referenced from B and has relative values -4,0,0; and D is referenced from C and has relative values 0,-2,0.

**Practice Exercise 3.2**

Using the coordinates given in the text, build a wireframe model out of wire. Create three coordinate planes (X-Y, Y-Z, and X-Z) on square grid paper. Glue them onto a cardboard backing and tape them together to form a grid box with the grid facing inward. Place the wireframe in the box so that the corners correspond to the correct absolute coordinates. Count off the number of grids to get from one corner of the object to another. Use a corner other than 0,0,0 as a reference point and move the wireframe model to a different location in the grid box. Do the absolute coordinates of the corners change? Count the number of grids from one corner to another. Do the delta coordinates change?

Do the same exercise with 3-D models on the computer. Use either coordinate readouts in the status area, or 3-D grid planes to help visualize the results.



**Figure 3.14**

### World and local coordinates

This object in 3-D coordinate space shows the difference between the world coordinate system and a local coordinate system. World and local coordinate systems are commonly used with CAD to construct 3-D objects. Point A has different coordinate values, depending on whether the local or world coordinate system is used.

### 3.3.6 World and Local Coordinate Systems

CAD systems normally use two types of coordinate systems: world, and user or local systems. Both of these are based on Cartesian coordinates. **The world coordinate system** is the stationary or reference system where the geometry is defined and stored. The world coordinate system uses a set of three numbers (x,y,z) located on three mutually perpendicular axes and measured from the origin (0,0,0) (Figure 3.14). The **local coordinate system** is a moving system that can be positioned anywhere in 3-D space by the user, to assist in the construction of geometry. In Figure 3.14, axes X and Y of the local coordinate system are aligned with the inclined plane, resulting in local coordinate values that are different from the world coordinate values. Locating a point on the inclined surface will be easier using the local coordinate system because the X–Y plane of the local coordinate system is parallel to the inclined surface. For example, the point A has world coordinates of 1,4,-3 and local coordinates of 3,3.5,0.

### Practice Exercise 3.3

Create a workplane of either stiffened grid paper or clear plastic, with two axes on it. The third axis can be represented sticking out of the plane, if desired. Place the plane on various surfaces of objects (including inclined and oblique surfaces). Calculate the local coordinate locations of various features on the object. Compare them to the world coordinates of the features, using the grid box from the previous exercise as the world coordinate reference.

Do the same exercise using 3-D models on a computer. Use locally defined workplanes, and compare the local coordinate readouts to world coordinate values. The exercise can be done with 2-D CAD systems and locally (user) defined coordinate systems.

## 3.4 Geometric Elements

Different systems can be used to categorize geometric elements. In this text, geometric elements are categorized as points, lines, surfaces, or solids. Lines, surfaces, and



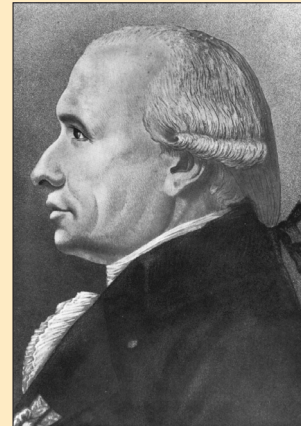
## Historical Highlight

### Gaspard Monge

Gaspard Monge, the man known as “the father of descriptive geometry,” was an incredibly talented man. He was a mathematician, a scientist, and an educator working in physics, chemistry, analytical geometry, and, of course, descriptive geometry.

Monge was born the son of a poor merchant in eighteenth century France. His father managed to help him get a sufficient education and Monge’s talent took him the rest of the way. More specifically, while he was a student at Mezeres, his unique solution to a problem involving a fortress design got him promoted from assistant to a full professor. A couple years later he was made a professor of mathematics and later took over the physics department.

Unfortunately, Monge was not permitted to make his unique solution publicly known; it was deemed a military secret. He continued to work on the principles he had used, and expanded and revised them so that they could be used to help solve any technical graphics problem. Then, in 1794, Monge helped to found the first modern engineering school, Ecole Polytechnique, and was finally able to teach the principles of descriptive geometry. It was during the next year that he published his book *Geometrie Descriptive*. His work would change technical drawings from what were simple pictures into actual plans or engineering drawings.



Source: © Corbis.

Monge received many awards and honors in his lifetime, but they were all taken away when Louis XVIII came to power. Monge had been very loyal to Napoléon Bonaparte, and when Napoléon lost power Monge’s career was ruined. He died in disgrace in 1818. There is a positive note, however. Even after his death, Monge still had students and followers who continued his work, overseeing further editions of *Geometrie Descriptive*.

solids also have many subcategories. Figure 3.15 lists each category and many of the geometric elements in each category. The remainder of this chapter will define, illustrate, construct, and apply many of the geometric elements listed in Figure 3.15.

## 3.5 Points, Lines, Circles, and Arcs

Points, lines, circles, and arcs are the basic 2-D geometric primitives, or generators, from which other, more complex geometric forms can be derived or mathematically produced. For example, by taking a straight line and moving it in a certain way through a circular path, you can create a cylinder. This section defines, illustrates, and describes how to create points, lines, circles, and arcs.

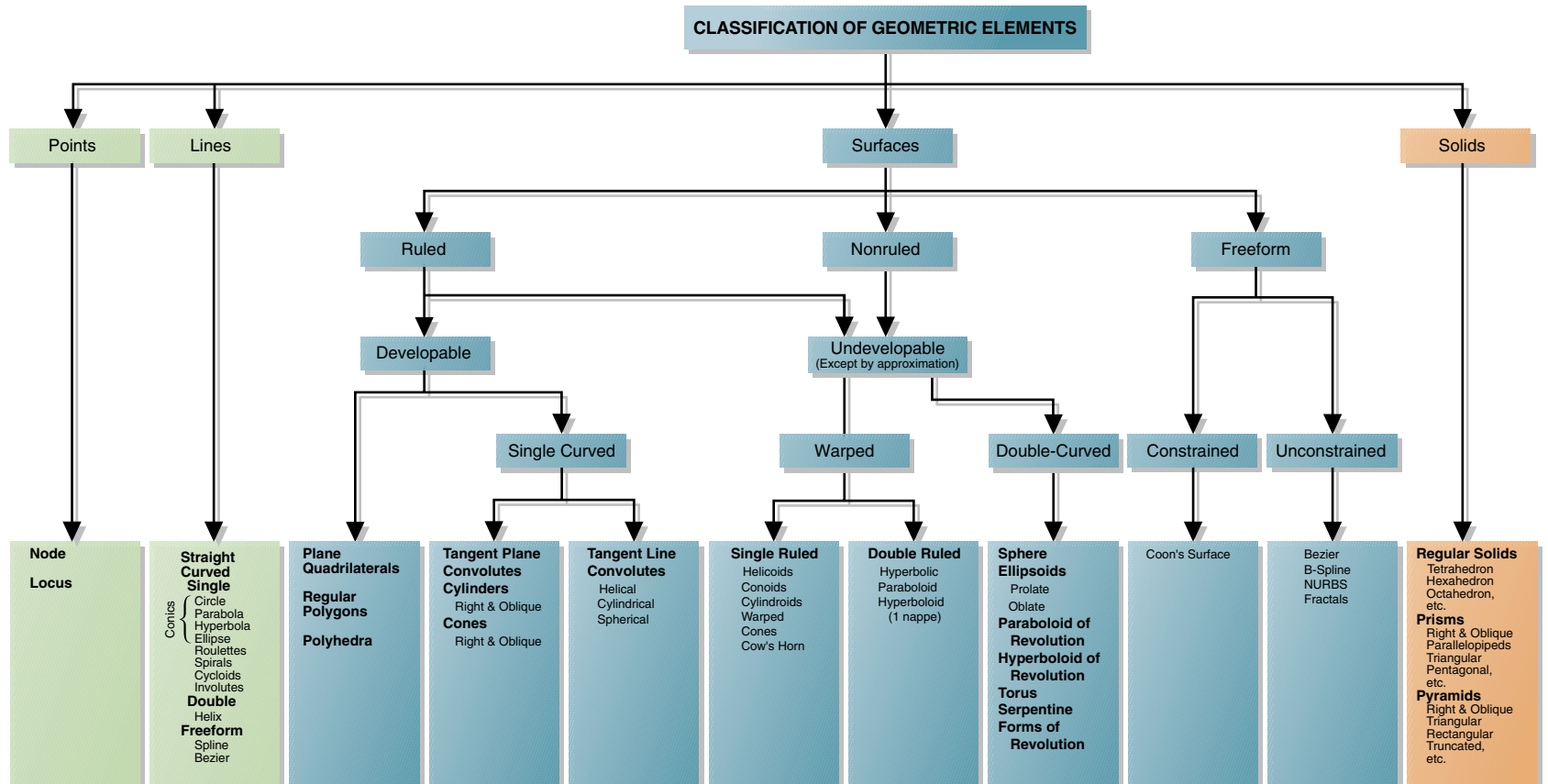
### 3.5.1 Points

A **point** is a theoretical location that has neither width, height, nor depth. Points describe an exact location in space. Normally, a point is represented in technical draw-

ings as a small cross made of dashes that are approximately  $\frac{1}{8}$ ” long (Figure 3.16A and D). With CAD, it is possible to extrude (i.e., string out) a point to create a line, or to extrude several points to create more complicated forms (Figure 3.16B). A point is found at the intersection of two lines or at the end of a finite line. In computer graphics, it is common to use the word **node** to mean a point (Figures 3.16C, E, F, and G). For example, the intersection of geometric entities, and specific locations along arcs, circles, and splines, are called nodes.

Analysis of a problem may indicate that a certain unknown point must be located at a fixed distance from some given point, line, or arc. The location of this unknown point is called a locus. A **locus** represents all possible positions of a point. The locus of a point may be drawn as a line, circle, or arc. For example, the center of each circle shown in Figure 3.16H forms a locus of centers.

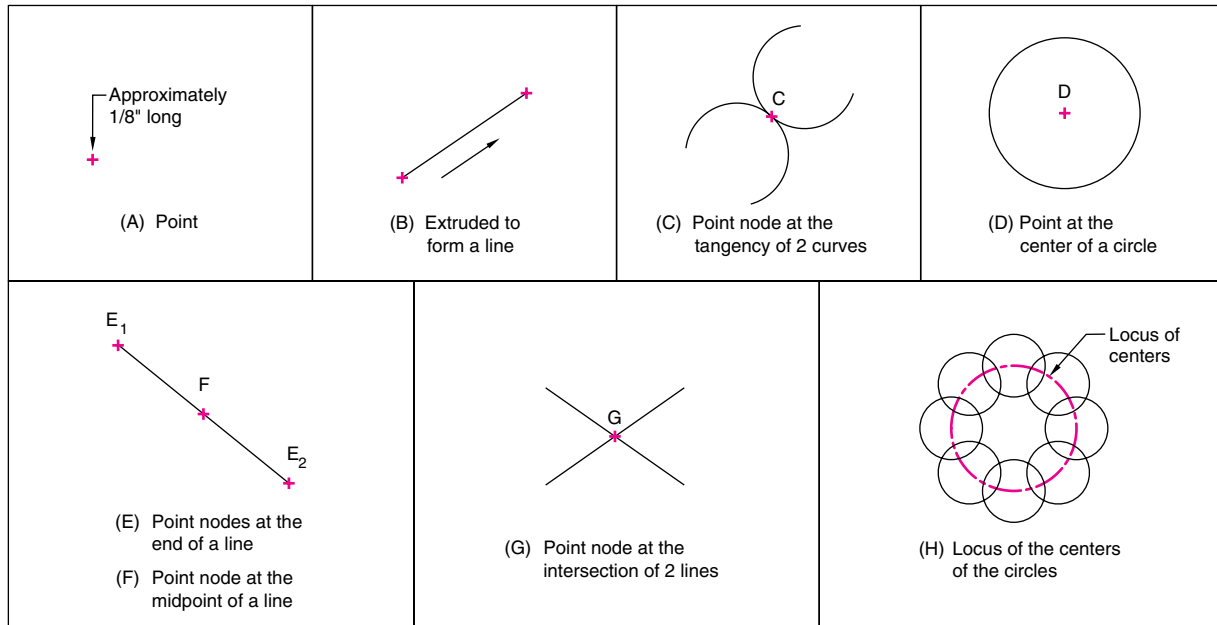
Nodes are very important when constructing geometric forms with CAD. CAD systems normally allow the user to locate exactly such important geometric elements as endpoints, centers, and intersections. These nodes can be used to construct geometric forms more accurately. For



**Figure 3.15**

### Classification of geometric elements

Geometric elements are divided into four main categories: points, lines, surfaces, and solids. Each category contains subcategories in which most geometric elements are found.

**Figure 3.16****Examples and representation of points**

A point is used to mark the locations of centers and loci, and the intersections, ends, and midpoints of entities.

example, a line can be accurately drawn from the midpoint of an existing line, because the CAD system stores the exact location as a node.

**3.5.2 Lines**

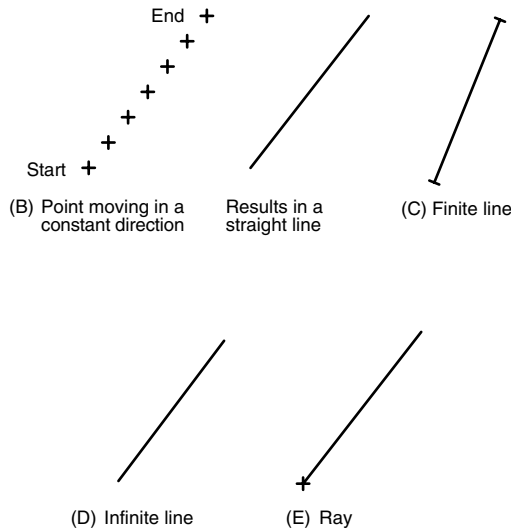
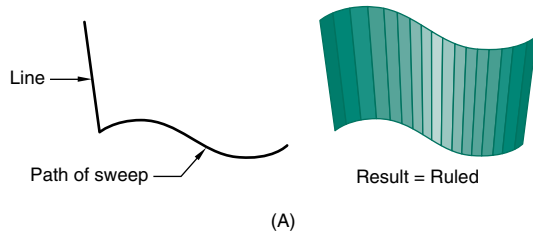
A **line** is a geometric primitive that has length and direction, but not thickness. A line may be straight, curved, or a combination of these. As with points, it is possible to create more complex geometric forms from lines by using CAD extrusion or sweeping operations, as shown in Figure 3.17A. Lines also have important relationships or *conditions*, such as parallel, intersecting, and tangent.

**Straight Lines** A straight line is generated by a point moving in a constant direction (Figure 3.17B). Straight lines can be either finite or infinite in length. A straight finite line is a line of *specific* length (Figure 3.17C). A straight infinite line is a line of *nonspecific* length (Figure 3.17D).

A *ray* is a straight infinite line that extends into infinity from a specified point (Figure 3.17E). Ray is a common term used in computer graphics to describe the path of a light ray, and is important when a scene is being rendered.

The relationship of one line to another results in a condition, such as parallel or perpendicular. A **parallel line** condition occurs when two or more lines on a plane are a constant distance apart (Figure 3.18A). A **nonparallel** line condition occurs when two or more lines on one or more planes are spaced unevenly apart (Figure 3.18B). A **perpendicular line** condition, sometimes called a *normal*, occurs when two or more lines on a plane intersect each other at right angles (90 degrees) (Figure 3.18C). An **intersecting line** condition occurs when two or more lines cross each other at a common point (Figure 3.18D). A **tangent** condition exists when a straight line is in contact with a curve at a single point (Figure 3.18E).

In technical drawing, lines are used to represent the intersections of nonparallel planes, and the intersections are called *edges* (Figure 3.18F).



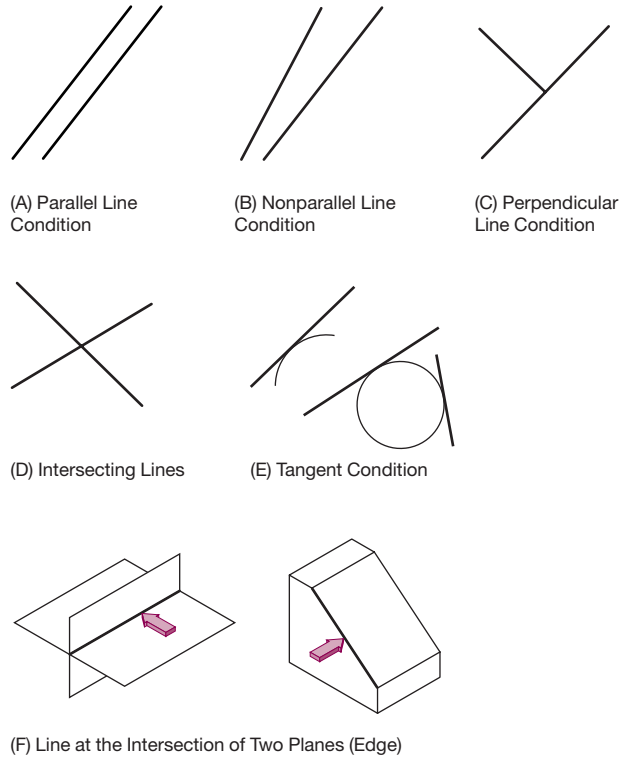
**Figure 3.17**  
Examples and representation of lines

Lines can be used to construct other geometric forms, such as a ruled surface. Lines are either finite or infinite, and are called rays in computer graphics.

**Practice Exercise 3.4**

Create a line in 3-D space, either with a wire or on a computer. Hold the line fixed along any primary axis and view it from the directions of the three primary axes. In which views does it look like a line? In which views does it look its full length? In which views does it look like a point? Move the line so that it does not align with any of the primary axes. Repeat the viewing/analyzing process and make multiview sketches of the line.

**Curved Lines** A **curved line** is the path generated by a point moving in a constantly changing direction, or is the



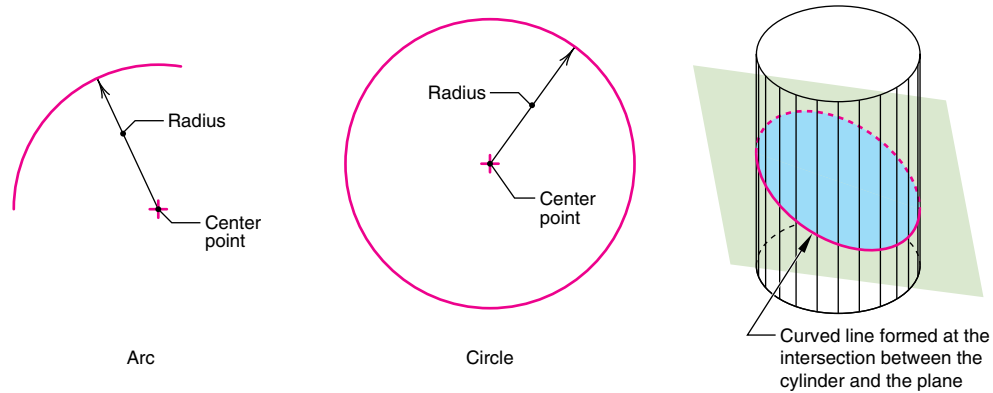
**Figure 3.18**  
Line relationships

The relationship of one line to another results in a condition.

line of intersection between a 3-D curved surface and a plane (Figure 3.19). Curved lines are classed as single-curved or double-curved. On a **single-curved line**, all points of the line are in a plane. Examples of single-curved lines are a circle, ellipse, parabola, hyperbola, spiral, spline, involute, and cycloid. On a **double-curved line**, no four consecutive points are in the same plane. Examples of double-curved lines are the cylindrical helix, the conical helix, and the general form created at the line of intersection between two curved surfaces.

**Practice Exercise 3.5**

Create a single-curved line in 3-D space, either with a wire or on a computer. Align the line along a primary axis and view it along the three primary axes. In which views does it look like a straight line? a curved line? In which views does it look its full length? Move the line so that it does not align

**Figure 3.19****Curved lines**

Regular curves are bent lines of constant radius. Regular curves include arcs, circles, and curved lines of intersection on cylinders.

with any of the primary axes. Repeat the viewing/analyzing process. Can you lay a plane up against the curved line? Try it.

Repeat the above exercise with a double-curved line.

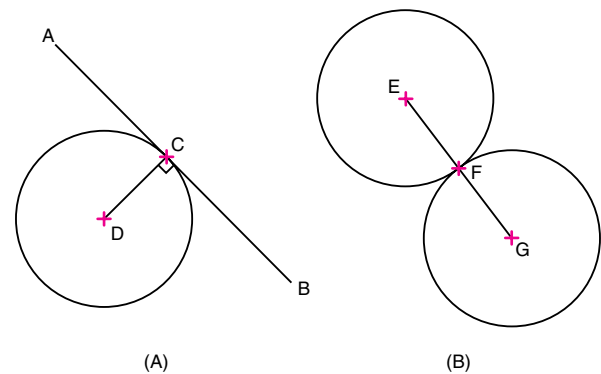
A **regular curve** is a constant-radius arc or circle generated around a single center point. The line of intersection between a circular cylinder or sphere and a plane perpendicular to the axis is also a regular curve.

**Irregular curves**, such as parabolas, hyperbolas, and splines, are defined and methods for their construction are described later in this chapter.

**3.5.3 Tangencies**

In planar geometry, a tangent condition exists when a straight line is in contact with a curve at a single point; that is, *a line is tangent to a circle if it touches the circle at one and only one point*. At the exact point of tangency, a radius makes a right angle to the tangent line. In Figure 3.20A, the tangent point between the line and the circle is point C.

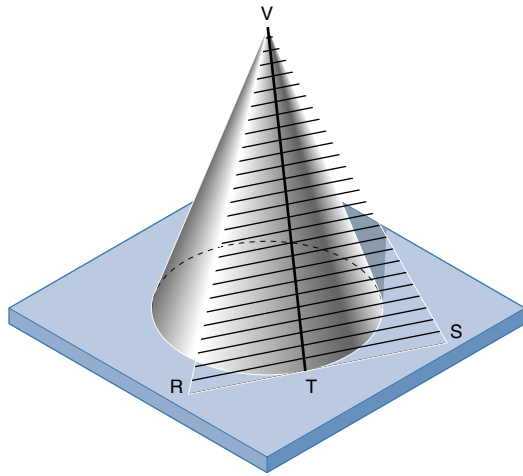
*Two curves are tangent to each other if they touch in one and only one place*. When two arcs or circles are tangent, a line drawn to connect the centers of the two arcs or circles locates the point of tangency. In Figure 3.20B, the tangent point between the two circles is located at point F.

**Figure 3.20****Planar tangents**

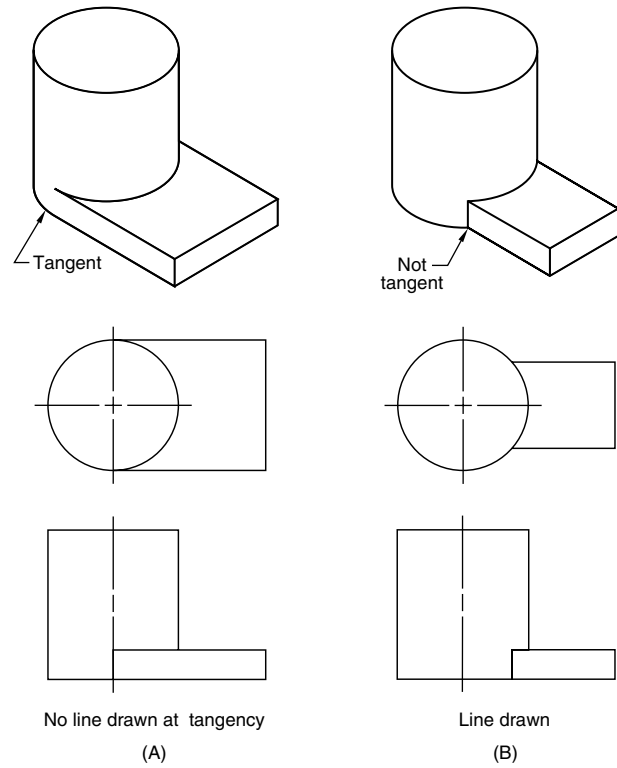
Planar tangent conditions exist when two geometric forms meet at a single point and do not intersect.

In 3-D geometry, a tangent condition exists when a plane touches but does not intersect another surface at one or more consecutive points (Figure 3.21). Another tangent condition exists where there is a smooth transition between two geometric entities (Figure 3.22A). However, a corner between two geometric entities indicates a non-tangent condition (Figure 3.22B). A line is tangent to a surface if the line touches the surface at a single point (Figure 3.23).

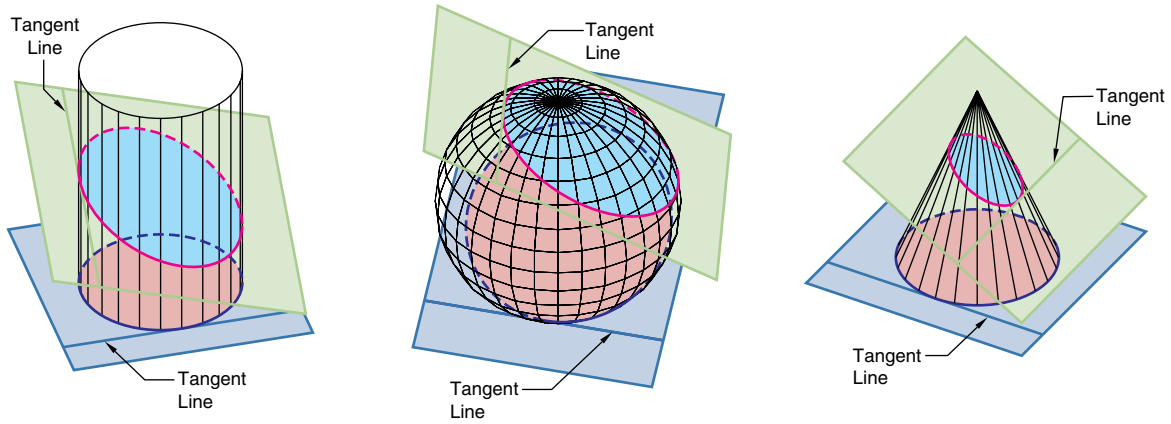




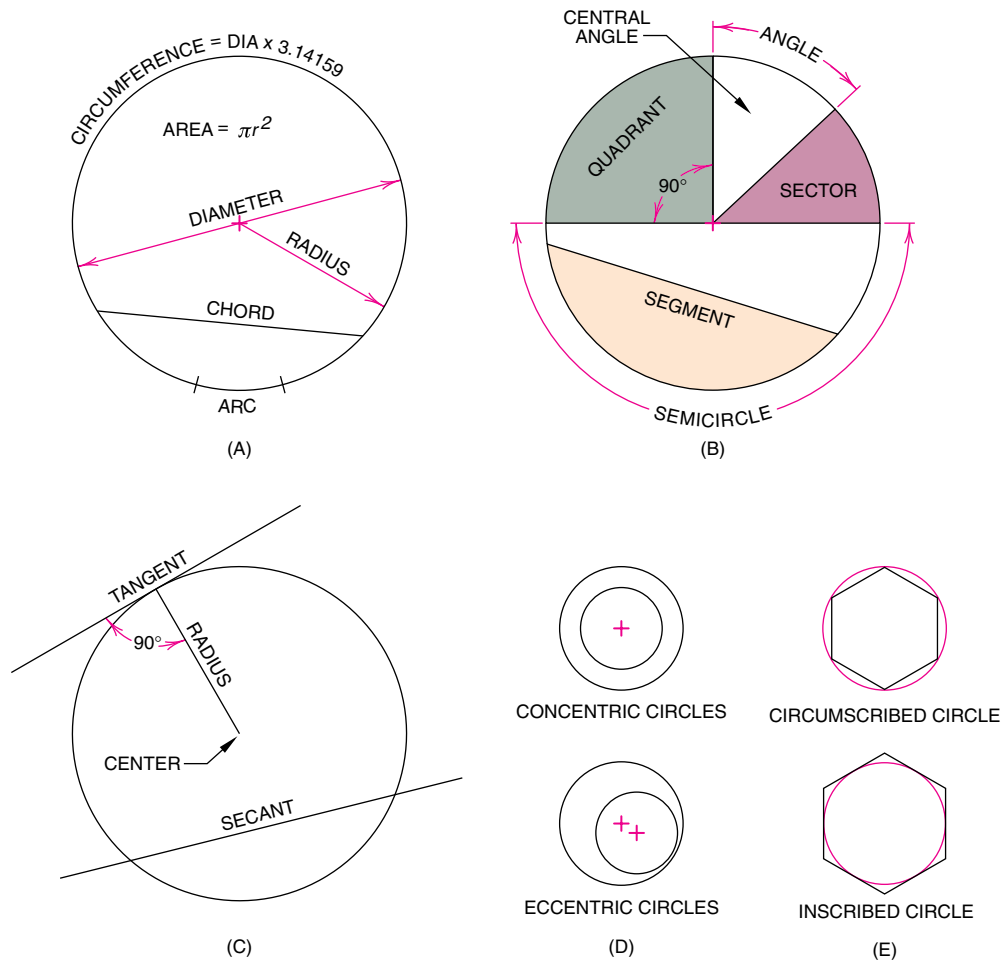
**Figure 3.21**  
**Tangent plane**  
 Plane RVS is tangent to the cone at line VT.



**Figure 3.22**  
 Tangent and nontangent conditions in 3-D geometry



**Figure 3.23**  
**Tangent lines**  
 The lines of intersection between each plane and each solid are tangent conditions, as are lines that touch a surface at a single point.

**Figure 3.24****Circle definitions**

A circle is a single-curved plane with all points at an equal distance from a point called the center. The important features of a circle are shown.

**Practice Exercise 3.6**

Using physical models of spheres, cylinders, cones, and planes, create points/lines of tangencies.

Using 2-D and 3-D computer models, use transformation commands (MOVE, ROTATE, and OBJECT SNAP) to position objects so that they make contact. Will all conditions of two objects touching at a single point/line result in a tangency? What if there is overlap and they touch at more than one point/line? Use 2-D/3-D Boolean intersect commands to evaluate both tangent and nontangent relationships.

Tangent construction is an important part of technical drawing. With traditional tools, tangencies are constructed

using triangles and a compass. With CAD, tangent construction is performed automatically, using TANGENT point snap commands.

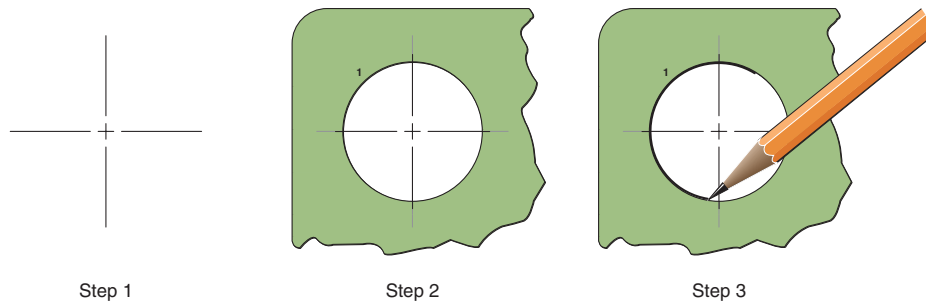
**3.5.4 Circles**

A **circle** is a single-curved-surface primitive, all points of which are equidistant from one point, the center. A circle is also created when a plane passes through a right circular cone or cylinder and is perpendicular to the axis of the cone.

The elements of a circle are as follows (Figure 3.24):

Center. The midpoint of the circle.

Circumference. The distance all the way around the circle.

**Figure 3.25****Constructing a circle using a template**

A circle template can be used instead of a compass to draw circles. The template comes in a series of standard sizes. To construct a circle using a template, align the marks on the template with the center lines for the circle.

**Radius.** A line joining the center to any point on the circumference.

**Chord.** A straight line joining any two points on the circumference.

**Diameter.** A chord that passes through the center. The diameter is equal to twice the radius.

**Secant.** A straight line that goes through a circle but not through the center.

**Arc.** A continuous segment of the circle.

**Semicircle.** An arc measuring one-half the circumference of the circle.

**Minor arc.** An arc that is less than a semicircle.

**Major arc.** An arc that is greater than a semicircle.

**Central angle.** An angle formed by two radii.

**Sector.** An area bounded by two radii and an arc, usually a minor arc.

**Quadrant.** A sector equal to one-fourth the area of the circle. The radii bounding a quadrant are at right angles to each other.

**Segment.** An area bounded by a chord and a minor arc. The chord does not go through the center.

**Tangent.** A line that touches the circle at one and only one point.

**Concentric circles.** Circles of unequal radii that have the same center point.

**Eccentric circles.** Circles of unequal radii that have different centers, and one circle is inside the other.

**Circumscribed circle.** A circle drawn outside of a polygon such that each vertex of the polygon is a point on the circle.

**Inscribed circle.** A circle drawn inside a polygon such that all sides of the polygon are tangent to the circle.

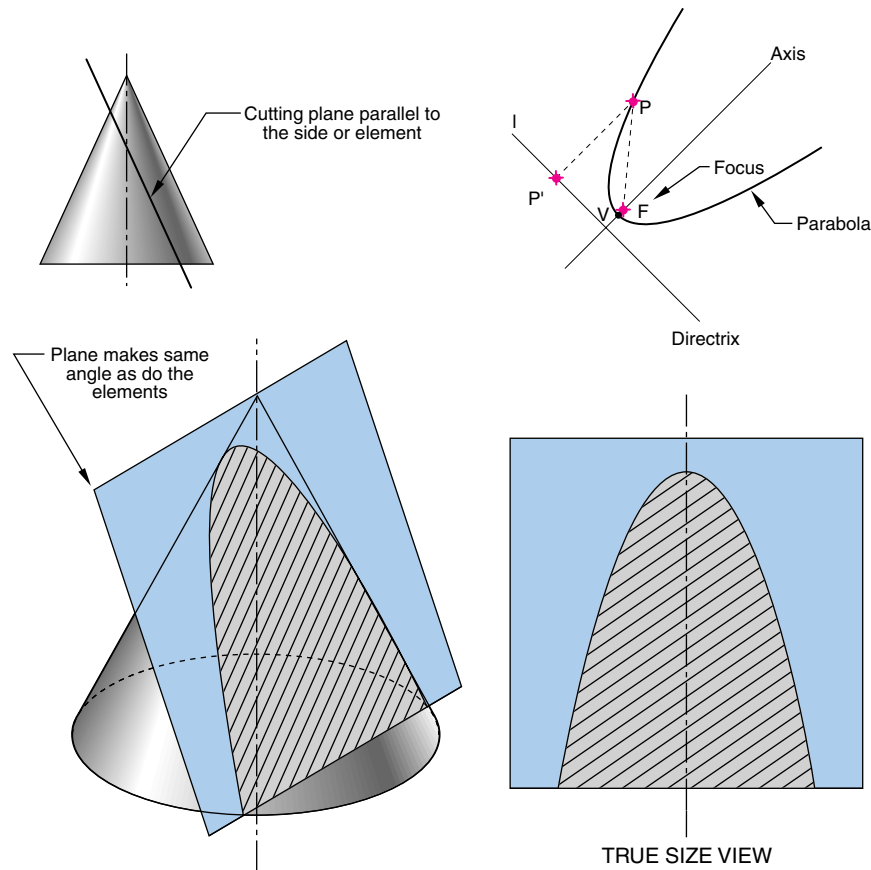
To construct a circle using a compass, refer to Chapter 1.

**Drawing a Circle Using a Template** Templates are often used to construct circles for technical drawings. The template is made of plastic with multiple holes of various diameters. Each hole is of a specific diameter that is marked on the template, along with guidelines to align the hole with the center lines for the circle to be drawn (Figure 3.25).

## 3.6 Conic Curves

Conic curves, or conics, are special-case single-curved lines that can be described in several ways: as sections of a cone; as algebraic equations; and as the loci of points. For our purposes, **conics** are the curves formed by the intersection of a plane with a right circular cone, and they include the ellipse, parabola, and hyperbola. (The circle is a special case ellipse.) A right circular cone is a cone that has a circular base and an axis that passes at 90 degrees through the center of the circular base.

Conics are often used in engineering design and in science to describe physical phenomena. No other curves have as many useful properties and practical applications.



**Figure 3.26**

### Parabola

A parabolic curve is created by passing a plane through a cone, with the plane parallel to the side (elements) of the cone. A parabolic curve is defined mathematically as a set of points that are equidistant from a focus point and a directrix.

### 3.6.1 Parabolas

A **parabola** is the curve created when a plane intersects a right circular cone parallel to the side (elements) of the cone (Figure 3.26). A parabola is a single-curved-surface primitive. Mathematically, a parabola is defined as the set of points in a plane that are equidistant from a given fixed point, called a *focus*, and a fixed line, called a *directrix*. (Figure 3.26)

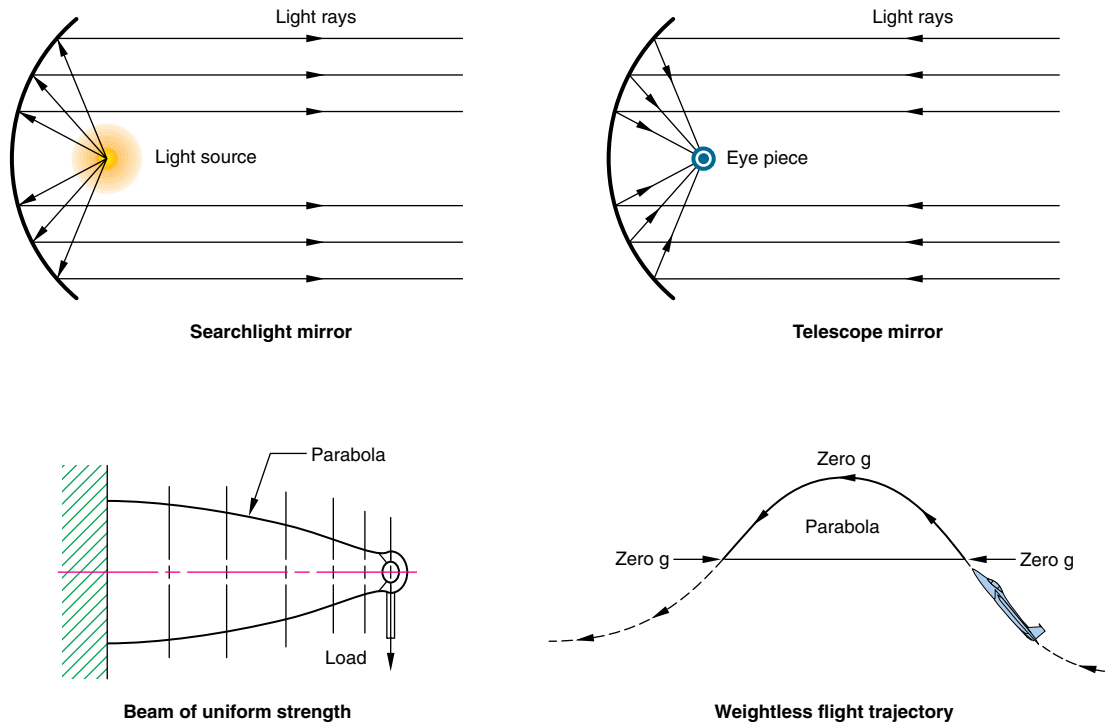
**Engineering Applications of Parabolas** Parabolas have a unique reflective property, as shown in Figure 3.27. Rays originating at a parabola's **focus** are reflected out of the parabola parallel to the axis, and rays coming into the parabola parallel to the axis are reflected to the focus. Parabolas are used in the design of mirrors for telescopes, reflective mirrors for lights, such as

automobile headlights, cams for uniform acceleration, weightless flight trajectories, antennae for radar systems, arches for bridges, and field microphones commonly seen on the sidelines of football games.

A parabola revolved about its axis generates a 3-D ruled surface called a **paraboloid**. An auditorium ceiling in the shape of a paraboloid reduces reverberations if the speaker is standing near the focus.

### 3.6.2 Hyperbolas

A **hyperbola** is the curve of intersection created when a plane intersects a right circular cone and makes a smaller angle with the axis than do the elements (Figure 3.28). A

**Figure 3.27****Engineering applications for a parabola**

Common applications include mirrors for lights and telescopes and for structural beams.

hyperbola is a single-curved-surface primitive. Mathematically, a hyperbola is defined as the set of points in a plane whose distances from two fixed points, called the *foci*, in the plane have a constant difference (Figure 3.29).

**Engineering and Science Applications of Hyperbolas** Hyperbolic paths form the basis for the Long Range Navigation (LORAN) radio navigation system. Hyperbolas are also important in physics, as Einstein discovered in his theory of relativity. Ernest Rutherford discovered that when alpha particles are shot toward the nucleus of an atom, they are repulsed away from the nucleus along hyperbolic paths. In astronomy, a comet that does not return to the sun follows a hyperbolic path.

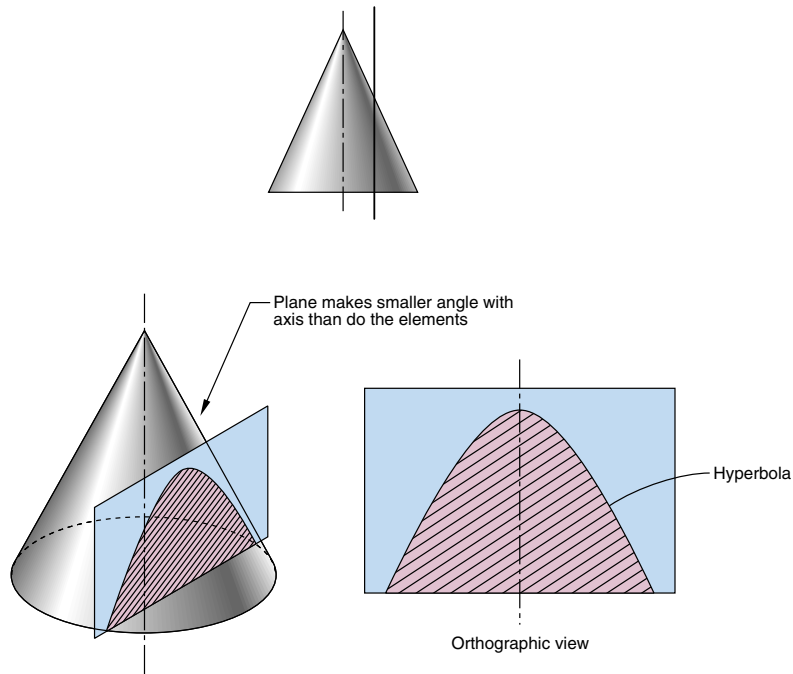
Reflecting telescopes use elliptical, hyperbolic, and paraboloid mirrors, as shown in Figure 3.30. Light from a celestial body reflects off a primary parabolic mirror at the base of the telescope and heads to the focus of the parabola. A hyperbolic mirror is positioned such that the focus of the parabola and one focus of the hyperbola are in the same plane. The light reflecting from the parabolic mirror reflects off the hyperbolic mirror and goes

through the second focus of the hyperbola. This focus is shared with the focus of a partial elliptical mirror. The light is then reflected through the other focus of the ellipse, which is where the eyepiece of the telescope is located.

**3.6.3 Ellipses**

An **ellipse** is a single-curved-surface primitive and is created when a plane passes through a right circular cone at an angle to the axis that is greater than the angle between the axis and the sides (Figure 3.31). Also, a circle, when viewed at an angle, appears as an ellipse (Figure 3.32). Mathematically, an ellipse is the set of all points in a plane for which the sum of the distances from two fixed points (the foci) in the plane is constant (Figure 3.33). The **major diameter** (major axis) of an ellipse is the longest straight-line distance between the sides and is through both foci. The **minor diameter** (minor axis) is the shortest straight-line distance between the sides and is through the bisector of the major axis. The foci are the two points used to construct the perimeter and are on the major axis.

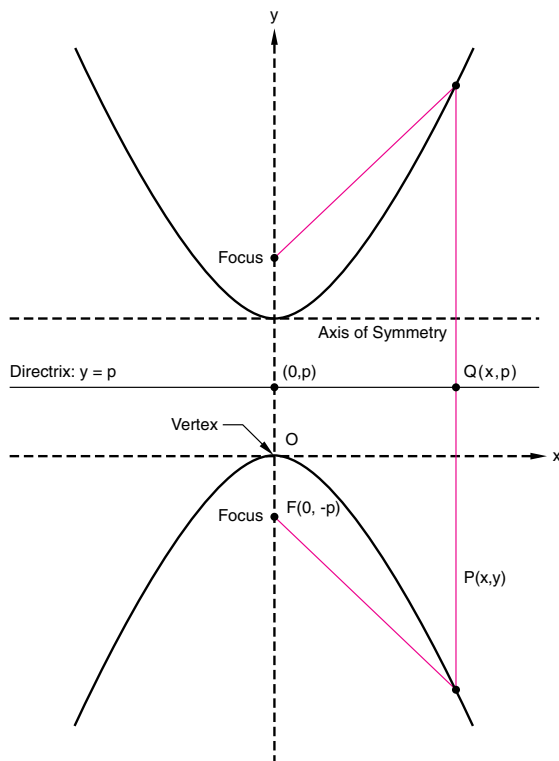




**Figure 3.28**

### Hyperbola

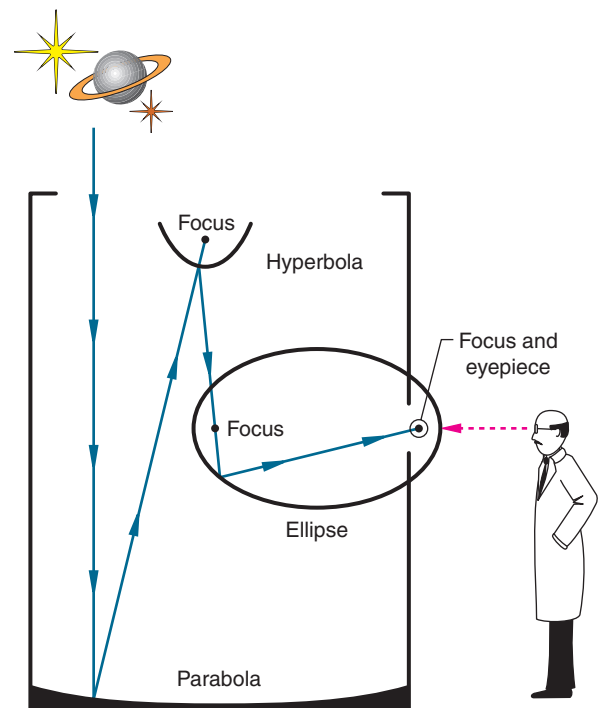
A hyperbola is created by passing a plane through a cone at a smaller angle with the axis than that made by the elements.



**Figure 3.29**

### Mathematical definition of a hyperbola

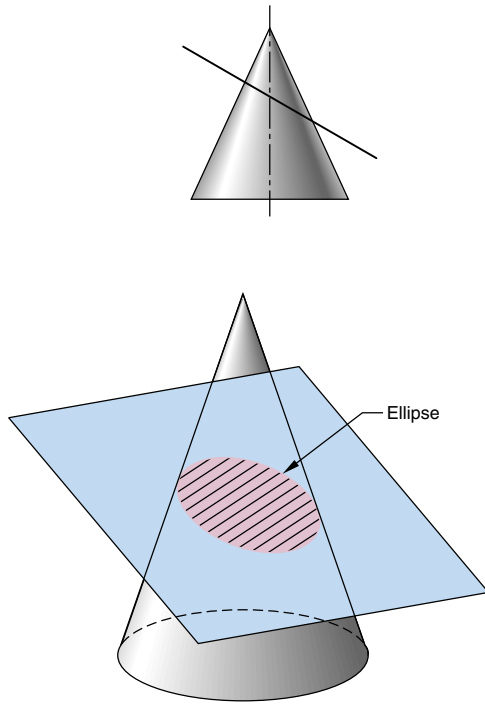
The set of points in a plane whose distances from two fixed points, called the foci, in the plane have a common difference.



**Figure 3.30**

### Telescope

Schematic representation of a telescope that uses hyperbolic, parabolic, and elliptical mirrors.

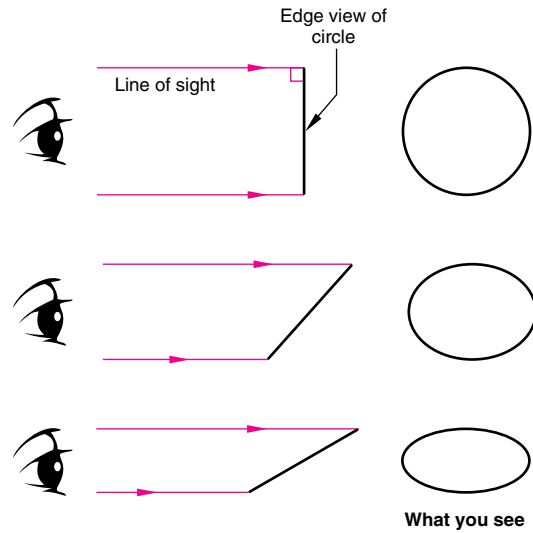


**Figure 3.31**

**Ellipse**

An ellipse is formed by the line of intersection between an inclined plane and a cone.

Ellipse templates come in intervals of 5 degrees, such as 20, 25, and 30. The viewing angle relative to the circle determines the ellipse template to be used. (Figure 3.34) Each ellipse has a set of center lines marked on the plastic to align with the major and minor diameters drawn on the paper.



**Figure 3.32**

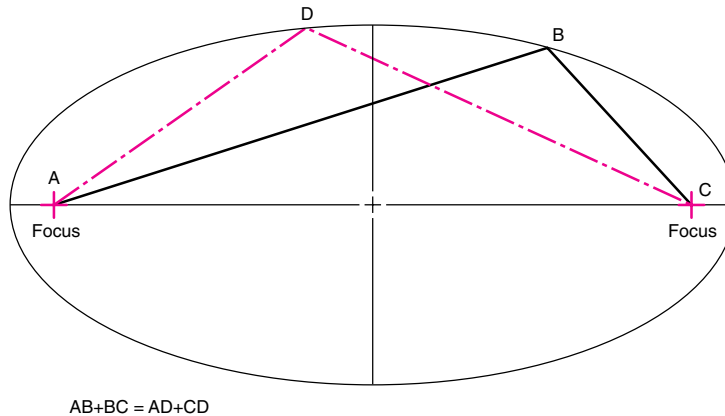
**Line of sight to create ellipses**

A line of sight other than 90 degrees changes the appearance of a circle to an ellipse.

**Constructing an Ellipse Using a Template**

**Step 1.** To draw an ellipse using a template, draw the major and minor diameters for the ellipse (Figure 3.35). Determine the angle and find the applicable ellipse template. Determine which ellipse on the template most closely matches the major and minor diameters.

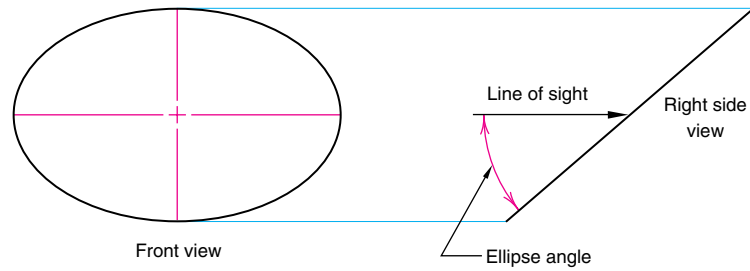
**Step 2.** Line the template ellipse marks along the major and minor diameters and draw the ellipse, using the template as a guide.



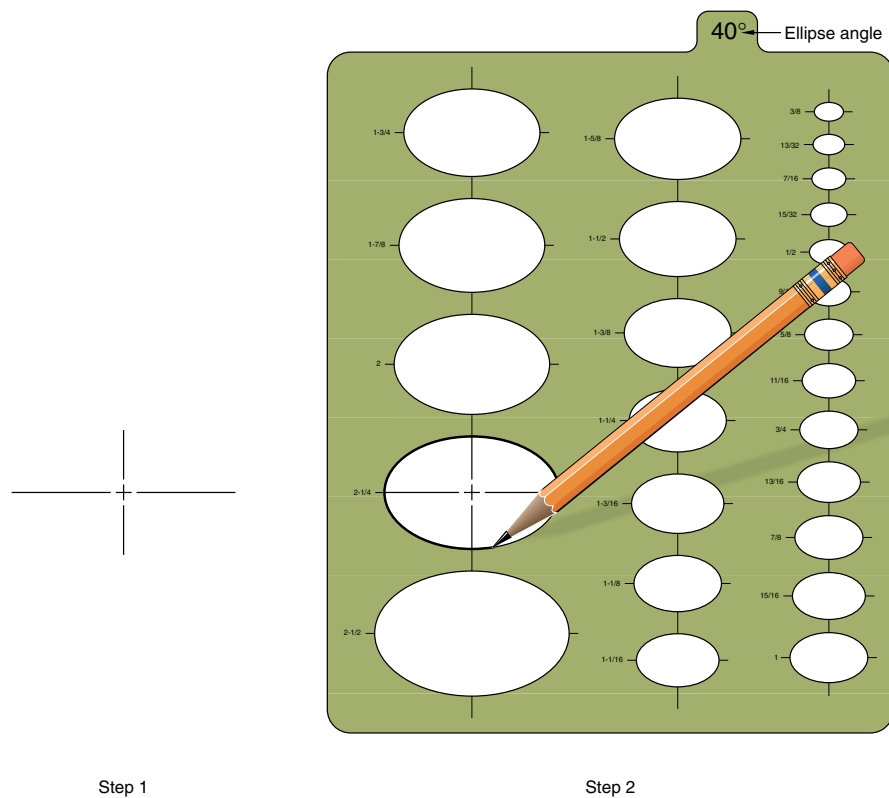
**Figure 3.33**

**Mathematical definition of an ellipse**

An ellipse is mathematically defined as the set of points for which the sum of the distances to two focus points is constant.

**Figure 3.34****Viewing angle determines ellipse angle**

The viewing angle relative to the circle determines the ellipse template to be used. The circle is seen as an inclined edge in the right side view and foreshortened (as an ellipse) in the front view. The major diameter is equal to the diameter of the circle.

**Figure 3.35****Drawing an ellipse using a template**

A CAD system will automatically create an ellipse once the major and minor diameters are specified and the location of the center point (the intersection of the major and minor diameters) is picked. Most CAD systems will provide more than one type of ellipse, such as isometric ellipses.

**Engineering and Science Applications of Ellipses** The ellipse has a reflective property similar to that of a parabola. Light or sound emanating through one focus is reflected to the other, and this is useful in the design of some types of optical equipment. *Whispering galleries*, such as the Rotunda in the

## Design in Industry

### New Tools Help Link Computer-Aided Industrial Design with Mechanical CAD

Increased efficiency in design and engineering operations means a tighter data link between the initial design work done by the industrial designers and the engineering on the design team. Tighter integration is desired between computer-aided industrial design (CAID) and traditional CAD because it allows the industrial designer's vision to carry through to product engineering and manufacturing, ensuring that what the design intends is what gets built. Unfortunately, the transfer of model data from CAID systems to CAD systems has traditionally been so difficult that many firms have not attempted to do it. Instead, model information has to be reconstructed in the CAD system, losing valuable time and introducing unintended changes in the original design.

Though new and better translation tools have been developed, CAID-CAD integration issues are also affected by basic human issues. How models are created in their respective packages, how they are documented, and how this model information is communicated between designers and engineers all affect how successful the translation is likely to be. Effective integration depends on both new software tools and new ways of thinking about how models are created and managed.

Even though both CAID and CAD tools define model shapes mathematically, that is where the similarity often ends. CAID is a tool for creative expression. Industrial designers need to be able to experiment with shape and form with few restrictions. On the other hand, engineers using CAD tools implement a rigor and discipline to the models at this stage in the design.

CAID programs such as Alias/Wavefront's Studio Tools, PTC's ICEM Surf, and SDRC's Imageware provide the kind of freeform surface modeling tools that let designers create

organic forms on the screen. They facilitate the creative process by allowing users "push and pull" surfaces and immediately see the results. While the model may be mathematically precise, the designers might never type in a specific coordinate or size. The goal for an industrial designer is to capture a look and feel for the model. While designers may be very concerned with the usability metrics of the model by the end user, they may be much less concerned with the structural integrity of components and manufacturability of the product.

Engineers using CAD tools, on the other hand, apply a different philosophy. Their job is to capture the intent of the industrial designers and convert it into an engineered product. Precise variables, such as clearances, tolerances, wall thicknesses, and draft angles, now become important parameters to consider. The goal for the engineer is to apply this level of precision while adjusting geometries to meet engineering and manufacturing benchmarks, and still preserve the designer's concept.

Given the challenges of preserving the design intent while applying engineering constraints, problems in converting the CAID model add another level of complexity. In an ideal world, the CAID surface model (in essence, a "sketch model") would seamlessly be converted into a CAD solid model that the engineer can work on. One of the problems is that to the CAD solid modeler, the surface model must be "watertight." This means that there can be no gaps between patches in the surface model. These gaps might not be visible on the computer screen, but mathematically it creates difficulties for the solid modeler to interpret and convert. Farther down the road, these gaps can also create difficulties in generating CAM tool paths, since the tool paths can "fall" into the gaps between surfaces.

Capitol Building in Washington, D.C. (Figure 3.36) and the Mormon Tabernacle in Salt Lake City, Utah, are designed using elliptical ceilings. In a whispering gallery, sound emanating from one focus is easily heard at the other focus.

Ellipses are also useful in astronomy. Kepler's first law states that the orbit of each planet in the solar system is an ellipse, with the sun at one focus. In addition, satellites sent into Earth's orbit travel in elliptical orbits about the Earth.

## 3.7 Roulettes

**Roulettes** are curves generated by the rolling contact of one curve or line on another curve or line. Any point attached to the rolling curve or line will describe the roulette curve. The moving point is called the *generating*

*point*. The roulette is constructed by moving the rolling curve or line to a number of new positions, marking the corresponding positions of the generating point, and drawing a curve connecting those points. There are an infinite variety of roulettes, some of which are more important than others in engineering design, such as in the design of machine elements, instruments, and mechanical devices. The most common types of roulettes used in engineering are spirals, cycloids, and involutes.

### 3.7.1 Spirals

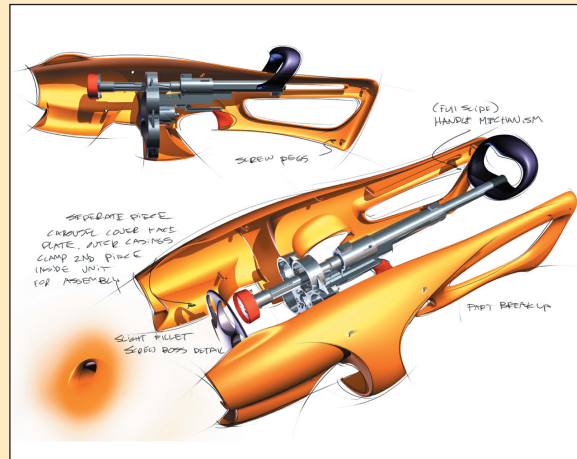
A **spiral** is a single-curved surface that begins at a point called a *pole* and becomes larger as it travels in a plane around the origin (Figure 3.37). A spiral is sometimes referred to as a *spiral of Archimedes*, which is the curve on a

Newer CAD translators can automatically “heal” gaps between surfaces or give the operator the ability to manually “stitch” them closed. However, if the designer has created a surface model with hundreds of patches and a similar number of gaps, the engineer may decide that the time needed to repair the model is not worth it. This is an example of where good modeling practice on the part of the designer can make a difference. Creating a model with the fewest number of patches and using modeling techniques that reduce gap formation will facilitate later model translation.

The gap problem can also be alleviated by synchronizing the “gap tolerances” settings in the CAID and CAD modelers. The gap tolerance determines what is seen as one surface or two distinct surfaces by the model. Curve continuity tolerance differences can also lead to problems in defining what is a continuous surface and what are two difference surfaces.

Another key strategy in successful model translation is to pick an appropriate vehicle for translation. Traditionally, neutral file formats such as STEP or IGES have been used for translation. As much as this method has been used, there are still problems. Among other things, the model data needs to be translated twice: once from the CAID format to the neutral format and then again to the CAD format. Each translation has the potential for introducing errors into the model. CAID and CAD vendors have addressed this issue by beginning to provide direct translators. For example, Alias|Wavefront has worked with major CAD vendors to create “direct connects” between its Studio software and Catia, Unigraphics, and I-DEAS.

In addition to direct translators, some CAID tools allow the user to use “presets” that specify, prior to creating the surface model, what CAD package will eventually receive the



(Courtesy of Frog Design.)

CAID model. These settings help create a surface model with the appropriate level of tolerances so that it can easily be received by the target CAD system.

Even with the help of new software tools, there is still a “cultural divide” between the industrial designers creating the initial concept models and the engineers creating an engineered and manufacturable product. Better understanding between these two key players in the product design process, and new translation tools, will help heal the divide between CAID and CAD.

Source: Adapted from Potter, Caren D., “The CAID Connection,” Computer Graphics World, March 2000, pp. 21–27

heart cam that converts uniform rotary motion into uniform reciprocal motion.

### 3.7.2 Cycloids

A **cycloid** is the curve generated by the motion of a point on the circumference of a circle as the circle is rolled along a straight line in a plane (Figure 3.38). The length of the cycloid curve is defined as exactly equal to four diameters of the rolling circle, and the area between the cycloid and the baseline AB equals three times the area of the rolling circle.

An *epicycloid* is formed when the circle is rolled on the outside of another circle. A *hypocycloid* is formed when the circle is rolled on the inside of another circle. A *trochoid* is the curve formed by a point on the radial

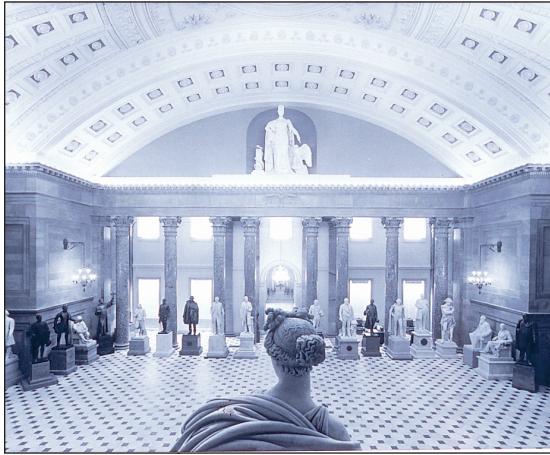
spoke of a circle as the circle rolls along tangent to a straight line.

#### Practice Exercise 3.7

Make a circular cardboard disk with a hole punched near its perimeter. With a pencil in the hole, run the circle along a straightedge to create a cycloid. Do the same but run the circle along the internal (epicycloid) and external (hypocycloid) perimeter of another circle. (Similar effects can be created using a Spirograph™.)

Cycloid curves are commonly used in kinematics (motion studies) and in mechanisms that work with rolling contact. Epicycloids and hypocycloids are often used in rotary pumps, blowers, and superchargers.



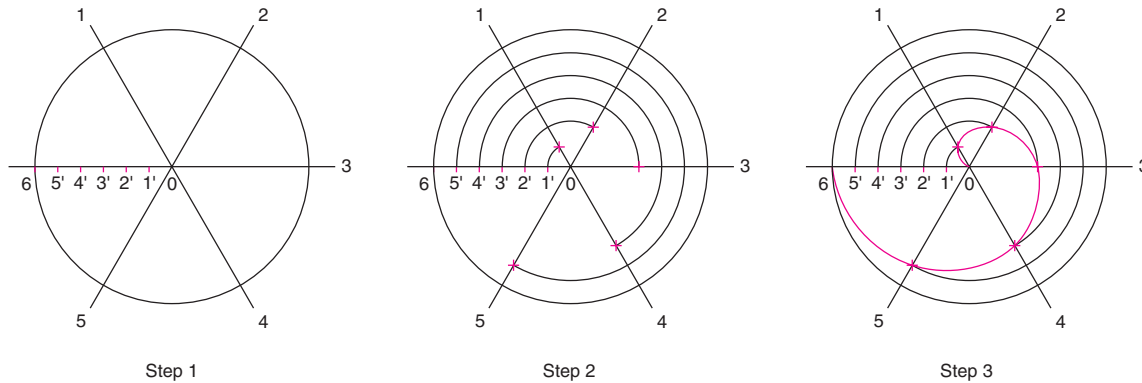


**Figure 3.36**

**Ellipse application**

The Rotunda in the Capitol Building in Washington, D.C., has an elliptical ceiling.

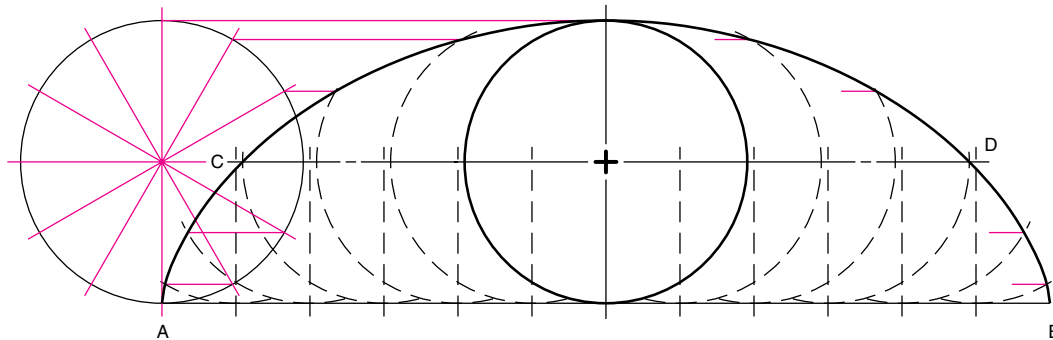
(© Photri Inc.)



**Figure 3.37**

**A spiral of Archimedes**

A single-curved surface that begins at a point called a pole and becomes larger as it travels in a plane around the origin.



**Figure 3.38**

**Generation of a cycloid**

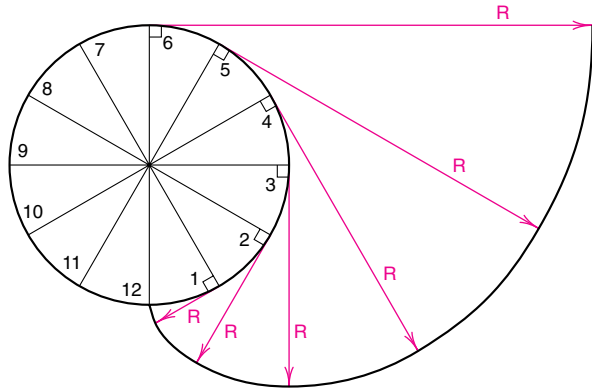
A cycloid is generated by the motion of a point on the circumference of a circle that is rolled along a straight line.

**3.7.3 Involutés**

An **involute** is the spiral path of a point on a string unwinding from a line, circle, or polygon. Involutés of circles are used in the design of spur gears (Figure 3.39). The contact surfaces between gear teeth are designed as involutes. The involutes permit motion to be transmitted smoothly and at a constant velocity, which is important in mechanisms using gears. Figure 3.40 is an involute gear tooth profile constructed by the method shown in Figure 3.39. The curve on the profile of the gear tooth is the involute.

**Practice Exercise 3.8**

Wrap a string around a coffee can. Attach a pencil to the free end of the string. Place the can on a piece of paper and, holding the string tight, draw while unwrapping the string. Change diameters of the can to create different involutes.

**Figure 3.39****Involute**

Constructing the involute of a circle

### 3.8 Double-Curved Lines, Including Helices

A *double-curved line* is a curve generated by a point moving uniformly at both an angular and a linear rate around a cylinder or cone. The line of intersection between two curved solids forms a double-curved line. Cylindrical and conical helices are examples of double-curved lines.

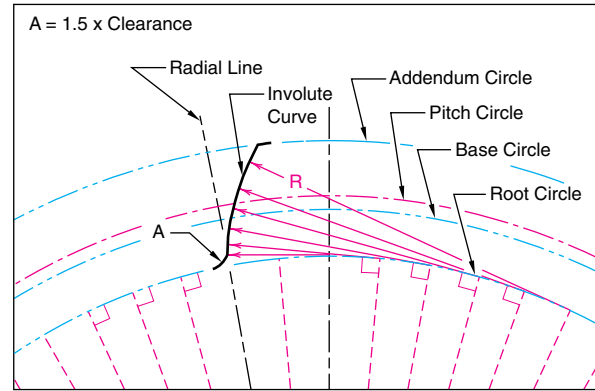
A **helix** is the curve formed by a point moving uniformly at both an angular and a linear rate around a cylinder or cone. Because of the uniform angular rate, a helix is a curve of constant slope, called the *helix angle*. A *cylindrical helix* is the curve formed by a point moving uniformly at both an angular and a linear rate around a cylinder. The distance that the point moves parallel to the axis during one revolution is called the *lead* or *pitch*. A screw thread is a common application of a cylindrical helix, as are spiral staircases, worm gears, drill bits, spiral milling cutters, springs, and conveyors (Figure 3.41). A *conical helix* is the curve formed by a point moving uniformly at both an angular and a linear rate around a cone.

Some CAD systems can automatically generate a helix with a HELIX command when the diameter, axis, number of turns, and direction of rotation are specified.

### 3.9 Freeform Curves

Simple curves are circles, arcs, and ellipses. More complex curves used in engineering design are called **freeform curves**. The automobile shown in Figure 3.42 uses many freeform curves in the body design.

Freeform curves are constructed with a traditional tool called a *spline*. A spline is a flexible strip of plastic or other material that can change shape easily to pass through a

**Figure 3.40****Involute application**

Part of the gear tooth profile is an involute.

**Figure 3.41****Helix application**

The screw thread found on nuts and bolts is a common application of a cylindrical helix.

(© Photri Inc.)

series of key design points (control points) marked on the drawing. The spline curve is one of the most important curves used in the aircraft and shipbuilding industries. The cross section of an airplane wing or a ship's hull is a spline curve. Also, spline curves are commonly used to define the path of motion for a computer animation.

For CAD systems, three types of freeform curves were developed: splines, Bezier curves, and B-spline curves. These curves can be described by *parametric equations*, in which the X and Y coordinates of the control points are computed as a function of a third variable called a *parameter*. If the curves are created by smoothly connecting the

**Figure 3.42****Freeform surfaces**

An automobile body reflects many freeform curves.

(© Davis Barber: PhotoEdit.)

control points, the process is called *interpolation* (Figure 3.43A). If the curves are created by drawing a smooth curve that goes through most, but not all, of the control points, the process is called *approximation* (Figure 3.43B).

**3.9.1 Spline Curves**

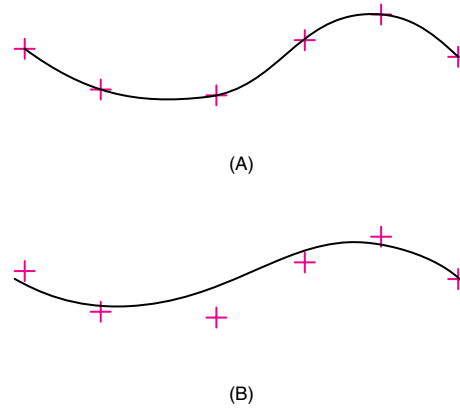
A **spline curve** is a smooth, freeform curve that connects a series of control points (Figure 3.44A). Changing any single control point will result in a change in the curve, so that the curve can pass through the new point. (Figure 3.45A)

**3.9.2 Bezier and B-Spline Curves**

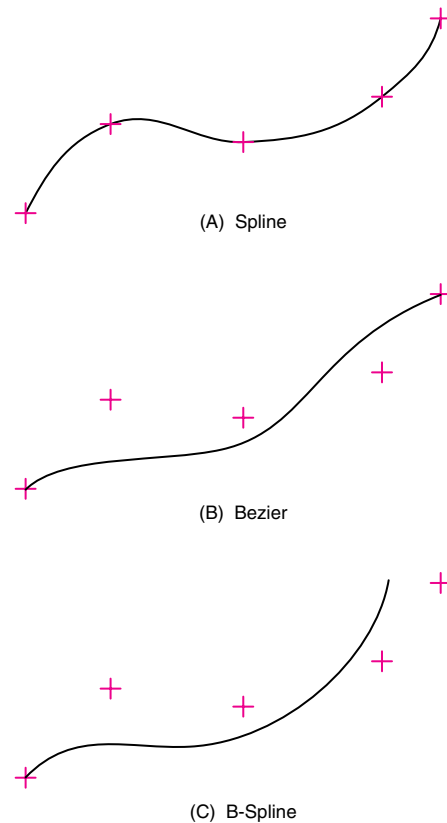
In computer graphics, it is possible to create an easily modified smooth curve that passes close to but not through the control points. These curves, called *approximations*, include the Bezier and B-spline curves.

P. E. Bezier, of the French automobile company Renault, developed an approximation curve to give designers greater flexibility than was available with interpolation techniques. This mathematical curve became known as the **Bezier curve**, which uses a set of control points that only approximate the curve (Figure 3.44B). The Bezier curve is popular in design because the first and last control points are on the curve. However, changing the position of any control point causes a reshaping of the entire curve, so modifications are not localized; that is, there is no *local* control (Figure 3.45B).

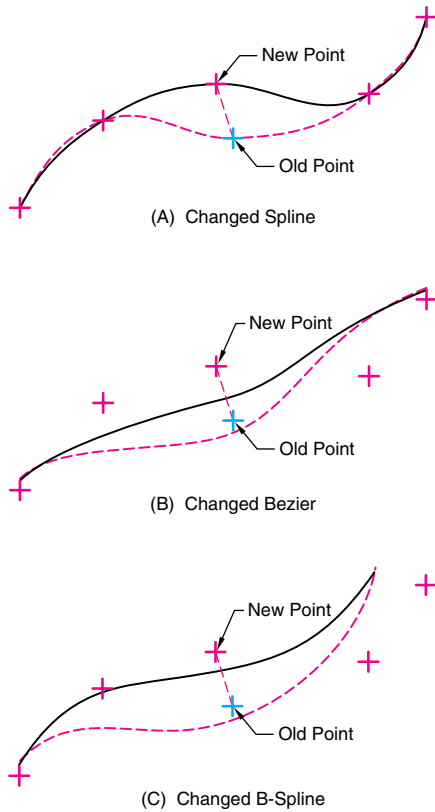
Further developments led to the **B-spline curve**, which approximates a curve to a set of control points and does provide for local control (Figure 3.44C). The B-spline uses

**Figure 3.43****Curves**

Two different curves are created, depending on whether interpolation (A) or approximation (B) is used.

**Figure 3.44****Freeform curves**

Spline, Bezier, and B-spline curves create different results from the same set of control points.



**Figure 3.45**

**Result of changing control points**

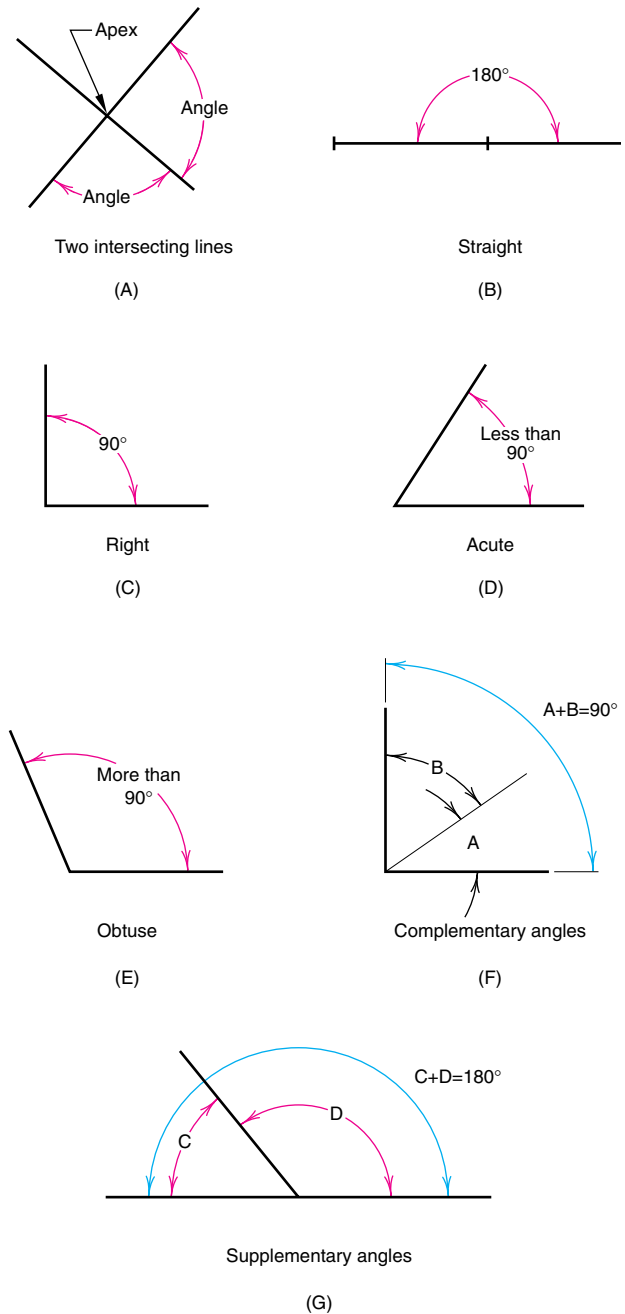
Changing a control point on a curve produces different results, depending on the type of curve used.

a special set of *blending* functions that have only local influence and depend on only a few neighboring control points. This means that a local change does not result in a global change to the entire curve (Figure 3.45C).

**3.10 Angles**

**Angles** are formed by the apex of two intersecting lines or planes. Angles are categorized by their degree measurement (Figure 3.46).

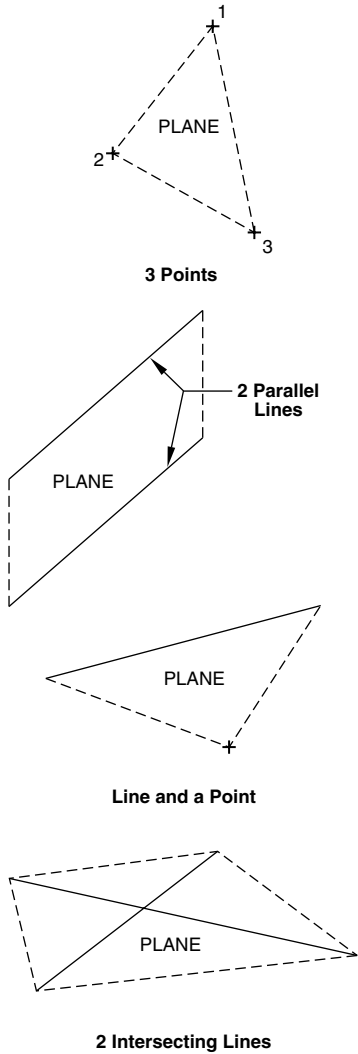
- Straight angle.* An angle of 180 degrees.
- Right angle.* An angle of 90 degrees.
- Acute angle.* An angle of less than 90 degrees.
- Obtuse angle.* An angle of more than 90 degrees.
- Complementary angles.* Two adjacent angles whose sum equals 90 degrees.
- Supplementary angles.* Adjacent angles whose sum equals 180 degrees.



**Figure 3.46**

**Angles**  
Classification of angles.





**Figure 3.47**

**Planes**

Planes are formed by three points, two parallel lines, a line and a point, or two intersecting lines.

**3.11 Planes**

A **plane** is a two-dimensional surface that wholly contains every straight line joining any two points lying on that surface. Although many drawings are created from simple geometric primitives, such as lines and curves, many real-world designs are made of *planar surfaces*. Theoretically, a plane has width and length but no thickness. In practice, planar surfaces have some thickness.



**Figure 3.48**

**3-D Surface**

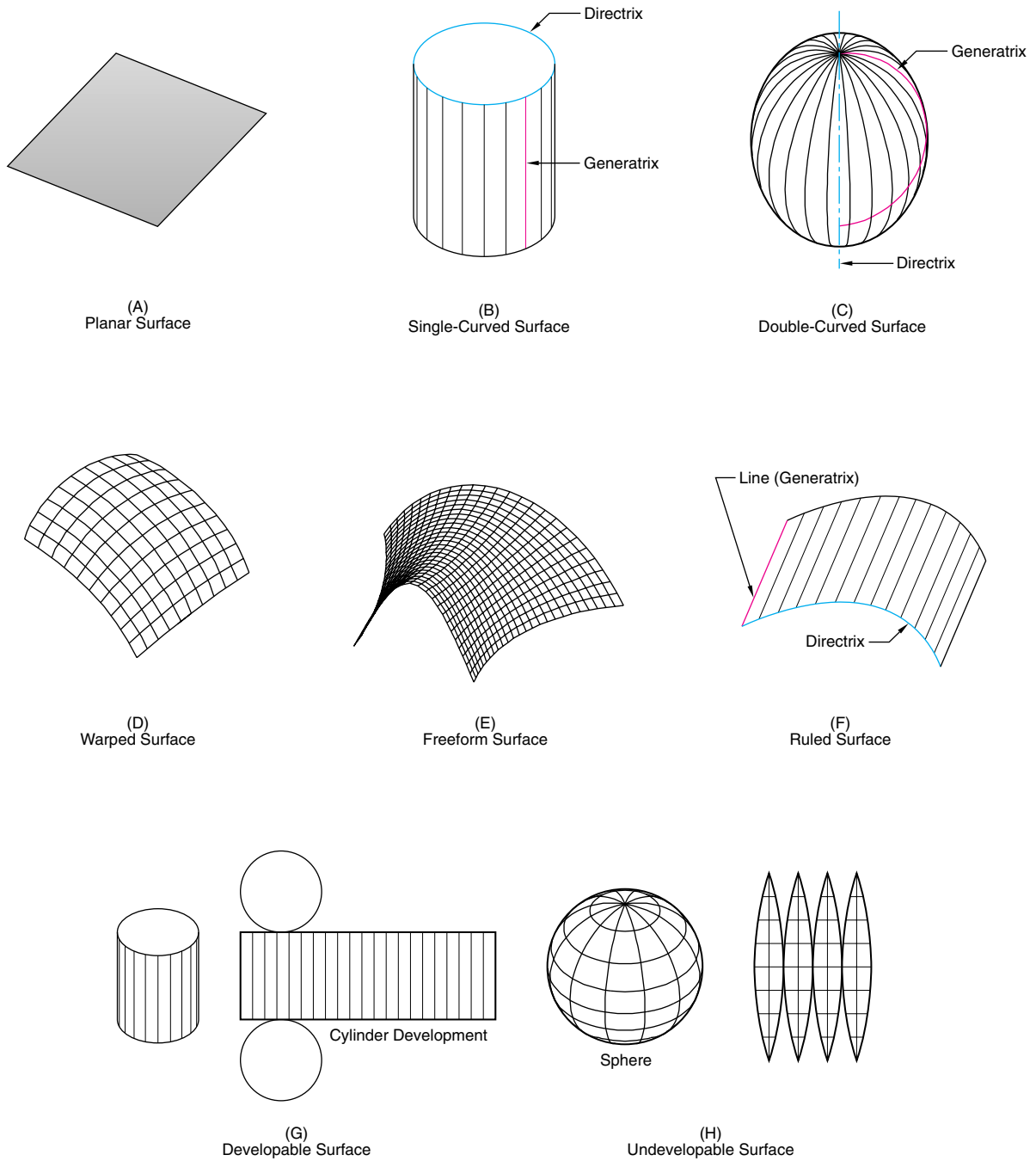
An airplane wing is a good example of a complex 3-D surface. (© Photri, Inc.)

An *infinite plane* is an unbounded two-dimensional surface that extends without a perimeter in all directions. A *finite plane* is a bounded two-dimensional surface that extends to a perimeter in all directions. A plane can be defined by three points not in a straight line; two parallel lines; a line plus a point that is not on the line or its extension; or two intersecting lines (Figure 3.47).

**3.12 Surfaces**

A **surface** is a finite portion of a plane, or the outer face of an object bounded by an identifiable perimeter. The fender of an automobile and the airplane wing are examples of complex 3-D surfaces (Figure 3.48). Just as a line represents the path of a moving point, a surface represents the path of a moving line, called a **generatrix**. A generatrix can be a straight or curved line. The path that the generatrix travels is called the **directrix**. A directrix can be a point, a straight line, or a curved line (Figure 3.49F).

The shape of a surface is determined by the constraints placed on the moving line used to generate the surface. Surfaces are generally classed as planar, single-curved, double-curved, warped, and freeform.



**Figure 3.49**

**Surfaces**

Examples of surfaces commonly used in engineering design.

A **planar surface** is a flat, two-dimensional bounded surface (Figure 3.49A). A planar surface can be defined as the motion of a straight-line generatrix that is always in contact with either two parallel straight lines, two intersecting lines, or a line and a point not on the line.

A **single-curved surface** is the simple-curved bounded face of an object produced by a straight-line generatrix revolved around an axis directrix (yielding a cylinder) or a vertex directrix (yielding a cone) (Figure 3.49B).

A **double-curved surface** contains no straight lines and is the compound-curved bounded face of an object produced by an open or closed curved-line generatrix revolved around an axis directrix (yielding a sphere or ellipsoid), a center directrix (yielding a torus), or a vertex directrix (yielding a paraboloid or a hyperboloid) (Figure 3.49C).

A **warped surface** is a single- and double-curved transitional surface (cylindroid, conoid, helicoid, hyperbolic paraboloid), often approximated by triangulated surface sections that may join other surfaces or entities together (Figure 3.49D).

A **freeform surface** follows no set pattern and requires more sophisticated underlying mathematics (Figure 3.49E).

Surfaces can also be classified as ruled, developable, or undevelopable, as follows:

A **ruled surface** is produced by the movement of a straight-line generatrix controlled by a directrix to form a planar, single-curved, or warped surface (Figure 3.49F).

A **developable surface** can be unfolded or unrolled onto a plane without distortion. Single-curved surfaces, such as cylinders and cones, are developable (Figure 3.49G).

An **undevelopable surface** cannot be unfolded or unrolled onto a plane without distortion. Warped and double-curved surfaces, such as a sphere or an ellipsoid, cannot be developed except by approximation (Figure 3.49H). For example, the Earth is nearly a sphere, and representing its land forms on flat paper has taken cartographers centuries to develop. On some types of maps, the land forms near the poles are drawn much larger than they really are, to compensate for the curvature that can't be shown.

The advancement of computer graphics has resulted in the development of special types of surfaces that are mathematically generated to approximate complex freeform surfaces. These complex surfaces are created by a series of patches, where a **patch** is a collection of points bounded by curves and is the simplest mathematical ele-

ment that can be used to model the surface. Some of the more common computer-generated freeform surfaces are:

- Fractal
- B-spline
- Coons'
- Bezier
- Nonuniform Rational B-spline (NURBS)

These names reflect the underlying geometry used to generate the curves. For example, B-spline curves are used to generate a B-spline surface patch.

Traditionally, orthographic views are used to represent surfaces. With CAD, it is possible to create mathematical models of very complex surfaces that would be impossible to represent using traditional tools. The computer model can be used to determine surface characteristics such as area. One such surface, called a **surface of revolution**, is created by revolving a curve (generatrix) in a circular path (directrix) about an axis. These types of surfaces are used on any part that requires surfaces with arc or circular cross sections. Another method of creating surfaces with CAD is to sweep generator entities, such as circles, arcs, and lines, along director entities, as shown in Figure 3.50. This method of creating surfaces is called **swept surfaces**. Swept surfaces are often used for product and tooling design.

### 3.12.1 Two-Dimensional Surfaces

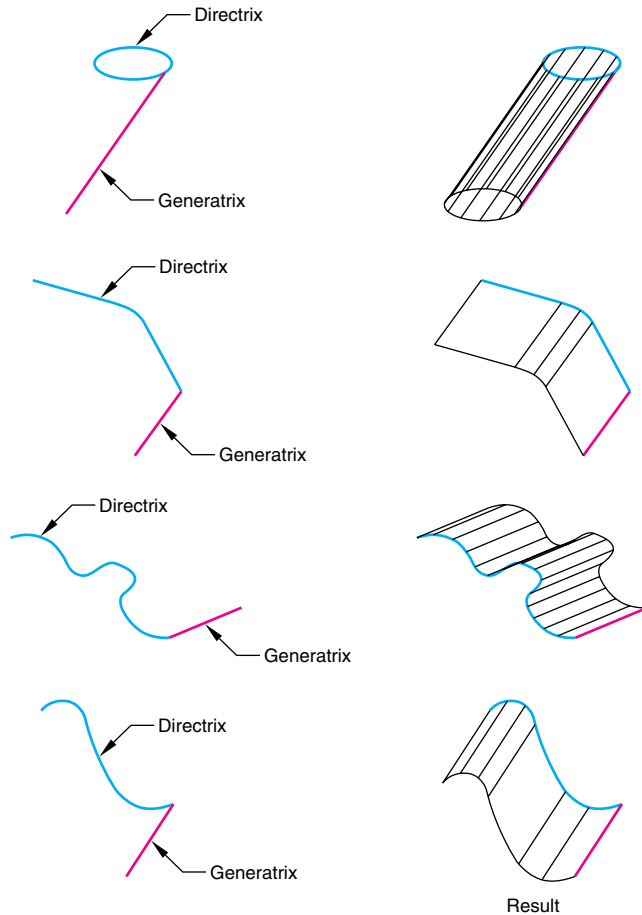
Two-dimensional surfaces are simple ruled surfaces and include closed curves, quadrilaterals, triangles, and regular polygons. (See Figure 3.15.) These geometric primitives are the building blocks for more complex surfaces and solids. For example, CAD creates more complicated 3-D forms through extrusion and sweeping operations, such as creating a rectangular prism by extruding a rectangular surface.

**Quadrilaterals** **Quadrilaterals** are four-sided plane figures of any shape. The sum of the angles inside a quadrilateral will always equal 360 degrees. If opposite sides of the quadrilaterals are parallel to each other, the shape is called a parallelogram. The square, rectangle, rhombus, and rhomboid are **parallelograms**. Quadrilaterals are classified by the characteristics of their sides (Figure 3.51).

*Square.* Opposite sides parallel, all four sides equal in length, all angles equal.

*Rectangle.* Opposite sides parallel and equal in length, all angles equal.



**Figure 3.50****Swept surfaces**

Generating swept surfaces by sweeping generator entities along director entities.

*Rhombus.* Opposite sides parallel, four sides equal in length, opposite angles equal.

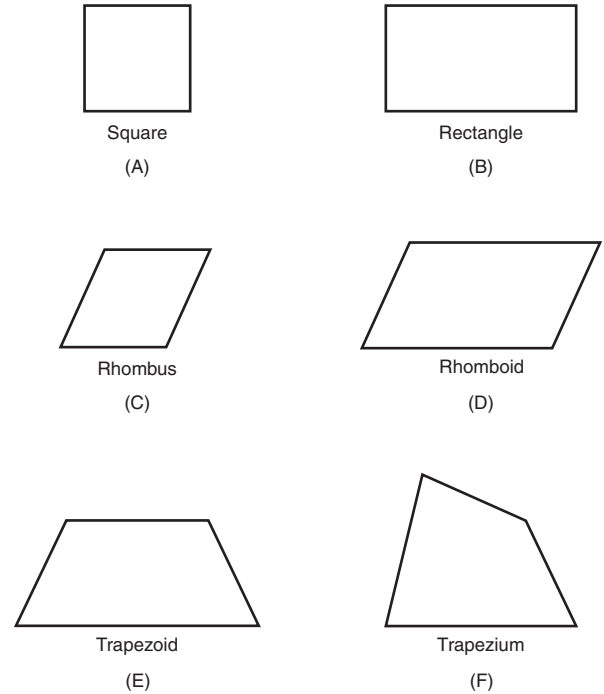
*Rhomboid.* Opposite sides parallel and equal in length, opposite angles equal.

*Regular trapezoid.* Two sides parallel and unequal in length, two sides nonparallel but equal in length, base angles equal, vertex angles equal.

*Irregular trapezoid.* Two sides parallel, no sides equal in length, no angles equal.

*Trapezium.* No sides parallel or equal in length, no angles equal.

Quadrilaterals are constructed using straightedges, triangles, and a compass to create parallel lines and to measure equal angles.

**Figure 3.51****Quadrilaterals**

Classification of quadrilaterals.

**Regular Polygons** A **polygon** is a multisided plane of any number of sides. If the sides of the polygon are equal in length, the polygon is called a **regular polygon**. Regular polygons can be inscribed in circles. To determine the angle inside a polygon, use the equation  $S = (n - 2) \times 180$  degrees, where  $n$  equals the number of sides. Regular polygons are grouped by the number of sides (Figure 3.52).

*Triangle (equilateral).* Three equal sides and angles.

*Square.* Four equal sides and angles.

*Pentagon.* Five equal sides and angles.

*Hexagon.* Six equal sides and angles.

*Heptagon.* Seven equal sides and angles.

*Octagon.* Eight equal sides and angles.

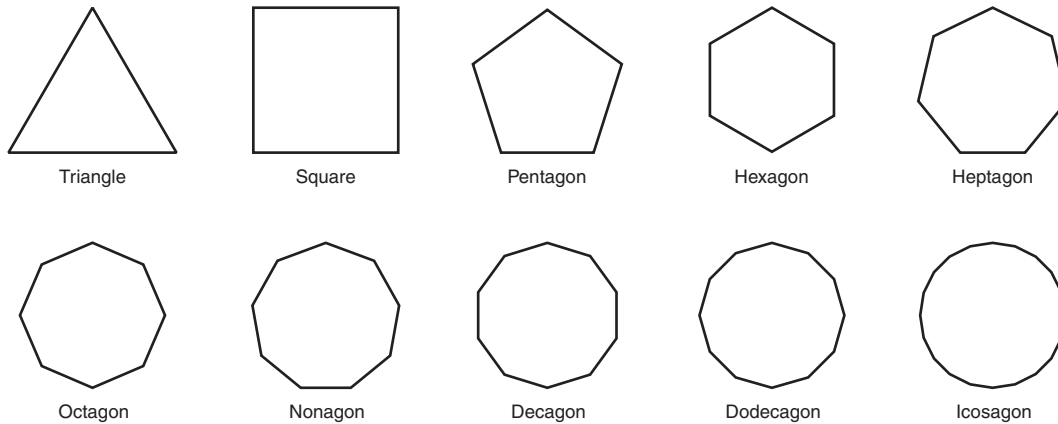
*Nonagon.* Nine equal sides and angles.

*Decagon.* Ten equal sides and angles.

*Dodecagon.* Twelve equal sides and angles.

*Icosagon.* Twenty equal sides and angles.

**Triangles** A **triangle** is a polygon with three sides. The sum of the interior angles equals 180 degrees. The **vertex** is the point at which two of the sides meet. Triangles are

**Figure 3.52****Polygons**

Classification of regular polygons.

named according to their angles (right, obtuse, acute) or the number of equal sides (Figure 3.53).

*Equilateral triangle.* Three equal sides and three equal interior angles of 60 degrees.

*Isosceles triangle.* At least two equal sides.

*Scalene triangle.* No equal sides or angles.

*Right triangle.* Two sides that form a right angle (90 degrees), and the square of the hypotenuse is equal to the sum of the squares of the two sides (Pythagoras Theorem).

*Obtuse triangle.* One obtuse angle (greater than 90 degrees).

*Acute triangle.* No angle larger than 90 degrees.

Right triangles are acute triangles. A right triangle can be either an isosceles triangle, where the other two angles are 45 degrees, or a 30/60 triangle, where one angle is 30 degrees and the other is 60 degrees.

**Pentagons** A pentagon has five equal sides and angles.

**Hexagons** A hexagon has six equal sides and angles. Hexagons are constructed by using a 30/60-degree triangle and a straightedge to construct either circumscribed or inscribed hexagons around or in a given circle.

The construction techniques described are useful for drawing the heads of hexagonal nuts and bolts. Nuts and bolts are designated by the distance across the flats. For example, for a 1" hexagonal bolt head, draw a 1" diameter circle, then circumscribe a hexagon around the circle.

For more detailed information on drawing such fasteners, see Chapter 10.

**3.12.2 Ruled Surfaces**

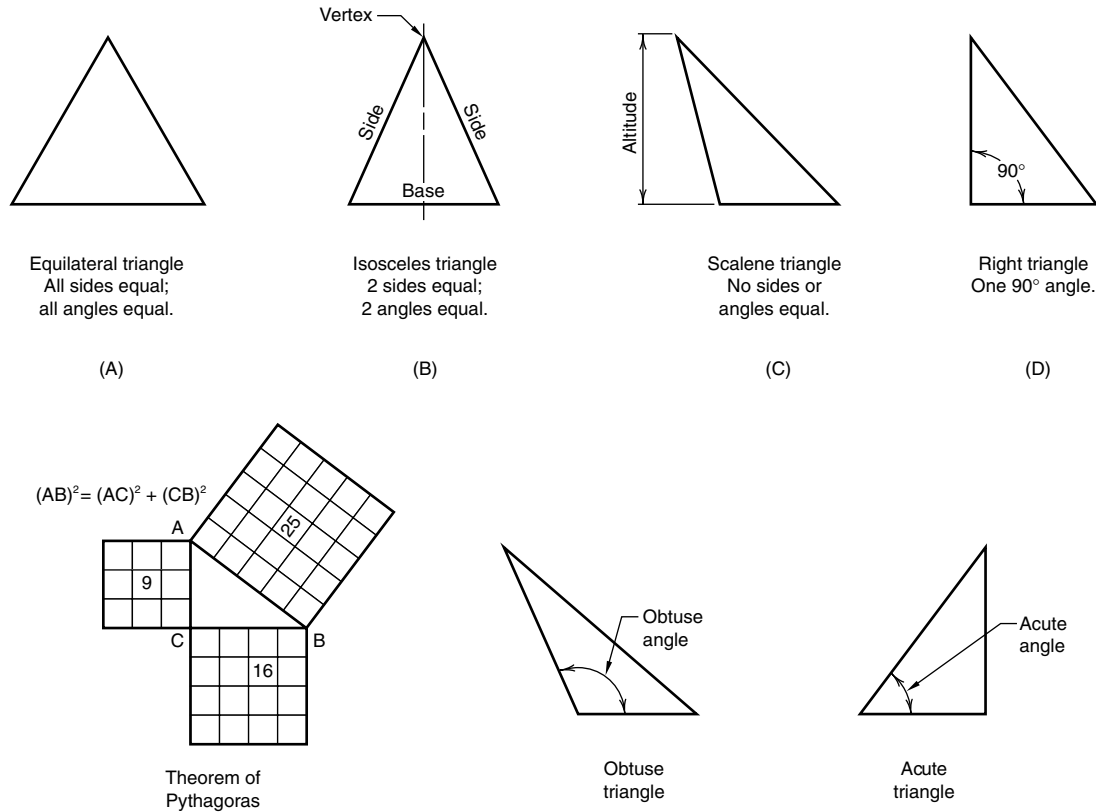
Polyhedra, single-curved surfaces, and warped surfaces are classified as ruled surfaces (Figure 3.49). All ruled surfaces, except for warped surfaces, are developable.

With traditional tools, simple plane surfaces are drawn using triangles and straightedges.

Some CAD systems have surface modeling programs that can be used to create simple plane surfaces and more complicated ruled surfaces.

**Single-Curved Surfaces** *Single-curved surfaces* are generated by moving a straight line along a curved path such that any two consecutive positions of the generatrix are either parallel (cylinder), intersecting (cone), or tangent to a double-curved line (convolute). (These surfaces can also be generated by sweeping a curved generatrix along a straight-line directrix.) The cone, cylinder, and convolute are the only types of surfaces in this class and they all are developable. Most CAD systems will display a single-curved surface with a series of *elements*, *facets*, or *tessellations*, and some can automatically develop the surface (Figure 3.54).

**Cones** There are three basic classifications of **cones** (Figure 3.55). If the axis is perpendicular to the base, the

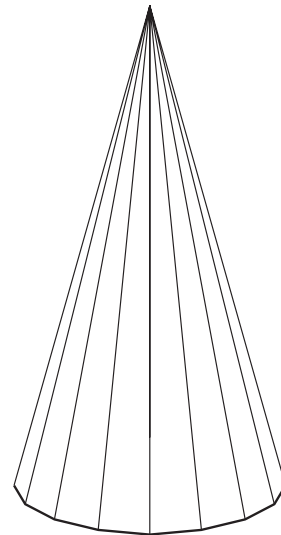
**Figure 3.53****Triangles**

Classification of triangles.

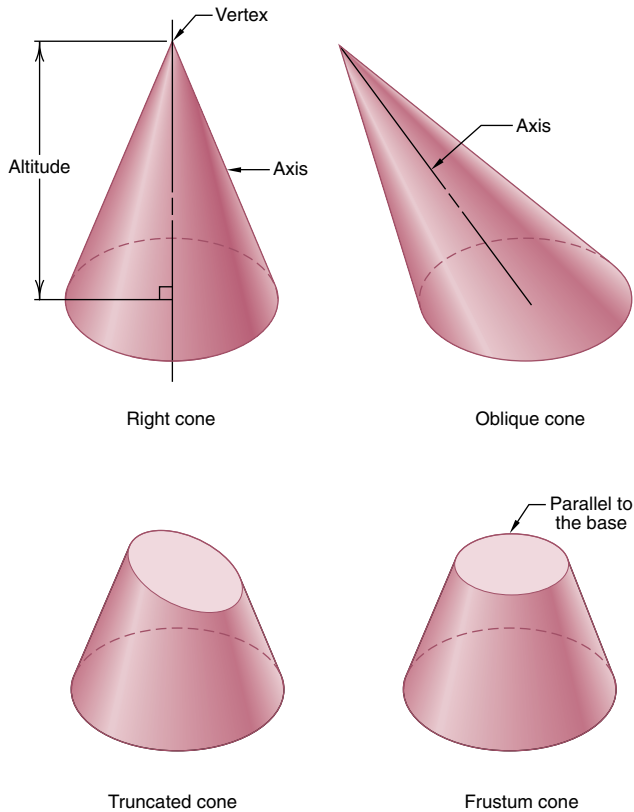
axis is called the *altitude* and the cone is called a *right cone*. If the axis is not perpendicular to the base, the cone is called an *oblique cone*. If the tip of the cone is cut off, it is called a *truncated cone* or a *frustum* of a cone.

There are many applications for cones in engineering design, including the *nose cone* of rockets; transition pieces for heating, ventilating, and air-conditioning systems; conical roof sections; and *construction cones* used to alert people to construction areas.

The directrix for a cone may be either a single or double curve. The directrix may also assume any irregular shape, but is normally circular or elliptical. Cones are therefore further classified by the path of the generatrix: circular, elliptical, nephroidal, deltoidal, astroidal, cardioidal, and free curve.

**Figure 3.54****Faceted representation of a cone**

The computer display of a single-curved surface, such as a cone, will often show the surface as elements or tessellation lines.



**Figure 3.55**

### Cones

Classification of cones.

Most 3-D CAD systems can easily produce many of the cones described in this section. One approach with CAD uses the 3-D primitive geometry commands. For example, to create a circular cone, the primitive command `CONE` is used to define the location and circumference of the base and the location of the vertex. A noncircular cone is created by constructing the noncircular base, then extruding that form along a defined axis to a vertex point.

**Cylinders** A **cylinder** is a single-curved ruled surface formed by a vertical, finite, straight-line element (generatrix) revolved parallel to a vertical or oblique axis directrix and tangent to a horizontal circular or elliptical directrix. The line that connects the center of the base and the top of a cylinder is called the *axis*. If the axis is perpendicular to the base, the cylinder is a *right cylinder*. If the axis is not perpendicular to the base, the cylinder is an *oblique*

*cylinder*. A multiview drawing of a right circular cylinder shows the base curve (a circle), the extreme elements, and the axis (Figure 3.56).

If the base curve is a circle, the cylinder is circular. If the base curve is an ellipse, the cylinder is elliptical.

### Practice Exercise 3.9

Take four clay or foam right-angle cones and cut them at angles appropriate to make circular, elliptical, parabolic, and hyperbolic sections. Look at the cut sections from a perpendicular viewpoint and along the major axis of the cone. Viewing along the major axis of the cone, which sections look circular? Which look like a line? Which have other shapes?

Take four clay, foam, or paper cylinders of the same altitude and base diameter as the cones, and cut them at identical angles. Compare the resulting sections (side-by-side and face-to-face). Are any the same size? Are any the same shape? View these new sections along a normal axis and along the major axis.

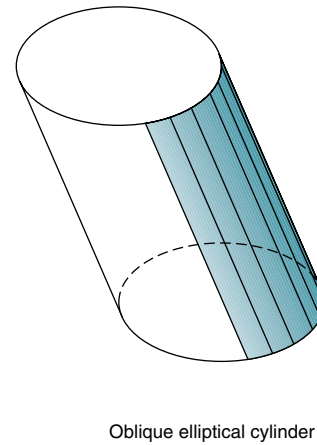
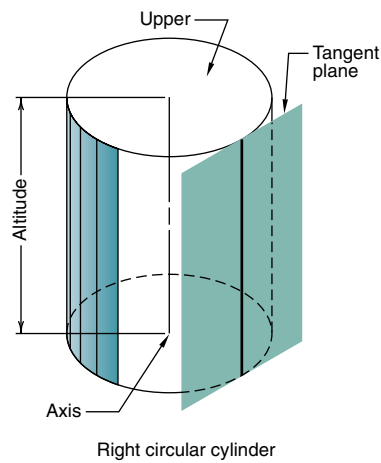
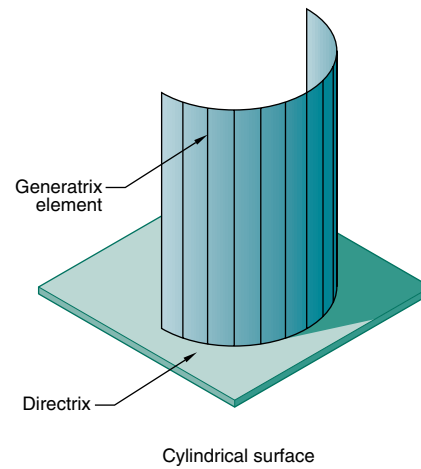
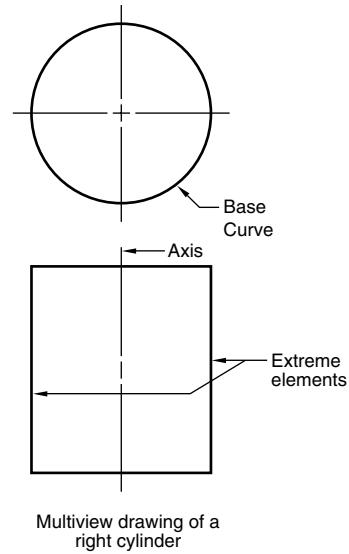
Repeat the above exercise with 3-D computer models. Use Boolean subtraction operations or a `SECTION` command.

**Convolutes** A **convolute** is a single-curved surface generated by a straight line moving such that it is always tangent to a double-curved line. Figure 3.57 shows the generation of a convolute using a helix curve (the double-curved line) as the directrix, which results in a helical convolute.

**Polyhedra** A **polyhedron** is a symmetrical or asymmetrical 3-D geometric surface or solid object with multiple polygonal sides. The sides are plane ruled surfaces (Figure 3.58) and are called *faces*, and the lines of intersection of the faces are called the *edges*. **Regular polyhedra** have regular polygons for faces. There are five regular polyhedrons: tetrahedron, hexahedron, octahedron, dodecahedron, and icosahedron. As solids, these are known as the *five platonic solids*. Some polyhedra, such as the tetrahedron, pyramid, and hexahedron, are easily produced with 3-D CAD programs by using extrusion techniques.

Regular polyhedra are classified by the shape and number of faces, as follows.

**Tetrahedron.** A symmetrical or asymmetrical 3-D surface or solid object with *four* equilateral triangular sides.

**Figure 3.56****Cylinders**

Cylinder classifications.

*Hexahedron.* A symmetrical or asymmetrical 3-D surface or solid object with *six* quadrilateral sides.

*Octahedron.* A symmetrical or asymmetrical 3-D surface or solid object with *eight* equilateral triangular sides.

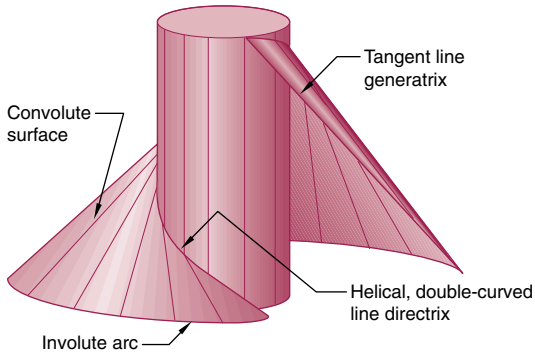
*Dodecahedron.* A symmetrical or asymmetrical 3-D surface or solid object with *twelve* pentagonal sides.

*Icosahedron.* A symmetrical or asymmetrical 3-D surface or solid object with *twenty* equilateral triangular sides.

**Practice Exercise 3.10**

Create real models of polyhedra using the developments found at the end of the book. Make real models of the cube, prism, and tetrahedron. Sketch the multiviews and pictorials of each real model created from the developments.

Using a CAD solid modeler with primitive commands, create solid models of regular polyhedra. View the polyhedra from various viewpoints, with hidden lines shown and then removed.



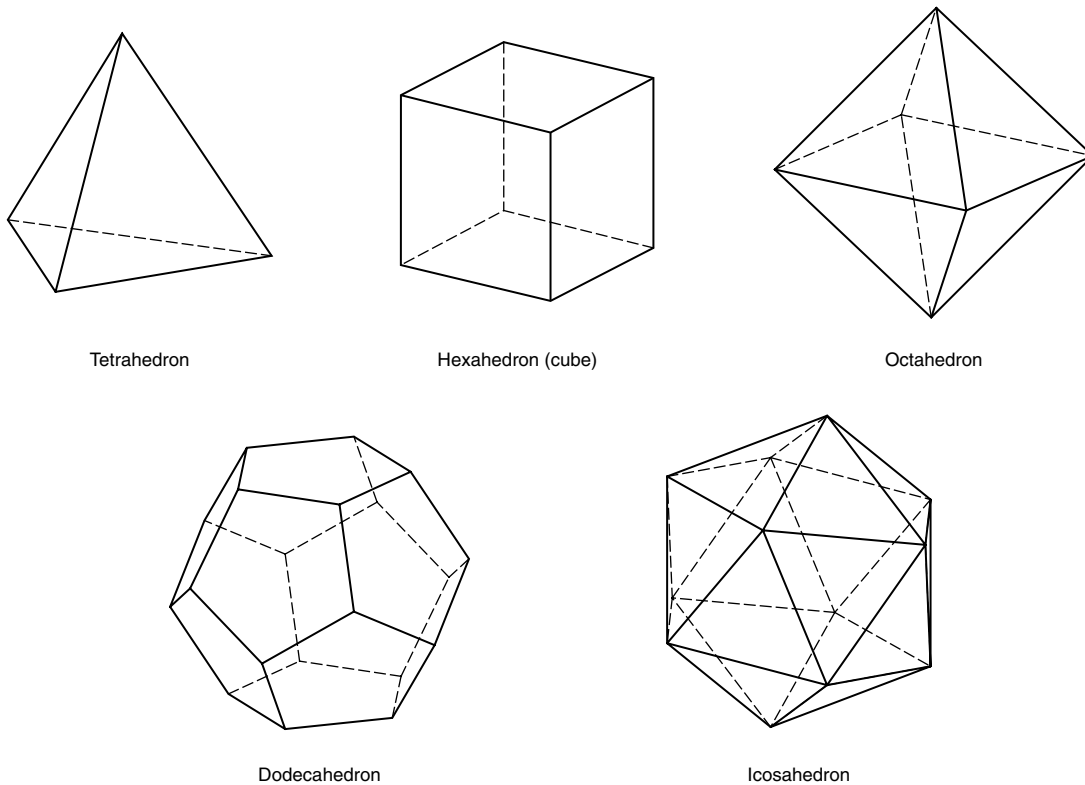
**Figure 3.57**

**Helical convolute**

A convolute surface is formed by the sweep of a straight line tangent to a double-curved line. A helical convolute is a special case formed by the sweep of a line tangent to a helix curve.

**Polygonal Prisms** A **polygonal prism** is a polyhedron that has two equal parallel faces, called its *bases*, and lateral faces that are parallelograms (Figure 3.59). The parallel bases may be of any shape and are connected by parallelogram sides. A line connecting the centers of the two bases is called the *axis*. If the axis is perpendicular to the bases, the axis is called the *altitude* and the prism is a *right prism*. If the axis is not perpendicular to the bases, the prism is an *oblique prism*. A *truncated prism* is one that has been cut off at one end, forming a base that is not parallel to the other base. A **parallelepiped** is a prism with a rectangle or parallelogram as a base. Polygonal prisms are easily produced with 3-D CAD programs by using extrusion techniques.

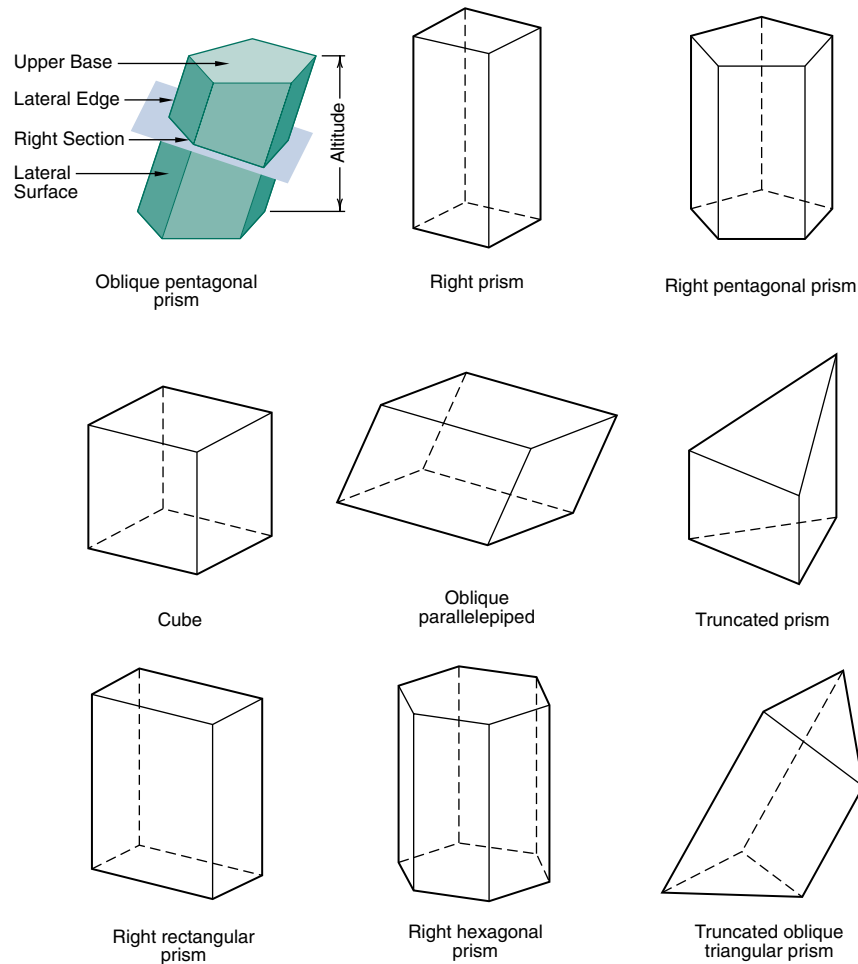
**Pyramids** A **pyramid** is a polyhedron that has a polygon for a base and lateral faces that have a common intersec-



**Figure 3.58**

**Regular polyhedra**

Regular polyhedra are solids formed by plane surfaces that are regular polygonal shapes.



**Figure 3.59**

### Prisms

Classification of prisms.

tion point, called a *vertex*. The *axis* of a pyramid is the straight line connecting the center of the base to the vertex. If the axis is perpendicular to the base, the pyramid is a *right pyramid*; otherwise, it is an *oblique* pyramid (Figure 3.60). A *truncated* or frustum pyramid is formed when a plane cuts off the vertex. The *altitude* of a pyramid is the perpendicular distance from the vertex to the center of the base plane.

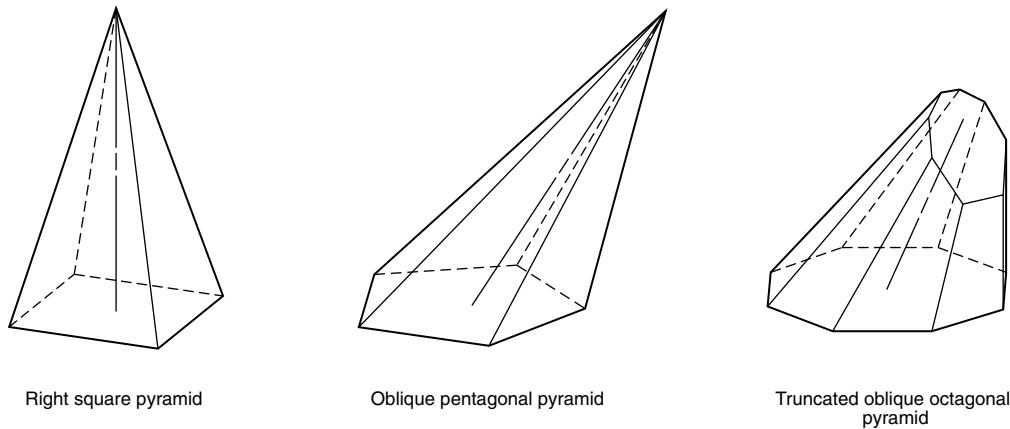
**Warped Surfaces** A *warped surface* is a double-curved ruled 3-D surface generated by a straight line moving such that any two consecutive positions of the line are *skewed* (not in the same plane). Warped surfaces are not developable. Figure 3.61 illustrates an example of a

warped surface. Lines MN and OP are neither parallel nor intersecting. To connect them with a smooth surface, to form a sheetmetal panel for an automobile, for example, a warped surface must be used.

### 3.12.3 Fractal Curves and Surfaces

Benoit Mandelbrot of the IBM Research Center pioneered an investigation into the nature of *self similarity*, which is the condition where a figure is repeated or mimicked by smaller versions of itself. Well-known occurrences of self similarity are coastlines, mountain ranges, landscapes, clouds, galaxy structures, radio noise, and stock market fluctuations. For example, a coastline





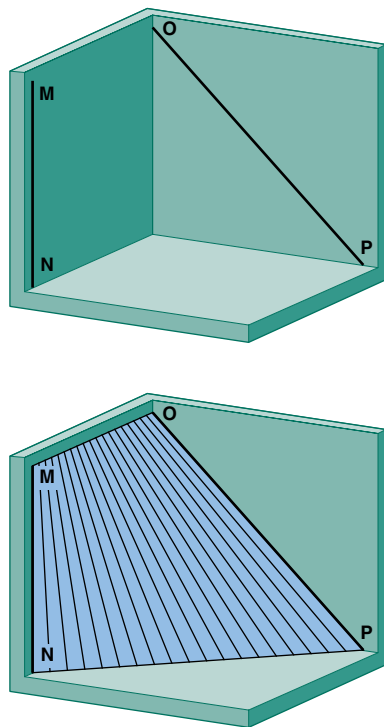
Right square pyramid

Oblique pentagonal pyramid

Truncated oblique octagonal pyramid

**Figure 3.60****Pyramids**

Classification of pyramids.

**Figure 3.61****Warped surface**

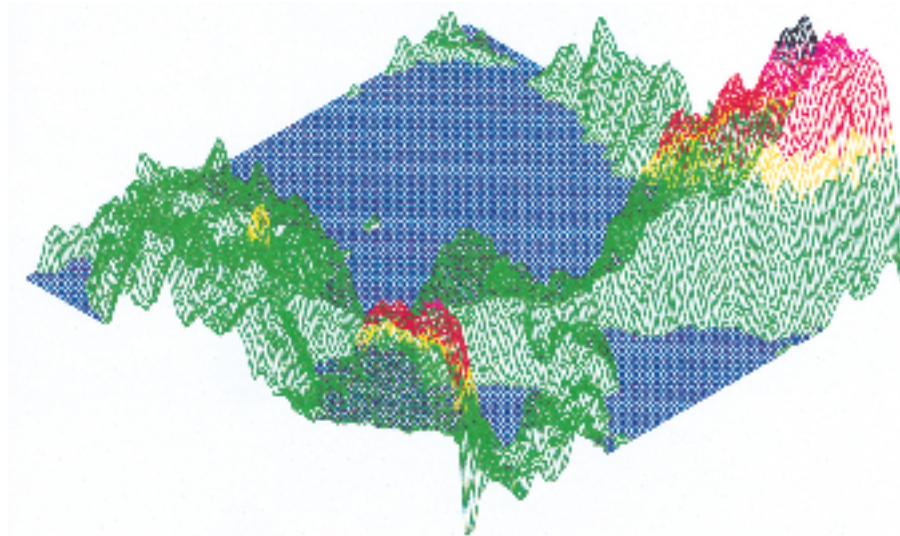
Generating a warped surface by moving a straight line so that any two consecutive positions are skewed.

viewed from orbit will have a certain level of ruggedness, caused by bays, peninsulas, and inlets. The same coastline viewed from an aircraft will show further detail, and the detail will mimic the ruggedness, with smaller bays, peninsulas, and inlets.

Mandelbrot developed the geometry of **fractals**, which is short for fractional dimensionals, to define such repetition mathematically. Fractal geometry has led to the development of computer-based fractal design tools that can produce very complex random patterns. The term fractal is used to describe graphics of randomly generated curves and surfaces that exhibit a degree of self similarity. These fractal curves and surfaces emerge in the form of images that are much more visually realistic than can be produced with conventional geometric forms (Figure 3.62). In addition, fractal image compression techniques can be used to solve storage problems associated with large graphical image files on computers.

**3.13 3-D Modeling**

Traditionally, the means of communication in the engineering design process was through paper drawings done by hand. With the availability of CAD tools, these 2-D technical drawings are produced on computer. More recently, 3-D modeling software has become available on increasingly powerful PCs and increasingly inexpensive engineering workstations (Figure 3.63). Because 3-D modeling systems create models of the product being designed, this system offers considerably more possibilities as to how it can be integrated into the design process than a 2-D CAD drawing does.

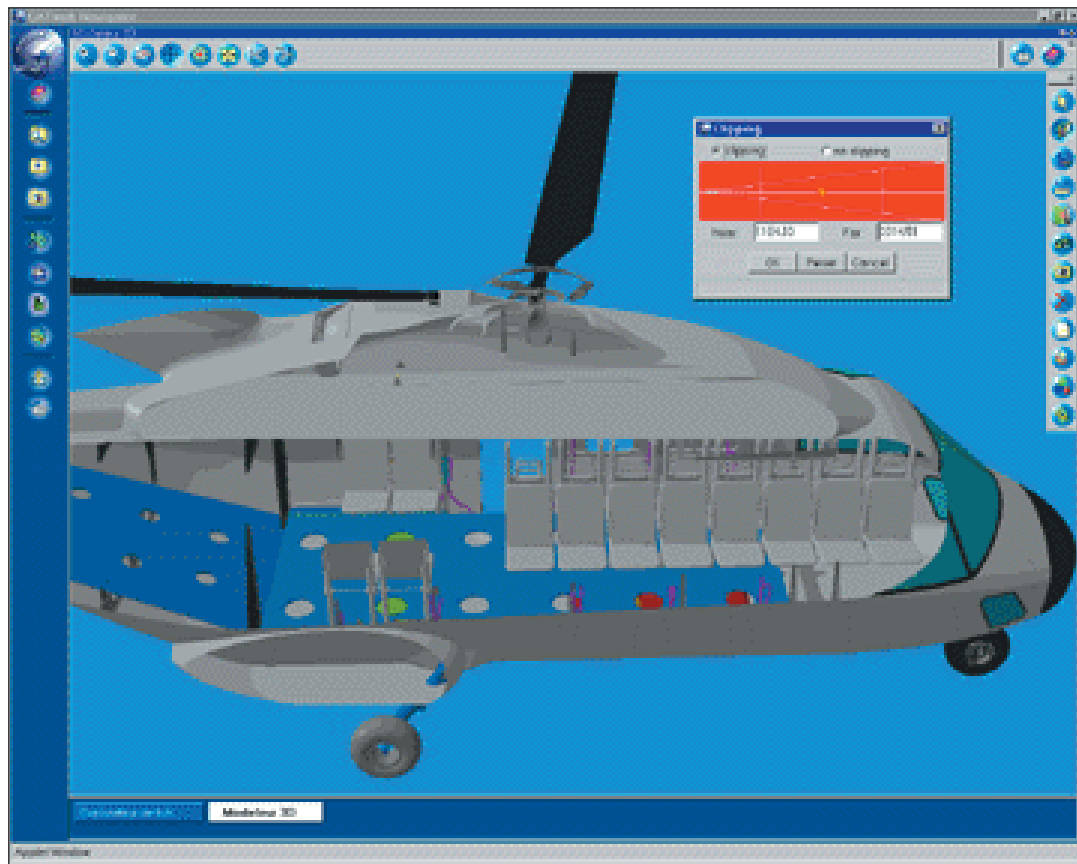


**Figure 3.62**

**Fractal surface**

Mountain terrain based on fractal surfaces.

(Courtesy of Gary Bertoline )

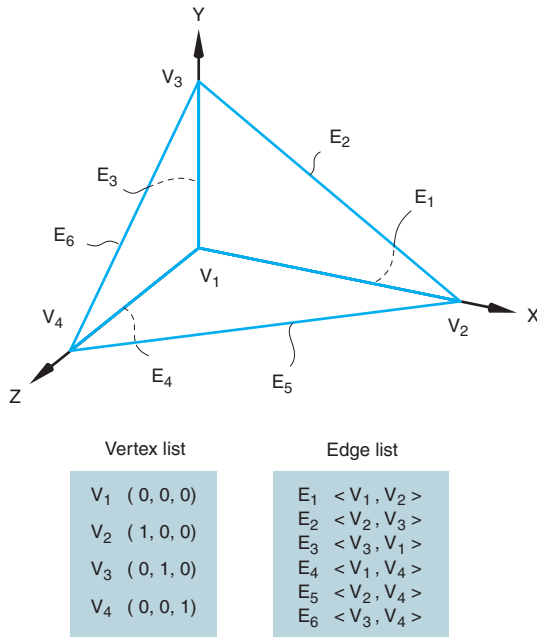


**Figure 3.63**

**3-D model**

Three-dimensional computer model of a helicopter.

(IBM Gallery Exhibitor.)



**Figure 3.64**

**Wireframe model**

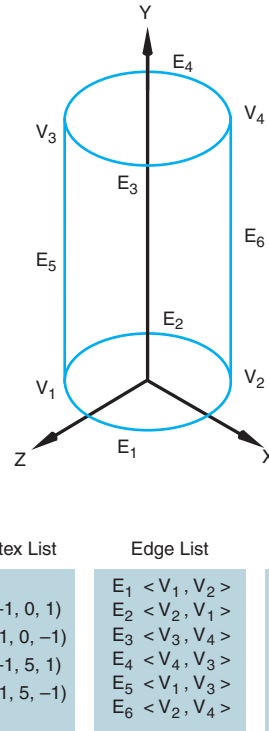
The vertex and edge list of a wireframe model.

The following section offers an overview of two common approaches for generating 3-D computer models.

**3.13.1 Wireframe Modeling**

The simplest 3-D modeler is a **wireframe modeler**. In this type of modeler, which is a natural outgrowth of 2-D CAD, two types of elements must be defined in the database: *edges* and *vertices* (Figure 3.64). For the tetrahedron in the figure, the vertex list contains the geometric information on the model. Each vertex is defined by an (X, Y, Z) coordinate, which anchors the model in space. The topology of the model is represented by the edge list. The edge list does not contain coordinate information. The location, orientation, and length of an edge must be derived indirectly, through calculations of the vertices at either end of the edge. For example, edge E1 consists of vertices V1 and V2. The coordinate locations of V1 (0,0,0) and V2 (1,0,0) indicate that E1 has a length of 1 and is oriented along the X axis.

Most wireframe modelers support curved edges, as well as straight edges. Because of the added mathematical complexity, the curved edges are usually only circular curves. An example is a cylinder, as shown in Figure 3.65.



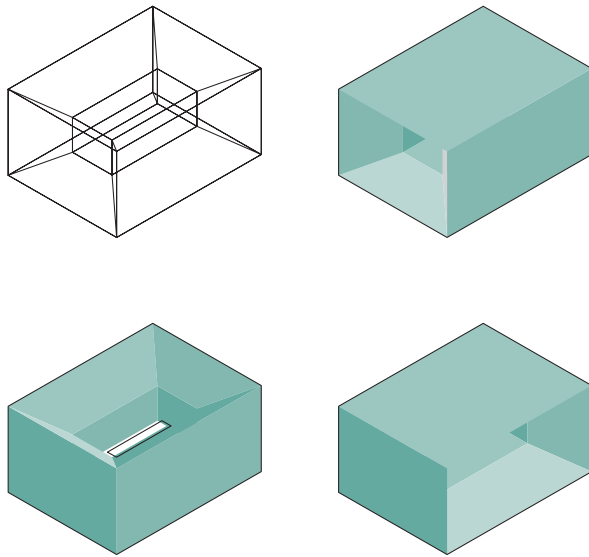
**Figure 3.65**

**A wireframe model using circular and linear edges**

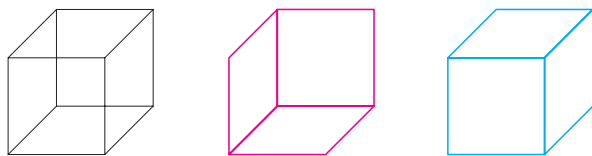
Full circles are broken into two arcs to allow them to connect to other edges.

The use of curved edges in a wireframe model reveals one of the deficiencies of a wireframe model as a representation of a 3-D object. Take the cylinder as an example. The end faces of the cylinder are represented by single, continuous, circular edges. But a cylinder has no side edges, making it difficult with a wireframe modeler to connect the top and bottom faces of the cylinder. The two linear edges (E5, E6) shown in the figure are artifacts of the wireframe model and are necessary for maintaining integrity of the database and for visualizing the model.

Wireframe models also have problems with *uniqueness*. Figure 3.66 shows a wireframe model and some of the possible objects it could represent. In the model, the lack of information about surfaces gives rise to *ambiguities* concerning the orientation of the object. The Necker cube is a classic example (Figure 3.67). Because surface information is not available, edges that would normally be hidden are not, and the orientation is unclear. Some wireframe modelers have implemented computational

**Figure 3.66****Example of a wireframe model lacking uniqueness**

The same edge and vertex list can describe different objects, depending on how the faces are interpreted.

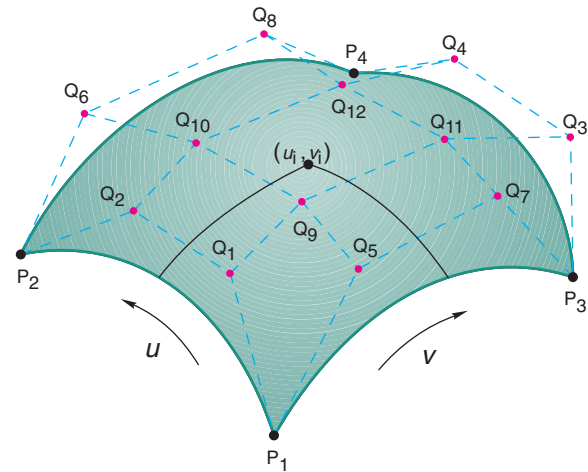
**Figure 3.67****A wireframe model with an ambiguous orientation: the Necker cube**

Which face is in front and which is in back?

routines to calculate and remove hidden edges. Since this involves calculating surface information that is not inherent in a true wireframe modeler, the process is often slow and cumbersome.

**3.13.2 Surface Modeling**

The pressures of wartime production of ships and aircraft during World War II and the expanding consumer market after the war led to the development of systems using the mathematical descriptions of curved surfaces. *Parametric techniques* popularized by Steven A. Coons were adopted

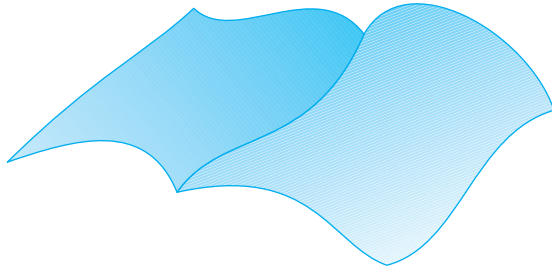
**Figure 3.68****A Bezier bicubic surface patch**

The patch consists of four connected Bezier curves and 12 control points.

as a way of precisely describing the curvature of a surface in all three dimensions. **Surface models** define the surface features, as well as the edges, of objects.

Different types of spline curves are used to create surface patches with different modeling characteristics. For example, the advantage of Bezier surface patches is that they are easy-to-sculpt natural surfaces (Figure 3.68). The control points are an intuitive tool with which the user can work. There are, however, two disadvantages to Bezier patches. First, they do not provide *local control*; a change in one control point affects the shape of the whole patch, and could alter the edge connecting two patches together. Figure 3.69 shows an example of two patches that are connected (there is no gap between them), but without the level of **continuity** necessary to create a smooth surface. The second disadvantage is that it is hard to calculate control points that will allow the patch to pass through already-existing points in a model, which means it is not possible to control the exact location of the patch. This reduces the precision of the model.

In contrast, B-spline patches allow local control; moving one control point does not affect the whole surface. With B-splines, it is much easier to create surfaces through predefined points or curves. NURBS surfaces use *rational B-splines*, which include a *weighting* value at each point on the surface. The weighting value allows some points to have more influence over the shape of the curve than other points. This means that a wider variety of

**Figure 3.69****Two discontinuous surface patches**

The crease between the surface patches reveals the discontinuity.

curved surfaces are possible than with regular B-splines. Because NURBS surfaces can also precisely describe conic surfaces, they are gaining popularity in many tasks previously handled by other types of 3-D modelers.

One general weakness of surface modelers is their inability to handle *topology*. For example, if you have a series of patches that form a closed-volume model and you “drill a hole” in the model, you will pass through an infinitely thin surface into a void, for which no information is available. To handle this situation, the user or the

system must *cover over* the inside of the hole. Some surface modelers simply do not have the flexibility to make this sort of topological modification easily.

As mentioned earlier, there are times when surface modeling systems are invaluable. Precise, mathematically defined curved surfaces are a must in the aerospace, automotive, and shipbuilding industries. In many cases, information about the surface of the object is the most critical element in manufacturing the product, and the surface information used in the model can often be used directly by analysis and manufacturing software tools.

### 3.14 Summary

This chapter introduces you to the geometry commonly used in engineering design graphics. Since surface modeling is an important part of modern engineering design, modern techniques and geometric forms used with CAD systems are described. In addition, geometric construction techniques useful in creating some types of 2-D engineering geometry are included. Because geometry provides the building blocks for creating and representing more complex products and structures, the information presented in this chapter will be used throughout the remaining chapters in this text.

### Goals Review

Now that you have completed this chapter, you should be able to accomplish the goals listed below. If you need further review, you can refer to the chapter section numbers shown with each goal.

1. Describe the importance of engineering geometry in the design process. Objectives and Overview
2. Describe coordinate geometry and coordinate systems and apply them to CAD. Section 3.3
3. Explain the right-hand rule. Section 3.3.1
4. List the major categories of geometric entities. Section 3.4
5. Explain and construct the geometric conditions that occur between lines. Section 3.5.2 Lines
6. Explain and construct tangent conditions between lines and curves. Section 3.5.3
7. Explain and construct conic sections, roulettes, double-curved lines, and freeform curves. Sections 3.6, 3.7, 3.8, and 3.9
8. List and describe surface geometric forms. Section 3.12
9. Describe engineering applications of geometry. Sections 3.6.1 and 3.6.2
10. Describe two types of 3-D modeling. Section 3.13

### Questions for Review

1. Define engineering geometry and describe its importance to engineering design.
2. Describe how coordinate space relates to engineering design.
3. Explain the right-hand rule, using sketches.
4. How is a curved line different from a straight line?
5. Describe an engineering application for a parabola and for a hyperbola.
6. What is the difference between a plane and a surface?
7. List six quadrilaterals.
8. Define concentric circles.

## 3-D Modeling Project

### Chapter 3: Stapler Modeling Project

All sketches of each part of the stapler should be completed along with a parts list. The plastic housing that encloses the metal parts that actually do the stapling are quite complex giving the stapler both aesthetic and functional design elements. Redesign the plastic housing so that the stapler is not

only aesthetically pleasing but has improved functionality by allowing the stapler to stand on its hinged end in addition to its current flat base. Create design sketches of your new design ideas; then refine the design you select through more refined sketches.

9. Define a tangent.
10. Describe an engineering application for an ellipse.
11. List and sketch four conic sections.
12. List and sketch four regular polyhedrons.
13. List and sketch four polygonal prisms.
14. Define a warped surface.
15. List the major categories of geometric forms.
16. Sketch and label the various conditions that can occur between two lines.
17. Sketch and label the various tangent conditions that can occur between lines and curves and between two curves.
18. Sketch a circle and label the important parts.
19. List and define freeform curves.
20. Describe fractals.
21. What is the minimum information needed to define a true wireframe model? Is there enough information in a wireframe model to determine which edges are hidden?
22. What are the advantages and disadvantages of the three types of curves used to make surface patches?

### Further Reading

Anand, V. B. *Computer Graphics and Geometric Modeling for Engineers*. New York: Wiley, 1993.

Barnsley, M. *Fractals Everywhere*. Boston, MA: Academic Press Inc., 1988.

DeJong, P. E., J. S. Rising, and M. W. Almfeldt. *Engineering Graphics Communications, Analysis, Creative Design*. 6th ed. Dubuque, IA: Kendall/Hunt Publishing Company, 1983.

Foley, J. D., A. VanDamm, S. K. Feiner, and J. K. Hughes. *Computer Graphics Principles and Practices*. 2d ed. Reading, MA: Addison-Wesley, 1991.

Mandlebrot, B. *The Fractal Geometry of Nature*. New York: Freeman, 1983.

Mortenson, M. E. *Geometric Modeling*. New York: Wiley, 1985.

Rogers, D. F., and J. A. Adams. *Mathematical Elements for Computer Graphics*. 2d ed. New York: McGraw-Hill, 1990.

Wellman, B. L. *Technical Descriptive Geometry*. 2d ed. New York: McGraw-Hill, 1987.

Whitt, L. "The Standup Conic Presents: The Parabola and Applications." *The UMAP Journal* 3, no. 3 (1982), pp. 285–313.

Whitt, L. "The Standup Conic Presents: The Hyperbola and Applications." *The UMAP Journal* 5, no. 1 (1984).



## Problems

The CD-ROM contains starter files for most of the drawing problems in either your native CAD file format or as a DXF file which can be imported into most CAD software programs. If sketching the problems, use either paper recommended by your instructor or the workbook that accompanies this text.

**3.1** Using rectangular graph paper, draw or sketch the X and Y axes for the Cartesian coordinate system, then locate point A at 2,3; point B at -2,5; point C at -3,-2; and point D at 4,-1.

**3.2** Using the same axes constructed in Problem 4.1, construct line AB using endpoints -1,-2 and -3,-4.

**3.3** Add to the axes in Problem 3.1 a line MN with the first endpoint at 1,1 and the second endpoint at 45 degrees and 1" from the first endpoint.

**3.4** Using rectangular graph paper, construct the X and Y axes, then draw a figure, using the following absolute coordinate values:

0,0  
3,0  
3,2  
0,2  
0,0

**3.5** Using rectangular graph paper, construct the X and Y axes, then draw a figure, using the following relative coordinate values:

0,0  
4,0  
0,3  
-4,0  
0,-3

**3.6** Using isometric grid paper, construct the X, Y, and Z axes. Reference Figure 3.4. Using the right-hand rule, place points at the following locations:

1. 0,0,0  
2. 4,0,0  
3. 4,2,0  
4. 0,2,0  
5. 0,0,2  
6. 4,0,2  
7. 4,2,2  
8. 0,2,2

Connect points 1-2, 2-3, 3-4, 4-1.

Connect points 5-6, 6-7, 7-8, 8-5.

Connect points 4-8, 3-7, 1-5, 2-6.

What geometric solid is produced?

**3.7** (Figure 3.70) Draw the ratchet and detent, using the given dimensions.

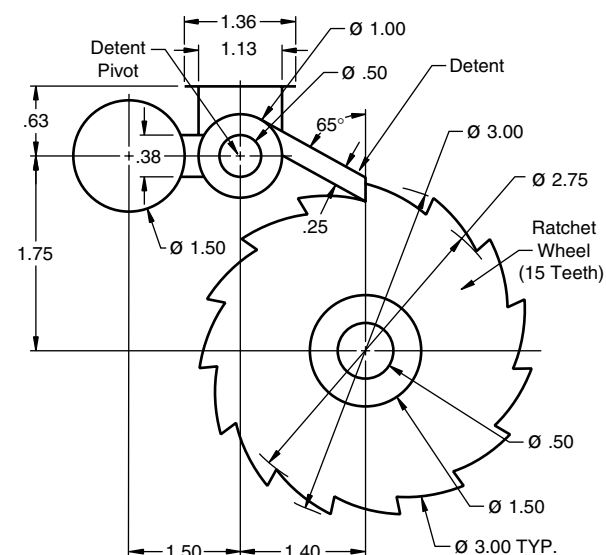
**3.8** (Figure 3.71) A Geneva stop mechanism has a driving wheel that turns at a constant speed and a driven wheel that turns intermittently. The driven wheel rotates one-fourth turn every time the drive pin enters and leaves a slot. Begin the drawing by constructing triangle ABC, then locate point P and center line CP. After the drawing is complete, measure angle X.

**3.9** (Figure 3.72) The piston is driven by the connecting rod, which rotates on the crankshaft. As point A moves in a circular path from A0 to A12, the piston pin B moves in a straight line from points B0 to B12. Create a displacement curve by dividing the semicircles into 12 equal parts, then locate point B at each of the 12 intervals, and finally transfer that displacement to the diagram.

**3.10** Create an A-size drawing sheet, then construct a helix from a right circular cylinder that has a 2" diameter base and is 4" high.

**3.11** (Figure 3.73) Draw the cam arm, using the given dimensions and calculating the missing ones. The curve is made of five tangent circular arcs. The rise is the change in distance from the center of the hole in the cam arm.

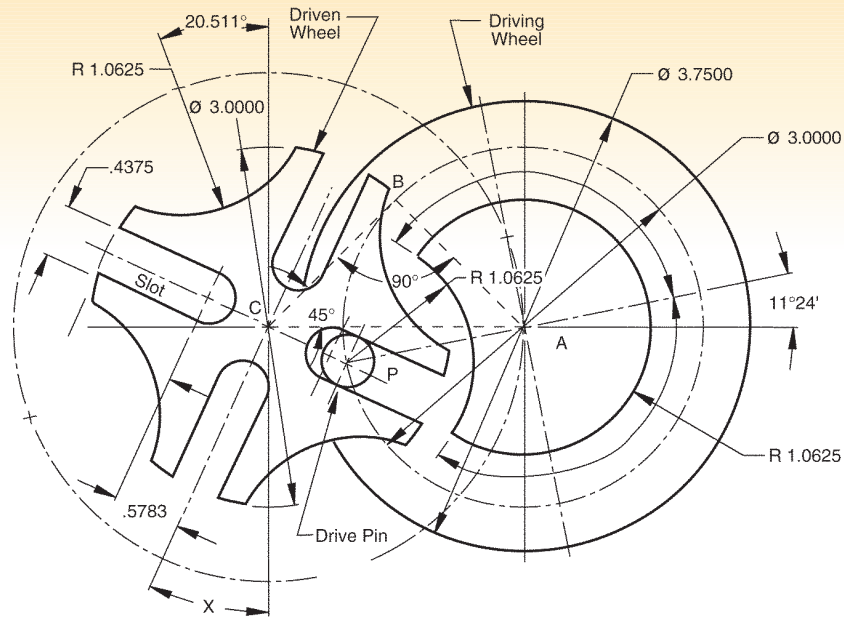
**3.12** (Figure 3.74) Draw the slip cover, using the given dimensions.



**Figure 3.70**

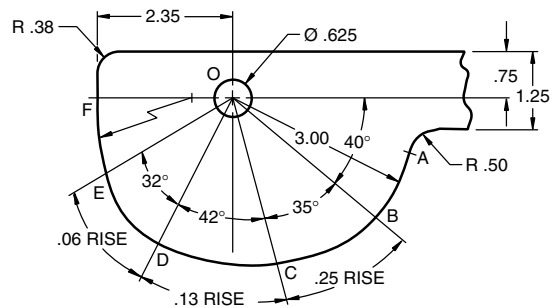
Ratchet and detent





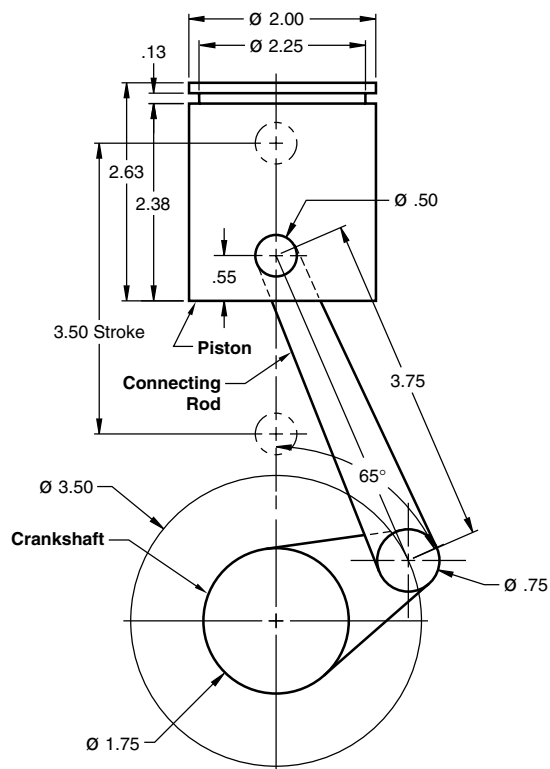
**Figure 3.71**

Geneva stop mechanism



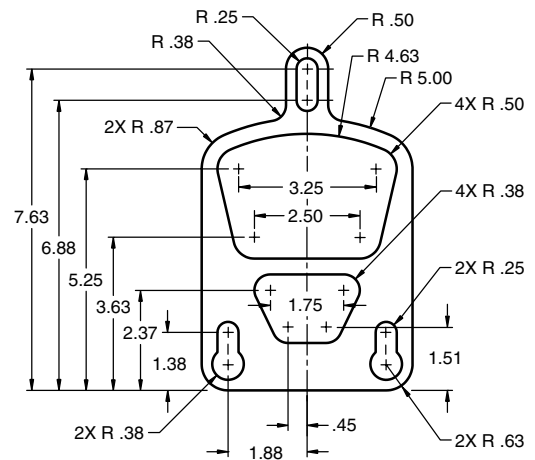
**Figure 3.73**

Cam arm



**Figure 3.72**

Piston, connecting rod, crankshaft, and displacement curve



**Figure 3.74**

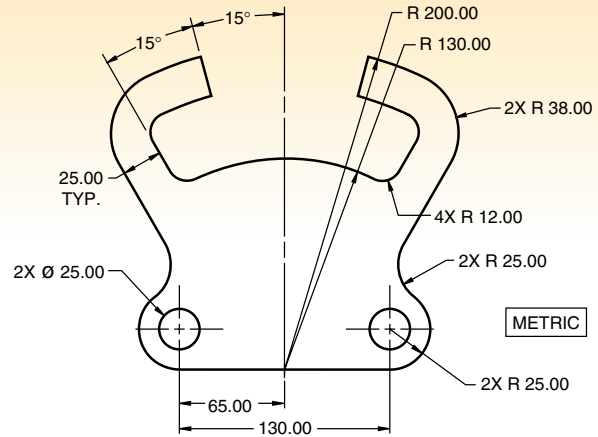
Slip cover

**3.13** (Figures 3.75 through 3.84) Draw the part, using the given dimensions.

**3.14** (Figure 3.85) Create wireframe or solid models by sweeping the profiles shown in the figure using a scale assigned by your instructor.

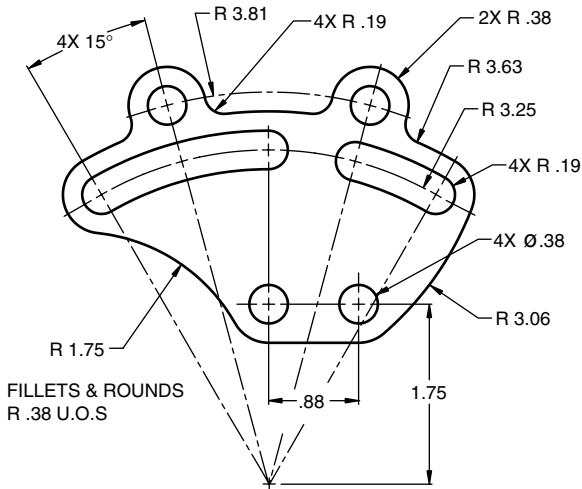
Do the following with each of the profiles:

- Sweep linearly 5 units along the +Z axis.
- Sweep linearly along the vector (2,-3,5).
- Sweep 360° about the Y axis.
- Sweep 360° about the X axis.
- Sweep 90° about the +X axis.



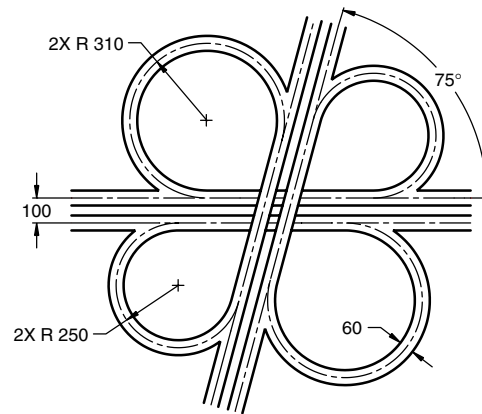
**Figure 3.75**

Split guide



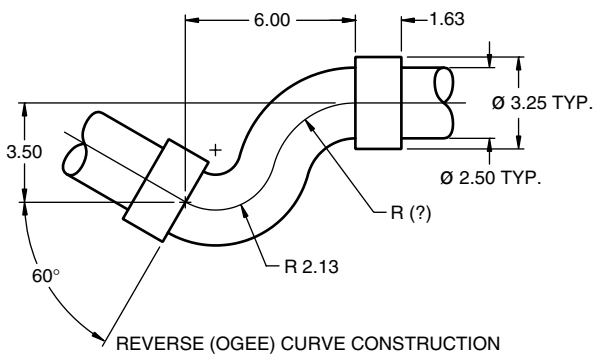
**Figure 3.76**

Arched follower



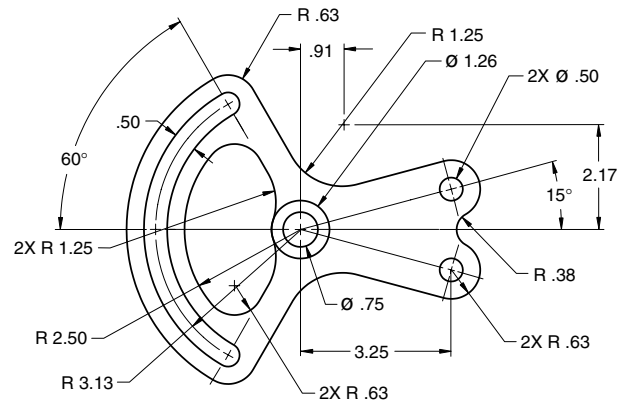
**Figure 3.77**

Highway interchange



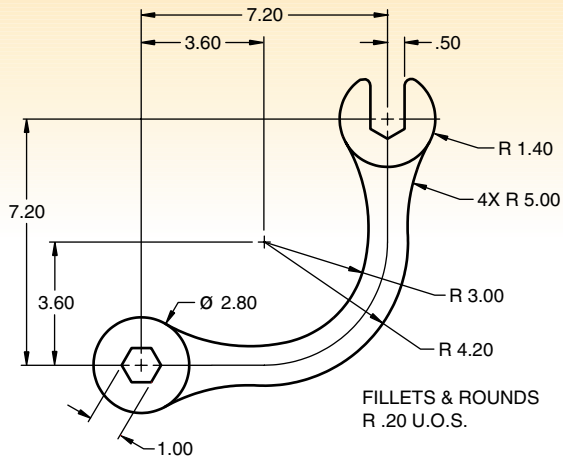
**Figure 3.78**

Offset pipe

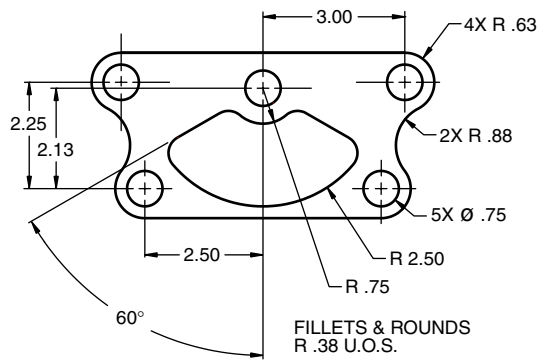


**Figure 3.79**

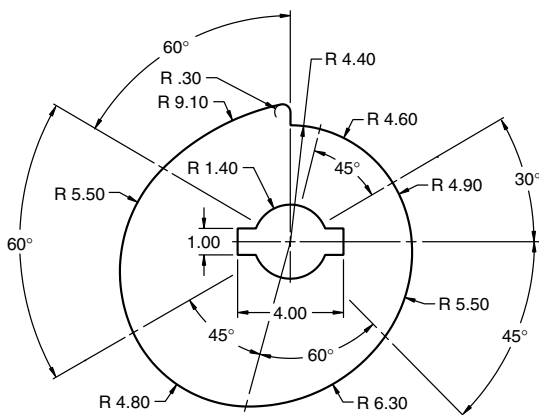
Butterfly spacer



**Figure 3.80**  
Offset wrench

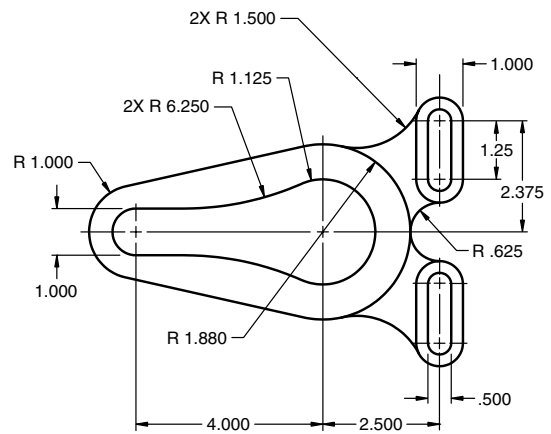


**Figure 3.81**  
Centering plate

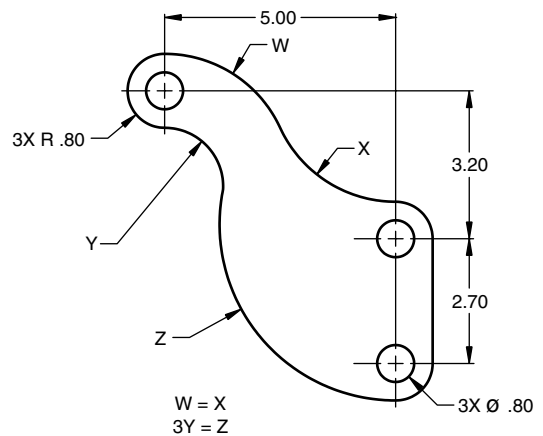


**Figure 3.83**  
Variable guide

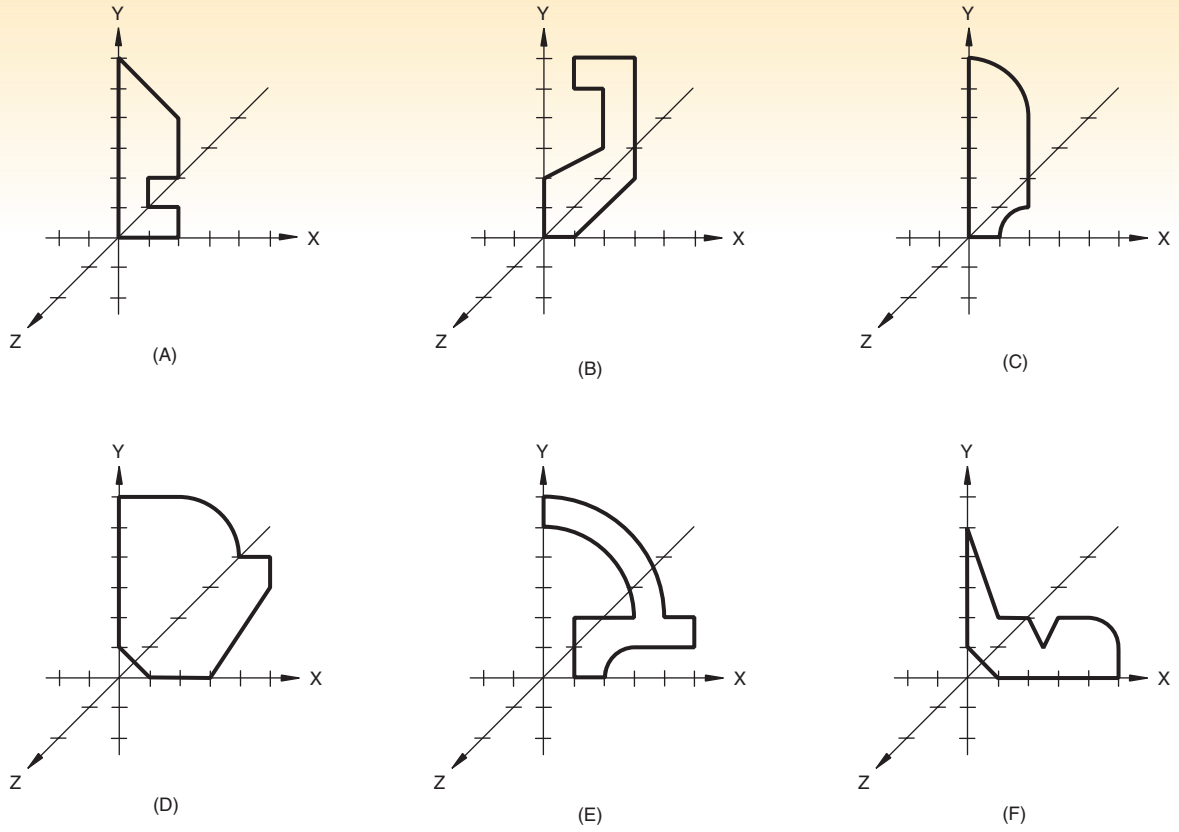
- f. Sweep  $270^\circ$  about the  $-Y$  axis.
- g. Sweep  $360^\circ$  about a  $Y$  axis offset 2 units in  $+X$  direction.
- h. Sweep  $180^\circ$  about an  $X$  axis offset 3 units in  $+Y$  direction.
- i. Sweep the profile about 2 different axes to create two objects. Combine the two objects to create a new single object.



**Figure 3.82**  
Harness guide



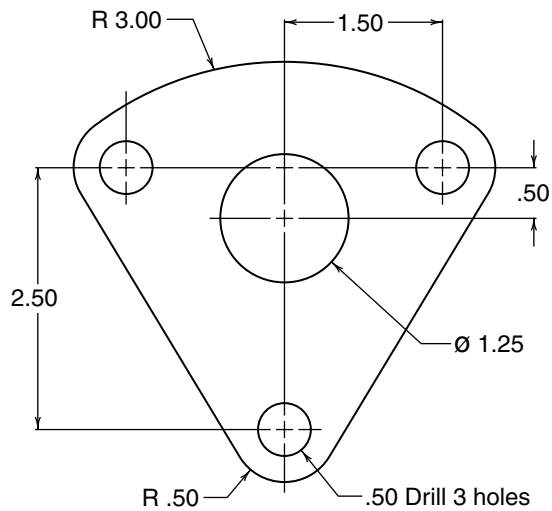
**Figure 3.84**  
Transition



**Figure 3.85**  
Profiles to be swept

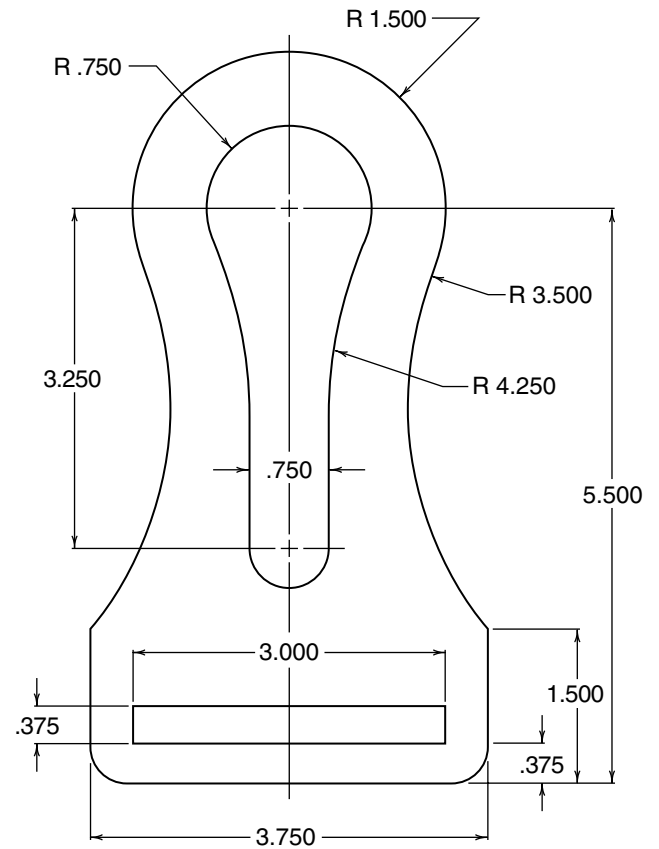
## Classic Problems

The following classic problems were taken from *Engineering Drawing & Graphic Technology*, 14th Edition, by Thomas E. French, Charles J. Vierck, and Robert Foster. All fillets and rounds 0.125 inches or 2 mm unless otherwise indicated. Sketch or draw with CAD the 2-D drawing of the problems shown in the figures.



**Figure 3.86**

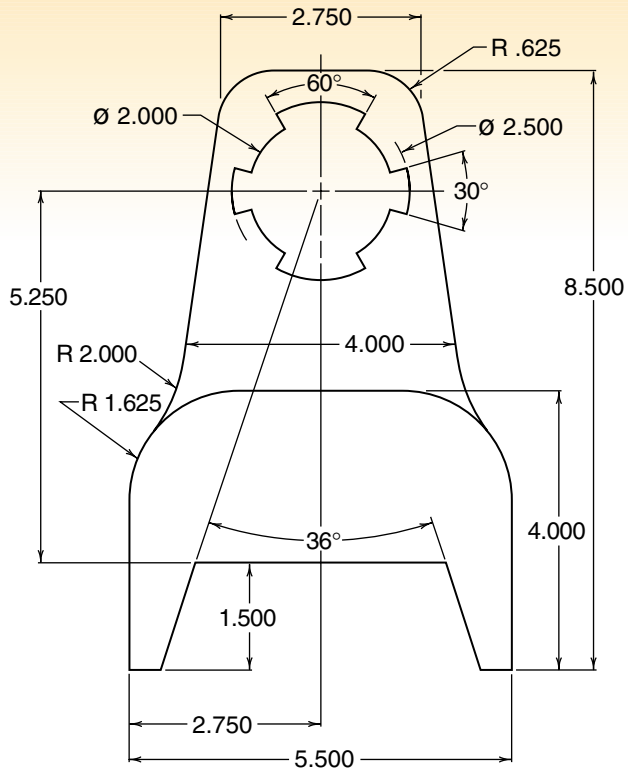
Rod guide



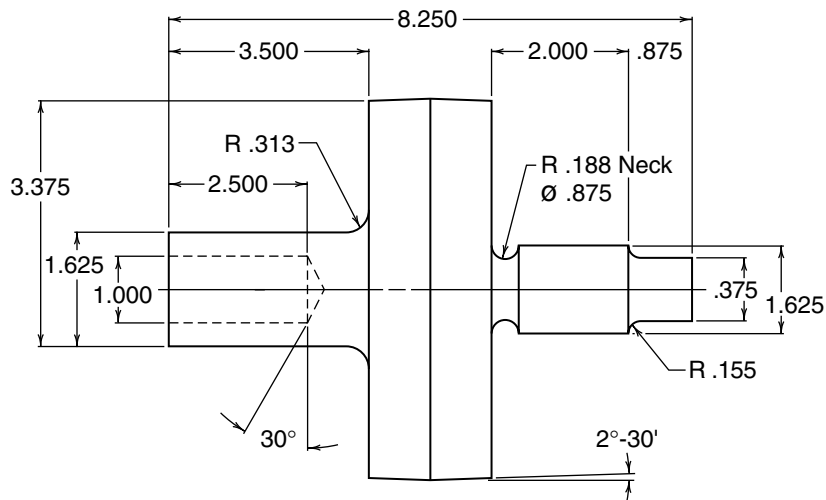
**Figure 3.87**

Eyelet

1. Rod guide Fig. 3.86
2. Eyelet Fig. 3.87
3. Spline lock Fig. 3.88
4. Pulley shaft Fig. 3.89



**Figure 3.88**  
Spline lock



**Figure 3.89**  
Pulley shaft