

CHAPTER

16

HEATING AND COOLING OF BUILDINGS

The houses in the past were built to keep the rain, snow, and thieves out with hardly any attention given to heat losses and *energy conservation*. Houses had little or no insulation, and the structures had numerous cracks through which air leaked. We have seen dramatic changes in the construction of residential and commercial buildings in the 20th century as a result of increased awareness of limited energy resources together with the escalating energy prices and the demand for a higher level of thermal comfort. Today, most local codes specify the minimum level of insulation to be used in the walls and the roof of new houses, and often require the use of double-pane windows. As a result, today's houses are well insulated, weatherproofed, and nearly air tight, and provide better thermal comfort.

The failures and successes of the past often shed light to the future, and thus we start this chapter with a *brief history* of heating and cooling to put things into historical perspective. Then we discuss the criteria for *thermal comfort*, which is the primary reason for installing heating and cooling systems. In the remainder of the chapter, we present calculation procedures for the *heating and cooling loads* of buildings using the most recent information and design criteria established by the American Society of Heating, Refrigerating and Air-Conditioning Engineers, Inc. (ASHRAE), which publishes and periodically revises the most authoritative handbooks in the field. This chapter is intended to introduce the readers to an exciting application area of heat transfer, and to help them develop a deeper understanding of the fundamentals of heat transfer using this familiar setup. The reader is referred to ASHRAE handbooks for more information.

CONTENTS

- 16-1 A Brief History 16-2
- 16-2 Human Body and Thermal Comfort 16-3
- 16-3 Heat Transfer from the Human Body 16-8
- 16-4 Design Conditions for Heating and Cooling 16-12
- 16-5 Heat Gain from People, Lights, and Appliances 16-21
- 16-6 Heat Transfer through Walls and Roofs 16-26
- 16-7 Heat Loss from Basement Walls and Floors 16-36
- 16-8 Heat Transfer through Windows 16-42
- 16-9 Solar Heat Gain through Windows 16-52
- 16-10 Infiltration Heat Load and Weatherizing 16-59
- 16-11 Annual Energy Consumption 16-63
- Summary* 16-69
- References and Suggested Reading* 16-71
- Problems* 16-71

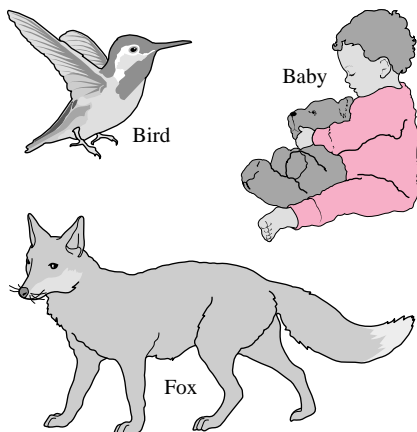

FIGURE 16-1

Most animals come into this world with built-in insulation, but human beings come with a delicate skin.

16-1 ■ A BRIEF HISTORY

Unlike animals such as a fox or a bear that are born with built-in furs, human beings come into this world with little protection against the harsh environmental conditions (Fig. 16-1). Therefore, we can claim that the search for thermal comfort dates back to the beginning of human history. It is believed that early human beings lived in caves that provided shelter as well as protection from extreme thermal conditions. Probably the first form of heating system used was *open fire*, followed by fire in dwellings through the use of a *chimney* to vent out the combustion gases. The concept of *central heating* dates back to the times of the Romans, who heated homes by utilizing double-floor construction techniques and passing the fire's fumes through the opening between the two floor layers. The Romans were also the first to use *transparent windows* made of mica or glass to keep the wind and rain out while letting the light in. Wood and coal were the primary energy sources for heating, and oil and candles were used for lighting. The ruins of south-facing houses indicate that the value of *solar heating* was recognized early in the history.

The development of the first *steam heating* system by James Watt dates back to 1770. When the American Society of Heating and Ventilating Engineers was established in New York in 1894, central heating systems using cast iron warm air furnaces and boilers were in common use. *Fans* were added in 1899 to move the air mechanically, and later *automatic firing* replaced the manual firing. The steam heating systems gained widespread acceptance in the early 1900s by the introduction of fluid-operated *thermostatic traps* to improve the fluid circulation. Gravity-driven hot water heating systems were developed in parallel with steam systems. Suspended and floor-type unit heaters, unit ventilators, and panel heaters were developed in the 1920s. *Unit heaters* and *panel heaters* usually used steam, hot water, or electricity as the heat source. It became common practice to conceal the radiators in the 1930s, and the *baseboard radiator* was developed in 1944. Today, air heating systems with a duct distribution network dominate the residential and commercial buildings.

The development of *cooling systems* took the back seat in the history of thermal comfort since there was no quick way of creating "coolness." Therefore, early attempts at cooling were passive measures such as blocking off direct sunlight and using thick stone walls to store coolness at night. A more sophisticated approach was to take advantage of *evaporative cooling* by running water through the structure, as done in the Alhambra castle. Of course, natural *ice* and *snow* served as "cold storage" mediums and provided some cooling.

In 1775, Dr. William Cullen made *ice* in Scotland by evacuating the air in a water tank (Fig. 16-2). It was also known at those times that some chemicals lowered temperatures. For example, the temperature of snow can be dropped to -33°C by mixing it with calcium chloride. This process was commonly used to make ice cream. In 1851, Ferdinand Carre designed the first *ammonia absorption refrigeration system*, while Dr. John Gorrie received a patent for an *open air refrigeration cycle* to produce ice and refrigerated air. In 1853, Alexander Twining of Connecticut produced 726 kg of ice a day using sulfuric ether as the refrigerant. In 1872, David Boyle developed an ammonia compression machine that produced ice. Mechanical refrigeration at those times was used primarily to make ice and preserve perishable commodities such as meat and fish (Sauer and Howell, 1994).

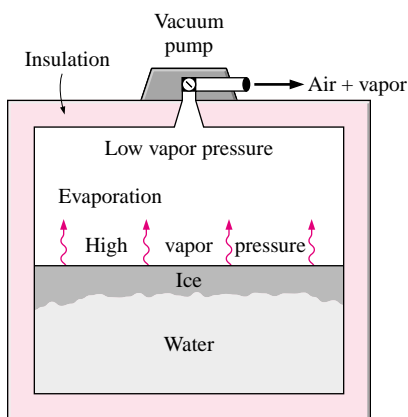

FIGURE 16-2

In 1775, ice was made by evacuating the air in a water tank.

Comfort cooling was obtained by ice or by chillers that used ice. *Air cooling systems* for thermal comfort were built in the 1890s, but they did not find widespread use until the development of mechanical refrigeration in the early 1900s. In 1905, 200 Btu/min (or 211 kJ/min) was established as **1 ton of refrigeration**, and in 1902 a 400-ton air-conditioning system was installed in the New York Stock Exchange. The system operated reliably for 20 years. A modern air-conditioning system was installed in the Boston Floating Hospital in 1908, which was a first for a hospital. In a monumental paper presented in 1911, Willis Carrier (1876–1950), known as the “Father of Air Conditioning,” laid out the formulas related to the dry-bulb, wet-bulb, and dew-point temperatures of air and the sensible, latent, and total heat loads. By 1922, the centrifugal refrigeration machine developed by Carrier made water chilling for medium and large commercial and industrial facilities practical and economical. In 1928 the Milan Building in San Antonio, Texas, was the first commercial building designed with and built for comfort air-conditioning specifications (Sauer and Howell, 1994).

Frigidaire introduced the first *room air conditioner* in the late 1920s (Fig. 16–3). The halocarbon refrigerants such as Freon-12 were developed in 1930. The concept of a *heat pump* was described by Sadi Carnot in 1824, and the operation of such a device called the “heat multiplier” was first described by William Thomson (Lord Kelvin) in 1852. T. G. N. Haldane built an experimental heat pump in 1930, and a heat pump was marketed by De La Vargne in 1933. General Electric introduced the heat pump in the mid 1930s, and heat pumps were being mass produced in 1952. *Central air-conditioning systems* were being installed routinely in the 1960s. The oil crises of the 1970s sent shock waves among the consumers and the producers of energy-consuming equipment, which had taken energy for granted, and brought about a renewed interest in the development of energy-efficient systems and more effective insulation materials. Today most residential and commercial buildings are equipped with modern air-conditioning systems that can heat, cool, humidify, dehumidify, clean, and even deodorize the air—in other words, *condition* the air to people’s desires.

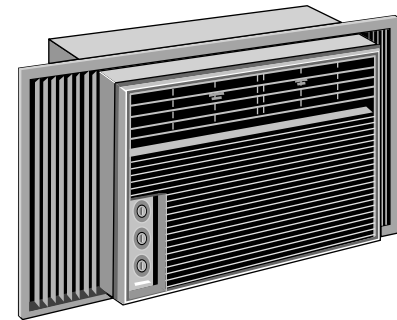

FIGURE 16–3

The first room air conditioner was introduced by Frigidaire in the late 1920s.

16–2 ■ HUMAN BODY AND THERMAL COMFORT

The term **air-conditioning** is usually used in a restricted sense to imply cooling, but in its broad sense it means *to condition* the air to the desired level by heating, cooling, humidifying, dehumidifying, cleaning, and deodorizing. The purpose of the air-conditioning system of a building is to provide *complete thermal comfort* for its occupants. Therefore, we need to understand the thermal aspects of the *human body* in order to design an effective air-conditioning system.

The building blocks of living organisms are *cells*, which resemble miniature factories performing various functions necessary for the survival of organisms. The human body contains about 100 trillion cells with an average diameter of 0.01 mm. In a typical cell, thousands of chemical reactions occur every second during which some molecules are broken down and energy is released and some new molecules are formed. The high level of chemical activity in the cells that maintain the human body temperature at a temperature of 37.0°C while performing the necessary bodily functions is called the **metabolism**. In simple terms, metabolism refers to the burning of foods such as carbohydrates, fat, and protein. The metabolizable energy content of foods is usually

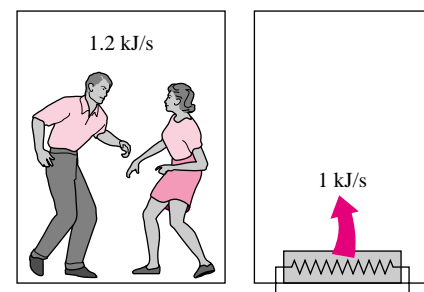

FIGURE 16–4

Two fast-dancing people supply more heat to a room than a 1-kW resistance heater.

TABLE 16-1

Metabolic rates during various activities (from ASHRAE Handbook of Fundamentals, Chap. 8, Table 4)

Activity	Metabolic rate*, W/m ²
Resting:	
Sleeping	40
Reclining	45
Seated, quiet	60
Standing, relaxed	70
Walking (on the level):	
2 mph (0.89 m/s)	115
3 mph (1.34 m/s)	150
4 mph (1.79 m/s)	220
Office Activities:	
Reading, seated	55
Writing	60
Typing	65
Filing, seated	70
Filing, standing	80
Walking about	100
Lifting/packing	120
Driving/Flying:	
Car	60–115
Aircraft, routine	70
Heavy vehicle	185
Miscellaneous Occupational Activities:	
Cooking	95–115
Cleaning house	115–140
Machine work:	
Light	115–140
Heavy	235
Handling 50-kg bags	235
Pick and shovel work	235–280
Miscellaneous Leisure Activities:	
Dancing, social	140–255
Calisthenics/exercise	175–235
Tennis, singles	210–270
Basketball	290–440
Wrestling, competitive	410–505

*Multiply by 1.8 m² to obtain metabolic rates for an average man.

expressed by nutritionists in terms of the capitalized Calorie. One Calorie is equivalent to 1 Cal = 1 kcal = 4.1868 kJ.

The rate of metabolism at the resting state is called the *basal metabolic rate*, which is the rate of metabolism required to keep a body performing the necessary bodily functions such as breathing and blood circulation at zero external activity level. The metabolic rate can also be interpreted as the energy consumption rate for a body. For an *average man* (30 years old, 70 kg, 1.73 m high, 1.8 m² surface area), the basal metabolic rate is 84 W. That is, the body is converting chemical energy of the food (or of the body fat if the person had not eaten) into heat at a rate of 84 J/s, which is then dissipated to the surroundings. The metabolic rate increases with the *level of activity*, and it may exceed 10 times the basal metabolic rate when someone is doing strenuous exercise. That is, two people doing heavy exercising in a room may be supplying more energy to the room than a 1-kW resistance heater (Fig. 16-4). An average man generates heat at a rate of 108 W while reading, writing, typing, or listening to a lecture in a classroom in a seated position. The maximum metabolic rate of an average man is 1250 W at age 20 and 730 at age 70. The corresponding rates for women are about 30 percent lower. Maximum metabolic rates of trained athletes can exceed 2000 W.

Metabolic rates during various activities are given in Table 16-1 per unit body surface area. The **surface area** of a nude body was given by D. DuBois in 1916 as

$$A_s = 0.202m^{0.425}h^{0.725} \quad (\text{m}^2) \quad (16-1)$$

where m is the mass of the body in kg and h is the height in m. *Clothing* increases the exposed surface area of a person by up to about 50 percent. The metabolic rates given in the table are sufficiently accurate for most purposes, but there is considerable uncertainty at high activity levels. More accurate values can be determined by measuring the rate of respiratory *oxygen consumption*, which ranges from about 0.25 L/min for an average resting man to more than 2 L/min during extremely heavy work. The entire energy released during metabolism can be assumed to be released as *heat* (in sensible or latent forms) since the external mechanical work done by the muscles is very small. Besides, the work done during most activities such as walking or riding an exercise bicycle is eventually converted to heat through friction.

The comfort of the human body depends primarily on three environmental factors: the temperature, relative humidity, and air motion. The temperature of the environment is the single most important index of comfort. Extensive research is done on human subjects to determine the “**thermal comfort zone**” and to identify the conditions under which the body feels comfortable in an environment. It has been observed that most normally clothed people resting or doing light work feel comfortable in the *operative temperature* (roughly, the average temperature of air and surrounding surfaces) range of 23 to 27°C (Fig. 16-5). For unclothed people, this range is 29 to 31°C. Relative humidity also has a considerable effect on comfort since it is a measure of air’s ability to absorb moisture and thus it affects the amount of heat a body can dissipate by evaporation. High relative humidity slows down heat rejection by evaporation, especially at high temperatures, and low relative humidity speeds it up. The desirable level of *relative humidity* is the broad range of 30 to 70 percent, with 50 percent being the most desirable level.

Most people at these conditions feel neither hot nor cold, and the body does not need to activate any of the defense mechanisms to maintain the normal body temperature (Fig. 16-6).

Another factor that has a major effect on thermal comfort is **excessive air motion** or **draft**, which causes undesired local cooling of the human body. Draft is identified by many as a most annoying factor in work places, automobiles, and airplanes. Experiencing discomfort by draft is most common among people wearing indoor clothing and doing light sedentary work, and least common among people with high activity levels. The air velocity should be kept below 9 m/min in winter and 15 m/min in summer to minimize discomfort by draft, especially when the air is cool. A low level of air motion is desirable as it removes the warm, moist air that builds around the body and replaces it with fresh air. Therefore, air motion should be strong enough to remove heat and moisture from the vicinity of the body, but gentle enough to be unnoticed. High speed air motion causes discomfort outdoors as well. For example, an environment at 10°C with 48 km/h winds feels as cold as an environment at -7°C with 3 km/h winds because of the chilling effect of the air motion (the wind-chill factor).

A comfort system should provide *uniform conditions* throughout the living space to avoid discomfort caused by nonuniformities such as *drafts*, *asymmetric thermal radiation*, *hot or cold floors*, and *vertical temperature stratification*. **Asymmetric thermal radiation** is caused by the *cold surfaces* of large windows, uninsulated walls, or cold products and the *warm surfaces* of gas or electric radiant heating panels on the walls or ceiling, solar-heated masonry walls or ceilings, and warm machinery. Asymmetric radiation causes discomfort by exposing different sides of the body to surfaces at different temperatures and thus to different heat loss or gain by radiation. A person whose left side is exposed to a cold window, for example, will feel like heat is being drained from that side of his or her body (Fig. 16-7). For thermal comfort, the radiant temperature asymmetry should not exceed 5°C in the vertical direction and 10°C in the horizontal direction. The unpleasant effect of radiation asymmetry can be minimized by properly sizing and installing heating panels, using double-pane windows, and providing generous insulation at the walls and the roof.

Direct contact with **cold** or **hot floor surfaces** also causes localized discomfort in the feet. The temperature of the floor depends on the way it is *constructed* (being directly on the ground or on top of a heated room, being made of wood or concrete, the use of insulation, etc.) as well as the *floor covering used* such as pads, carpets, rugs, and linoleum. A floor temperature of 23 to 25°C is found to be comfortable to most people. The floor asymmetry loses its significance for people with footwear. An effective and economical way of raising the floor temperature is to use radiant heating panels instead of turning the thermostat up. Another nonuniform condition that causes discomfort is **temperature stratification** in a room that exposes the head and the feet to different temperatures. For thermal comfort, the temperature difference between the head and foot levels should not exceed 3°C. This effect can be minimized by using destratification fans.

It should be noted that no thermal environment will please everyone. No matter what we do, some people will express some discomfort. The thermal comfort zone is based on a 90 percent acceptance rate. That is, an environment

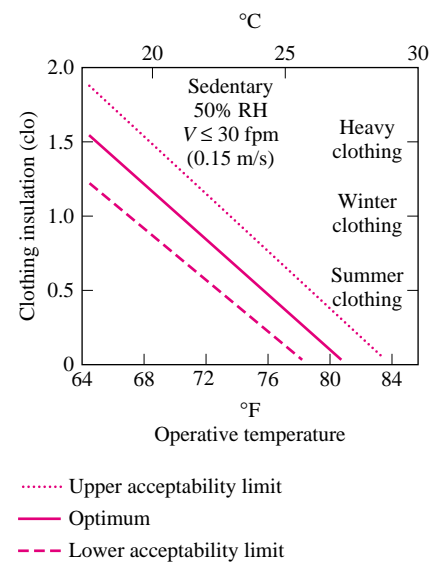

FIGURE 16-5

The effect of clothing on the environment temperature that feels comfortable (1 clo = 0.155 m² · °C/W).
(From ASHRAE Standard 55-1981.)

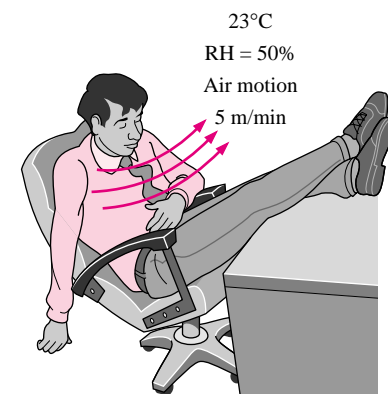

FIGURE 16-6

A thermally comfortable environment.

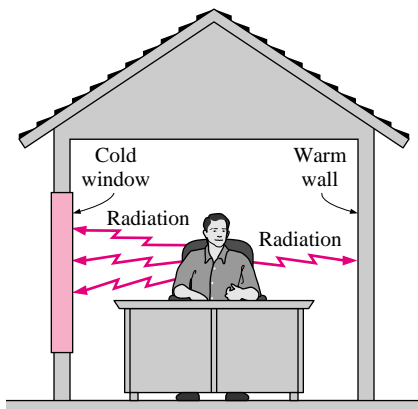

FIGURE 16-7

Cold surfaces cause excessive heat loss from the body by radiation, and thus discomfort on that side of the body.



FIGURE 16-8

The rate of metabolic heat generation may go up by 6 times the resting level during total body shivering in cold weather.

is deemed comfortable if only 10 percent of the people are dissatisfied with it. Metabolism decreases somewhat with *age*, but it has no effect on the comfort zone. Research indicates that there is no appreciable difference between the environments preferred by old and young people. Experiments also show that *men* and *women* prefer almost the same environment. The metabolism rate of women is somewhat lower, but this is compensated by their slightly lower skin temperature and evaporative loss. Also, there is no significant variation in the comfort zone from one part of the world to another and from winter to summer. Therefore, the same thermal comfort conditions can be used *throughout the world* in any season. Also, people cannot *acclimatize* themselves to prefer different comfort conditions.

In a **cold environment**, the rate of heat loss from the body may exceed the rate of metabolic heat generation. Average specific heat of the human body is $3.49 \text{ kJ/kg} \cdot ^\circ\text{C}$, and thus each 1°C drop in body temperature corresponds to a deficit of 244 kJ in body heat content for an average 70 kg man. A drop of 0.5°C in mean body temperature causes noticeable but acceptable discomfort. A drop of 2.6°C causes extreme discomfort. A sleeping person will wake up when his or her mean body temperature drops by 1.3°C (which normally shows up as a 0.5°C drop in the deep body and 3°C in the skin area). The drop of deep body temperature below 35°C may damage the body temperature regulation mechanism, while a drop below 28°C may be fatal. Sedentary people reported to feel *comfortable* at a *mean skin temperature* of 33.3°C , *uncomfortably cold* at 31°C , *shivering cold* at 30°C , and *extremely cold* at 29°C . People doing heavy work reported to feel comfortable at much lower temperatures, which shows that the activity level affects human performance and comfort. The extremities of the body such as hands and feet are most easily affected by cold weather, and their temperature is a better indication of comfort and performance. A hand-skin temperature of 20°C is perceived to be uncomfortably cold, 15°C to be extremely cold, and 5°C to be painfully cold. Useful work can be performed by hands without difficulty as long as the skin temperature of fingers remains above 16°C (ASHRAE *Handbook of Fundamentals*, Chap. 8).

The first line of defense of the body against excessive heat loss in a cold environment is to *reduce the skin temperature* and thus the rate of heat loss from the skin by constricting the veins and decreasing the blood flow to the skin. This measure decreases the temperature of the tissues subjacent to the skin, but maintains the inner body temperature. The next preventive measure is increasing the rate of *metabolic heat generation* in the body by *shivering*, unless the person does it voluntarily by increasing his or her level of activity or puts on additional clothing. Shivering begins slowly in small muscle groups and may double the rate of metabolic heat production of the body at its initial stages. In the extreme case of total body shivering, the rate of heat production may reach 6 times the resting levels (Fig. 16-8). If this measure also proves inadequate, the deep body temperature starts *falling*. Body parts furthest away from the core such as the hands and feet are at greatest danger for tissue damage.

In **hot environments**, the rate of heat loss from the body may drop below the metabolic heat generation rate. This time the body activates the opposite mechanisms. First the body increases the *blood flow* and thus heat transport to the skin, causing the temperature of the skin and the subjacent tissues to rise and approach the deep body temperature. Under extreme heat conditions, the

heart rate may reach 180 beats per minute in order to maintain adequate blood supply to the brain and the skin. At higher heart rates, the *volumetric efficiency* of the heart drops because of the very short time between the beats to fill the heart with blood, and the blood supply to the skin and more importantly to the brain drops. This causes the person to faint as a result of *heat exhaustion*. Dehydration makes the problem worse. A similar thing happens when a person working very hard for a long time stops suddenly. The blood that has flooded the skin has difficulty returning to the heart in this case since the relaxed muscles no longer force the blood back to the heart, and thus there is less blood available for pumping to the brain.

The next line of defense is releasing water from sweat glands and resorting to *evaporative cooling*, unless the person removes some clothing and reduces the activity level (Fig. 16-9). The body can maintain its core temperature at 37°C in this evaporative cooling mode indefinitely, even in environments at higher temperatures (as high as 200°C during military endurance tests), if the person drinks plenty of liquids to replenish his or her water reserves and the ambient air is sufficiently dry to allow the sweat to evaporate instead of rolling down the skin. If this measure proves inadequate, the body will have to start absorbing the metabolic heat and the deep body temperature will rise. A person can tolerate a temperature rise of 1.4°C without major discomfort but may *collapse* when the temperature rise reaches 2.8°C. People feel sluggish and their efficiency drops considerably when the core body temperature rises above 39°C. A core temperature above 41°C may damage hypothalamic proteins, resulting in cessation of sweating, increased heat production by shivering, and a *heat stroke* with an irreversible and life-threatening damage. Death can occur above 43°C.

A surface temperature of 46°C causes pain on the skin. Therefore, direct contact with a metal block at this temperature or above is painful. However, a person can stay in a room at 100°C for up to 30 min without any damage or pain on the skin because of the convective resistance at the skin surface and evaporative cooling. We can even put our hands into an oven at 200°C for a short time without getting burned.

Another factor that affects thermal comfort, health, and productivity is **ventilation**. Fresh outdoor air can be provided to a building *naturally* by doing nothing, or *forcefully* by a mechanical ventilation system. In the first case, which is the norm in residential buildings, the necessary ventilation is provided by *infiltration through cracks and leaks* in the living space and by the opening of the windows and doors. The additional ventilation needed in the bathrooms and kitchens is provided by *air vents with dampers* or *exhaust fans*. With this kind of uncontrolled ventilation, however, the fresh air supply will be either too high, wasting energy, or too low, causing poor indoor air quality. But the current practice is not likely to change for residential buildings since there is not a public outcry for energy waste or air quality, and thus it is difficult to justify the cost and complexity of mechanical ventilation systems.

Mechanical ventilation systems are part of any heating and air-conditioning system in *commercial buildings*, providing the necessary amount of fresh outdoor air and distributing it uniformly throughout the building. This is not surprising since many rooms in large commercial buildings have no windows and thus rely on mechanical ventilation. Even the rooms with windows are in the same situation since the windows are tightly sealed and cannot be opened in

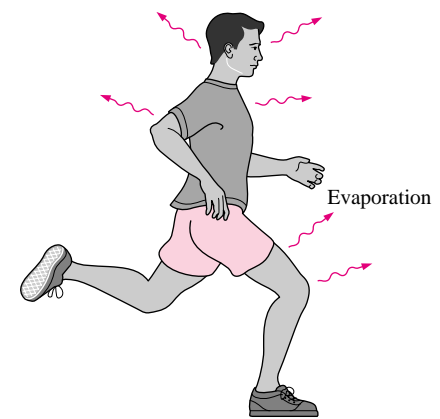

FIGURE 16-9

In hot environments, a body can dissipate a large amount of metabolic heat by sweating since the sweat absorbs the body heat and evaporates.



TABLE 16-2

Minimum fresh air requirements in buildings (from ASHRAE Standard 62-1989)

Application	Requirement	
	L/s per person	ft ³ /min per person
Classrooms, laundries, libraries, supermarkets	8	15
Dining rooms, conference rooms, offices	10	20
Hospital rooms	13	25
Hotel rooms	15	30
	(per room)	(per room)
Smoking lounges	30	60
Retail stores	1.0–1.5	0.2–0.3
	(per m ²)	(per ft ²)
Residential buildings	0.35 air change per hour, but not less than 7.5 L/s (or 15 ft ³ /min) per person	

most buildings. It is not a good idea to oversize the ventilation system just to be on the “safe side” since exhausting the heated or cooled indoor air wastes energy. On the other hand, reducing the ventilation rates below the required minimum to conserve energy should also be avoided so that the indoor air quality can be maintained at the required levels. The minimum fresh air ventilation requirements are listed in Table 16-2. The values are based on controlling the CO₂ and other contaminants with an adequate margin of safety, which requires each person be supplied with at least 7.5 L/s of fresh air.

Another function of the mechanical ventilation system is to **clean** the air by filtering it as it enters the building. Various types of filters are available for this purpose, depending on the cleanliness requirements and the allowable pressure drop.

16-3 ■ HEAT TRANSFER FROM THE HUMAN BODY

The metabolic heat generated in the body is dissipated to the environment through the skin and the lungs by convection and radiation as *sensible heat* and by evaporation as *latent heat* (Fig. 16-10). Latent heat represents the heat of vaporization of water as it evaporates in the lungs and on the skin by absorbing body heat, and latent heat is released as the moisture condenses on cold surfaces. The warming of the inhaled air represents sensible heat transfer in the lungs and is proportional to the temperature rise of inhaled air. The total rate of heat loss from the body can be expressed as

$$\begin{aligned} \dot{Q}_{\text{body, total}} &= \dot{Q}_{\text{skin}} + \dot{Q}_{\text{lungs}} \\ &= (\dot{Q}_{\text{sensible}} + \dot{Q}_{\text{latent}})_{\text{skin}} + (\dot{Q}_{\text{sensible}} + \dot{Q}_{\text{latent}})_{\text{lungs}} \\ &= (\dot{Q}_{\text{convection}} + \dot{Q}_{\text{radiation}} + \dot{Q}_{\text{latent}})_{\text{skin}} + (\dot{Q}_{\text{convection}} + \dot{Q}_{\text{latent}})_{\text{lungs}} \end{aligned} \quad (16-2)$$

Therefore, the determination of heat transfer from the body by analysis alone is difficult. Clothing further complicates the heat transfer from the body, and thus we must rely on experimental data. Under steady conditions, the total rate of heat transfer from the body is equal to the rate of metabolic heat generation in the body, which varies from about 100 W for light office work to roughly 1000 W during heavy physical work.

Sensible heat loss from the skin depends on the temperatures of the skin, the environment, and the surrounding surfaces as well as the air motion. The *latent heat loss*, on the other hand, depends on the skin wettedness and the relative humidity of the environment as well. *Clothing* serves as insulation and reduces both the sensible and latent forms of heat loss. The heat transfer from the lungs through respiration obviously depends on the frequency of breathing and the volume of the lungs as well as the environmental factors that affect heat transfer from the skin.

Sensible heat from the clothed skin is first transferred to the clothing and then from the clothing to the environment. The convection and radiation heat losses from the outer surface of a clothed body can be expressed as

$$\dot{Q}_{\text{conv}} = h_{\text{conv}} A_{\text{clothing}} (T_{\text{clothing}} - T_{\text{ambient}}) \quad (\text{W}) \quad (16-3)$$

$$\dot{Q}_{\text{rad}} = h_{\text{rad}} A_{\text{clothing}} (T_{\text{clothing}} - T_{\text{surr}}) \quad (16-4)$$

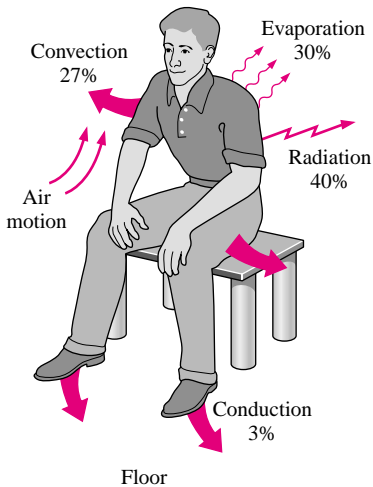
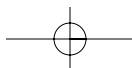

FIGURE 16-10 Mechanisms of heat loss from the human body and relative magnitudes for a resting person.



where

h_{conv} = convection heat transfer coefficient, as given in Table 16–3

h_{rad} = radiation heat transfer coefficient, $4.7 \text{ W/m}^2 \cdot ^\circ\text{C}$ for typical indoor conditions; the emissivity is assumed to be 0.95, which is typical

A_{clothing} = outer surface area of a clothed person

T_{clothing} = average temperature of exposed skin and clothing

T_{ambient} = ambient air temperature

T_{surr} = average temperature of the surrounding surfaces

The convection heat transfer coefficients at 1 atm pressure are given in Table 16–3. Convection coefficients at pressures P other than 1 atm are obtained by multiplying the values at atmospheric pressure by $P^{0.55}$ where P is in atm. Also, it is recognized that the temperatures of different surfaces surrounding a person are probably different, and T_{surr} represents the *mean radiation temperature*, which is the temperature of an imaginary isothermal enclosure in which radiation heat exchange with the human body equals the radiation heat exchange with the actual enclosure. Noting that most clothing and building materials are very nearly black, the *mean radiation temperature* of an enclosure that consists of N surfaces at different temperatures can be determined from

$$T_{\text{surr}} \cong F_{\text{person-1}}T_1 + F_{\text{person-2}}T_2 + \cdots + F_{\text{person-N}}T_N \quad (16-5)$$

where T_i is the *temperature of the surface i* and $F_{\text{person-}i}$ is the *view factor* between the person and surface i .

Total sensible heat loss can also be expressed conveniently by combining the convection and radiation heat losses as

$$\dot{Q}_{\text{conv+rad}} = h_{\text{combined}}A_{\text{clothing}}(T_{\text{clothing}} - T_{\text{operative}}) \quad (16-6)$$

$$= (h_{\text{conv}} + h_{\text{rad}})A_{\text{clothing}}(T_{\text{clothing}} - T_{\text{operative}}) \quad (\text{W}) \quad (16-7)$$

where the **operative temperature** $T_{\text{operative}}$ is the average of the mean radiant and ambient temperatures weighed by their respective convection and radiation heat transfer coefficients and is expressed as (Fig. 16–11)

$$T_{\text{operative}} = \frac{h_{\text{conv}}T_{\text{ambient}} + h_{\text{rad}}T_{\text{surr}}}{h_{\text{conv}} + h_{\text{rad}}} \cong \frac{T_{\text{ambient}} + T_{\text{surr}}}{2} \quad (16-8)$$

Note that the operative temperature will be the arithmetic average of the ambient and surrounding surface temperatures when the convection and radiation heat transfer coefficients are equal to each other. Another environmental index used in thermal comfort analysis is the **effective temperature**, which combines the effects of temperature and humidity. Two environments with the same effective temperature evokes the same thermal response in people even though they are at different temperatures and humidities.

Heat transfer through the *clothing* can be expressed as

$$\dot{Q}_{\text{conv+rad}} = \frac{A_{\text{clothing}}(T_{\text{skin}} + T_{\text{clothing}})}{R_{\text{clothing}}} \quad (16-9)$$

TABLE 16–3

Convection heat transfer coefficients for a clothed body at 1 atm V is in m/s) (compiled from various sources)

Activity	h_{conv}^* $\text{W/m}^2 \cdot ^\circ\text{C}$
Seated in air moving at	
$0 < V < 0.2 \text{ m/s}$	3.1
$0.2 < V < 4 \text{ m/s}$	$8.3V^{0.6}$
Walking in still air at	
$0.5 < V < 2 \text{ m/s}$	$8.6V^{0.53}$
Walking on treadmill in still air at $0.5 < V < 2 \text{ m/s}$	
2 m/s	$6.5V^{0.39}$
Standing in moving air at	
$0 < V < 0.15 \text{ m/s}$	4.0
$0.15 < V < 1.5 \text{ m/s}$	$14.8V^{0.69}$

*At pressures other than 1 atm, multiply by $P^{0.55}$, where P is in atm.

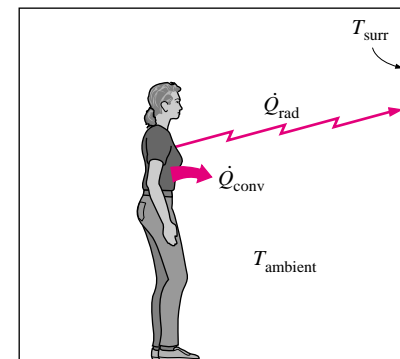

(a) Convection and radiation, separate

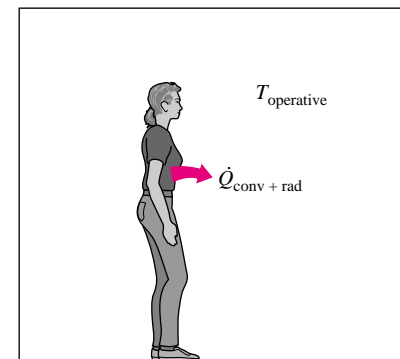

(b) Convection and radiation, combined

FIGURE 16–11

Heat loss by convection and radiation from the body can be combined into a single term by defining an equivalent operative temperature.

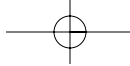

16-10
HEATING AND COOLING OF BUILDINGS

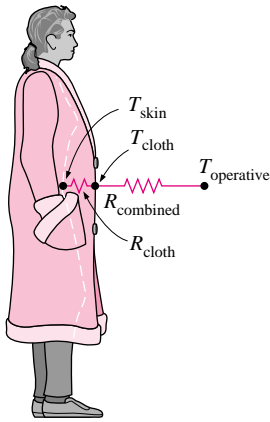

FIGURE 16-12
Simplified thermal resistance network for heat transfer from a clothed person.

where R_{clothing} is the **unit thermal resistance of clothing** in $\text{m}^2 \cdot ^\circ\text{C}/\text{W}$, which involves the combined effects of conduction, convection, and radiation between the skin and the outer surface of clothing. The thermal resistance of clothing is usually expressed in the unit **clo** where $1 \text{ clo} = 0.155 \text{ m}^2 \cdot ^\circ\text{C}/\text{W}$. The thermal resistance of trousers, long-sleeve shirt, long-sleeve sweater, and T-shirt is 1.0 clo, or $0.155 \text{ m}^2 \cdot ^\circ\text{C}/\text{W}$. Summer clothing such as light slacks and short-sleeved shirt has an insulation value of 0.5 clo, whereas winter clothing such as heavy slacks, long-sleeve shirt, and a sweater or jacket has an insulation value of 0.9 clo.

Then the total sensible heat loss can be expressed in terms of the skin temperature instead of the inconvenient clothing temperature as (Fig. 16-12)

$$\dot{Q}_{\text{conv} + \text{rad}} = \frac{A_{\text{clothing}}(T_{\text{skin}} - T_{\text{operative}})}{R_{\text{clothing}} + \frac{1}{h_{\text{combined}}}} \quad (16-10)$$

At a state of thermal comfort, the average skin temperature of the body is observed to be 33°C . No discomfort is experienced as the skin temperature fluctuates by $\pm 1.5^\circ\text{C}$. This is the case whether the body is clothed or unclothed.

Evaporative or latent heat loss from the skin is proportional to the difference between the water vapor pressure at the skin and the ambient air, and the skin wettedness, which is a measure of the amount of moisture on the skin. It is due to the combined effects of the *evaporation of sweat* and the *diffusion of water* through the skin, and can be expressed as

$$\dot{Q}_{\text{latent}} = \dot{m}_{\text{vapor}} \eta_{fg} \quad (16-11)$$

where

\dot{m}_{vapor} = the rate of evaporation from the body, kg/s

h_{fg} = the enthalpy of vaporization of water = 2430 kJ/kg at 30°C

Heat loss by evaporation is maximum when the skin is completely wetted. Also, clothing offers resistance to evaporation, and the rate of evaporation in clothed bodies depends on the moisture permeability of the clothes. The maximum evaporation rate for an average man is about 1 L/h (0.3 g/s), which represents an upper limit of 730 W for the evaporative cooling rate. A person can lose as much as 2 kg of water per hour during a workout on a hot day, but any excess sweat slides off the skin surface without evaporating (Fig. 16-13).

During *respiration*, the inhaled air enters at ambient conditions and exhaled air leaves nearly saturated at a temperature close to the deep body temperature (Fig. 16-14). Therefore, the body loses both sensible heat by convection and latent heat by evaporation from the lungs, and these can be expressed as

$$\dot{Q}_{\text{conv, lungs}} = \dot{m}_{\text{air, lungs}} c_{p, \text{air}} (T_{\text{exhale}} - T_{\text{ambient}}) \quad (16-12)$$

$$\dot{Q}_{\text{latent, lungs}} = \dot{m}_{\text{vapor, lungs}} h_{fg} = \dot{m}_{\text{air, lungs}} (\omega_{\text{exhale}} - \omega_{\text{ambient}}) h_{fg} \quad (16-13)$$

where

$\dot{m}_{\text{air, lungs}}$ = rate of air intake to the lungs, kg/s

$c_{p, \text{air}}$ = specific heat of air = 1.0 kJ/kg $\cdot ^\circ\text{C}$

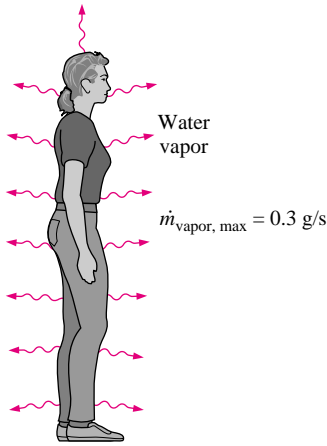

$$\begin{aligned} \dot{Q}_{\text{latent, max}} &= \dot{m}_{\text{latent, max}} h_{fg} @ 30^\circ\text{C} \\ &= (0.3 \text{ g/s})(2430 \text{ kJ/kg}) \\ &= 729 \text{ W} \end{aligned}$$

FIGURE 16-13
An average person can lose heat at a rate of up to 730 W by evaporation.

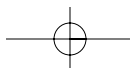



T_{exhale} = temperature of exhaled air
 ω = humidity ratio (the mass of moisture per unit mass of dry air)

The rate of air intake to the lungs is directly proportional to the metabolic rate \dot{Q}_{met} . The rate of total heat loss from the lungs through respiration can be expressed approximately as

$$\dot{Q}_{\text{conv} + \text{latent, lungs}} = 0.0014\dot{Q}_{\text{met}}(34 - T_{\text{ambient}}) + 0.0173\dot{Q}_{\text{met}}(5.87 - P_{v, \text{ambient}}) \quad (16-14)$$

where $P_{v, \text{ambient}}$ is the vapor pressure of ambient air in kPa.

The fraction of sensible heat varies from about 40 percent in the case of heavy work to about 70 percent during light work. The rest of the energy is rejected from the body by perspiration in the form of latent heat.

EXAMPLE 16-1 Effect of Clothing on Thermal Comfort

It is well established that a clothed or unclothed person feels comfortable when the skin temperature is about 33°C. Consider an average man wearing summer clothes whose thermal resistance is 0.6 clo. The man feels very comfortable while standing in a room maintained at 22°C. The air motion in the room is negligible, and the interior surface temperature of the room is about the same as the air temperature. If this man were to stand in that room unclothed, determine the temperature at which the room must be maintained for him to feel thermally comfortable.

SOLUTION A man wearing summer clothes feels comfortable in a room at 22°C. The room temperature at which this man would feel thermally comfortable when unclothed is to be determined.

Assumptions 1 Steady conditions exist. 2 The latent heat loss from the person remains the same. 3 The heat transfer coefficients remain the same.

Analysis The body loses heat in sensible and latent forms, and the sensible heat consists of convection and radiation heat transfer. At low air velocities, the convection heat transfer coefficient for a standing man is given in Table 16-3 to be 4.0 W/m² · °C. The radiation heat transfer coefficient at typical indoor conditions is 4.7 W/m² · °C. Therefore, the surface heat transfer coefficient for a standing person for combined convection and radiation is

$$h_{\text{combined}} = h_{\text{conv}} + h_{\text{rad}} = 4.0 + 4.7 = 8.7 \text{ W/m}^2 \cdot \text{°C}$$

The thermal resistance of the clothing is given to be

$$R_{\text{clothing}} = 0.6 \text{ clo} = 0.6 \times 0.155 \text{ m}^2 \cdot \text{°C/W} = 0.093 \text{ m}^2 \cdot \text{°C/W}$$

Noting that the surface area of an average man is 1.8 m², the sensible heat loss from this person when clothed is determined to be (Fig. 16-15)

$$\dot{Q}_{\text{sensible, clothed}} = \frac{A_s(T_{\text{skin}} - T_{\text{ambient}})}{R_{\text{clothing}} + \frac{1}{h_{\text{combined}}}} = \frac{(1.8 \text{ m}^2)(33 - 22)\text{°C}}{0.093 \text{ m}^2 \cdot \text{°C/W} + \frac{1}{8.7 \text{ W/m}^2 \cdot \text{°C}}} = 95.2 \text{ W}$$

From a heat transfer point of view, taking the clothes off is equivalent to removing the clothing insulation or setting $R_{\text{clothing}} = 0$. The heat transfer in this case can be expressed as

16-11 CHAPTER 16

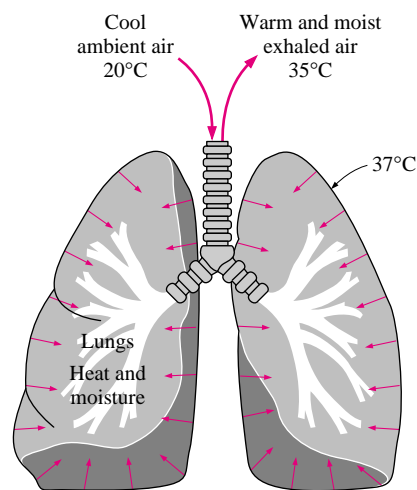

FIGURE 16-14 Part of the metabolic heat generated in the body is rejected to the air from the lungs during respiration.

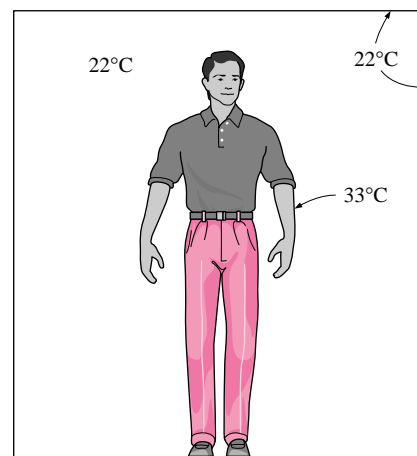

FIGURE 16-15 Schematic for Example 16-1.

16-12
HEATING AND COOLING OF BUILDINGS

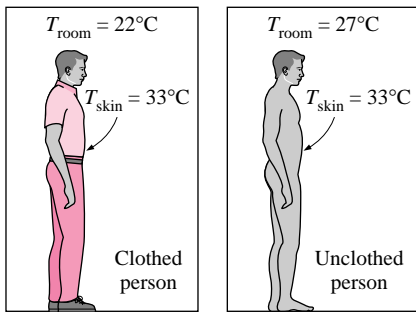

FIGURE 16-16

Clothing serves as insulation, and the room temperature needs to be raised when a person is unclothed to maintain the same comfort level.

$$\dot{Q}_{\text{sensible, unclothed}} = \frac{A_s(T_{\text{skin}} - T_{\text{ambient}})}{h_{\text{combined}}} = \frac{(1.8\text{m}^2)(33 - T_{\text{ambient}})^{\circ}\text{C}}{8.7\text{W/m}^2 \cdot ^{\circ}\text{C}}$$

To maintain thermal comfort after taking the clothes off, the skin temperature of the person and the rate of heat transfer from him must remain the same. Then setting the equation above equal to 95.2 W gives

$$T_{\text{ambient}} = 26.9^{\circ}\text{C}$$

Therefore, the air temperature needs to be raised from 22 to 26.9°C to ensure that the person will feel comfortable in the room after he takes his clothes off (Fig. 16-16).

Discussion Note that the effect of clothing on latent heat is assumed to be negligible in the solution above. We also assumed the surface area of the clothed and unclothed person to be the same for simplicity, and these two effects should counteract each other.

16-4 ■ DESIGN CONDITIONS FOR HEATING AND COOLING

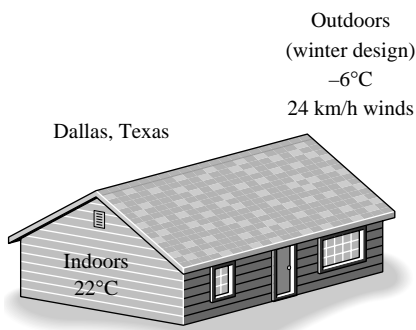

FIGURE 16-17

The size of a heating system is determined on the basis of heat loss during indoor and outdoor design conditions.

The size of a heating or cooling system for a building is determined on the basis of the desired indoor conditions that must be maintained based on the outdoor conditions that exist at that location. The desirable ranges of temperatures, humidities, and ventilation rates (the thermal comfort zone) discussed earlier constitute the typical **indoor design conditions**, and they remain fairly constant. For example, the recommended indoor temperature for general comfort heating is 22°C. The outdoor conditions at a location, on the other hand, vary greatly from year to year, month to month, and even hour to hour. The set of extreme outdoor conditions under which a heating or cooling system must be able to maintain a building at the indoor design conditions is called the **outdoor design conditions** (Fig. 16-17).

When designing a heating, ventilating, and air-conditioning (HVAC) system, perhaps the first thought that comes to mind is to select a system that is large enough to keep the indoors at the desired conditions at all times even under the *worst weather conditions*. But sizing an HVAC system on the basis of the most extreme weather on record is not practical since such an oversized system will have a higher initial cost, will occupy more space, and will probably have a higher operating cost because the equipment in this case will run at partial load most of time and thus at a lower efficiency. Most people would not mind experiencing an occasional slight discomfort under extreme weather conditions if it means a significant reduction in the initial and operating costs of the heating or cooling system. The question that arises naturally is *what is a good compromise between economics and comfort?*

To answer this question, we need to know what the weather will be like in the future. But even the best weather forecasters cannot help us with that. Therefore, we turn to the past instead of the future and bet that the past weather data averaged over several years will be representative of a typical year in the future. The weather data in Tables 16-4 and 16-5 are based on the records of numerous weather stations in the United States that recorded

TABLE 16-4

Weather data for selected cities in the United States
(from ASHRAE *Handbook of Fundamentals*, Chap. 24, Table 1)

State and station	Elevation		Winter				Summer					
	ft	m	99%		97 $\frac{1}{2}$ %		Dry bulb, 2 $\frac{1}{2}$ %		Wet bulb, 2 $\frac{1}{2}$ %		Daily range	
			°F	°C	°F	°C	°F	°C	°F	°C	°F	°C
Alabama, Birmingham AP	610	186	17	-8	21	-6	94	34	75	24	21	12
Alaska, Anchorage AP	90	27	-23	-31	-18	-28	68	20	58	14	15	8
Arizona, Tucson AP	2584	788	28	-2	32	0	102	39	66	19	26	14
Arkansas, Little Rock AP	257	78.3	15	-9	20	-7	96	36	77	25	22	12
California, San Francisco AP	8	2.4	35	2	38	3	77	25	63	17	20	11
Colorado, Denver AP	5283	1610	-5	-21	1	-17	91	33	59	15	28	16
Connecticut, Bridgeport AP	7	2.1	-6	-21	9	-13	84	29	71	22	18	10
Delaware, Wilmington AP	78	24	10	-12	14	-10	89	32	74	23	20	11
Florida, Tallahassee AP	58	18	27	-3	30	-1	92	33	76	24	19	11
Georgia, Atlanta AP	1005	306	17	-8	22	-6	92	33	74	23	19	11
Hawaii, Honolulu AP	7	2.1	62	17	63	17	86	30	73	23	12	7
Idaho, Boise AP	2842	866	3	-16	10	-12	94	34	64	18	31	17
Illinois, Chicago O'Hare AP	658	201	-8	-22	-4	-20	89	32	74	23	20	11
Indiana, Indianapolis AP	793	242	-2	-19	2	-17	90	32	74	23	22	12
Iowa, Sioux City AP	1095	334	-11	-24	-7	-22	92	33	74	23	24	13
Kansas, Wichita AP	1321	403	3	-16	7	-14	98	37	73	23	23	13
Kentucky, Louisville AP	474	144	5	-15	10	-12	93	34	75	24	23	13
Louisiana, Shreveport AP	252	76.8	20	-7	25	-4	96	36	76	24	20	11
Maryland, Baltimore AP	146	44.5	10	-12	13	-11	91	33	75	24	21	12
Massachusetts, Boston AP	15	4.6	-6	-14	9	-13	88	31	71	22	16	9
Michigan, Lansing AP	852	260	-3	-19	1	-17	87	31	72	22	24	13
Minnesota, Minneapolis/St. Paul	822	251	-16	-27	-12	-24	89	32	73	23	22	12
Mississippi, Jackson AP	330	101	21	-6	25	-4	95	35	76	24	21	12
Missouri, Kansas City AP	742	226	2	-17	6	-14	96	36	74	23	20	11
Montana, Billings AP	3567	1087	-15	-26	-10	-23	91	33	64	18	31	17
Nebraska, Lincoln CO	1150	351	-5	-21	-2	-19	95	35	74	23	24	13
Nevada, Las Vegas AP	2162	659	25	-4	28	-2	106	41	65	18	30	17
New Mexico, Albuquerque AP	5310	1618	12	-11	16	-9	94	34	61	16	30	17
New York, Syracuse AP	424	129	-3	-19	2	-17	87	31	71	22	20	11
North Carolina, Charlotte AP	735	224	18	-8	22	-6	93	34	74	23	20	11
Ohio, Cleveland AP	777	237	1	-17	5	-15	88	31	72	22	22	12
Oklahoma, Stillwater	884	269	8	-13	13	-11	96	36	74	23	24	13
Oregon, Pendleton AP	1492	455	-2	-19	5	-15	93	34	64	18	29	16
Pennsylvania, Pittsburgh AP	1137	347	1	-17	5	-15	86	30	71	22	22	12
South Carolina, Charleston AFB	41	12	24	-4	27	-3	91	33	78	26	18	10
Tennessee, Memphis AP	263	80.2	13	-11	18	-8	95	35	76	24	21	12
Texas, Dallas AP	481	147	18	-8	22	-6	100	38	75	24	20	11
Utah, Salt Lake City	4220	1286	3	-16	8	-13	95	35	62	17	32	18
Virginia, Norfolk AP	26	7.9	20	-7	22	-6	91	33	76	24	18	10
Washington, Spokane AP	2357	718	-6	-21	2	-17	90	32	63	17	28	16

TABLE 16-5

Average winter temperatures and number of degree-days for selected cities in the United States
(from ASHRAE *Handbook of Systems*, 1980)

State and station	Average winter temp.		Degree days, °F-day												Yearly total
	°F	°C	July	Aug.	Sep.	Oct.	Nov.	Dec.	Jan.	Feb.	March	April	May	June	
Alabama, Birmingham	54.2	12.7	0	0	6	93	363	555	592	462	363	108	9	0	2551
Alaska, Anchorage	23.0	5.0	245	291	516	930	1284	1572	1631	1316	1293	879	592	315	10,864
Arizona, Tucson	58.1	14.8	0	0	0	25	231	406	471	344	242	75	6	0	1800
California, San Francisco	53.4	12.2	82	78	60	143	306	462	508	395	363	279	214	126	3015
Colorado, Denver	37.6	3.44	6	9	117	428	819	1035	1132	938	887	558	288	66	6283
Florida, Tallahassee	60.1	15.9	0	0	0	28	198	360	375	286	202	86	0	0	1485
Georgia, Atlanta	51.7	11.28	0	0	18	124	417	648	636	518	428	147	25	0	2961
Hawaii, Honolulu	74.2	23.8	0	0	0	0	0	0	0	0	0	0	0	0	0
Idaho, Boise	39.7	4.61	0	0	132	415	792	1017	1113	854	722	438	245	81	5809
Illinois, Chicago	35.8	2.44	0	12	117	381	807	1166	1265	1086	939	534	260	72	6639
Indiana, Indianapolis	39.6	4.56	0	0	90	316	723	1051	1113	949	809	432	177	39	5699
Iowa, Sioux City	43.0	1.10	0	9	108	369	867	1240	1435	1198	989	483	214	39	6951
Kansas, Wichita	44.2	7.11	0	0	33	229	618	905	1023	804	645	270	87	6	4620
Kentucky, Louisville	44.0	6.70	0	0	54	248	609	890	930	818	682	315	105	9	4660
Louisiana, Shreveport	56.2	13.8	0	0	0	47	297	477	552	426	304	81	0	0	2184
Maryland, Baltimore	43.7	6.83	0	0	48	264	585	905	936	820	679	327	90	0	4654
Massachusetts, Boston	40.0	4.40	0	9	60	316	603	983	1088	972	846	513	208	36	5634
Michigan, Lansing	34.8	1.89	6	22	138	431	813	1163	1262	1142	1011	579	273	69	6909
Minnesota, Minneapolis	28.3	-1.72	22	31	189	505	1014	1454	1631	1380	1166	621	288	81	8382
Montana, Billings	34.5	1.72	6	15	186	487	897	1135	1296	1100	970	570	285	102	7049
Nebraska, Lincoln	38.8	4.11	0	6	75	301	726	1066	1237	1016	834	402	171	30	5864
Nevada, Las Vegas	53.5	12.28	0	0	0	78	387	617	688	487	335	111	6	0	2709
New York, Syracuse	35.2	2.11	6	28	132	415	744	1153	1271	1140	1004	570	248	45	6756
North Carolina, Charlotte	50.4	10.56	0	0	6	124	438	691	691	582	481	156	22	0	3191
Ohio, Cleveland	37.2	3.22	9	25	105	384	738	1088	1159	1047	918	552	260	66	6351
Oklahoma, Stillwater	48.3	9.39	0	0	15	164	498	766	868	664	527	189	34	0	3725
Pennsylvania, Pittsburgh	38.4	3.89	0	9	105	375	726	1063	1119	1002	874	480	195	39	5987
Tennessee, Memphis	50.5	10.6	0	0	18	130	447	698	729	585	456	147	22	0	3232
Texas, Dallas	55.3	13.3	0	0	0	62	321	524	601	440	319	90	6	0	2363
Utah, Salt Lake City	38.4	3.89	0	0	81	419	849	1082	1172	910	763	459	233	84	6052
Virginia, Norfolk	49.2	9.89	0	0	0	136	408	698	738	655	533	216	37	0	3421
Washington, Spokane	36.5	2.83	9	25	168	493	879	1082	1231	980	834	531	288	135	6655

*Based on degrees F; quantities may be converted to degree days based on degrees C by dividing by 1.8. This assumes 18°C corresponds to 65°F.

various weather data in hourly intervals. For ordinary buildings, it turns out that the economics and comfort meet at the 97.5 percent level in winter. That is, the heating system will provide thermal comfort 97.5 percent of the time but may fail to do so during 2.5 percent of the time (Fig. 16-18). For example,

the 97.5 percent winter design temperature for Denver, Colorado, is -17°C , and thus the temperatures in Denver may fall below -17°C about 2.5 percent of the time during winter months in a typical year. Critical applications such as health care facilities and certain process industries may require the more stringent 99 percent level.

Table 16-4 lists the outdoor design conditions for both cases as well as summer comfort levels. The winter percentages are based on the weather data for the months of December, January, and February while the summer percentages are based on the four months June through September. The three winter months have a total of $31 + 31 + 28 = 90$ days and thus 2160 hours. Therefore, the conditions of a house whose heating system is based on the 97.5 percent level may fall below the comfort level for $2160 \times 2.5\% = 54$ hours during the heating season of a typical year. However, most people will not even notice it because everything in the house will start giving off heat as soon as the temperature drops below the thermostat setting. This is especially the case in buildings with large thermal masses. The minimum temperatures usually occur between 6:00 AM and 8:00 AM solar time, and thus commercial buildings that open late (such as shopping centers) may even use less stringent outdoor design conditions (such as the 95 percent level) for their heating systems. This is also the case with the cooling systems of residences that are unoccupied during the maximum temperatures, which occur between 2:00 PM and 4:00 PM solar time in the summer.

The **heating or cooling loads** of a building represent the heat that must be supplied to or removed from the interior of a building to maintain it at the desired conditions. A distinction should be made between the *design load* and the *actual load* of heating or cooling systems. The *design* (or *peak*) heating load is usually determined with a steady-state analysis using the design conditions for the indoors and the outdoors for the purpose of *sizing* the heating system (Fig. 16-19). This ensures that the system has the required capacity to perform adequately at the anticipated worst conditions. But the energy use of a building during a heating or cooling season is determined on the basis of the *actual* heating or cooling load, which varies throughout the day.

The **internal heat load** (the heat dissipated off by people, lights, and appliances in a building) is usually not considered in the determination of the design heating load but is considered in the determination of the design cooling load. This is to ensure that the heating system selected can heat the building even when there is no contribution from people or appliances, and the cooling system is capable of cooling it even when the heat given off by people and appliances is at its highest level.

Wind increases heat transfer to or from the walls, roof, and windows of a building by increasing the convection heat transfer coefficient and also increasing the infiltration. Therefore, **wind speed** is another consideration when determining the heating and cooling loads. The recommended values of wind speed to be considered are 24 km/h for winter and 12 km/h for summer. The corresponding design values recommended by ASHRAE for heat transfer coefficients for combined convection and radiation on the *outer surface* of a building are

$$h_{o,\text{winter}} = 34.0 \text{ W/m}^2 \cdot \text{C}$$

$$h_{o,\text{summer}} = 22.7 \text{ W/m}^2 \cdot \text{C}$$

SALT LAKE CITY, UTAH	
97.5% Winter design temp = -13°C	
No. of hours during winter (Dec., Jan., and Feb.) = $90 \times 24 = 2160$ hours	
Therefore,	
T_{outdoor}	$> -13^{\circ}\text{C}$ for 2106 h (97.5%)
	$< -13^{\circ}\text{C}$ for 54 h (2.5%)

FIGURE 16-18

The 97.5 percent winter design temperature represents the outdoor temperature that will be exceeded during 97.5 percent of the time in winter.

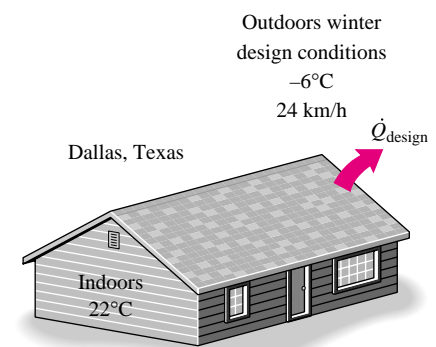

FIGURE 16-19

The design heat load of a building represents the heat loss of a building during design conditions at the indoors and the outdoors.

16-16
HEATING AND COOLING OF BUILDINGS

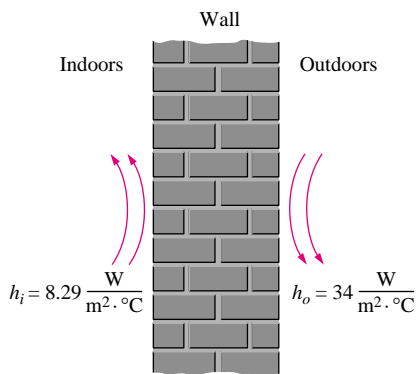

FIGURE 16-20

Recommended winter design values for heat transfer coefficients for combined convection and radiation on the outer and inner surfaces of a building.

The recommended heat transfer coefficient value for the *interior surfaces* of a building for both summer and winter is (Fig. 16-20)

$$h_i = 8.29 \text{ W/m}^2 \cdot \text{C}$$

For well-insulated buildings, the surface heat transfer coefficients constitute a small part of the overall heat transfer coefficients, and thus the effect of possible deviations from the above values is usually insignificant.

In summer, the **moisture level** of the outdoor air is much higher than that of indoor air. Therefore, the excess moisture that enters a house from the outside with infiltrating air needs to be condensed and removed by the cooling system. But this requires the removal of the latent heat from the moisture, and the cooling system must be large enough to handle this excess cooling load. To size the cooling system properly, we need to know the moisture level of the outdoor air at design conditions. This is usually done by specifying the wet-bulb temperature, which is a good indicator of the amount of moisture in the air. The moisture level of the cold outside air is very low in winter, and thus normally it does not affect the heating load of a building.

Solar radiation plays a major role on the heating and cooling of buildings, and you may think that it should be an important consideration in the evaluation of the design heating and cooling loads. Well, it turns out that peak heating loads usually occur early in the mornings just before sunrise. Therefore, solar radiation does not affect the *peak* or *design heating load* and thus the size of a heating system. However, it has a major effect on the actual heating load, and solar radiation can reduce the annual heating energy consumption of a building considerably.

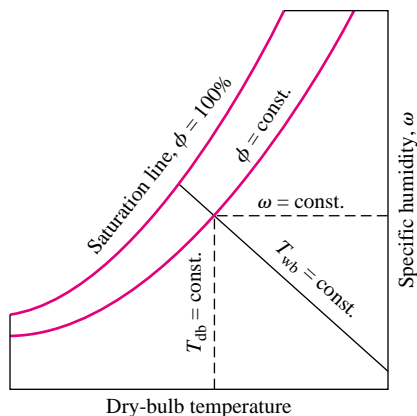

FIGURE 16-21

Determination of the relative humidity and the humidity ratio of air from the psychrometric chart when the wet-bulb and ambient temperatures are given.

EXAMPLE 16-2 Summer and Winter Design Conditions for Atlanta

Determine the outdoor design conditions for Atlanta, Georgia, for summer for the 2.5 percent level and for winter for the 97.5 percent and 99 percent levels.

SOLUTION The climatic conditions for major cities in the United States are listed in Table 16-4, and for the indicated design levels we read

Winter:	$T_{\text{outdoor}} = -6^{\circ}\text{C}$	(97.5 percent level)
Winter:	$T_{\text{outdoor}} = -8^{\circ}\text{C}$	(99 percent level)
Summer:	$T_{\text{outdoor}} = 33^{\circ}\text{C}$	
	$T_{\text{wet-bulb}} = 23^{\circ}\text{C}$	(2.5 percent level)

Therefore, the heating and cooling systems in Atlanta for common applications should be sized for these outdoor conditions. Note that when the wet-bulb and ambient temperatures are available, the relative humidity and the humidity ratio of air can be determined from the psychrometric chart (Fig. 16-21).

Sol-Air Temperature

The sun is the main heat source of the earth, and without the sun, the environment temperature would not be much higher than the deep space temperature of -270°C . The solar energy stored in the atmospheric air, the ground, and the structures such as buildings during the day is slowly released at night, and thus



the variation of the outdoor temperature is governed by the *incident solar radiation* and the *thermal inertia* of the earth. Heat gain from the sun is the primary reason for installing cooling systems, and thus solar radiation has a major effect on the *peak* or *design cooling load* of a building, which usually occurs early in the afternoon as a result of the solar radiation entering through the glazing directly and the radiation absorbed by the walls and the roof that is released later in the day.

The effect of solar radiation for glazing such as windows is expressed in terms of the *solar heat gain factor* (SHGF), discussed later in this chapter. For opaque surfaces such as the walls and the roof, on the other hand, the effect of solar radiation is conveniently accounted for by considering the outside temperature to be higher by an amount equivalent to the effect of solar radiation. This is done by replacing the ambient temperature in the heat transfer relation through the walls and the roof by the **sol-air temperature**, which is defined as *the equivalent outdoor air temperature that gives the same rate of heat transfer to a surface as would the combination of incident solar radiation, convection with the ambient air, and radiation exchange with the sky and the surrounding surfaces* (Fig. 16-22).

Heat flow into an exterior surface of a building subjected to solar radiation can be expressed as

$$\begin{aligned} \dot{Q}_{\text{surface}} &= \dot{Q}_{\text{conv + rad}} + \dot{Q}_{\text{solar}} - \dot{Q}_{\text{radiation correction}} \\ &= h_o A_s (T_{\text{ambient}} - T_{\text{surface}}) + \alpha_s A_s \dot{q}_{\text{solar}} - \varepsilon A_s \sigma (T_{\text{ambient}}^4 - T_{\text{surr}}^4) \\ &= h_o A_s (T_{\text{sol-air}} - T_{\text{surface}}) \end{aligned} \quad (16-15)$$

where α_s is the *solar absorptivity* and ε is the *emissivity* of the surface, h_o is the combined convection and radiation heat transfer coefficient, \dot{q}_{solar} is the solar radiation incident on the surface (in W/m²) and

$$T_{\text{sol-air}} = T_{\text{ambient}} + \frac{\alpha_s \dot{q}_{\text{solar}}}{h_o} - \frac{\varepsilon \sigma (T_{\text{ambient}}^4 - T_{\text{surr}}^4)}{h_o} \quad (16-16)$$

is the sol-air temperature. The first term in Equation 16-15 represents the convection and radiation heat transfer to the surface when the average surrounding surface and sky temperature is equal to the ambient air temperature, $T_{\text{surr}} = T_{\text{ambient}}$, and the last term represents the correction for the radiation heat transfer when $T_{\text{surr}} \neq T_{\text{ambient}}$. The last term in the sol-air temperature relation represents the equivalent change in the ambient temperature corresponding to this radiation correction effect and ranges from about zero for vertical wall surfaces to 4°C for horizontal or inclined roof surfaces facing the sky. This difference is due to the low effective sky temperature.

The sol-air temperature for a surface obviously depends on the absorptivity of the surface for solar radiation, which is listed in Table 16-6 for common exterior surfaces. Being conservative and taking $h_o = 17 \text{ W/m}^2 \cdot \text{°C}$, the summer design values of the ratio α_s/h_o for light- and dark-colored surfaces are determined to be (Fig. 16-23)

$$\begin{aligned} \left(\frac{\alpha_s}{h_o}\right)_{\text{light}} &= \frac{0.45}{17 \text{ W/m}^2 \cdot \text{°C}} = 0.026 \text{ m}^2 \cdot \text{°C/W} \\ \left(\frac{\alpha_s}{h_o}\right)_{\text{dark}} &= \frac{0.90}{17 \text{ W/m}^2 \cdot \text{°C}} = 0.052 \text{ m}^2 \cdot \text{°C/W} \end{aligned}$$

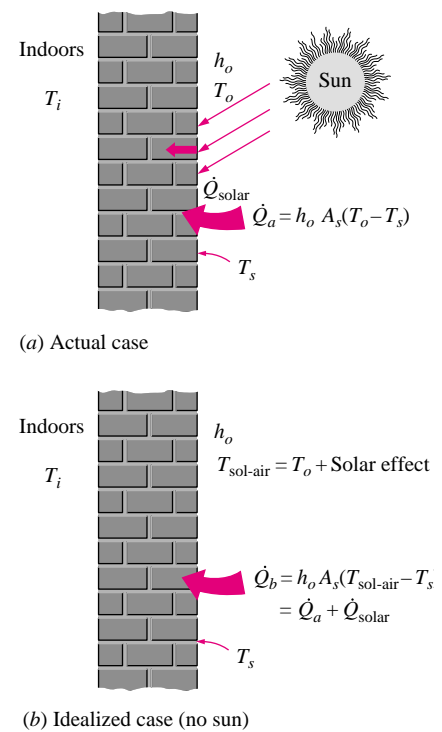
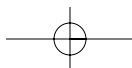

FIGURE 16-22

The sol-air temperature represents the equivalent outdoor air temperature that gives the same rate of heat flow to a surface as would the combination of incident solar radiation and convection/radiation with the environment.



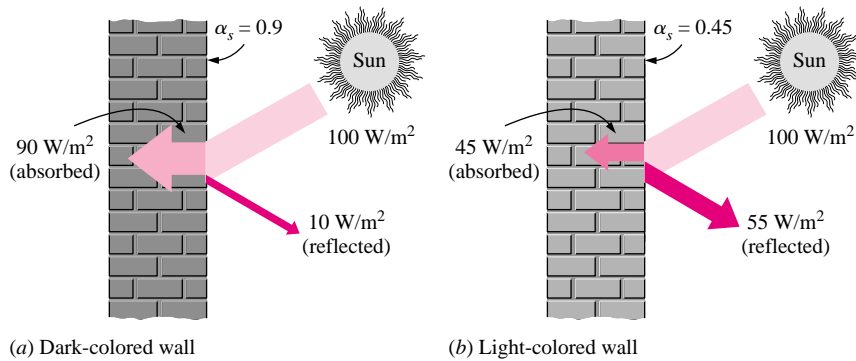
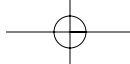

FIGURE 16-23
Dark-colored buildings absorb most of the incident solar radiation whereas light-colored ones reflect most of it.

where we have assumed conservative values of 0.45 and 0.90 for the solar absorptivities of light- and dark-colored surfaces, respectively. The sol-air temperatures for light- and dark-colored surfaces are listed in Table 16-7 for July 21 at 40° N latitude versus solar time. Sol-air temperatures for other dates and latitudes can be determined from Equation 16-16 by using appropriate temperature and incident solar radiation data.

TABLE 16-6

The reflectivity ρ_s and absorptivity α_s of common exterior surfaces for solar radiation (from Kreider and Rabl, 1994, Table 6.1)

Surface	ρ_s	α_s
<i>Natural Surfaces</i>		
Fresh snow	0.75	0.25
Soils (clay, loam, etc.)	0.14	0.86
Water	0.07	0.93
<i>Artificial Surfaces</i>		
Bituminous and gravel roof	0.13	0.87
Blacktop, old	0.10	0.90
Dark building surfaces (red brick, dark paints, etc.)	0.27	0.73
Light building surfaces (light brick, light paints, etc.)	0.60	0.40
New concrete	0.35	0.65
Old concrete	0.25	0.75
Crushed rock surface	0.20	0.80
Earth roads	0.04	0.96
<i>Vegetation</i>		
Coniferous forest (winter)	0.07	0.93
Dead leaves	0.30	0.70
Forests in autumn, ripe field crops, plants, green grass	0.26	0.74
Dry grass	0.20	0.80

Once the sol-air temperature is available, heat transfer through a wall (or similarly through a roof) can be expressed as

$$\dot{Q}_{\text{wall}} = UA_s(T_{\text{sol-air}} - T_{\text{inside}}) \quad (16-17)$$

where A_s is the wall area and U is the overall heat transfer coefficient of the wall. Therefore, the rate of heat transfer through the wall will go up by UA for each degree rise in equivalent outdoor temperature due to solar radiation. Noting that the temperature rise due to solar radiation is

$$\Delta T_{\text{solar}} = \frac{\alpha_s \dot{q}_{\text{solar}}}{h_o} \quad (16-18)$$

the rate of additional heat gain through the wall becomes

$$\dot{Q}_{\text{wall, solar}} = UA_s \Delta T_{\text{solar}} = UA_s \frac{\alpha_s \dot{q}_{\text{solar}}}{h_o} \quad (16-19)$$

The total solar radiation incident on the entire wall is $\dot{Q}_{\text{solar}} = A_s \dot{q}_{\text{solar}}$. Therefore, the fraction of incident solar heat transferred to the interior of the house is

$$\text{Solar fraction transferred} = \frac{\dot{Q}_{\text{wall, solar}}}{\dot{Q}_{\text{solar}}} = \frac{\dot{Q}_{\text{wall, solar}}}{A_s \dot{q}_{\text{solar}}} = U \frac{\alpha_s}{h_o} \quad (16-20)$$

EXAMPLE 16-3 Effect of Solar Heated Walls on Design Heat Load

The west masonry wall of a house is made of 100-mm thick red face brick, 100-mm-thick common brick, 20-mm-thick air space, and 13-mm thick gypsum board, and its overall heat transfer coefficient is 1.65 W/m² · °C, which includes the effects of convection on both the interior and exterior surfaces

TABLE 16-7

Sol-air temperatures for July 21 at 40° latitude (from ASHRAE Handbook of Fundamentals, Chap. 26, Table 1)

<i>(a) SI units</i>										
Solar time	Light-colored surface, $\alpha/h_o = 0.026 \text{ m}^2 \cdot \text{°C/W}$									
	Air temp., °C	N	NE	E	SE	S	SW	W	NW	Horiz.
5	24.0	24.1	24.2	24.2	24.1	24.0	24.0	24.0	24.0	20.1
6	24.2	27.2	34.5	35.5	29.8	25.1	25.1	25.1	25.1	22.9
7	24.8	27.3	38.1	41.5	35.2	26.5	26.4	26.4	26.4	28.1
8	25.8	28.1	38.0	43.5	38.9	28.2	28.0	28.0	28.0	33.8
9	27.2	29.9	35.9	43.1	41.2	31.5	29.8	29.8	29.8	39.2
10	28.8	31.7	33.4	40.8	41.8	35.4	31.8	31.7	31.7	43.9
11	30.7	33.7	34.0	37.4	41.1	39.0	34.2	33.7	33.7	47.7
12	32.5	35.6	35.6	35.9	39.1	41.4	39.1	35.9	35.6	50.1
13	33.8	36.8	36.8	36.8	37.3	42.1	44.2	40.5	37.1	50.8
14	34.7	37.6	37.6	37.6	37.7	41.3	47.7	46.7	39.3	49.8
15	35.0	37.7	37.6	37.6	37.6	39.3	49.0	50.9	43.7	47.0
16	34.7	37.0	36.9	36.9	36.9	37.1	47.8	52.4	46.9	42.7
17	33.9	36.4	35.5	35.5	35.5	35.6	44.3	50.6	47.2	37.2
18	32.7	35.7	33.6	33.6	33.6	33.6	38.3	44.0	43.0	31.4
19	31.3	31.4	31.3	31.3	31.3	31.3	31.4	31.5	31.5	27.4
20	29.8	29.8	29.8	29.8	29.8	29.8	29.8	29.8	29.8	25.9
Avg.	29.0	30.0	32.0	33.0	32.0	31.0	32.0	33.0	32.0	32.0

Solar time	Dark-colored surface, $\alpha/h_o = 0.052 \text{ m}^2 \cdot \text{°C/W}$									
	Air temp., °C	N	NE	E	SE	S	SW	W	NW	Horiz.
5	24.0	24.2	24.4	24.3	24.1	24.0	24.0	24.0	24.0	20.2
6	24.2	30.2	44.7	46.7	35.4	26.0	26.0	26.0	26.0	25.5
7	24.8	29.7	51.5	58.2	45.6	28.2	28.0	28.0	28.0	35.4
8	25.8	30.5	50.1	61.2	52.1	30.7	30.1	30.1	30.1	45.8
9	27.2	32.5	44.5	58.9	55.1	35.8	32.3	32.3	32.3	55.1
10	28.8	34.5	38.0	52.8	54.9	42.0	34.7	34.5	34.5	62.8
11	30.7	36.8	37.2	44.0	51.5	47.4	37.7	36.8	36.8	68.5
12	32.5	38.7	38.7	39.3	45.7	50.4	45.7	39.3	38.7	71.6
13	33.8	39.9	39.9	39.9	40.8	50.5	54.6	47.1	40.3	71.6
14	34.7	40.4	40.4	40.4	40.6	47.9	60.8	58.7	43.9	68.7
15	35.0	40.3	40.1	40.1	40.1	43.6	62.9	66.7	52.3	62.9
16	34.7	39.4	39.0	39.0	39.0	39.6	61.0	70.1	59.0	54.7
17	33.9	38.8	37.1	37.1	37.1	37.3	54.7	67.3	60.6	44.5
18	32.7	38.7	34.5	34.5	34.5	34.5	43.9	55.2	53.2	34.0
19	31.3	31.5	31.3	31.3	31.3	31.3	31.4	31.6	31.7	27.5
20	29.8	29.8	29.8	29.8	29.8	29.8	29.8	29.8	29.8	25.9
Avg.	29.0	32.0	35.0	37.0	37.0	34.0	37.0	37.0	35.0	40.0

<i>(b) English units</i>										
Solar time	Light-colored surface, $\alpha/h_o = 0.15 \text{ h} \cdot \text{ft} \cdot \text{°F/Btu}$									
	Air temp., °F	N	NE	E	SE	S	SW	W	NW	Horiz.
5	74	74	74	74	74	74	74	74	74	67
6	74	80	93	95	84	76	76	76	76	72
7	75	80	99	106	94	78	78	78	78	81
8	77	81	99	109	101	82	81	81	81	92
9	80	85	96	109	106	88	85	85	85	102
10	83	88	91	105	107	95	88	88	88	111
11	87	93	93	99	106	102	93	93	93	118
12	90	96	96	96	102	106	102	96	96	122
13	93	99	99	99	99	108	112	105	99	124
14	94	99	99	99	99	106	118	116	102	122
15	95	100	100	100	100	103	121	124	111	117
16	94	98	98	98	98	99	118	126	116	109
17	93	98	96	96	96	96	112	124	117	99
18	91	97	93	93	93	93	101	112	110	89
19	87	87	87	87	87	87	87	87	87	80
20	85	85	85	85	85	85	85	85	85	78
Avg.	83	86	88	90	90	87	90	90	88	90

Solar time	Dark-colored surface, $\alpha/h_o = 0.30 \text{ h} \cdot \text{ft}^2 \cdot \text{°F/Btu}$									
	Air temp., °F	N	NE	E	SE	S	SW	W	NW	Horiz.
5	74	74	75	75	74	74	74	74	74	67
6	74	85	112	115	94	77	77	77	77	77
7	75	84	124	136	113	81	81	81	81	94
8	77	85	121	142	125	86	85	85	85	114
9	80	90	112	138	131	96	89	89	89	131
10	83	94	100	127	131	107	94	94	94	145
11	87	98	99	111	125	118	100	98	98	156
12	90	101	101	102	114	123	114	102	101	162
13	93	104	104	104	106	124	131	117	105	162
14	94	105	105	105	105	118	142	138	111	156
15	95	105	104	104	104	111	146	153	127	146
16	94	102	102	102	102	103	142	159	138	131
17	93	102	99	99	99	99	131	154	142	112
18	91	102	94	94	94	94	111	132	129	94
19	87	87	87	87	87	87	87	88	88	80
20	85	85	85	85	85	85	85	85	85	78
Avg.	83	89	94	99	97	93	97	99	94	104

Note: Sol-air temperatures are calculated based on a radiation correction of 7°F (3.9°C) for horizontal surfaces and 0°F (0°C) for vertical surfaces.



16-20
HEATING AND COOLING OF BUILDINGS

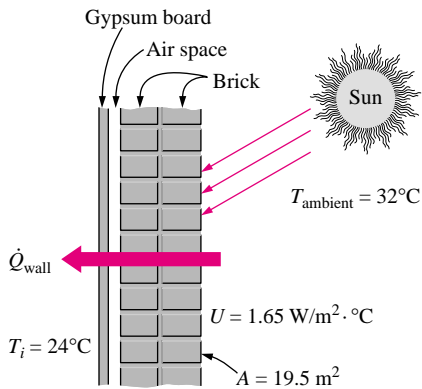

FIGURE 16-24
Schematic for Example 16-3.

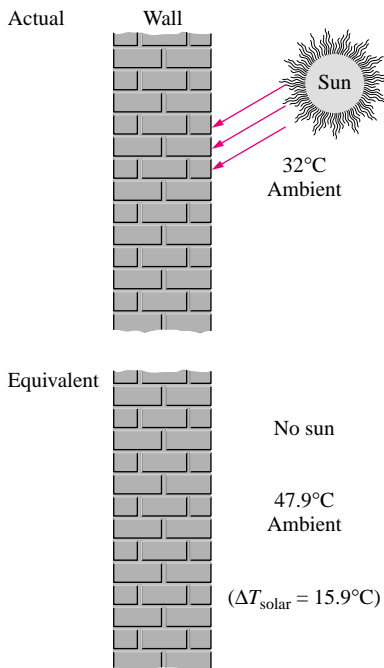

FIGURE 16-25
The difference between the sol-air temperature and the ambient air temperature represents the equivalent temperature rise of ambient air due to solar heating.

(Fig. 16-24). The house is located at 40°N latitude, and its cooling system is to be sized on the basis of the heat gain at 15:00 hour (3 PM) solar time on July 21. The interior of the house is to be maintained at 24°C, and the exposed surface area of the wall is 19.5 m². If the design ambient air temperature at that time at that location is 32°C, determine (a) the design heat gain through the wall, (b) the fraction of this heat gain due to solar heating, and (c) the fraction of incident solar radiation transferred into the house through the wall.

SOLUTION The west wall of a house is subjected to solar radiation at summer design conditions. The design heat gain, the fraction of heat gain due to solar heating, and the fraction of solar radiation that is transferred to the house are to be determined.

Assumptions 1 Steady conditions exist. 2 Thermal properties of the wall and the heat transfer coefficients are constant.

Properties The overall heat transfer coefficient of the wall is given to be 1.65 W/m² · °C.

Analysis (a) The house is located at 40°N latitude, and thus we can use the sol-air temperature data directly from Table 16-7. At 15:00 the tabulated air temperature is 35°C, which is 3°C higher than the air temperature given in the problem. But we can still use the data in that table provided that we subtract 3°C from all temperatures. Therefore, the sol-air temperature on the west wall in this case is 50.9 – 3 = 47.9°C, and the heat gain through the wall is determined to be

$$\begin{aligned} \dot{Q}_{\text{wall}} &= UA_s(T_{\text{sol-air}} - T_{\text{inside}}) \\ &= (1.65 \text{ W/m}^2 \cdot \text{°C})(19.5 \text{ m}^2)(47.9 - 24)\text{°C} = \mathbf{769 \text{ W}} \end{aligned}$$

(b) Heat transfer is proportional to the temperature difference, and the overall temperature difference in this case is 47.9 – 24 = 23.9°C. Also, the difference between the sol-air temperature and the ambient air temperature is (Fig. 16-25)

$$\Delta T_{\text{solar}} = T_{\text{sol-air}} - T_{\text{ambient}} = (47.9 - 32)\text{°C} = 15.9\text{°C}$$

which is the equivalent temperature rise of the ambient air due to solar heating. The fraction of heat gain due to solar heating is equal to the ratio of the solar temperature difference to the overall temperature difference, and is determined to be

$$\text{Solar fraction} = \frac{\dot{Q}_{\text{wall, solar}}}{\dot{Q}_{\text{wall, total}}} = \frac{UA_s \Delta T_{\text{solar}}}{UA_s \Delta T_{\text{total}}} = \frac{\Delta T_{\text{solar}}}{\Delta T_{\text{total}}} = \frac{15.9\text{°C}}{23.9\text{°C}} = \mathbf{0.67 \text{ (or 67\%)}}$$

Therefore, two-thirds of the heat gain through the west wall in this case is due to solar heating of the wall.

(c) The outer layer of the wall is made of red brick, which is dark colored. Therefore, the value of α_s/h_o is 0.052 m² · °C/W. Then the fraction of incident solar energy transferred to the interior of the house is determined directly from Equation 16-20 to be.

$$\begin{aligned} \text{Solar fraction transferred} &= U \frac{\alpha_s}{h_o} = (1.65 \text{ W/m}^2 \cdot \text{°C})(0.052 \text{ m}^2 \cdot \text{°C/W}) \\ &= \mathbf{0.086} \end{aligned}$$

Therefore, less than 10 percent of the solar energy incident on the surface will be transferred to the house. Note that a glass wall would transmit about 10 times more energy into the house.

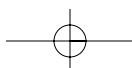

16-5 ■ HEAT GAIN FROM PEOPLE, LIGHTS, AND APPLIANCES

The conversion of chemical or electrical energy to thermal energy in a building constitutes the **internal heat gain** or **internal load** of a building. The primary sources of internal heat gain are people, lights, appliances, and miscellaneous equipment such as computers, printers, and copiers (Fig. 16-26). Internal heat gain is usually ignored in *design heating load* calculations to ensure that the heating system can do the job even when there is no heat gain, but it is always considered in *design cooling load* calculations since the internal heat gain usually constitutes a significant fraction of it.

People

The average amount of heat given off by a person depends on the level of activity, and can range from about 100 W for a resting person to more than 500 W for a physically very active person. Typical rates of heat dissipation by people are given in Table 16-8 for various activities in various application areas. Note that *latent heat* constitutes about one-third of the total heat dissipated during resting, but rises to almost two-thirds the level during heavy

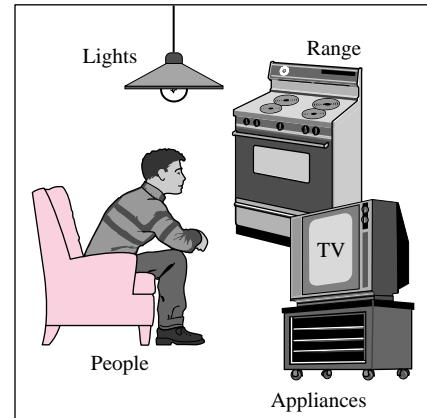

FIGURE 16-26
The heat given off by people, lights, and equipment represents the internal heat gain of a building.

TABLE 16-8

Heat gain from people in conditioned spaces (from ASHRAE *Handbook of Fundamentals*, Chap. 26, Table 3)

Degree of activity	Typical application	Total heat, W			
		Adult male	Adjusted M/F/C ¹	Sensible heat, W	Latent heat, W
Seated at theater	Theater—matinee	115	95	65	30
Seated at theater, night	Theater—evening	115	105	70	35
Seated, very light work	Offices, hotels, apartments	130	115	70	45
Moderately active office work	Offices, hotels, apartments	140	130	75	55
Standing, light work; walking	Department or retail store	160	130	75	55
Walking, standing	Drug store, bank	160	145	75	70
Sedentary work	Restaurant ²	145	160	80	80
Light bench work	Factory	235	220	80	80
Moderate dancing	Dance hall	265	250	90	90
Walking 4.8 km/h; light machine work	Factory	295	295	110	110
Bowling ³	Bowling alley	440	425	170	255
Heavy work	Factory	440	425	170	255
Heavy machine work; lifting	Factory	470	470	185	285
Athletics	Gymnasium	585	525	210	315

Note: Tabulated values are based on a room temperature of 24°C. For a room temperature of 27°C, the total heat gain remains the same but the sensible heat values should be decreased by about 20 percent, and the latent heat values should be increased accordingly. All values are rounded to nearest 5 W. The fraction of sensible heat that is radiant ranges from 54 to 60 percent in calm air ($V < 0.2$ m/s) and from 19 to 38 percent in moving air ($0.2 < V < 4$ m/s).

¹Adjusted heat gain is based on normal percentage of men, women, and children for the application listed, with the postulate that the gain from an adult female is 85 percent of that for an adult male and that the gain from a child is 75 percent of that for an adult male.

²Adjusted heat gain includes 18 W for food per individual (9 W sensible and 9 W latent).

³Figure one person per alley actually bowling, and all others are sitting (117 W) or standing or walking slowly (231 W).

16-22
HEATING AND COOLING OF BUILDINGS

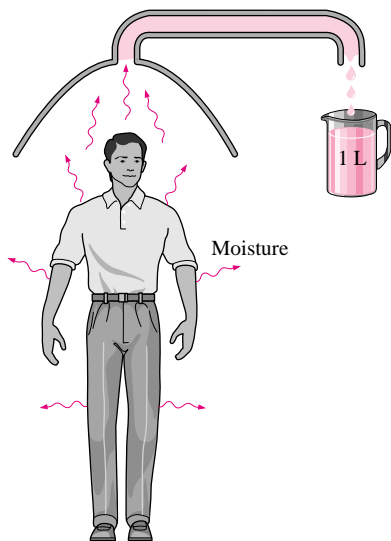

FIGURE 16-27

If the moisture leaving an average resting person's body in one day were collected and condensed it would fill a 1-L container.

physical work. Also, about 30 percent of the sensible heat is lost by convection and the remaining 70 percent by radiation. The *latent* and *convective* sensible heat losses represent the “instant” cooling load for people since they need to be removed immediately. The *radiative sensible heat*, on the other hand, is first absorbed by the surrounding surfaces and then released gradually with some delay.

It is interesting to note that an average person dissipates latent heat at a minimum rate of 30 W while resting. Noting that the enthalpy of vaporization of water at 33°C is 2424 kJ/kg, the amount of water an average person loses a day by evaporation at the skin and the lungs is (Fig. 16-27)

$$\begin{aligned} \text{Daily Water loss} &= \frac{\text{Latent heat loss per day}}{\text{Heat of vaporization}} \\ &= \frac{(0.030 \text{ kJ/s})(24 \times 3600 \text{ s/day})}{2424 \text{ kJ/kg}} = 1.07 \text{ kg/day} \end{aligned}$$

which justifies the sound advice that a person must drink at least 1 L of water every day. Therefore, a family of four will supply 4 L of water a day to the air in the house while just resting. This amount will be much higher during heavy work.

Heat given off by people usually constitutes a significant fraction of the sensible and latent heat gain of a building, and may dominate the cooling load in high occupancy buildings such as theaters and concert halls. The rate of heat gain from people given in Table 16-8 is quite accurate, but there is considerable uncertainty in the internal load due to people because of the difficulty in predicting the number of occupants in a building at any given time. The design cooling load of a building should be determined assuming full occupancy. In the absence of better data, the number of occupants can be estimated on the basis of one occupant per 1 m² in auditoriums, 2.5 m² in schools, 3–5 m² in retail stores, and 10–15 m² in offices.

Lights

Lighting constitutes about 7 percent of the total energy use in residential buildings and 25 percent in commercial buildings. Therefore, lighting can have a significant impact on the heating and cooling loads of a building. Not counting the candle light used for emergencies and romantic settings, and the kerosene lamps used during camping, all modern lighting equipment is powered by electricity. The basic types of electric lighting devices are incandescent, fluorescent, and gaseous discharge lamps.

The amount of heat given off per lux of lighting varies greatly with the type of lighting, and thus we need to know the type of lighting installed in order to predict the lighting internal heat load accurately. The lighting efficacy of common types of lighting is given in Table 16-9. Note that incandescent lights are the least efficient lighting sources, and thus they will impose the greatest load on cooling systems (Fig. 16-28). So it is no surprise that practically all office buildings use high-efficiency fluorescent lights despite their higher initial cost. Note that incandescent lights waste energy by (1) consuming more electricity for the same amount of lighting and (2) making the cooling system work harder and longer to remove the heat given off. Office spaces are usually well lit, and the lighting energy consumption in office buildings is about 20 to 30 W/m² of floor space.

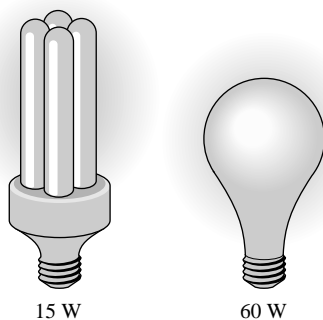

FIGURE 16-28

A 15-W compact fluorescent lamp provides as much light as a 60-W incandescent lamp.

TABLE 16-9

Comparison of different lighting systems

Type of lighting	Efficacy, lumens/W	Life, h	Comments
<i>Combustion</i>			
Candle	0.2	10	Very inefficient. Best for emergencies.
<i>Incandescent</i>			
Ordinary	5–20	1000	Low initial cost; low efficiency.
Halogen	15–25	2000	Better efficiency; excellent color rendition.
<i>Fluorescent</i>			
Ordinary	40–60	10,000	Being replaced by high-output types.
High output	70–90	10,000	Commonly in offices and plants.
Compact	50–80	10,000	Fits into the sockets of incandescent lights.
Metal halide	55–125		High efficiency; good color rendition.
<i>Gaseous Discharge</i>			
Mercury vapor	50–60	10,000	Both indoor and outdoor use.
High-pressure sodium	100–150	15,000	Good color rendition. Indoor and outdoor use.
Low-pressure sodium	up to 200		Distinct yellow light. Best for outdoor use.

The energy consumed by the lights is dissipated by convection and radiation. The convection component of the heat constitutes about 40 percent for fluorescent lamps, and it represents the instantaneous part of the cooling load due to lighting. The remaining part is in the form of radiation that is absorbed and reradiated by the walls, floors, ceiling, and the furniture, and thus they affect the cooling load with time delay. Therefore, lighting may continue contributing to the cooling load by reradiation even after the lights have been turned off. Sometimes it may be necessary to consider time lag effects when determining the design cooling load.

The ratio of the lighting wattage in use to the total wattage installed is called the **usage factor**, and it must be considered when determining the heat gain due to lighting at a given time since installed lighting does not give off heat unless it is on. For commercial applications such as supermarkets and shopping centers, the usage factor is taken to be unity.

Equipment and Appliances

Most equipment and appliances are driven by electric motors, and thus the heat given off by an appliance in steady operation is simply the power consumed by its motor. For a fan, for example, part of the power consumed by the motor is transmitted to the fan to drive it, while the rest is converted to heat because of the inefficiency of the motor. The fan transmits the energy to the air molecules and increases their kinetic energy. But this energy is also converted to heat as the fast-moving molecules are slowed down by other molecules and stopped as a result of friction. Therefore, we can say that the entire energy consumed by the motor of the fan in a room is eventually converted to heat in that room. Of course, if the motor is in one room (say, room A) and the fan is in another (say, room B), then the heat gain of room B will be equal to the power transmitted to the fan only, while the heat gain of room A will be the heat generated by the motor due to its inefficiency (Fig. 16-29).

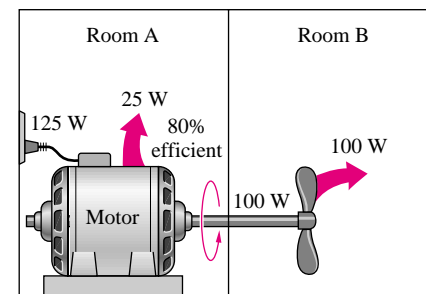

FIGURE 16-29

An 80 percent efficient motor that drives a 100-W fan contributes 25 W and 100 W to the heat loads of the motor and equipment rooms, respectively.

The power rating \dot{W}_{motor} on the label of a motor represents the power that the motor will supply under full load conditions. But a motor usually operates at part load, sometimes at as low as 30 to 40 percent, and thus it consumes and delivers much less power than the label indicates. This is characterized by the **load factor** f_{load} of the motor during operation, which is $f_{\text{load}} = 1.0$ for full load. Also, there is an inefficiency associated with the conversion of electrical energy to rotational mechanical energy. This is characterized by the **motor efficiency** η_{motor} , which decreases with decreasing load factor. Therefore, it is not a good idea to oversize the motor since oversized motors operate at a low load factor and thus at a lower efficiency. Another factor that affects the amount of heat generated by a motor is how long a motor actually operates. This is characterized by the **usage factor** f_{usage} , with $f_{\text{usage}} = 1.0$ for continuous operation. Motors with very low usage factors such as the motors of dock doors can be ignored in calculations. Then the heat gain due to a motor inside a conditioned space can be expressed as

$$\dot{Q}_{\text{motor, total}} = \dot{W}_{\text{motor}} \times f_{\text{load}} \times f_{\text{usage}} / \eta_{\text{motor}} \quad (\text{W}) \quad (16-21)$$

Heat generated in conditioned spaces by electric, gas, and steam appliances such as a range, refrigerator, freezer, TV, dishwasher, clothes washer, drier, computers, printers, and copiers can be significant, and thus must be considered when determining the peak cooling load of a building. There is considerable uncertainty in the estimated heat gain from appliances owing to the variations in appliances and the varying usage schedules. The exhaust hoods in the kitchen complicate things further. Also, some office equipment such as printers and copiers consume considerable power in the standby mode. A 350-W laser printer, for example, may consume 175 W and a 600-W computer may consume 530 W when in standby mode.

The heat gain from office equipment in a typical office with computer terminals on most desks can be up to 47 W/m². This value can be 10 times as large for computer rooms that house mainframe computers. When the equipment inventory of a building is known, the equipment heat gain can be determined more accurately using the data given in the ASHRAE *Handbook of Fundamentals*.

The presence of thermostatic controls and typical usage practices make it highly unlikely for all the appliances in a conditioned space to operate at full load. A more realistic approach is to take 50 percent of the total nameplate ratings of the appliances to represent the maximum use. Therefore, the peak heat gain from appliances is taken to be

$$\dot{Q}_{\text{unhooded appliance}} = 0.5 \dot{Q}_{\text{appliance, input}} \quad (\text{W}) \quad (16-22)$$

regardless of the type of energy or fuel used. For cooling load estimate, about 34 percent of heat gain can be assumed to be latent heat, with the remaining 66 percent to be sensible in this case.

In hooded appliances, the air heated by convection and the moisture generated are removed by the hood. Therefore, the only heat gain from hooded appliances is radiation, which constitutes up to 32 percent of the energy consumed by the appliance (Fig. 16-30). Therefore, the design value of heat gain from hooded electric or steam appliances is simply half of this 32 percent.

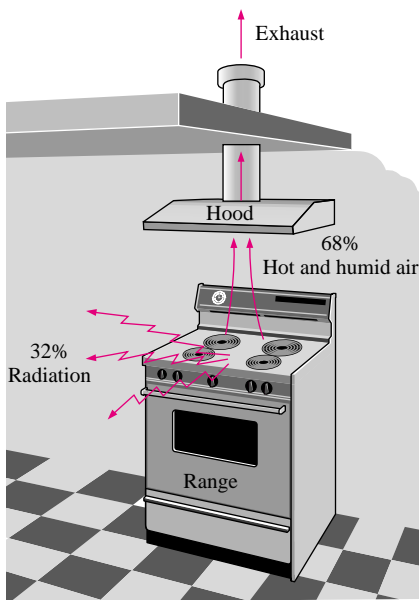

FIGURE 16-30

In hooded appliances, about 68 percent of the generated heat is vented out with the heated and humidified air.



EXAMPLE 16-4 Energy Consumption of Electric and Gas Burners

The efficiency of cooking equipment affects the internal heat gain from them since an inefficient appliance consumes a greater amount of energy for the same task, and the excess energy consumed shows up as heat in the living space. The efficiency of open burners is determined to be 73 percent for electric units and 38 percent for gas units (Fig. 16-31). Consider a 2-kW unhooded electric open burner in an area where the unit costs of electricity and natural gas are \$0.09/kWh and \$0.55/therm (1 therm = 29.3 kWh), respectively. Determine the amount of electrical energy used directly for cooking, the cost of energy per “utilized” kWh, and the contribution of this burner to the design cooling load. Repeat the calculations for the gas burner.

SOLUTION The efficiency of the electric heater is given to be 73 percent. Therefore, a burner that consumes 2 kW of electrical energy will supply

$$\dot{Q}_{\text{utilized}} = (\text{Energy input}) \times (\text{Efficiency}) = (2 \text{ kW})(0.73) = \mathbf{1.46 \text{ kW}}$$

of useful energy. The unit cost of utilized energy is inversely proportional to the efficiency and is determined from

$$\text{Cost of utilized energy} = \frac{\text{Cost of energy input}}{\text{Efficiency}} = \frac{\$0.09/\text{kWh}}{0.73} = \mathbf{\$0.123/\text{kWh}}$$

The design heat gain from an unhooded appliance is taken to be half of its rated energy consumption and is determined to be

$$\begin{aligned} \dot{Q}_{\text{unhooded appliance}} &= 0.5\dot{Q}_{\text{appliance, input}} \\ &= 0.5 \times (2 \text{ kW}) = \mathbf{1 \text{ kW}} \quad (\text{electric burner}) \end{aligned}$$

Noting that the efficiency of a gas burner is 38 percent, the energy input to a gas burner that supplies utilized energy at the same rate (1.46 kW) is

$$\dot{Q}_{\text{input, gas}} = \frac{\dot{Q}_{\text{utilized}}}{\text{Efficiency}} = \frac{1.46 \text{ kW}}{0.38} = \mathbf{3.84 \text{ kW}}$$

Therefore, a gas burner should have a rating of at least 3.84 kW to perform as well as the electric unit.

Noting that 1 therm = 29.3 kWh, the unit cost of utilized energy in the case of a gas burner is determined similarly to be

$$\begin{aligned} \text{Cost of utilized energy} &= \frac{\text{Cost of energy input}}{\text{Efficiency}} = \frac{\$0.55/(29.3 \text{ kWh})}{0.38} \\ &= \mathbf{\$0.049/\text{kWh}} \end{aligned}$$

which is about one-quarter of the unit cost of utilized electricity. Therefore, despite its higher efficiency, cooking with an electric burner will cost four times as much compared to a gas burner in this case. This explains why cost-conscious consumers always ask for gas appliances, and it is not wise to use electricity for heating purposes.

Finally, the design heat gain from this unhooded gas burner is determined to be

$$\begin{aligned} \dot{Q}_{\text{unhooded appliance}} &= 0.5\dot{Q}_{\text{appliance, input}} \\ &= 0.5 \times (3.84 \text{ kW}) = \mathbf{1.92 \text{ kW}} \quad (\text{gas burner}) \end{aligned}$$

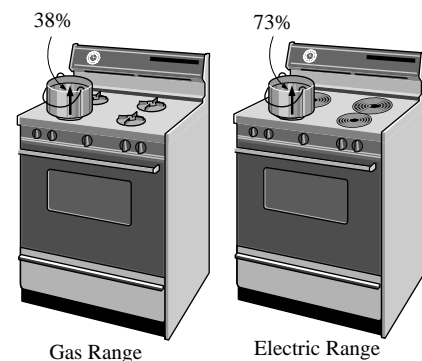
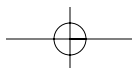
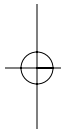

FIGURE 16-31
Schematic of the 73 percent efficient electric heating unit and 38 percent efficient gas burner discussed in Example 16-4.



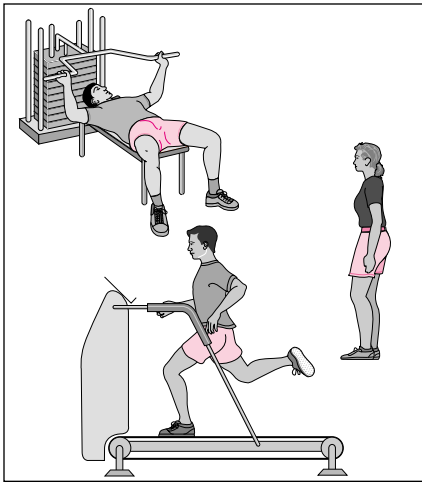
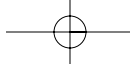

FIGURE 16-32
Schematic for Example 16-5.

TABLE 16-11

Combined convection and radiation heat transfer coefficients at window, wall, or roof surfaces (from ASHRAE Handbook of Fundamentals, Chap. 22, Table 1)

		$h, \text{W/m}^2 \cdot ^\circ\text{C}$		
Position	Direction of heat flow	Surface emittance, ϵ		
		0.90	0.20	0.05
<i>Still Air (both indoors and outdoors)</i>				
Horiz.	Up \uparrow	9.26	5.17	4.32
Horiz.	Down \downarrow	6.13	2.10	1.25
45° slope	Up \uparrow	9.09	5.00	4.15
45° slope	Down \downarrow	7.50	3.41	2.56
Vertical	Horiz. \rightarrow	8.29	4.20	3.35
<i>Moving Air (any position, any direction)</i>				
Winter condition				
	(winds at 24 km/h)	34.0	—	—
Summer condition				
	(winds at 12 km/h)	22.7	—	—

Surface resistance can be obtained from $R = 1/h$.

which is 92 percent larger than that of the electric burner. Therefore, an unhooded gas appliance will contribute more to the heat gain than a comparable electric appliance.

EXAMPLE 16-5 Heat Gain of an Exercise Room

An exercise room has 10 weight-lifting machines that have no motors and 7 treadmills each equipped with a 2-hp motor (Fig. 16-32). The motors operate at an average load factor of 0.6, at which their efficiency is 0.75. During peak evening hours, 17 pieces of exercising equipment are used continuously, and there are also four people doing light exercises while waiting in line for one piece of the equipment. Determine the rate of heat gain of the exercise room from people and the equipment at peak load conditions. How much of this heat gain is in the latent form?

SOLUTION The 10 weight-lifting machines do not have any motors, and thus they do not contribute to the internal heat gain directly. The usage factors of the motors of the treadmills are taken to be unity since they are used constantly during peak periods. Noting that 1 hp = 746 W, the total heat generated by the motors is

$$\dot{Q}_{\text{motors}} = (\text{No. of motors}) \times \dot{W}_{\text{motor}} \times f_{\text{load}} \times f_{\text{usage}} / \eta_{\text{motor}}$$

$$= 7 \times (2 \times 746 \text{ W}) \times 0.60 \times 1.0 / 0.75 = 8355 \text{ W}$$

The average rate of heat dissipated by people in an exercise room is given in Table 16-8 to be 525 W, of which 315 W is in latent form. Therefore, the heat gain from 21 people is

$$\dot{Q}_{\text{people}} = (\text{No. of people}) \times \dot{Q}_{\text{person}} = 21 \times (525 \text{ W}) = \mathbf{11,025 \text{ W}}$$

Then the total rate of heat gain (or the internal heat load) of the exercise room during peak period becomes

$$\dot{Q}_{\text{total}} = \dot{Q}_{\text{motors}} + \dot{Q}_{\text{people}} = 8355 + 11,025 = \mathbf{19,380 \text{ W}}$$

The entire heat given off by the motors is in sensible form. Therefore, the latent heat gain is due to people only, which is determined to be

$$\dot{Q}_{\text{latent}} = (\text{No. of people}) \times \dot{Q}_{\text{latent, per person}} = 21 \times (315 \text{ W}) = \mathbf{6615 \text{ W}}$$

The remaining 12,765 W of heat gain is in the sensible form.

16-6 HEAT TRANSFER THROUGH WALLS AND ROOFS

Under steady conditions, the rate of heat transfer through any section of a building wall or roof can be determined from

$$\dot{Q} = UA_s(T_i - T_o) = \frac{A_s(T_i - T_o)}{R} \tag{16-23}$$

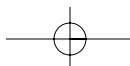

where T_i and T_o are the indoor and outdoor air temperatures, A_s is the heat transfer area, U is the overall heat transfer coefficient (the U -factor), and $R = 1/U$ is the overall unit thermal resistance (the R -value). Walls and roofs of buildings consist of various layers of materials, and the structure and operating conditions of the walls and the roofs may differ significantly from one building to another. Therefore, it is not practical to list the R -values (or U -factors) of different kinds of walls or roofs under different conditions. Instead, the overall R -value is determined from the thermal resistances of the individual components using the thermal resistance network. The overall thermal resistance of a structure can be determined most accurately in a lab by actually assembling the unit and testing it as a whole, but this approach is usually very time consuming and expensive. The analytical approach described here is fast and straightforward, and the results are usually in good agreement with the experimental values.

The unit thermal resistance of a plane layer of thickness L and thermal conductivity k can be determined from $R = L/k$. The thermal conductivity and other properties of common building materials are given in the appendix. The unit thermal resistances of various components used in building structures are listed in Table 16–10 for convenience.

Heat transfer through a wall or roof section is also affected by the convection and radiation heat transfer coefficients at the exposed surfaces. The effects of convection and radiation on the inner and outer surfaces of walls and

TABLE 16–10

Unit thermal resistance (the R -value) of common components used in buildings

Component	R -Value		Component	R -Value	
	$m^2 \cdot ^\circ C/W$	$ft^2 \cdot h \cdot ^\circ F/Btu$		$m^2 \cdot ^\circ C/W$	$ft^2 \cdot h \cdot ^\circ F/Btu$
Outside surface (winter)	0.030	0.17	Wood stud, nominal 2 in \times 6 in (5.5 in or 140 mm wide)	0.98	5.56
Outside surface (summer)	0.044	0.25	Clay tile, 100 mm (4 in)	0.18	1.01
Inside surface, still air	0.12	0.68	Acoustic tile	0.32	1.79
Plane air space, vertical, ordinary surfaces ($\epsilon_{\text{eff}} = 0.82$):			Asphalt shingle roofing	0.077	0.44
13 mm ($\frac{1}{2}$ in)	0.16	0.90	Building paper	0.011	0.06
20 mm ($\frac{3}{4}$ in)	0.17	0.94	Concrete block, 100 mm (4 in):		
40 mm (1.5 in)	0.16	0.90	Lightweight	0.27	1.51
90 mm (3.5 in)	0.16	0.91	Heavyweight	0.13	0.71
Insulation, 25 mm (1 in)			Plaster or gypsum board, 13 mm ($\frac{1}{2}$ in)	0.079	0.45
Glass fiber	0.70	4.00	Wood fiberboard, 13 mm ($\frac{1}{2}$ in)	0.23	1.31
Mineral fiber batt	0.66	3.73	Plywood, 13 mm ($\frac{1}{2}$ in)	0.11	0.62
Urethane rigid foam	0.98	5.56	Concrete, 200 mm (8 in)		
Stucco, 25 mm (1 in)	0.037	0.21	Lightweight	1.17	6.67
Face brick, 100 mm (4 in)	0.075	0.43	Heavyweight	0.12	0.67
Common brick, 100 mm (4 in)	0.12	0.79	Cement mortar, 13 mm (1/2 in)	0.018	0.10
Steel siding	0.00	0.00	Wood bevel lapped siding, 13 mm \times 200 mm (1/2 in \times 8 in)	0.14	0.81
Slag, 13 mm ($\frac{1}{2}$ in)	0.067	0.38			
Wood, 25 mm (1 in)	0.22	1.25			
Wood stud, nominal 2 in \times 4 in (3.5 in or 90 mm wide)	0.63	3.58			

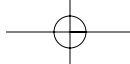

roofs are usually combined into the *combined convection and radiation heat transfer coefficients* (also called *surface conductances*) h_i and h_o , respectively, whose values are given in Table 16–11 for ordinary surfaces ($\epsilon = 0.9$) and reflective surfaces ($\epsilon = 0.2$ or 0.05). Note that surfaces having a low emittance also have a low surface conductance due to the reduction in radiation heat transfer. The values in the table are based on a surface temperature of 21°C and a surface–air temperature difference of 5.5°C . Also, the equivalent surface temperature of the environment is assumed to be equal to the ambient air temperature. Despite the convenience it offers, this assumption is not quite accurate because of the additional radiation heat loss from the surface to the clear sky. The effect of sky radiation can be accounted for approximately by taking the outside temperature to be the average of the outdoor air and sky temperatures.

The inner surface heat transfer coefficient h_i remains fairly constant throughout the year, but the value of h_o varies considerably because of its dependence on the orientation and wind speed, which can vary from less than 1 km/h in calm weather to over 40 km/h during storms. The commonly used values of h_i and h_o for peak load calculations are

$$h_i = 8.29 \text{ W/m}^2 \cdot ^\circ\text{C} \quad (\text{winter and summer})$$

$$h_o = \begin{cases} 34.0 \text{ W/m}^2 \cdot ^\circ\text{C} & (\text{winter}) \\ 22.7 \text{ W/m}^2 \cdot ^\circ\text{C} & (\text{summer}) \end{cases}$$

which correspond to design wind conditions of 24 km/h for winter and 12 km/h for summer. The corresponding surface thermal resistances (R -values) are determined from $R_i = 1/h_i$ and $R_o = 1/h_o$. The surface conductance values under still air conditions can be used for interior surfaces as well as exterior surfaces in calm weather.

Building components often involve *trapped air spaces* between various layers. Thermal resistances of such air spaces depend on the thickness of the layer, the temperature difference across the layer, the mean air temperature, the emissivity of each surface, the orientation of the air layer, and the direction of heat transfer. The emissivities of surfaces commonly encountered in buildings are given in Table 16–12. The **effective emissivity** of a plane-parallel air space is given by

$$\frac{1}{\epsilon_{\text{effective}}} = \frac{1}{\epsilon_1} + \frac{1}{\epsilon_2} - 1 \quad (16-24)$$

where ϵ_1 and ϵ_2 are the emissivities of the surfaces of the air space. Table 16–12 also lists the effective emissivities of air spaces for the cases where (1) the emissivity of one surface of the air space is ϵ while the emissivity of the other surface is 0.9 (a building material) and (2) the emissivity of both surfaces is ϵ . Note that the effective emissivity of an air space between building materials is $0.82/0.03 = 27$ times that of an air space between surfaces covered with aluminum foil. For specified surface temperatures, radiation heat transfer through an air space is proportional to effective emissivity, and thus the rate of radiation heat transfer in the ordinary surface case is 27 times that of the reflective surface case.

Table 16–13 lists the thermal resistances of 20-mm-, 40-mm-, and 90-mm-thick air spaces under various conditions. The thermal resistance values in the

TABLE 16–12

Emissivities ϵ of various surfaces and the effective emissivity of air spaces (from ASHRAE *Handbook of Fundamentals*, Chap. 22, Table 3).

Surface	Effective Emissivity of Air Space		
	ϵ	$\epsilon_1 = \epsilon$ $\epsilon_2 = 0.9$	$\epsilon_1 = \epsilon$ $\epsilon_2 = \epsilon$
Aluminum foil, bright	00.5*	0.05	0.03
Aluminum sheet	0.12	0.12	0.06
Aluminum-coated paper, polished	0.20	0.20	0.11
Steel, galvanized, bright	0.25	0.24	0.15
Aluminum paint	0.50	0.47	0.35
Building materials: Wood, paper, masonry, nonmetallic paints	0.90	0.82	0.82
Ordinary glass	0.84	0.77	0.72

*Surface emissivity of aluminum foil increases to 0.30 with barely visible condensation, and to 0.70 with clearly visible condensation.

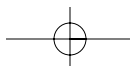

TABLE 16-13

Unit thermal resistances (*R*-values) of well-sealed plane air spaces (from ASHRAE *Handbook of Fundamentals*, Chap. 22, Table 2)

(a) SI units (in m² · °C/W)

Position of Air Space	Direction of Heat Flow	Mean Temp., °C	Temp. Diff., °C	20-mm Air Space				40-mm Air Space				90-mm Air Space			
				Effective Emissivity, ϵ_{eff}				Effective Emissivity, ϵ_{eff}				Effective Emissivity, ϵ_{eff}			
				0.03	0.05	0.5	0.82	0.03	0.05	0.5	0.82	0.03	0.05	0.5	0.82
Horizontal Up ↑		32.2	5.6	0.41	0.39	0.18	0.13	0.45	0.42	0.19	0.14	0.50	0.47	0.20	0.14
		10.0	16.7	0.30	0.29	0.17	0.14	0.33	0.32	0.18	0.14	0.27	0.35	0.19	0.15
		10.0	5.6	0.40	0.39	0.20	0.15	0.44	0.42	0.21	0.16	0.49	0.47	0.23	0.16
		-17.8	11.1	0.32	0.32	0.20	0.16	0.35	0.34	0.22	0.17	0.40	0.38	0.23	0.18
45° slope Up ↑		32.2	5.6	0.52	0.49	0.20	0.14	0.51	0.48	0.20	0.14	0.56	0.52	0.21	0.14
		10.0	16.7	0.35	0.34	0.19	0.14	0.38	0.36	0.20	0.15	0.40	0.38	0.20	0.15
		10.0	5.6	0.51	0.48	0.23	0.17	0.51	0.48	0.23	0.17	0.55	0.52	0.24	0.17
		-17.8	11.1	0.37	0.36	0.23	0.18	0.40	0.39	0.24	0.18	0.43	0.41	0.24	0.19
Vertical Horizontal →		32.2	5.6	0.62	0.57	0.21	0.15	0.70	0.64	0.22	0.15	0.65	0.60	0.22	0.15
		10.0	16.7	0.51	0.49	0.23	0.17	0.45	0.43	0.22	0.16	0.47	0.45	0.22	0.16
		10.0	5.6	0.65	0.61	0.25	0.18	0.67	0.62	0.26	0.18	0.64	0.60	0.25	0.18
		-17.8	11.1	0.55	0.53	0.28	0.21	0.49	0.47	0.26	0.20	0.51	0.49	0.27	0.20
45° slope Down ↓		32.2	5.6	0.62	0.58	0.21	0.15	0.89	0.80	0.24	0.16	0.85	0.76	0.24	0.16
		10.0	16.7	0.60	0.57	0.24	0.17	0.63	0.59	0.25	0.18	0.62	0.58	0.25	0.18
		10.0	5.6	0.67	0.63	0.26	0.18	0.90	0.82	0.28	0.19	0.83	0.77	0.28	0.19
		-17.8	11.1	0.66	0.63	0.30	0.22	0.68	0.64	0.31	0.22	0.67	0.64	0.31	0.22
Horizontal Down ↓		32.2	5.6	0.62	0.58	0.21	0.15	1.07	0.94	0.25	0.17	1.77	1.44	0.28	0.18
		10.0	16.7	0.66	0.62	0.25	0.18	1.10	0.99	0.30	0.20	1.69	1.44	0.33	0.21
		10.0	5.6	0.68	0.63	0.26	0.18	1.16	1.04	0.30	0.20	1.96	1.63	0.34	0.22
		-17.8	11.1	0.74	0.70	0.32	0.23	1.24	1.13	0.39	0.26	1.92	1.68	0.43	0.29

(b) English units (in h · ft² · °F/Btu)

Position of Air Space	Direction of Heat Flow	Mean Temp., °F	Temp. Diff., °F	0.75-in Air Space				1.5-in Air Space				3.5-in Air Space			
				Effective Emissivity, ϵ_{eff}				Effective Emissivity, ϵ_{eff}				Effective Emissivity, ϵ_{eff}			
				0.03	0.05	0.5	0.82	0.03	0.05	0.5	0.82	0.03	0.05	0.5	0.82
Horizontal Up ↑		90	10	2.34	2.22	1.04	0.75	2.55	2.41	1.08	0.77	2.84	2.66	1.13	0.80
		50	30	1.71	1.66	0.99	0.77	1.87	1.81	1.04	0.80	2.09	2.01	1.10	0.84
		50	10	2.30	2.21	1.16	0.87	2.50	2.40	1.21	0.89	2.80	2.66	1.28	0.93
		0	20	1.83	1.79	1.16	0.93	2.01	1.95	1.23	0.97	2.25	2.18	1.32	1.03
45° slope Up ↑		90	10	2.96	2.78	1.15	0.81	2.92	2.73	1.14	0.80	3.18	2.96	1.18	0.82
		50	30	1.99	1.92	1.08	0.82	2.14	2.06	1.12	0.84	2.26	2.17	1.15	0.86
		50	10	2.90	2.75	1.29	0.94	2.88	2.74	1.29	0.94	3.12	2.95	1.34	0.96
		0	20	2.13	2.07	1.28	1.00	2.30	2.23	1.34	1.04	2.42	2.35	1.38	1.06
Vertical Horizontal →		90	10	3.50	3.24	1.22	0.84	3.99	3.66	1.27	0.87	3.69	3.40	1.24	0.85
		50	30	2.91	2.77	1.30	0.94	2.58	2.46	1.23	0.90	2.67	2.55	1.25	0.91
		50	10	3.70	3.46	1.43	1.01	3.79	3.55	1.45	1.02	3.63	3.40	1.42	1.01
		0	20	3.14	3.02	1.58	1.18	2.76	2.66	1.48	1.12	2.88	2.78	1.51	1.14
45° slope Down ↓		90	10	3.53	3.27	1.22	0.84	5.07	4.55	1.36	0.91	4.81	4.33	1.34	0.90
		50	30	3.43	3.23	1.39	0.99	3.58	3.36	1.42	1.00	3.51	3.30	1.40	1.00
		50	10	3.81	3.57	1.45	1.02	5.10	4.66	1.60	1.09	4.74	4.36	1.57	1.08
		0	20	3.75	3.57	1.72	1.26	3.85	3.66	1.74	1.27	3.81	3.63	1.74	1.27
Horizontal Down ↓		90	10	3.55	3.29	1.22	0.85	6.09	5.35	1.43	0.94	10.07	8.19	1.57	1.00
		50	30	3.77	3.52	1.44	1.02	6.27	5.63	1.70	1.14	9.60	8.17	1.88	1.22
		50	10	3.84	3.59	1.45	1.02	6.61	5.90	1.73	1.15	11.15	9.27	1.93	1.24
		0	20	4.18	3.96	1.81	1.30	7.03	6.43	2.19	1.49	10.90	9.52	2.47	1.62

table are applicable to air spaces of uniform thickness bounded by plane, smooth, parallel surfaces with no air leakage. Thermal resistances for other temperatures, emissivities, and air spaces can be obtained by interpolation and moderate extrapolation. Note that the presence of a low-emissivity surface reduces radiation heat transfer across an air space and thus significantly increases the thermal resistance. The thermal effectiveness of a low-emissivity surface will decline, however, if the condition of the surface changes as a result of some effects such as condensation, surface oxidation, and dust accumulation.

The R -value of a wall or roof structure that involves layers of uniform thickness is determined easily by simply adding up the unit thermal resistances of the layers that are in series. But when a structure involves components such as wood studs and metal connectors, then the thermal resistance network involves parallel connections and possible two-dimensional effects. The overall R -value in this case can be determined by assuming (1) parallel heat flow paths through areas of different construction or (2) isothermal planes normal to the direction of heat transfer. The first approach usually over-predicts the overall thermal resistance, whereas the second approach usually underpredicts it. The parallel heat flow path approach is more suitable for wood frame walls and roofs, whereas the isothermal planes approach is more suitable for masonry or metal frame walls.

The thermal contact resistance between different components of building structures ranges between 0.01 and $0.1 \text{ m}^2 \cdot \text{C}/\text{W}$, which is negligible in most cases. However, it may be significant for metal building components such as steel framing members.

EXAMPLE 16-6 The R -Value of a Wood Frame Wall

Determine the overall unit thermal resistance (the R -value) and the overall heat transfer coefficient (the U -factor) of a wood frame wall that is built around $38\text{-mm} \times 90\text{-mm}$ (2×4 nominal) wood studs with a center-to-center distance of 400 mm . The 90-mm -wide cavity between the studs is filled with glass fiber insulation. The inside is finished with 13-mm gypsum wallboard and the outside with 13-mm wood fiberboard and $13\text{-mm} \times 200\text{-mm}$ wood bevel lapped siding. The insulated cavity constitutes 75 percent of the heat transmission area while the studs, plates, and sills constitute 21 percent. The headers constitute 4 percent of the area, and they can be treated as studs.

Also, determine the rate of heat loss through the walls of a house whose perimeter is 50 m and wall height is 2.5 m in Las Vegas, Nevada, whose winter design temperature is -2°C . Take the indoor design temperature to be 22°C and assume 20 percent of the wall area is occupied by glazing.

SOLUTION The R -value and the U -factor of a wood frame wall as well as the rate of heat loss through such a wall in Las Vegas are to be determined.

Assumptions 1 Steady operating conditions exist. 2 Heat transfer through the wall is one-dimensional. 3 Thermal properties of the wall and the heat transfer coefficients are constant.

Properties The R -values of different materials are given in Table 16-10.

Analysis The schematic of the wall as well as the different elements used in its construction are shown below. Heat transfer through the insulation and

through the studs will meet different resistances, and thus we need to analyze the thermal resistance for each path separately. Once the unit thermal resistances and the U -factors for the Insulation and stud sections are available, the overall average thermal resistance for the entire wall can be determined from

$$R_{\text{overall}} = 1/U_{\text{overall}}$$

where

$$U_{\text{overall}} = (U \times f_{\text{area}})_{\text{insulation}} + (U \times f_{\text{area}})_{\text{stud}}$$

and the value of the area fraction f_{area} is 0.75 for the insulation section and 0.25 for the stud section since the headers that constitute a small part of the wall are to be treated as studs. Using the available R -values from Table 16-10 and calculating others, the total R -values for each section can be determined in a systematic manner in the table:

Schematic

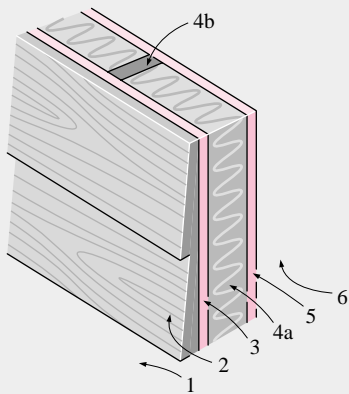

Construction	R-value, m ² · °C/W	
	Between studs	At studs
1. Outside surface, 24 km/h wind	0.030	0.030
2. Wood bevel lapped siding	0.14	0.14
3. Wood fiberboard sheeting, 13 mm	0.23	0.23
4a. Glass fiber insulation, 90 mm	2.45	—
4b. Wood stud, 38 mm × 90 mm	—	0.63
5. Gypsum wallboard, 13 mm	0.079	0.079
6. Inside surface, still air	0.12	0.12

Total unit thermal resistance of each section, R (in m ² · °C/W)	3.05	1.23
The U -factor of each section, $U = 1/R$, in W/m ² · °C	0.328	0.813
Area fraction of each section, f_{area}	0.75	0.25
Overall U -factor: $U = \sum f_{\text{area}, i} U_i = 0.75 \times 0.328 + 0.25 \times 0.813$ $= 0.449 \text{ W/m}^2 \cdot \text{°C}$		
Overall unit thermal resistance: $R = 1/U = 2.23 \text{ m}^2 \cdot \text{°C/W}$		

We conclude that the overall unit thermal resistance of the wall is 2.23 m² · °C/W, and this value accounts for the effects of the studs and headers. It corresponds to an R -value of $2.23 \times 5.68 = 12.7$ (or nearly R -13) in English units. Note that if there were no wood studs and headers in the wall, the overall thermal resistance would be 3.05 m² · °C/W, which is 37 percent greater than 2.23 m² · °C/W. Therefore, the wood studs and headers in this case serve as thermal bridges in wood frame walls, and their effect must be considered in the thermal analysis of buildings.

The perimeter of the building is 50 m and the height of the walls is 2.5 m. Noting that glazing constitutes 20 percent of the walls, the total wall area is

$$A_{\text{wall}} = 0.80(\text{Perimeter})(\text{Height}) = 0.80(50 \text{ m})(2.5 \text{ m}) = 100 \text{ m}^2$$

Then the rate of heat loss through the walls under design conditions becomes

$$\begin{aligned}\dot{Q}_{\text{wall}} &= (UA)_{\text{wall}} (T_i - T_o) \\ &= (0.449 \text{ W/m}^2 \cdot \text{°C})(100 \text{ m}^2)[22 - (-2)\text{°C}] \\ &= \mathbf{1078 \text{ W}}\end{aligned}$$

Discussion Note that a 1-kW resistance heater in this house will make up almost all the heat lost through the walls, except through the doors and windows, when the outdoor air temperature drops to -2°C .

EXAMPLE 16-7 The R -Value of a Wall with Rigid Foam

The 13-mm-thick wood fiberboard sheathing of the wood stud wall discussed in the previous example is replaced by a 25-mm-thick rigid foam insulation. Determine the percent increase in the R -value of the wall as a result.

SOLUTION The overall R -value of the existing wall was determined in Example 16-6 to be $2.23 \text{ m}^2 \cdot \text{°C/W}$. Noting that the R -values of the fiberboard and the foam insulation are $0.23 \text{ m}^2 \cdot \text{°C/W}$ and $0.98 \text{ m}^2 \cdot \text{°C/W}$, respectively, and the added and removed thermal resistances are in series, the overall R -value of the wall after modification becomes

$$\begin{aligned}R_{\text{new}} &= R_{\text{old}} - R_{\text{removed}} + R_{\text{added}} \\ &= 2.23 - 0.23 + 0.98 \\ &= 2.98 \text{ m}^2 \cdot \text{°C/W}\end{aligned}$$

This represents an increase of $(2.98 - 2.23)/2.23 = 0.34$ or **34 percent** in the R -value of the wall. This example demonstrated how to evaluate the new R -value of a structure when some structural members are added or removed.

EXAMPLE 16-8 The R -Value of a Masonry Wall

Determine the overall unit thermal resistance (the R -value) and the overall heat transfer coefficient (the U -factor) of a masonry cavity wall that is built around 150-mm-thick concrete blocks made of lightweight aggregate with 3 cores filled with perlite ($R = 0.74 \text{ m}^2 \cdot \text{°C/W}$). The outside is finished with 100-mm face brick with 13-mm cement mortar between the bricks and concrete blocks. The inside finish consists of 13 mm gypsum wallboard separated from the concrete block by 20-mm-thick (1-in \times 3-in nominal) vertical furring ($R = 0.74 \text{ m}^2 \cdot \text{°C/W}$) whose center-to-center distance is 400 mm. Both sides of the 20-mm-thick air space between the concrete block and the gypsum board are coated with reflective aluminum foil ($\varepsilon = 0.05$) so that the effective emissivity of the air space is 0.03. For a mean temperature of 10°C and a temperature difference of 16.7°C , the R -value of the air space is $0.51 \text{ m}^2 \cdot \text{°C/W}$. The re-

reflective air space constitutes 80 percent of the heat transmission area, while the vertical furring constitutes 20 percent.

SOLUTION The R -value and the U -factor of a masonry cavity wall are to be determined.

Assumptions 1 Steady operating conditions exist. 2 Heat transfer through the wall is one-dimensional. 3 Thermal properties of the wall and the heat transfer coefficients are constant.

Properties The R -values of different materials are given in Table 16-10.

Analysis The schematic of the wall as well as the different elements used in its construction are shown below. Following the approach described above and using the available R -values from Table 16-10, the overall R -value of the wall is determined in the table below.

Schematic

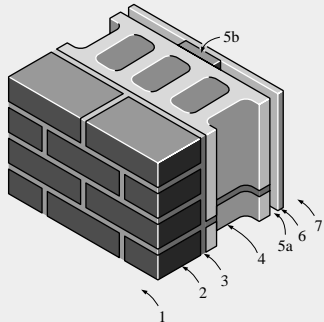

Construction	R -value, $m^2 \cdot ^\circ C/W$	
	Between furring	At furring
1. Outside surface, 24 km/h wind	0.030	0.030
2. Face brick, 100 mm	0.075	0.075
3. Cement mortar, 13 mm	0.018	0.018
4. Concrete block, 150 mm	0.74	0.74
5a. Reflective air space, 20 mm	0.51	—
5b. Nominal 1 × 3 vertical furring	—	0.17
6. Gypsum wallboard, 13 mm	0.079	0.079
7. Inside surface, still air	0.12	0.12

Total unit thermal resistance of each section, R	1.572	1.232
The U -factor of each section, $U = 1/R$, in $W/m^2 \cdot ^\circ C$	0.636	0.812
Area fraction of each section, f_{area}	0.80	0.20
Overall U -factor: $U = \sum f_{area, i} U_i = 0.80 \times 0.636 + 0.20 \times 0.812$ $= 0.671 W/m^2 \cdot ^\circ C$		
Overall unit thermal resistance: $R = 1/U = 1.49 m^2 \cdot ^\circ C/W$		

Therefore, the overall unit thermal resistance of the wall is $1.49 m^2 \cdot ^\circ C/W$ and the overall U -factor is $0.671 W/m^2 \cdot ^\circ C$. These values account for the effects of the vertical furring.

EXAMPLE 16-9 The R -Value of a Pitched Roof

Determine the overall unit thermal resistance (the R -value) and the overall heat transfer coefficient (the U -factor) of a 45° pitched roof built around nominal 2-in × 4-in wood studs with a center-to-center distance of 400 mm. The 90-mm-

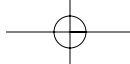

wide air space between the studs does not have any reflective surface and thus its effective emissivity is 0.84. For a mean temperature of 32,2°C and a temperature difference of 16,7°C, the R -value of the air space is 0.15 m² · °C/W. The lower part of the roof is finished with 13-mm gypsum wallboard and the upper part with 16-mm plywood, building paper, and asphalt shingle roofing. The air space constitutes 75 percent of the heat transmission area, while the studs and headers constitute 25 percent.

SOLUTION The R -value and the U -factor of a 45° pitched roof are to be determined.

Assumptions 1 Steady operating conditions exist. 2 Heat transfer through the roof is one-dimensional. 3 Thermal properties of the roof and the heat transfer coefficients are constant.

Properties The R -values of different materials are given in Table 16–10.

Analysis The schematic of the pitched roof as well as the different elements used in its construction are shown below. Following the approach described above and using the available R -values from Table 16–10, the overall R -value of the roof can be determined in the table below.

Schematic

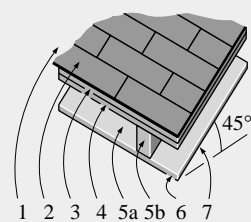

Construction	R-value, m ² · °C/W	
	Between studs	At studs
1. Outside surface, 24 km/h wind	0.030	0.030
2. Asphalt shingle roofing	0.077	0.077
3. Building paper	0.011	0.011
4. Plywood deck, 16 mm	0.14	0.14
5a. Nonreflective air space, 90 mm	0.15	—
5b. Wood stud, 2 in × 4 in	—	0.63
6. Gypsum wallboard, 13 mm	0.079	0.079
7. Inside surface, 45° slope, still air	0.11	0.11

Total unit thermal resistance of each section, R	0.597	1.077
The U -factor of each section, $U = 1/R$, in W/m ² · °C	1.68	0.929
Area fraction of each section, f_{area}	0.75	0.25
Overall U -factor: $U = \sum f_{\text{area}, i} U_i = 0.75 \times 1.68 + 0.25 \times 0.929$ $= 1.49 \text{ W/m}^2 \cdot \text{°C}$		
Overall unit thermal resistance: $R = 1/U = 0.67 \text{ m}^2 \cdot \text{°C/W}$		

Therefore, the overall unit thermal resistance of this pitched roof is 0.67 m² · °C/W and the overall U -factor is 1.49 W/m² · °C. Note that the wood studs offer much larger thermal resistance to heat flow than the air space between the studs.

The construction of wood frame flat ceilings typically involve 2-in × 6-in joists on 400-mm or 600-mm centers. The fraction of framing is usually taken to be 0.10 for joists on 400-mm centers and 0.07 for joists on 600-mm centers.

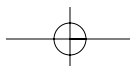

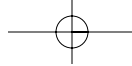

Most buildings have a combination of a ceiling and a roof with an attic space in between, and the determination of the R -value of the roof–attic–ceiling combination depends on whether the attic is vented or not. For adequately ventilated attics, the attic air temperature is practically the same as the outdoor air temperature, and thus heat transfer through the roof is governed by the R -value of the ceiling only. However, heat is also transferred between the roof and the ceiling by radiation, and it needs to be considered (Fig. 16–33). The major function of the roof in this case is to serve as a radiation shield by blocking off solar radiation. Effectively ventilating the attic in summer should not lead one to believe that heat gain to the building through the attic is greatly reduced. This is because most of the heat transfer through the attic is by radiation.

Radiation heat transfer between the ceiling and the roof can be minimized by covering at least one side of the attic (the roof or the ceiling side) by a reflective material, called *radiant barrier*, such as aluminum foil or aluminum-coated paper. Tests on houses with R -19 attic floor insulation have shown that radiant barriers can reduce summer ceiling heat gains by 16 to 42 percent compared to an attic with the same insulation level and no radiant barrier. Considering that the ceiling heat gain represents about 15 to 25 percent of the total cooling load of a house, radiant barriers will reduce the air conditioning costs by 2 to 10 percent. Radiant barriers also reduce the heat loss in winter through the ceiling, but tests have shown that the percentage reduction in heat losses is less. As a result, the percentage reduction in heating costs will be less than the reduction in the air-conditioning costs. Also, the values given are for new and undusted radiant barrier installations, and percentages will be lower for aged or dusty radiant barriers.

Some possible locations for attic radiant barriers are given in Fig. 16–34. In whole house tests on houses with R -19 attic floor insulation, radiant barriers have reduced the ceiling heat gain by an average of 35 percent when the radiant barrier is installed on the attic floor, and by 24 percent when it is attached to the bottom of roof rafters. Test cell tests also demonstrated that the best location for radiant barriers is the attic floor, provided that the attic is not used as a storage area and is kept clean.

For unvented attics, any heat transfer must occur through (1) the ceiling, (2) the attic space, and (3) the roof (Fig. 16–35). Therefore, the overall R -value

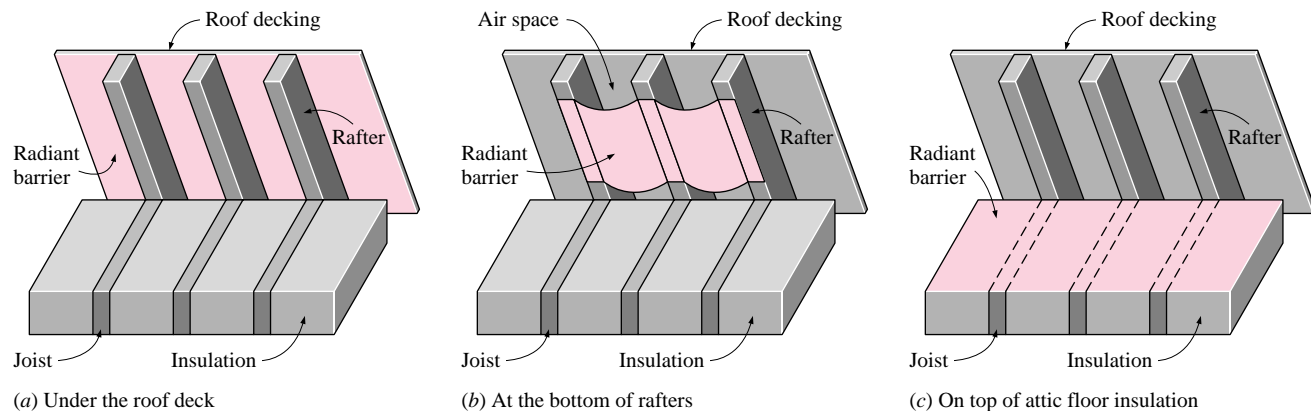

FIGURE 16–34

Three possible locations for an attic radiant barrier.

(From DOE/CE-0335P, U.S. Dept. of Energy.)

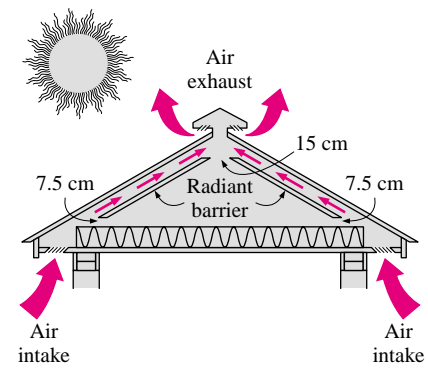
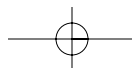

FIGURE 16–33

Ventilation paths for a naturally ventilated attic and the appropriate size of the flow areas around the radiant barrier for proper air circulation.

(From DOE/CE-0335P, U.S. Dept. of Energy.)



16-36
HEATING AND COOLING OF BUILDINGS

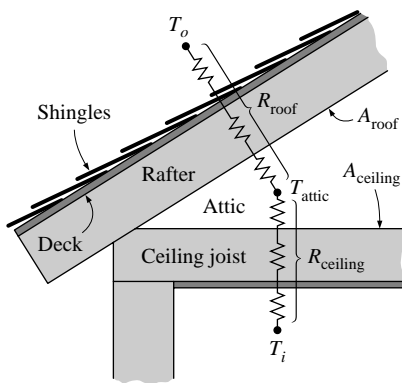

FIGURE 16-35
Thermal resistance network for a pitched roof-attic-ceiling combination for the case of an unvented attic.

of the roof-ceiling combination with an unvented attic depends on the combined effects of the R -value of the ceiling and the R -value of the roof as well as the thermal resistance of the attic space. The attic space can be treated as an air layer in the analysis. But a more practical way of accounting for its effect is to consider surface resistances on the roof and ceiling surfaces facing each other. In this case, the R -values of the ceiling and the roof are first determined separately (by using convection resistances for the still-air case for the attic surfaces). Then it can be shown that the overall R -value of the ceiling-roof combination per unit area of the ceiling can be expressed as

$$R = R_{\text{ceiling}} + R_{\text{roof}} \left(\frac{A_{\text{ceiling}}}{A_{\text{roof}}} \right) \quad (16-25)$$

where A_{ceiling} and A_{roof} are the ceiling and roof areas, respectively. The area ratio is equal to 1 for flat roofs and is less than 1 for pitched roofs. For a 45° pitched roof, the area ratio is $A_{\text{ceiling}}/A_{\text{roof}} = 1/\sqrt{2} = 0.707$. Note that the pitched roof has a greater area for heat transfer than the flat ceiling, and the area ratio accounts for the reduction in the unit R -value of the roof when expressed per unit area of the ceiling. Also, the direction of heat flow is up in winter (heat loss through the roof) and down in summer (heat gain through the roof).

The R -value of a structure determined by analysis assumes that the materials used and the quality of workmanship meet the standards. Poor workmanship and substandard materials used during construction may result in R -values that deviate from predicted values. Therefore, some engineers use a safety factor in their designs based on experience in critical applications.

16-7 ■ HEAT LOSS FROM BASEMENT WALLS AND FLOORS

The floors and the underground portion of the walls of a basement are in direct contact with the ground, which is usually at a different temperature than the basement, and thus there is heat transfer between the basement and the ground. This is *conduction heat transfer* because of the direct contact between the walls and the floor, and it depends on the temperature difference between the basement and the ground, the construction of the walls and the floor, and the thermal conductivity of the surrounding earth. There is considerable uncertainty in the ground heat loss calculations, and they probably constitute the least accurate part of heat load estimates of a building because of the large thermal mass of the ground and the large variation of the thermal conductivity of the soil [it varies between 0.5 and $2.5 \text{ W/m} \cdot ^\circ\text{C}$, depending on the composition and moisture content]. However, ground heat losses are a small fraction of total heat load of a large building, and thus it has little effect on the overall heat load.

Temperature measurements of uninsulated basements indicate that heat conduction through the ground is not one-dimensional, and thus it cannot be estimated by a simple one-dimensional heat conduction analysis. Instead, heat conduction is observed to be two-dimensional with nearly circular concentric heat flow lines centered at the intersection of the wall and the earth (Fig. 16-36). When partial insulation is applied to the walls, the heat flow lines

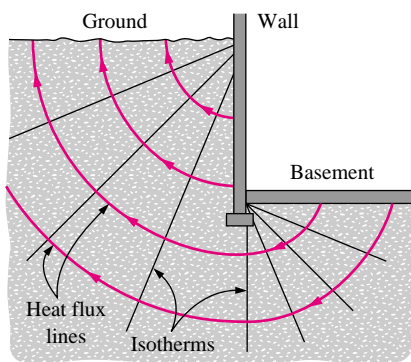

FIGURE 16-36
Radial isotherms and circular heat flow lines during heat flow from uninsulated basement.

tend to be straight lines rather than being circular. Also, a basement wall whose top portion is exposed to ambient air may act as a thermal bridge, conducting heat upward and dissipating it to the ambient from its top part. This vertical heat flow may be significant in some cases.

Despite its complexity, heat loss through the below-grade section of **basement walls** can be determined easily from

$$\dot{Q}_{\text{basement walls}} = U_{\text{wall, avg}} A_{\text{wall}} (T_{\text{basement}} - T_{\text{ground surface}}) \quad (\text{W}) \quad (16-26)$$

where

$U_{\text{wall, avg}}$ = Average overall heat transfer coefficient between the basement wall and the surface of the ground

$A_{\text{wall, avg}}$ = Wall surface area of the basement (underground portion)

T_{basement} = Interior air temperature of the basement

$T_{\text{ground surface}}$ = Mean ground surface temperature in winter

The overall heat transfer coefficients at different depths are given in Table 16-14a for depth increments of 0.3 m for uninsulated and insulated concrete walls. These values are based on a soil thermal conductivity of 1.38 W/m · °C. Note that the heat transfer coefficient values decrease with increasing depth since the heat at a lower section must pass through a longer path to reach the ground surface. For a specified wall, $U_{\text{wall, avg}}$ is simply the arithmetic average of the U_{wall} values corresponding to the different sections of the wall. Also note that heat loss through a depth increment is equal to the U_{wall} value of the increment multiplied by the perimeter of the building, the depth increment, and the temperature difference.

The interior air temperature of the basement can vary considerably, depending on whether it is being heated or not. In the absence of reliable data, the basement temperature can be taken to be 10°C since the heating system, water heater, and heating ducts are often located in the basement. Also, the ground surface temperature fluctuates about the mean winter ambient temperature by an amplitude A that varies with geographic location and the condition of the surface, as shown in Fig. 16-37. Therefore, a reasonable value for the design temperature of ground surface can be obtained by subtracting A for the specified location from the mean winter air temperature. That is,

$$T_{\text{ground surface}} = T_{\text{winter, mean}} - A \quad (16-27)$$

Heat loss through the **basement floor** is much smaller since the heat flow path to the ground surface is much longer in this case. It is calculated in a similar manner from

$$\dot{Q}_{\text{basement floor}} = U_{\text{floor}} A_{\text{floor}} (T_{\text{basement}} - T_{\text{ground surface}}) \quad (\text{W}) \quad (16-28)$$

where U_{floor} is the overall heat transfer coefficient at the basement floor whose values are listed in Table 16-14b, A_{floor} is the floor area, and the temperature difference is the same as the one used for the basement wall.

The temperature of an unheated below-grade basement is between the temperatures of the rooms above and the ground temperature. Heat losses from the water heater and the space heater located in the basement usually keep the air near the basement ceiling sufficiently warm. Heat losses from the rooms above to the basement can be neglected in such cases. This will not be the case, however, if the basement has windows.

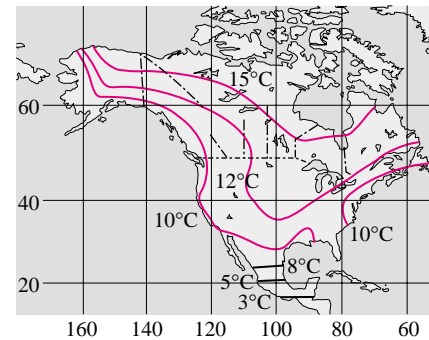

FIGURE 16-37
Lines of constant amplitude of annual soil temperature swings.
(From ASHRAE Handbook of Fundamentals, Chap. 25, Fig. 6).

TABLE 16-14

Heat transfer coefficients for heat loss through the basement walls, basement floors, and concrete floors on grade in both SI and English units (from ASHRAE *Handbook of Fundamentals*, Chap. 25, Tables 14,15,16)

(a) Heat loss through below-grade basement walls

<i>SI Units</i>					<i>English Units</i>				
$U_{\text{wall}}, \text{W/m}^2 \cdot ^\circ\text{C}$					$U_{\text{wall}}, \text{Btu/h} \cdot \text{ft}^2 \cdot ^\circ\text{F}$				
Insulation level, $\text{m}^2 \cdot ^\circ\text{C/W}$					Insulation level, $\text{h} \cdot \text{ft}^2 \cdot ^\circ\text{F/Btu}$				
Depth, m	No insulation	R-0.73	R-1.47	R-2.2	Depth, ft	No insulation	R-4.17	R-8.34	R-12.5
0.0–0.3	7.77	2.87	1.77	1.27	0–0	0.410	0.152	0.093	0.067
0.3–0.6	4.20	2.20	1.50	1.20	1–2	0.222	0.116	0.079	0.059
0.6–0.9	2.93	1.77	1.27	1.00	2–3	0.155	0.094	0.068	0.053
0.9–1.2	2.23	1.50	1.13	0.90	3–4	0.119	0.079	0.060	0.048
1.2–1.5	1.80	1.30	1.00	0.83	4–5	0.096	0.069	0.053	0.044
1.5–1.8	1.50	1.13	0.90	0.77	5–6	0.079	0.060	0.048	0.040
1.8–2.1	1.30	1.00	0.83	0.70	6–7	0.069	0.054	0.044	0.037

(b) Heat loss through below-grade basement floors

$U_{\text{floor}}, \text{W/m}^2 \cdot ^\circ\text{C}$					$U_{\text{floor}}, \text{Btu/h} \cdot \text{ft}^2 \cdot ^\circ\text{F}$				
Shortest width of building, m					Shortest width of building, ft				
Depth of wall below grade, m	6.0	7.3	8.5	9.7	Depth of wall below grade, ft	20	24	28	32
1.5	0.18	0.16	0.15	0.13	5	0.032	0.029	0.026	0.023
1.8	0.17	0.15	0.14	0.12	6	0.030	0.027	0.025	0.022
2.1	0.16	0.15	0.13	0.12	7	0.029	0.026	0.023	0.021

(c) Heat loss through on-grade concrete basement floors

$U_{\text{grade}}, \text{W/m} \cdot ^\circ\text{C}$ (per unit length of perimeter)					$U_{\text{grade}}, \text{Btu/h} \cdot \text{ft} \cdot ^\circ\text{F}$ (per unit length of perimeter)				
Wall construction	Insulation (from edge to footer)	Weather conditions			Wall construction	Insulation (from edge to footer)	Weather conditions		
		Mild	Moderate	Severe			Mild	Moderate	Severe
8-in (20-cm) block wall with brick	None	1.24	1.17	1.07	8-in (20-cm) block wall with brick	None	0.62	0.68	0.72
	R-0.95	0.97	0.86	0.83		R-5.4	0.48	0.50	0.56
4-in (10-cm) block wall with brick	None	1.61	1.45	1.38	4-in (10-cm) block wall with brick	None	0.80	0.84	0.93
	R-0.95	0.93	0.85	0.81		R-5.4	0.47	0.49	0.54
Metal-stud wall with stucco	None	2.32	2.07	1.99	Metal-stud wall with stucco	None	1.15	1.20	1.34
	R-0.95	1.00	0.92	0.88		R-5.4	0.51	0.53	0.38
Poured concrete wall with heating pipes or ducts near perimeter	None	4.72	3.67	3.18	Poured concrete wall with heating pipes or ducts near perimeter	None	1.84	2.12	2.73
	R-0.95	1.56	1.24	1.11		R-5.4	0.64	0.72	0.90

EXAMPLE 16-10 Heat Loss from a Below-Grade Basement

Consider a basement in Chicago, where the mean winter temperature is 2.4°C . The basement is 8.5 m wide and 12 m long, and the basement floor is 2.1 m below grade (the ground level). The top 0.9-m section of the wall below the grade is insulated with $R\text{-}2.20\text{ m}^2 \cdot ^{\circ}\text{C}/\text{W}$ insulation. Assuming the interior temperature of the basement is 22°C , determine the peak heat loss from the basement to the ground through its walls and floor.

SOLUTION The peak heat loss from a below-grade basement in Chicago to the ground through its walls and the floor is to be determined.

Assumption Steady operating conditions exist.

Properties The heat transfer coefficients are given in Table 16-14.

Analysis The schematic of the basement is given in Fig. 16-38. The floor and wall areas of the basement are

$$A_{\text{wall}} = \text{Height} \times \text{Perimeter} = 2 \times (2.1\text{ m})(8.5 + 12)\text{ m} = 86.1\text{ m}^2$$

$$A_{\text{floor}} = \text{Length} \times \text{Width} = (8.5\text{ m})(12\text{ m}) = 102\text{ m}^2$$

The amplitude of the annual soil temperature is determined from Fig. 16-37 to be 12°C . Then the ground surface temperature for the design heat loss becomes

$$T_{\text{ground surface}} = T_{\text{winter, mean}} - A = 2.4 - 12 = -9.6^{\circ}\text{C}$$

The top 0.9-m section of the wall below the grade is insulated with $R\text{-}2.2$, and the heat transfer coefficients through that section are given in Table 16-14a to be 1.27 , 1.20 , and $1.00\text{ W/m}^2 \cdot ^{\circ}\text{C}$ through the first, second, and third 0.3-m -wide depth increments, respectively. The heat transfer coefficients through the uninsulated section of the wall that extends from the 0.9-m to the 2.1-m level are determined from the same table to be 2.23 , 1.80 , 1.50 , and $1.30\text{ W/m}^2 \cdot ^{\circ}\text{C}$ for each of the remaining 0.3-m -wide depth increments. The average overall heat transfer coefficient is

$$U_{\text{wall, avg}} = \frac{\sum U_{\text{wall}}}{\text{No. of increments}} = \frac{1.27 + 1.2 + 1.0 + 2.23 + 1.8 + 1.5 + 1.3}{7} = 1.47\text{ W/m}^2 \cdot ^{\circ}\text{C}$$

Then the heat loss through the basement wall becomes

$$\begin{aligned} \dot{Q}_{\text{basement walls}} &= U_{\text{wall, avg}} A_{\text{wall}} (T_{\text{basement}} - T_{\text{ground surface}}) \\ &= (1.47\text{ W/m}^2 \cdot ^{\circ}\text{C})(86.1\text{ m}^2)[22 - (-9.6)^{\circ}\text{C}] = 4000\text{ W} \end{aligned}$$

The shortest width of the house is 8.5 m , and the depth of the foundation below grade is 2.1 m . The floor heat transfer coefficient is given in Table 16-14b to be $0.13\text{ W/m}^2 \cdot ^{\circ}\text{C}$. Then the heat loss through the floor of the basement becomes

$$\begin{aligned} \dot{Q}_{\text{basement floor}} &= U_{\text{floor}} A_{\text{floor}} (T_{\text{basement}} - T_{\text{ground surface}}) \\ &= (0.13\text{ W/m}^2 \cdot ^{\circ}\text{C})(102\text{ m}^2)[22 - (-9.6)^{\circ}\text{C}] = 419\text{ W} \end{aligned}$$

which is considerably less than the heat loss through the wall. The total heat loss from the basement is then determined to be

$$\dot{Q}_{\text{basement}} = \dot{Q}_{\text{basement walls}} + \dot{Q}_{\text{basement floor}} = 4000 + 419 = \mathbf{4419\text{ W}}$$

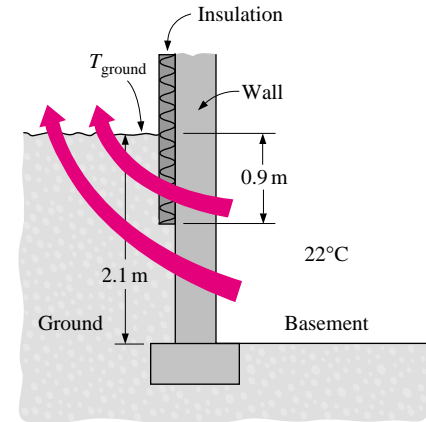

FIGURE 16-38
Schematic for Example 16-10.

This is the *design* or *peak* rate of heat transfer from the below-grade section of the basement, and this is the value to be used when sizing the heating system. The actual heat loss from the basement will be much less than that most of the time.

Concrete Floors on Grade (at Ground Level)

Many residential and commercial buildings do not have a basement, and the floor sits directly on the ground at or slightly above the ground level. Research indicates that heat loss from such floors is mostly through the perimeter to the outside air rather than through the floor into the ground, as shown in Fig. 16–39. Therefore, total heat loss from a concrete slab floor is proportional to the perimeter of the slab instead of the area of the floor and is expressed as

$$\dot{Q}_{\text{floor on grade}} = U_{\text{grade}} p_{\text{floor}} (T_{\text{indoor}} - T_{\text{outdoor}}) \quad (\text{W}) \quad (16-29)$$

where U_{grade} represents the rate of heat transfer from the slab per unit temperature difference between the indoor temperature T_{indoor} and the outdoor temperature T_{outdoor} and per unit length of the perimeter p_{floor} of the building.

Typical values of U_{grade} are listed in Table 16–14c for four common types of slab-on-grade construction for mild, moderate, and severe weather conditions. The ground temperature is not involved in the formulation since the slab is located above the ground level and heat loss to the ground is negligible. Note from the table that perimeter insulation of slab-on-grade reduces heat losses considerably, and thus it saves energy while enhancing comfort. Insulation is a must for radiating floors that contain heated pipes or ducts through which hot water or air is circulated since heat loss in the uninsulated case is about three times that of the insulated case. This is also the case when base board heaters are used on the floor near the exterior walls. Heat transfer through the floors and the basement is usually ignored in cooling load calculations.

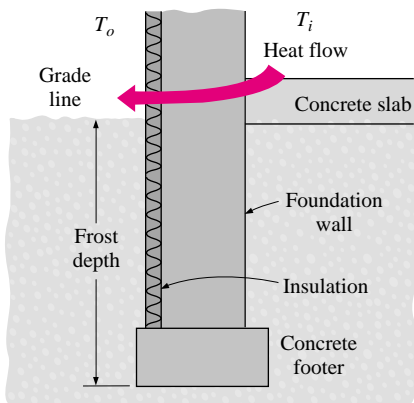

FIGURE 16–39
An on-grade concrete floor with insulated foundation wall.

Heat Loss from Crawl Spaces

A crawl space can be considered to be a small basement except that it may be vented year round to prevent the accumulation of moisture and radioactive gases such as radon. Venting the crawl space during the heating season creates a low temperature region underneath the house and causes considerable heat loss through the floor. The ceiling of the crawl space (i.e., the floor of the building) in such cases must be insulated. If the vents are closed during the heating season, then the walls of the crawl space can be insulated instead.

The temperature of the crawl space will be very close to the ambient air temperature when it is well ventilated. The heating ducts and hot water pipes passing through the crawl space must be adequately insulated in this case. In severe climates, it may even be necessary to insulate the cold water pipes to prevent freezing. The temperature of the crawl space will approach the indoor temperature when the vents are closed for the heating season. The air infiltration in this case is estimated to be 0.67 air change per hour.

When the crawl space temperature is known, heat loss through the **floor of the building** is determined from

$$\dot{Q}_{\text{building floor}} = U_{\text{building floor}} A_{\text{floor}} (T_{\text{indoor}} - T_{\text{crawl}}) \quad (\text{W}) \quad (16-30)$$

where $U_{\text{building floor}}$ is the overall heat transfer coefficient for the floor, A_{floor} is the floor area, and T_{indoor} and T_{crawl} are the indoor and crawl space temperatures, respectively.

Overall heat transfer coefficients associated with the walls, floors, and ceilings of typical crawl spaces are given in Table 16–15. Note that heat loss through the uninsulated floor to the crawl space is three times that of the insulated floor. The ground temperature can be taken to be 10°C when calculating heat loss from the crawl space to the ground. Also, the infiltration heat loss from the crawl space can be determined from

$$\begin{aligned} \dot{Q}_{\text{infiltration, crawl}} &= (\rho c_p \dot{V})_{\text{air}} (T_{\text{crawl}} - T_{\text{ambient}}) \\ &= \rho c_p (\text{ACH})(V_{\text{crawl}})(T_{\text{crawl}} - T_{\text{ambient}}) \quad (\text{J/h}) \quad (16-31) \end{aligned}$$

where ACH is the air changes per hour, V_{crawl} is the volume of the crawl space, and T_{crawl} and T_{ambient} are the crawl space and ambient temperatures, respectively.

In the case of *closed vents*, the steady state temperature of the crawl space will be between the indoors and outdoors temperatures and can be determined from the energy balance expressed as

$$\dot{Q}_{\text{floor}} + \dot{Q}_{\text{infiltration}} + \dot{Q}_{\text{ground}} + \dot{Q}_{\text{wall}} = 0 \quad (\text{W}) \quad (16-32)$$

and assuming all heat transfer to be toward the crawl space for convenience in formulation.

EXAMPLE 16-11 Heat Loss to the Crawl Space through Floors

Consider a crawl space that is 8-m wide, 21-m long, and 0.70-m high, as shown in Fig. 16–40, whose vent is kept open. The interior of the house is maintained at 22°C and the ambient temperature is –5°C. Determine the rate of heat loss through the floor of the house to the crawl space for the cases of (a) an insulated and (b) an uninsulated floor.

SOLUTION The vent of the crawl space is kept open. The rate of heat loss to the crawl space through insulated and uninsulated floors is to be determined.

Assumption Steady operating conditions exist.

Properties The overall heat transfer coefficient for the insulated floor is given in Table 16–15 to be 0.432 W/m² · °C.

Analysis (a) The floor area of the house (or the ceiling area of the crawl space) is

$$A_{\text{floor}} = \text{Length} \times \text{Width} = (8 \text{ m})(12 \text{ m}) = 96 \text{ m}^2$$

Then the heat loss from the house to the crawl space becomes

$$\begin{aligned} \dot{Q}_{\text{insulated floor}} &= U_{\text{insulated floor}} A_{\text{floor}} (T_{\text{indoor}} - T_{\text{crawl}}) \\ &= (0.432 \text{ W/m}^2 \cdot \text{°C})(96 \text{ m}^2)[(22 - (-5))\text{°C}] = \mathbf{1120 \text{ W}} \end{aligned}$$

(b) The heat loss for the uninsulated case is determined similarly to be

$$\begin{aligned} \dot{Q}_{\text{uninsulated floor}} &= U_{\text{uninsulated floor}} A_{\text{floor}} (T_{\text{indoor}} - T_{\text{crawl}}) \\ &= (1.42 \text{ W/m}^2 \cdot \text{°C})(96 \text{ m}^2)[(22 - (-5))\text{°C}] = \mathbf{3681 \text{ W}} \end{aligned}$$

TABLE 16–15

Estimated U -values for insulated and uninsulated crawl spaces (from *ASHRAE Handbook of Fundamentals*, Chap. 25, Table 13)

Application	$U, \text{W/m}^2 \cdot \text{°C}$	
	Un-insulated	In-sulated*
Floor above crawl space	1.42	0.432
Ground of crawl, space	0.437	0.437
Wall of crawl space	2.77	1.07

*An insulation R -value of 1.94 m² · °C/W is used on the floor, and 0.95 m² · °C/W on the walls.

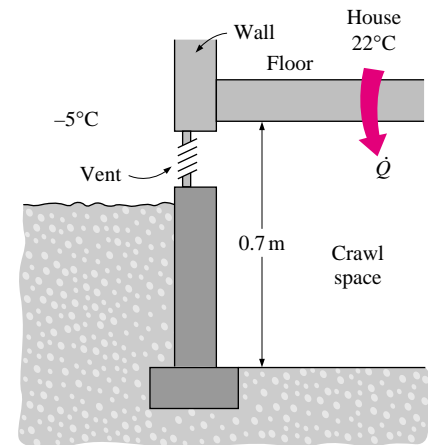

FIGURE 16–40 Schematic for Example 16–11.

which is more than three times the heat loss through the insulated floor. Therefore, it is a good practice to insulate floors when the crawl space is ventilated to conserve energy and enhance comfort

16-8 ■ HEAT TRANSFER THROUGH WINDOWS

Windows are *glazed apertures* in the building envelope that typically consist of single or multiple glazing (glass or plastic), framing, and shading. In a building envelope, windows offer the least resistance to heat transfer. In a typical-house, about one-third of the total heat loss in winter occurs through the windows. Also, most air infiltration occurs at the edges of the windows. The solar heat gain through the windows is responsible for much of the cooling load in summer. The net effect of a window on the heat balance of a building depends on the characteristics and orientation of the window as well as the solar and weather data. Workmanship is very important in the construction and installation of windows to provide effective sealing around the edges while allowing them to be opened and closed easily.

Despite being so undesirable from an energy conservation point of view, windows are an essential part of any building envelope since they enhance the appearance of the building, allow daylight and solar heat to come in, and allow people to view and observe outside without leaving their home. For low-rise buildings, windows also provide easy exit areas during emergencies such as fire. Important considerations in the selection of windows are *thermal comfort* and *energy conservation*. A window should have a good light transmittance while providing effective resistance to heat transfer. The lighting requirements of a building can be minimized by maximizing the use of natural daylight. Heat loss in winter through the windows can be minimized by using airtight double- or triple-pane windows with spectrally selective films or coatings, and letting in as much solar radiation as possible. Heat gain and thus cooling load in summer can be minimized by using effective internal or external shading on the windows.

Even in the absence of solar radiation and air infiltration, heat transfer through the windows is more complicated than it appears to be. This is because the structure and properties of the frame are quite different than the glazing. As a result, heat transfer through the frame and the edge section of the glazing adjacent to the frame is two-dimensional. Therefore, it is customary to consider the window in three regions when analyzing heat transfer through it: (1) the *center-of-glass*, (2) the *edge-of-glass*, and (3) the *frame* regions, as shown in Fig. 16-41. Then the total rate of heat transfer through the window is determined by adding the heat transfer through each region as

$$\begin{aligned}\dot{Q}_{\text{window}} &= \dot{Q}_{\text{center}} + \dot{Q}_{\text{edge}} + \dot{Q}_{\text{frame}} \\ &= U_{\text{window}} A_{\text{window}} (T_{\text{indoors}} - T_{\text{outdoors}})\end{aligned}\quad (16-33)$$

where

$$U_{\text{window}} = (U_{\text{center}} A_{\text{center}} + U_{\text{edge}} A_{\text{edge}} + U_{\text{frame}} A_{\text{frame}}) / A_{\text{window}} \quad (16-34)$$

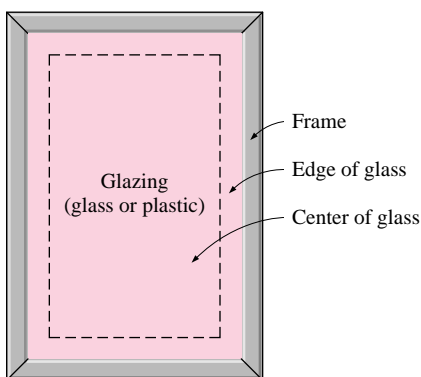

FIGURE 16-41

The three regions of a window considered in heat transfer analysis.

is the ***U*-factor** or the **overall heat transfer coefficient** of the window; A_{window} is the window area; A_{center} , A_{edge} , and A_{frame} are the areas of the center, edge, and frame sections of the window, respectively; and U_{center} , U_{edge} , and U_{frame} are the heat transfer coefficients for the center, edge, and frame sections of the window. Note that $A_{\text{window}} = A_{\text{center}} + A_{\text{edge}} + A_{\text{frame}}$, and the overall *U*-factor of the window is determined from the area-weighted *U*-factors of each region of the window. Also, the inverse of the *U*-factor is the *R*-value, which is the unit thermal resistance of the window (thermal resistance for a unit area).

Consider steady one-dimensional heat transfer through a single-pane glass of thickness L and thermal conductivity k . The thermal resistance network of this problem consists of surface resistances on the inner and outer surfaces and the conduction resistance of the glass in series, as shown in Fig. 16-42, and the total resistance on a unit area basis can be expressed as

$$R_{\text{total}} = R_{\text{inside}} + R_{\text{glass}} + R_{\text{outside}} = \frac{1}{h_i} + \frac{L_{\text{glass}}}{k_{\text{glass}}} + \frac{1}{h_o} \quad (16-35)$$

Using common values of 3 mm for the thickness and $0.92 \text{ W/m} \cdot ^\circ\text{C}$ for the thermal conductivity of the glass and the winter design values of 8.29 and $34.0 \text{ W/m}^2 \cdot ^\circ\text{C}$ for the inner and outer surface heat transfer coefficients, the thermal resistance of the glass is determined to be

$$\begin{aligned} R_{\text{total}} &= \frac{1}{8.29 \text{ W/m}^2 \cdot ^\circ\text{C}} + \frac{0.003 \text{ m}}{0.92 \text{ W/m} \cdot ^\circ\text{C}} + \frac{1}{34.0 \text{ W/m}^2 \cdot ^\circ\text{C}} \\ &= 0.121 + 0.003 + 0.029 = 0.153 \text{ m}^2 \cdot ^\circ\text{C/W} \end{aligned}$$

Note that the ratio of the glass resistance to the total resistance is

$$\frac{R_{\text{glass}}}{R_{\text{total}}} = \frac{0.003 \text{ m}^2 \cdot ^\circ\text{C/W}}{0.153 \text{ m}^2 \cdot ^\circ\text{C/W}} = 2.0\%$$

That is, the glass layer itself contributes about 2 percent of the total thermal resistance of the window, which is negligible. The situation would not be much different if we used acrylic, whose thermal conductivity is $0.19 \text{ W/m} \cdot ^\circ\text{C}$, instead of glass. Therefore, we cannot reduce the heat transfer through the window effectively by simply increasing the thickness of the glass. But we can reduce it by trapping still air between two layers of glass. The result is a **double-pane window**, which has become the norm in window construction.

The thermal conductivity of air at room temperature is $k_{\text{air}} = 0.025 \text{ W/m} \cdot ^\circ\text{C}$, which is one-thirtieth that of glass. Therefore, the thermal resistance of 1-cm-thick still air is equivalent to the thermal resistance of a 30-cm-thick glass layer. Disregarding the thermal resistances of glass layers, the thermal resistance and *U*-factor of a double-pane window can be expressed as (Fig. 16-43)

$$\frac{1}{U_{\text{double-pane (center region)}}} \cong \frac{1}{h_i} + \frac{1}{h_{\text{space}}} + \frac{1}{h_o} \quad (16-36)$$

where $h_{\text{space}} = h_{\text{rad, space}} + h_{\text{conv, space}}$ is the combined radiation and convection heat transfer coefficient of the space trapped between the two glass layers.

Roughly half of the heat transfer through the air space of a double-pane window is by radiation and the other half is by conduction (or convection, if

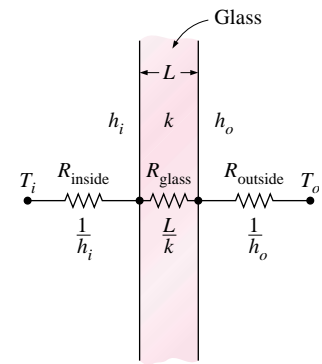

FIGURE 16-42

The thermal resistance network for heat transfer through a single glass.

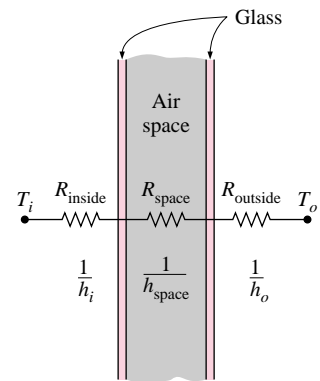

FIGURE 16-43

The thermal resistance network for heat transfer through the center section of a double-pane window (the resistances of the glasses are neglected).



there is any air motion). Therefore, there are two ways to minimize h_{space} and thus the rate of heat transfer through a double-pane window:

1. *Minimize radiation heat transfer through the air space.* This can be done by reducing the emissivity of glass surfaces by coating them with low-emissivity (or “low-e” for short) material. Recall that the *effective emissivity* of two parallel plates of emissivities ϵ_1 and ϵ_2 is given by

$$\epsilon_{\text{effective}} = \frac{1}{1/\epsilon_1 + 1/\epsilon_2 - 1}$$

The emissivity of an ordinary glass surface is 0.84. Therefore, the effective emissivity of two parallel glass surfaces facing each other is 0.72. But when the glass surfaces are coated with a film that has an emissivity of 0.1, the effective emissivity reduces to 0.05, which is one-fourteenth of 0.72. Then for the same surface temperatures, radiation heat transfer will also go down by a factor of 14. Even if only one of the surfaces is coated, the overall emissivity reduces to 0.1, which is the emissivity of the coating. Thus it is no surprise that about one-fourth of all windows sold for residences have a low-e coating. The heat transfer coefficient h_{space} for the air space trapped between the two vertical parallel glass layers is given in Table 16–16 for 13-mm- and 6-mm-thick air spaces for various effective emissivities and temperature differences.

It can be shown that coating just one of the two parallel surfaces facing each other by a material of emissivity ϵ reduces the effective emissivity nearly to ϵ . Therefore, it is usually more economical to coat only one of the facing surfaces. Note from Fig. 16–44 that coating one of the interior surfaces of a double-pane window with a material having an emissivity of 0.1 reduces the rate of heat transfer through the center section of the window by half.

TABLE 16–16

The heat transfer coefficient h_{space} for the air space trapped between the two vertical parallel glass layers for 13-mm- and 6-mm-thick air spaces (from *Building Materials and Structures, Report 151, U.S. Dept. of Commerce*).

(a) Air space thickness = 13 mm

(b) Air space thickness = 6 mm

		$h_{\text{space}}, \text{W/m}^2 \cdot ^\circ\text{C}$						$h_{\text{space}}, \text{W/m}^2 \cdot ^\circ\text{C}$			
		$\epsilon_{\text{effective}}$						$\epsilon_{\text{effective}}$			
$T_{\text{avg}},$ $^\circ\text{C}$	$\Delta T,$ $^\circ\text{C}$	0.72	0.4	0.2	0.1	$T_{\text{avg}},$ $^\circ\text{C}$	$\Delta T,$ $^\circ\text{C}$	0.72	0.4	0.2	0.1
0	5	5.3	3.8	2.9	2.4	0	5	7.2	5.7	4.8	4.3
0	15	5.3	3.8	2.9	2.4	0	50	7.2	5.7	4.8	4.3
0	30	5.5	4.0	3.1	2.6	10	5	7.7	6.0	5.0	4.5
10	5	5.7	4.1	3.0	2.5	10	50	7.7	6.1	5.0	4.5
10	15	5.7	4.1	3.1	2.5	30	5	8.8	6.8	5.5	4.9
10	30	6.0	4.3	3.3	2.7	30	50	8.8	6.8	5.5	4.9
30	5	5.7	4.6	3.4	2.7	50	5	10.0	7.5	6.0	5.2
30	15	5.7	4.7	3.4	2.8	50	50	10.0	7.5	6.0	5.2
30	30	6.0	4.9	3.6	3.0						

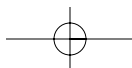

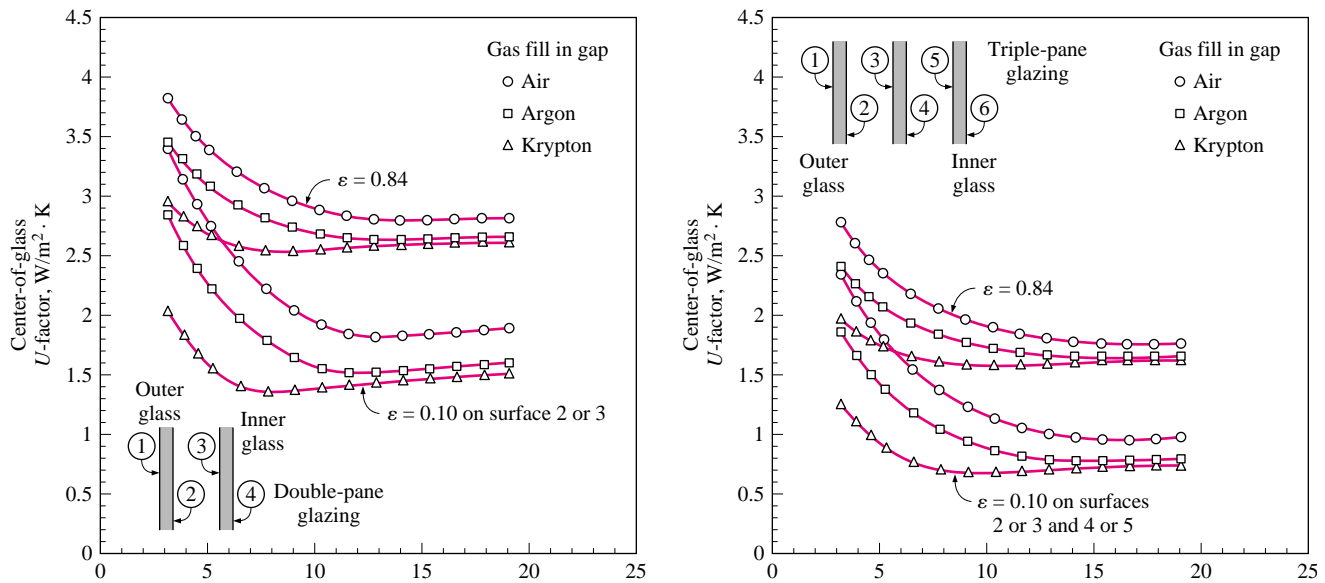

FIGURE 16-44

The variation of the U -factor for the center section of double- and triple-pane windows with uniform spacing between the panes.

(From ASHRAE Handbook of Fundamentals, Chap. 27, Fig. 1.)

2. *Minimize conduction heat transfer through air space.* This can be done by increasing the distance d between the two glasses. However, this cannot be done indefinitely since increasing the spacing beyond a critical value initiates convection currents in the enclosed air space, which increases the heat transfer coefficient and thus defeats the purpose. Besides, increasing the spacing also increases the thickness of the necessary framing and the cost of the window.

Experimental studies have shown that when the spacing d is less than about 13 mm, there is no convection, and heat transfer through the air is by conduction. But as the spacing is increased further, convection currents appear in the air space, and the increase in heat transfer coefficient offsets any benefit obtained by the thicker air layer. As a result, the heat transfer coefficient remains nearly constant, as shown in Fig. 16-44. Therefore, it makes no sense to use an air space thicker than 13 mm in a double-pane window unless a thin polyester film is used to divide the air space into two halves to suppress convection currents. The film provides added insulation without adding much to the weight or cost of the double-pane window. The thermal resistance of the window can be increased further by using triple- or quadruple-pane windows whenever it is economical to do so. Note that using a triple-pane window instead of a double-pane reduces the rate of heat transfer through the center section of the window by about one-third.

Another way of reducing conduction heat transfer through a double-pane window is to use a *less-conducting fluid* such as argon or krypton to fill the gap between the glasses instead of air. The gap in this case needs to be well sealed to prevent the gas from leaking outside. Of course, another alternative is to evacuate the gap between the glasses completely, but it is not practical to do so.

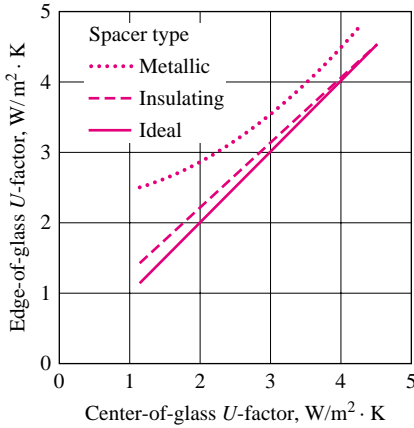
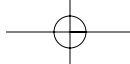

FIGURE 16-45
The edge-of-glass U -factor relative to the center-of glass U - for windows with various spacers.

(From ASHRAE Handbook of fundamentals, Chap. 27, Fig. 2.)

Edge-of-Glass U -Factor of a Window

The glasses in double- and triple-pane windows are kept apart from each other at a uniform distance by **spacers** made of metals or insulators like aluminum, fiberglass, wood, and butyl. Continuous spacer strips are placed around the glass perimeter to provide edge seal as well as uniform spacing. However, the spacers also serve as undesirable “thermal bridges” between the glasses, which are at different temperatures, and this short-circuiting may increase heat transfer through the window considerably. Heat transfer in the edge region of a window is two-dimensional, and lab measurements indicate that the edge effects are limited to a 6.5-cm-wide band around the perimeter of the glass.

The U -factor for the edge region of a window is given in Fig. 16-45 relative to the U -factor for the center region of the window. The curve would be a straight diagonal line if the two U -values were equal to each other. Note that this is almost the case for insulating spacers such as wood and fiberglass. But the U -factor for the edge region can be twice that of the center region for conducting spacers such as those made of aluminum. Values for steel spacers fall between the two curves for metallic and insulating spacers. The edge effect is not applicable to single-pane windows.

Frame U -Factor

The framing of a window consists of the entire window except the glazing. Heat transfer through the framing is difficult to determine because of the different window configurations, different sizes, different constructions, and different combination of materials used in the frame construction. The type of glazing such as single pane, double pane, and triple pane affects the thickness of the framing and thus heat transfer through the frame. Most frames are made of *wood, aluminum, vinyl, or fiberglass*. However, using a combination of these materials (such as aluminum-clad wood and vinyl-clad aluminum) is also common to improve appearance and durability.

Aluminum is a popular framing material because it is inexpensive, durable, and easy to manufacture, and does not rot or absorb water like wood. However, from a heat transfer point of view, it is the least desirable framing material because of its high thermal conductivity. It will come as no surprise that the U -factor of solid aluminum frames is the highest, and thus a window with aluminum framing will lose much more heat than a comparable window with wood or vinyl framing. Heat transfer through the aluminum framing members can be reduced by using plastic inserts between components to serve as thermal barriers. The thickness of these inserts greatly affects heat transfer through the frame. For aluminum frames without the plastic strips, the primary resistance to heat transfer is due to the interior surface heat transfer coefficient. The U -factors for various frames are listed in Table 16-17 as a function of spacer materials and the glazing unit thicknesses. Note that the U -factor of metal framing and thus the rate of heat transfer through a metal window frame is more than three times that of a wood or vinyl window frame.

TABLE 16-17

Representative frame U -factors for fixed vertical windows (from ASHRAE Handbook of Fundamentals, Chap. 27, Table 2)

Frame material	U -factor, $W/m^2 \cdot ^\circ C$
Aluminum:	
Single glazing (3 mm)	10.1
Double glazing (18 mm)	10.1
Triple glazing (33 mm)	10.1
Wood or vinyl:	
Single glazing (3 mm)	2.9
Double glazing (18 mm)	2.8
Triple glazing (33 mm)	2.7

Interior and Exterior Surface Heat Transfer Coefficients

Heat transfer through a window is also affected by the convection and radiation heat transfer coefficients between the glass surfaces and surroundings. The effects of convection and radiation on the inner and outer surfaces of glazings are usually combined into the combined convection and radiation heat

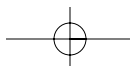

transfer coefficients h_i and h_o , respectively. Under still air conditions, the combined heat transfer coefficient at the inner surface of a vertical window can be determined from

$$h_i = h_{\text{conv}} + h_{\text{rad}} = 1.77(T_g - T_i)^{0.25} + \frac{\varepsilon_g \sigma (T_g^4 - T_i^4)}{T_g - T_i} \quad (\text{W/m}^2 \cdot ^\circ\text{C}) \quad (16-37)$$

where T_g = glass temperature in K, T_i = indoor air temperature in K, ε_g = emissivity of the inner surface of the glass exposed to the room (taken to be 0.84 for uncoated glass), and $\sigma = 5.67 \times 10^{-8} \text{ W/m}^2 \cdot \text{K}^4$ is the Stefan–Boltzmann constant. Here the temperature of the interior surfaces facing the window is assumed to be equal to the indoor air temperature. This assumption is reasonable when the window faces mostly interior walls, but it becomes questionable when the window is exposed to heated or cooled surfaces or to other windows. The commonly used value of h_i for peak load calculation is

$$h_i = 8.29 \text{ W/m}^2 \cdot ^\circ\text{C} \quad (\text{winter and summer})$$

which corresponds to the winter design conditions of $T_i = 22^\circ\text{C}$ and $T_g = -7^\circ\text{C}$ for uncoated glass with $\varepsilon_g = 0.84$. But the same value of h_i can also be used for summer design conditions as it corresponds to summer conditions of $T_i = 24^\circ\text{C}$ and $T_g = 32^\circ\text{C}$. The values of h_i for various temperatures and glass emissivities are given in Table 16–18. The commonly used values of h_o for peak load calculations are the same as those used for outer wall surfaces ($34.0 \text{ W/m}^2 \cdot ^\circ\text{C}$ for winter and $22.7 \text{ W/m}^2 \cdot ^\circ\text{C}$ for summer).

Overall U -Factor of Windows

The overall U -factors for various kinds of windows and skylights are evaluated using computer simulations and laboratory testing for winter design conditions; representative values are given in Table 16–19. Test data may provide more accurate information for specific products and should be preferred when available. However, the values listed in the table can be used to obtain satisfactory results under various conditions in the absence of product-specific data. The U -factor of a fenestration product that differs considerably from the ones in the table can be determined by (1) determining the fractions of the area that are frame, center-of-glass, and edge-of-glass (assuming a 65-mm-wide band around the perimeter of each glazing), (2) determining the U -factors for each section (the center-of-glass and edge-of-glass U -factors can be taken from the first two columns of Table 16–19 and the frame U -factor can be taken from Table 16–18 or other sources), and (3) multiplying the area fractions and the U -factors for each section and adding them up (or from Eq. 16–34 for U_{window}).

Glazed wall systems can be treated as fixed windows. Also, the data for double-door windows can be used for single-glass doors. Several observations can be made from the data in the table:

1. Skylight U -factors are considerably greater than those of vertical windows. This is because the skylight area, including the curb, can be 13 to 240 percent greater than the rough opening area. The slope of the skylight also has some effect.

TABLE 16–18

Combined convection and radiation heat transfer coefficient h_i at the inner surface of a vertical glass under still air conditions (in $\text{W/m}^2 \cdot ^\circ\text{C}$)

T_i , $^\circ\text{C}$	T_o , $^\circ\text{C}$	Glass emissivity, ε_g		
		0.05	0.20	0.84
20	17	2.6	3.5	7.1
20	15	2.9	3.8	7.3
20	10	3.4	4.2	7.7
20	5	3.7	4.5	7.9
20	0	4.0	4.8	8.1
20	–5	4.2	5.0	8.2
20	–10	4.4	5.1	8.3

TABLE 16-19

Overall U -factors (heat transfer coefficients) for various windows and skylights in $W/m^2 \cdot ^\circ C$ (from ASHRAE *Handbook of Fundamentals*, Chap. 27, Table 5)

Type	Glass section (glazing) only			Aluminum frame (without thermal break)			Wood or vinyl frame					
	Center- of-glass	Edge-of- glass		Fixed	Double door	Sloped skylight	Fixed		Double door		Sloped skylight	
Frame width →	(Not applicable)			32 mm (1¼ in)	53 mm (2 in)	19 mm (¾ in)	41 mm (1⅝ in)		88 mm (3⅞ in)		23 mm (⅞ in)	
Spacer type →	—	Metal	Insul.	All	All	All	Metal	Insul.	Metal	Insul.	Metal	Insul.
Glazing Type												
Single Glazing												
3 mm (⅛ in) glass	6.30	6.30	—	6.63	7.16	9.88	5.93	—	5.57	—	7.57	—
6.4 mm (¼ in) acrylic	5.28	5.28	—	5.69	6.27	8.86	5.02	—	4.77	—	6.57	—
3 mm (⅛ in) acrylic	5.79	5.79	—	6.16	6.71	9.94	5.48	—	5.17	—	7.63	—
Double Glazing (no coating)												
6.4 mm air space	3.24	3.71	3.34	3.90	4.55	6.70	3.26	3.16	3.20	3.09	4.37	4.22
12.7 mm air space	2.78	3.40	2.91	3.51	4.18	6.65	2.88	2.76	2.86	2.74	4.32	4.17
6.4 mm argon space	2.95	3.52	3.07	3.66	4.32	6.47	3.03	2.91	2.98	2.87	4.14	3.97
12.7 mm argon space	2.61	3.28	2.76	3.36	4.04	6.47	2.74	2.61	2.73	2.60	4.14	3.97
Double Glazing [$\epsilon = 0.1$, coating on one of the surfaces of air space (surface 2 or 3, counting from the outside toward inside)]												
6.4 mm air space	2.44	3.16	2.60	3.21	3.89	6.04	2.59	2.46	2.60	2.47	3.73	3.53
12.7 mm air space	1.82	2.71	2.06	2.67	3.37	6.04	2.06	1.92	2.13	1.99	3.73	3.53
6.4 mm argon space	1.99	2.83	2.21	2.82	3.52	5.62	2.21	2.07	2.26	2.12	3.32	3.09
12.7 mm argon space	1.53	2.49	1.83	2.42	3.14	5.71	1.82	1.67	1.91	1.78	3.41	3.19
Triple Glazing (no coating)												
6.4 mm air space	2.16	2.96	2.35	2.97	3.66	5.81	2.34	2.18	2.36	2.21	3.48	3.24
12.7 mm air space	1.76	2.67	2.02	2.62	3.33	5.67	2.01	1.84	2.07	1.91	3.34	3.09
6.4 mm argon space	1.93	2.79	2.16	2.77	3.47	5.57	2.15	1.99	2.19	2.04	3.25	3.00
12.7 mm argon space	1.65	2.58	1.92	2.52	3.23	5.53	1.91	1.74	1.98	1.82	3.20	2.95
Triple Glazing [$\epsilon = 0.1$, coating on one of the surfaces of air spaces (surfaces 3 and 5, counting from the outside toward inside)]												
6.4 mm air space	1.53	2.49	1.83	2.42	3.14	5.24	1.81	1.64	1.89	1.73	2.92	2.66
12.7 mm air space	0.97	2.05	1.38	1.92	2.66	5.10	1.33	1.15	1.46	1.30	2.78	2.52
6.4 mm argon space	1.19	2.23	1.56	2.12	2.85	4.90	1.52	1.35	1.64	1.47	2.59	2.33
12.7 mm argon space	0.80	1.92	1.25	1.77	2.51	4.86	1.18	1.01	1.33	1.17	2.55	2.28

Notes:

(1) Multiply by 0.176 to obtain U -factors in $Btu/h \cdot ft^2 \cdot ^\circ F$.

(2) The U -factors in this table include the effects of surface heat transfer coefficients and are based on winter conditions of $-18^\circ C$ outdoor air and $21^\circ C$ indoor air temperature, with 24 km/h (15 mph) winds outdoors and zero solar flux. Small changes in indoor and outdoor temperatures will not affect the overall U -factors much. Windows are assumed to be vertical, and the skylights are tilted 20° from the horizontal with upward heat flow. Insulation spacers are wood, fiberglass, or butyl. Edge-of-glass effects are assumed to extend the 65-mm band around perimeter of each glazing. The product sizes are 1.2 m \times 1.8 m for fixed windows, 1.8 m \times 2.0 m for double-door windows, and 1.2 m \times 0.6 m for the skylights, but the values given can also be used for products of similar sizes. All data are based on 3-mm (⅜-in) glass unless noted otherwise.

- The U -factor of multiple-glazed units can be reduced considerably by filling cavities with argon gas instead of dry air. The performance of CO_2 -filled units is similar to those filled with argon. The U -factor can be reduced even further by filling the glazing cavities with krypton gas.
- Coating the glazing surfaces with low- e (low-emissivity) films reduces the U -factor significantly. For multiple-glazed units, it is adequate to coat one of the two surfaces facing each other.
- The thicker the air space in multiple-glazed units, the lower the U -factor, for a thickness of up to 13 mm of air space. For a specified number of glazings, the window with thicker air layers will have a lower U -factor. For a specified overall thickness of glazing, the higher the number of glazings, the lower the U -factor. Therefore, a triple-pane window with air spaces of 6.4 mm (two such air spaces) will have a lower U -value than a double-pane window with an air space of 12.7 mm.
- Wood or vinyl frame windows have a considerably lower U -value than comparable metal-frame windows. Therefore, wood or vinyl frame windows are called for in energy-efficient designs.

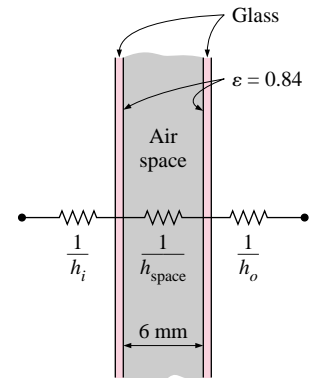

FIGURE 16-46
Schematic of Example 16-12.

EXAMPLE 16-12 U -Factor for Center-of-Glass Section of Windows

Determine the U -factor for the center-of-glass section of a double-pane window with a 6-mm air space for winter design conditions (Fig. 16-46). The glazings are made of clear glass that has an emissivity of 0.84. Take the average air space temperature at design conditions to be 0°C .

SOLUTION The U -factor for the center-of-glass section of a double-pane window is to be determined.

Assumptions 1 Steady operating conditions exist. 2 Heat transfer through the window is one-dimensional. 3 The thermal resistance of glass sheets is negligible.

Properties The emissivity of clear glass is 0.84.

Analysis Disregarding the thermal resistance of glass sheets, which are small, the U -factor for the center region of a double-pane window is determined from

$$\frac{1}{U_{\text{center}}} \cong \frac{1}{h_i} + \frac{1}{h_{\text{space}}} + \frac{1}{h_o}$$

where h_i , h_{space} , and h_o are the heat transfer coefficients at the inner surface of the window, the air space between the glass layers, and the outer surface of the window, respectively. The values of h_i and h_o for winter design conditions were given earlier to be $h_i = 8.29 \text{ W/m}^2 \cdot ^\circ\text{C}$ and $h_o = 34.0 \text{ W/m}^2 \cdot ^\circ\text{C}$. The effective emissivity of the air space of the double-pane window is

$$\varepsilon_{\text{effective}} = \frac{1}{1/\varepsilon_1 + 1/\varepsilon_2 - 1} = \frac{1}{1/0.84 + 1/0.84 - 1} = 0.72$$

For this value of emissivity and an average air space temperature of 0°C , we read $h_{\text{space}} = 7.2 \text{ W/m}^2 \cdot ^\circ\text{C}$ from Table 16-16 for 6-mm-thick air space. Therefore,

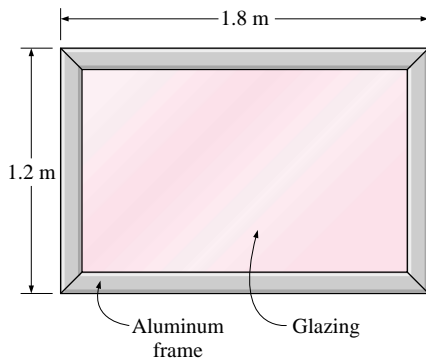

FIGURE 16-47
Schematic for Example 16-13.

$$\frac{1}{U_{\text{center}}} = \frac{1}{8.29} + \frac{1}{7.2} + \frac{1}{34.0} \rightarrow U_{\text{center}} = 3.46 \text{ W/m}^2 \cdot ^\circ\text{C}$$

Discussion The center-of-glass U -factor value of $3.24 \text{ W/m}^2 \cdot ^\circ\text{C}$ in Table 16-19 (fourth row and second column) is obtained by using a standard value of $h_o = 29 \text{ W/m}^2 \cdot ^\circ\text{C}$ (instead of $34.0 \text{ W/m}^2 \cdot ^\circ\text{C}$) and $h_{\text{space}} = 6.5 \text{ W/m}^2 \cdot ^\circ\text{C}$ at an average air space temperature of -15°C .

Example 16-13 Heat Loss through Aluminum-Framed Windows

A fixed aluminum-framed window with glass glazing is being considered for an opening that is 1.2 m high and 1.8 m wide in the wall of a house that is maintained at 22°C (Fig. 16-47). Determine the rate of heat loss through the window and the inner surface temperature of the window glass facing the room when the outdoor air temperature is -9°C if the window is selected to be (a) 3-mm single glazing, (b) double glazing with an air space of 12.7-mm, and (c) low-e-coated triple glazing with an air space of 12.7-mm.

SOLUTION The rate of heat loss through an aluminum-framed window and the inner surface temperature are to be determined from the cases of single-pane, double-pane, and low-e triple-pane windows.

Assumptions 1 Steady operating conditions exist. 2 Heat transfer through the window is one-dimensional. 3 Thermal properties of the windows and the heat transfer coefficients are constant.

Properties The U -factors of the windows are given in Table 16-19.

Analysis The rate of heat transfer through the window can be determined from

$$\dot{Q}_{\text{window}} = U_{\text{overall}} A_{\text{window}} (T_i - T_o)$$

where T_i and T_o are the indoor and outdoor air temperatures, respectively; U_{overall} is the U -factor (the overall heat transfer coefficient) of the window; and A_{window} is the window area, which is determined to be

$$A_{\text{window}} = \text{Height} \times \text{Width} = (1.2 \text{ m})(1.8 \text{ m}) = 2.16 \text{ m}^2$$

The U -factors for the three cases can be determined directly from Table 16-19 to be 6.63, 3.51, and $1.92 \text{ W/m}^2 \cdot ^\circ\text{C}$, respectively. Also, the inner surface temperature of the window glass can be determined from

$$\dot{Q}_{\text{window}} = h_i A_{\text{window}} (T_i - T_{\text{glass}}) \rightarrow T_{\text{glass}} = T_i - \frac{\dot{Q}_{\text{window}}}{h_i A_{\text{window}}}$$

where h_i is the heat transfer coefficient on the inner surface of the window, which is determined from Table 16-18 to be $h_i = 8.3 \text{ W/m}^2 \cdot ^\circ\text{C}$. Then the rate of heat loss and the interior glass temperature for each case are determined as follows:

(a) Single glazing:

$$\dot{Q}_{\text{window}} = (6.63 \text{ W/m}^2 \cdot ^\circ\text{C})(2.16 \text{ m}^2)[22 - (-9)]^\circ\text{C} = 444 \text{ W}$$

$$T_{\text{glass}} = T_i - \frac{\dot{Q}_{\text{window}}}{h_i A_{\text{window}}} = 22^\circ\text{C} - \frac{444 \text{ W}}{(8.3 \text{ W/m}^2 \cdot ^\circ\text{C})(2.16 \text{ m}^2)} = -2.8^\circ\text{C}$$

(b) Double glazing (12.7 mm air space):

$$\dot{Q}_{\text{window}} = (3.51 \text{ W/m}^2 \cdot ^\circ\text{C})(2.16 \text{ m}^2)[22 - (-9)]^\circ\text{C} = \mathbf{235 \text{ W}}$$

$$T_{\text{glass}} = T_i - \frac{\dot{Q}_{\text{window}}}{h_i A_{\text{window}}} = 22^\circ\text{C} - \frac{235 \text{ W}}{(8.3 \text{ W/m}^2 \cdot ^\circ\text{C})(2.16 \text{ m}^2)} = \mathbf{8.9^\circ\text{C}}$$

(c) Triple glazing (12.7 mm air space, low-e coated):

$$\dot{Q}_{\text{window}} = (1.92 \text{ W/m}^2 \cdot ^\circ\text{C})(2.16 \text{ m}^2)[22 - (-9)]^\circ\text{C} = \mathbf{129 \text{ W}}$$

$$T_{\text{glass}} = T_i - \frac{\dot{Q}_{\text{window}}}{h_i A_{\text{window}}} = 22^\circ\text{C} - \frac{129 \text{ W}}{(8.3 \text{ W/m}^2 \cdot ^\circ\text{C})(2.16 \text{ m}^2)} = \mathbf{14.8^\circ\text{C}}$$

Therefore, heat loss through the window will be reduced by 47 percent in the case of double glazing and by 71 percent in the case of triple glazing relative to the single-glazing case. Also, in the case of single glazing, the low inner-glass surface temperature will cause considerable discomfort in the occupants because of the excessive heat loss from the body by radiation. It is raised from -2.8°C , which is below freezing, to 8.9°C in the case of double glazing and to 14.8°C in the case of triple glazing.

EXAMPLE 16-14 U-Factor of a Double-Door Window

Determine the overall U -factor for a double-door-type, wood-framed double-pane window with metal spacers, and compare your result to the value listed in Table 16-19. The overall dimensions of the window are $1.80 \text{ m} \times 2.00 \text{ m}$, and the dimensions of each glazing are $1.72 \text{ m} \times 0.94 \text{ m}$ (Fig. 16-48).

SOLUTION The overall U -factor for a double-door type window is to be determined and the result is to be compared to the tabulated value.

Assumptions 1 Steady operating conditions exist. 2 Heat transfer through the window is one-dimensional.

Properties The U -factors for the various sections of windows are given in Tables 16-17 and 16-19.

Analysis The areas of the window, the glazing, and the frame are

$$A_{\text{window}} = \text{Height} \times \text{Width} = (1.8\text{ m})(2.0\text{ m}) = 3.60\text{ m}^2$$

$$A_{\text{glazing}} = 2 \times (\text{Height} \times \text{Width}) = 2(1.72\text{ m})(0.94\text{ m}) = 3.23\text{ m}^2$$

$$A_{\text{frame}} = A_{\text{window}} - A_{\text{glazing}} = 3.60 - 3.23 = 0.37\text{ m}^2$$

The edge-of-glass region consists of a 6.5-cm-wide band around the perimeter of the glazings, and the areas of the center and edge sections of the glazing are determined to be

$$A_{\text{center}} = 2 \times (\text{Height} \times \text{Width}) = 2(1.72 - 0.13\text{ m})(0.94 - 0.13\text{ m}) = 2.58\text{ m}^2$$

$$A_{\text{edge}} = A_{\text{glazing}} - A_{\text{center}} = 3.23 - 2.58 = 0.65\text{ m}^2$$

The U -factor for the frame section is determined from Table 16-17 to be $U_{\text{frame}} = 2.8 \text{ W/m}^2 \cdot ^\circ\text{C}$. The U -factors for the center and edge sections are

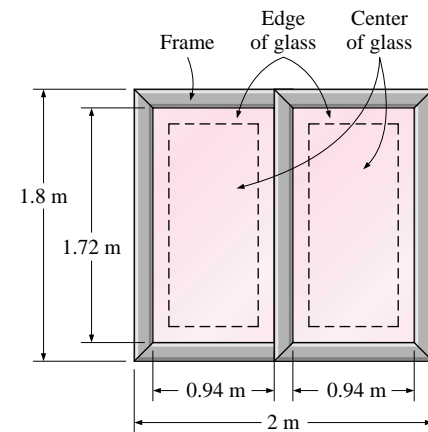

FIGURE 16-48
Schematic for Example 16-14.

determined from Table 16-19 (fifth row, second and third columns) to be $U_{\text{center}} = 3.24 \text{ W/m}^2 \cdot ^\circ\text{C}$ and $U_{\text{edge}} = 3.71 \text{ W/m}^2 \cdot ^\circ\text{C}$. Then the overall U -factor of the entire window becomes

$$\begin{aligned} U_{\text{window}} &= (U_{\text{center}}A_{\text{center}} + U_{\text{edge}}A_{\text{edge}} + U_{\text{frame}}A_{\text{frame}})/A_{\text{window}} \\ &= (3.24 \times 2.58 + 3.71 \times 0.65 + 2.8 \times 0.37)/3.60 \\ &= \mathbf{3.28 \text{ W/m}^2 \cdot ^\circ\text{C}} \end{aligned}$$

The overall U -factor listed in Table 16-19 for the specified type of window is $3.20 \text{ W/m}^2 \cdot ^\circ\text{C}$, which is sufficiently close to the value obtained above.

16-9 ■ SOLAR HEAT GAIN THROUGH WINDOWS

The sun is the primary heat source of the earth, and the solar irradiance on a surface normal to the sun's rays beyond the earth's atmosphere at the mean earth-sun distance of 149.5 million km is called the **solar constant**. The accepted value of the solar constant is 1373 W/m^2 , but its value changes by 3.5 percent from a maximum of 1418 W/m^2 on January 3 when the earth is farthest away from the sun, to a minimum of 1325 W/m^2 on July 4 when the earth is closest to the sun. The spectral distribution of solar radiation beyond the earth's atmosphere resembles the energy emitted by a blackbody at 5782°C , with about 9 percent of the energy contained in the ultraviolet region (at wavelengths between 0.29 to $0.4 \mu\text{m}$), 39 percent in the visible region (0.4 to $0.7 \mu\text{m}$), and the remaining 52 percent in the near-infrared region (0.7 to $3.5 \mu\text{m}$). The peak radiation occurs at a wavelength of about $0.48 \mu\text{m}$, which corresponds to the green color portion of the visible spectrum. Obviously a glazing material that transmits the visible part of the spectrum while absorbing the infrared portion is ideally suited for an application that calls for maximum daylight and minimum solar heat gain. Surprisingly, the ordinary window glass approximates this behavior remarkably well (Fig. 16-49).

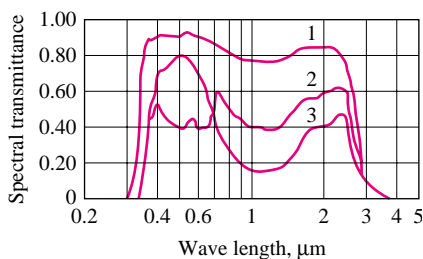

1. 3 mm regular sheet
2. 6 mm gray heat-absorbing plate/float
3. 6 mm green heat-absorbing plate/float

FIGURE 16-49

The variation of the transmittance of typical architectural glass with wavelength. (From ASHRAE Handbook of Fundamentals, Chap. 27, Fig. 11.)

Part of the solar radiation entering the earth's atmosphere is scattered and absorbed by air and water vapor molecules, dust particles, and water droplets in the clouds, and thus the solar radiation incident on earth's surface is less than the solar constant. The extent of the attenuation of solar radiation depends on the length of the path of the rays through the atmosphere as well as the composition of the atmosphere (the clouds, dust, humidity, and smog) along the path. Most ultraviolet radiation is absorbed by the ozone in the upper atmosphere. At a solar altitude of 41.8° , the total energy of direct solar radiation incident at sea level on a clear day consists of about 3 percent ultraviolet, 38 percent visible, and 59 percent infrared radiation.

The part of solar radiation that reaches the earth's surface without being scattered or absorbed is the direct radiation. Solar radiation that is scattered or reemitted by the constituents of the atmosphere is the diffuse radiation. Direct radiation comes directly from the sun following a straight path, whereas diffuse radiation comes from all directions in the sky. The entire radiation reaching the ground on an overcast day is diffuse radiation. The radiation reaching a surface, in general, consists of three components: direct radiation, diffuse radiation, and

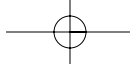

radiation reflected onto the surface from surrounding surfaces (Fig. 16-50). Common surfaces such as grass, trees, rocks, and concrete reflect about 20 percent of the radiation while absorbing the rest. Snow-covered surfaces, however, reflect 70 percent of the incident radiation. Radiation incident on a surface that does not have a direct view of the sun consists of diffuse and reflected radiation. Therefore, at solar noon, solar radiations incident on the east, west, and north surfaces of a south-facing house are identical since they all consist of diffuse and reflected components. The difference between the radiations incident on the south and north walls in this case gives the magnitude of direct radiation incident on the south wall.

When solar radiation strikes a glass surface, part of it (about 8 percent for uncoated clear glass) is reflected back to outdoors, part of it (5 to 50 percent, depending on composition and thickness) is absorbed within the glass, and the remainder is transmitted indoors, as shown in Fig. 16-51. The conservation of energy principle requires that the sum of the transmitted, reflected, and absorbed solar radiations be equal to the incident solar radiation. That is,

$$\tau_s + \rho_s + \alpha_s = 1$$

where τ_s is the transmissivity, ρ_s is the reflectivity, and α_s is the absorptivity of the glass for solar energy, which are the fractions of incident solar radiation transmitted, reflected, and absorbed, respectively. The standard 3-mm- ($\frac{1}{8}$ -in) thick single-pane double-strength clear window glass transmits 86 percent, reflects 8 percent, and absorbs 6 percent of the solar energy incident on it. The radiation properties of materials are usually given for normal incidence, but can also be used for radiation incident at other angles since the transmissivity, reflectivity, and absorptivity of the glazing materials remain essentially constant for incidence angles up to about 60° from the normal.

The hourly variation of solar radiation incident on the walls and windows of a house is given in Table 16-20. Solar radiation that is transmitted indoors is partially absorbed and partially reflected each time it strikes a surface, but all of it is eventually absorbed as sensible heat by the furniture, walls, people, and so forth. Therefore, the solar energy transmitted inside a building represents a heat gain for the building. Also, the solar radiation absorbed by the glass is subsequently transferred to the indoors and outdoors by convection and radiation. The sum of the *transmitted* solar radiation and the portion of the *absorbed* radiation that flows indoors constitutes the **solar heat gain** of the building.

The fraction of incident solar radiation that enters through the glazing is called the **solar heat gain coefficient SHGC** and is expressed as

$$\begin{aligned} \text{SHGC} &= \frac{\text{Solar heat gain through the window}}{\text{Solar radiation incident on the window}} && (16-38) \\ &= \frac{\dot{q}_{\text{solar, gain}}}{\dot{q}_{\text{solar, incident}}} = \tau + f_i \alpha_s \end{aligned}$$

where α_s is the solar absorptivity of the glass and f_i is the inward flowing fraction of the solar radiation absorbed by the glass. Therefore, the dimensionless quantity SHGC is the sum of the fractions of the directly transmitted (τ_s) and

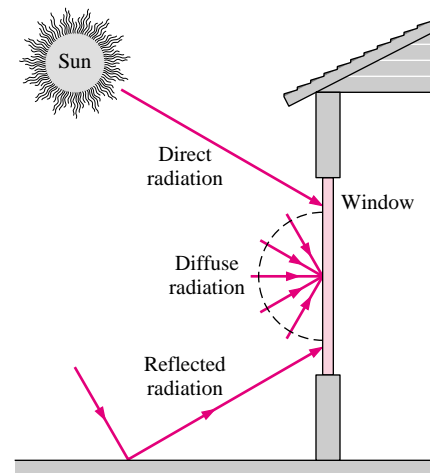

FIGURE 16-50
Direct, diffuse, and reflected components of solar radiation incident on a window.

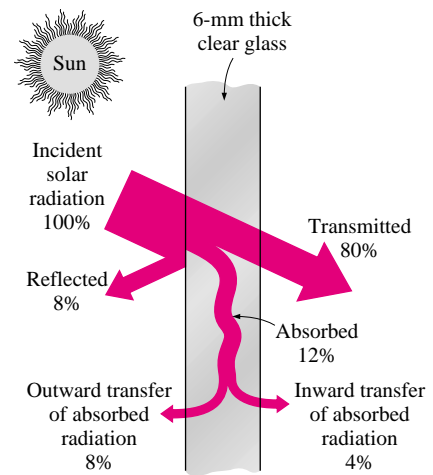

FIGURE 16-51
Distribution of solar radiation incident on a clear glass.

TABLE 16-20

Hourly variation of solar radiation incident on various surfaces and the daily totals throughout the year at 40° latitude
(from ASHRAE *Handbook of Fundamentals*, Chap. 27, Table 15)

		Solar radiation incident on the surface, W/m ²															Daily total
Date	Direction of surface	Solar time															
		5	6	7	8	9	10	11	12 noon	13	14	15	16	17	18	19	
Jan.	N	0	0	0	20	43	66	68	71	68	66	43	20	0	0	0	446
	NE	0	0	0	63	47	66	68	71	68	59	43	20	0	0	0	489
	E	0	0	0	402	557	448	222	76	68	59	43	20	0	0	0	1863
	SE	0	0	0	483	811	875	803	647	428	185	48	20	0	0	0	4266
	S	0	0	0	271	579	771	884	922	884	771	579	271	0	0	0	5897
	SW	0	0	0	20	48	185	428	647	803	875	811	483	0	0	0	4266
	W	0	0	0	20	43	59	68	76	222	448	557	402	0	0	0	1863
	NW	0	0	0	20	43	59	68	71	68	66	47	63	0	0	0	489
	Horizontal	0	0	0	51	198	348	448	482	448	348	198	51	0	0	0	2568
Direct	0	0	0	446	753	865	912	926	912	865	753	446	0	0	0	—	
Apr.	N	0	41	57	79	97	110	120	122	120	110	97	79	57	41	0	1117
	NE	0	262	508	462	291	134	123	122	120	110	97	77	52	17	0	2347
	E	0	321	728	810	732	552	293	131	120	110	97	77	52	17	0	4006
	SE	0	189	518	682	736	699	582	392	187	116	97	77	52	17	0	4323
	S	0	18	59	149	333	437	528	559	528	437	333	149	59	18	0	3536
	SW	0	17	52	77	97	116	187	392	582	699	736	682	518	189	0	4323
	W	0	17	52	77	97	110	120	392	293	552	732	810	728	321	0	4006
	NW	0	17	52	77	97	110	120	122	123	134	291	462	508	262	0	2347
	Horizontal	0	39	222	447	640	786	880	911	880	786	640	447	222	39	0	6938
Direct	0	282	651	794	864	901	919	925	919	901	864	794	651	282	0	—	
July	N	3	133	109	103	117	126	134	138	134	126	117	103	109	133	3	1621
	NE	8	454	590	540	383	203	144	138	134	126	114	95	71	39	0	3068
	E	7	498	739	782	701	531	294	149	134	126	114	95	71	39	0	4313
	SE	2	248	460	580	617	576	460	291	155	131	114	95	71	39	0	3849
	S	0	39	76	108	190	292	369	395	369	292	190	108	76	39	0	2552
	SW	0	39	71	95	114	131	155	291	460	576	617	580	460	248	2	3849
	W	0	39	71	95	114	126	134	149	294	531	701	782	739	498	7	4313
	NW	0	39	71	95	114	126	134	138	144	203	383	540	590	454	8	3068
	Horizontal	1	115	320	528	702	838	922	949	922	838	702	528	320	115	1	3902
Direct	7	434	656	762	818	850	866	871	866	850	818	762	656	434	7	—	
Oct.	N	0	0	7	40	62	77	87	90	87	77	62	40	7	0	0	453
	NE	0	0	74	178	84	80	87	90	87	87	62	40	7	0	0	869
	E	0	0	163	626	652	505	256	97	87	87	62	40	7	0	0	2578
	SE	0	0	152	680	853	864	770	599	364	137	66	40	7	0	0	4543
	S	0	0	44	321	547	711	813	847	813	711	547	321	44	0	0	5731
	SW	0	0	7	40	66	137	364	599	770	864	853	680	152	0	0	4543
	W	0	0	7	40	62	87	87	97	256	505	652	626	163	0	0	2578
	NW	0	0	7	40	62	87	87	90	87	80	84	178	74	0	0	869
	Horizontal	0	0	14	156	351	509	608	640	608	509	351	156	14	0	0	3917
Direct	0	0	152	643	811	884	917	927	917	884	811	643	152	0	0	—	



the absorbed and reemitted ($f_r\alpha_s$) portions of solar radiation incident on the window. The value of SHGC ranges from 0 to 1, with 1 corresponding to an opening in the wall (or the ceiling) with no glazing. When the SHGC of a window is known, the total solar heat gain through that window is determined from

$$\dot{Q}_{\text{solar, gain}} = \text{SHGC} \times A_{\text{glazing}} \times \dot{q}_{\text{solar, incident}} \quad (\text{W}) \quad (16-39)$$

where A_{glazing} is the glazing area of the window and $\dot{q}_{\text{solar, incident}}$ is the solar heat flux incident on the outer surface of the window, in W/m^2 .

Another way of characterizing the solar transmission characteristics of different kinds of glazing and shading devices is to compare them to a well known glazing material that can serve as a base case. This is done by taking the standard 3-mm-thick double-strength clear window glass sheet whose SHGC is 0.87 as the *reference glazing* and defining a **shading coefficient SC** as

$$\begin{aligned} \text{SC} &= \frac{\text{Solar heat gain of product}}{\text{Solar heat gain of reference glazing}} \\ &= \frac{\text{SHGC}}{\text{SHGC}_{\text{ref}}} = \frac{\text{SHGC}}{0.87} = 1.15 \times \text{SHGC} \end{aligned} \quad (16-40)$$

Therefore, the shading coefficient of a single-pane clear glass window is $\text{SC} = 1.0$. The shading coefficients of other commonly used fenestration products are given in Table 16–21 for summer design conditions. The values for winter design conditions may be slightly lower because of the higher heat transfer coefficients on the outer surface due to high winds and thus higher rate of outward flow of solar heat absorbed by the glazing, but the difference is small.

Note that the larger the shading coefficient, the smaller the shading effect, and thus the larger the amount of solar heat gain. A glazing material with a large shading coefficient allows a large fraction of solar radiation to come in.

Shading devices are classified as *internal shading* and *external shading*, depending on whether the shading device is placed *inside* or *outside*. External shading devices are more effective in reducing the solar heat gain since they intercept the sun’s rays before they reach the glazing. The solar heat gain through a window can be reduced by as much as 80 percent by exterior shading. Roof overhangs have long been used for exterior shading of windows. The sun is high in the horizon in summer and low in winter. A properly sized roof overhang or a horizontal projection blocks off the sun’s rays completely in summer while letting in most of them in winter, as shown in Fig. 16–52. Such shading structures can reduce the solar heat gain on the south, southeast, and southwest windows in the northern hemisphere considerably. A window can also be shaded from outside by vertical or horizontal or architectural

Notes on Table 16–20: Values given are for the 21st of the month for average days with no clouds. The values can be up to 15 percent higher at high elevations under very clear skies and up to 30 percent lower at very humid locations with very dusty industrial atmospheres. Daily totals are obtained using Simpson’s rule for integration with 10-minute time intervals. Solar reflectance of the ground is assumed to be 0.2, which is valid for old concrete, crushed rock, and bright green grass. For a specified location, use solar radiation data obtained for that location. The direction of a surface indicates the direction a vertical surface is facing. For example, W represent the solar radiation incident on a west-facing wall per unit area of the wall.

Solar time may deviate from the local time. Solar noon at a location is the time when the sun is at the highest location (and thus when the shadows are shortest). Solar radiation data are symmetric about the solar noon: the value on a west wall two hours before the solar noon is equal to the value on an east wall two hours after the solar noon.

TABLE 16–21

Shading coefficient SC and solar transmissivity τ_{solar} for some common glass types for summer design conditions (from ASHRAE *Handbook of Fundamentals*, Chap. 27, Table 11)

Type of glazing	Nominal thickness		τ_{solar}	SC*
	mm	in		
<i>(a) Single Glazing</i>				
Clear	3	$\frac{1}{8}$	0.86	1.0
	6	$\frac{1}{4}$	0.78	0.95
	10	$\frac{3}{8}$	0.72	0.92
	13	$\frac{1}{2}$	0.67	0.88
Heat absorbing	3	$\frac{1}{8}$	0.64	0.85
	6	$\frac{1}{4}$	0.46	0.73
	10	$\frac{3}{8}$	0.33	0.64
	13	$\frac{1}{2}$	0.24	0.58
<i>(b) Double Glazing</i>				
Clear in,	3 ^a	$\frac{1}{8}$	0.71 ^b	0.88
clear out	6	$\frac{1}{4}$	0.61	0.82
Clear in,				
heat absorbing out ^c	6	$\frac{1}{4}$	0.36	0.58

*Multiply by 0.87 to obtain SHGC.

^aThe thickness of each pane of glass.

^bCombined transmittance for assembled unit.

^cRefers to gray-, bronze-, and green-tinted heat-absorbing float glass.

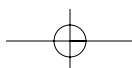
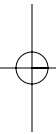
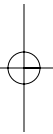

16-56
HEATING AND COOLING OF BUILDINGS

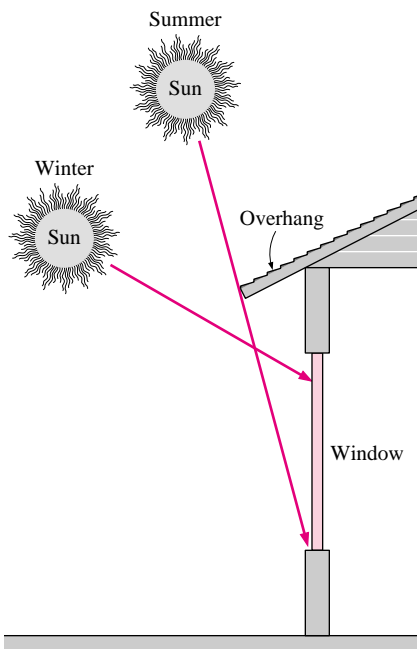

FIGURE 16-52

A properly sized overhang blocks off the sun's rays completely in summer while letting them in winter.

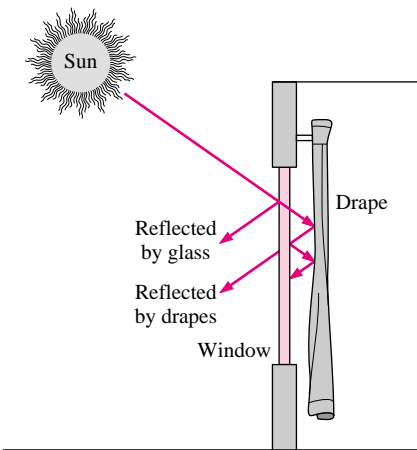

FIGURE 16-53

Draperies reduce heat gain in summer by reflecting back solar radiation, and reduce heat loss in winter by forming an air space before the window.

projections, insect or shading screens, and sun screens. To be effective, air must be able to move freely around the exterior device to carry away the heat absorbed by the shading and the glazing materials.

Some type of internal shading is used in most windows to provide privacy and aesthetic effects as well as some control over solar heat gain. Internal shading devices reduce solar heat gain by reflecting transmitted solar radiation back through the glazing before it can be absorbed and converted into heat in the building.

Draperies reduce the annual heating and cooling loads of a building by 5 to 20 percent, depending on the type and the user habits. In summer, they reduce heat gain primarily by reflecting back direct solar radiation (Fig. 16-53). The semiclosed air space formed by the draperies serves as an additional barrier against heat transfer, resulting in a lower U -factor for the window and thus a lower rate of heat transfer in summer and winter. The solar optical properties of draperies can be measured accurately, or they can be obtained directly from the manufacturers. The shading coefficient of draperies depends on the openness factor, which is the ratio of the open area between the fibers that permits the sun's rays to pass freely, to the total area of the fabric. Tightly woven fabrics allow little direct radiation to pass through, and thus they have a small openness factor. The *reflectance* of the surface of the drapery facing the glazing has a major effect on the amount of solar heat gain. *Light-colored* draperies made of closed or tightly woven fabrics maximize the back reflection and thus minimize the solar gain. *Dark-colored* draperies made of open or semi-open woven fabrics, on the other hand, minimize the back reflection and thus maximize the solar gain.

The shading coefficients of drapes also depend on the way they are hung. Usually, the width of drapery used is twice the width of the draped area to allow folding of the drapes and to give them their characteristic "full" or "wavy" appearance. A flat drape behaves like an ordinary window shade. A flat drape has a higher reflectance and thus a lower shading coefficient than a full drape.

External shading devices such as overhangs and tinted glazings do not require operation, and provide reliable service over a long time without significant degradation during their service life. Their operation does not depend on a person or an automated system, and these passive shading devices are considered fully effective when determining the peak cooling load and the annual energy use. The effectiveness of manually operated shading devices, on the other hand, varies greatly depending on the user habits, and this variation should be considered when evaluating performance.

The primary function of an indoor shading device is to provide *thermal comfort* for the occupants. An unshaded window glass allows most of the incident solar radiation in, and also dissipates part of the solar energy it absorbs by emitting infrared radiation to the room. The emitted radiation and the transmitted direct sunlight may bother the occupants near the window. In winter, the temperature of the glass is lower than the room air temperature, causing excessive heat loss by radiation from the occupants. A shading device allows the control of direct solar and infrared radiation while providing various degrees of privacy and outward vision. The shading device is also at a higher temperature than the glass in winter, and thus reduces radiation loss from occupants. *Glare* from draperies can be minimized by using off-white colors.

Indoor shading devices, especially draperies made of a closed-weave fabric, are effective in reducing *sounds* that originate in the room, but they are not as effective against the sounds coming from outside.

The type of climate in an area usually dictates the type of windows to be used in buildings. In *cold climates* where the heating load is much larger than the cooling load, the windows should have the highest transmissivity for the entire solar spectrum, and a high reflectivity (or low emissivity) for the far infrared radiation emitted by the walls and furnishings of the room. Low-e windows are well suited for such heating-dominated buildings. Properly designed and operated windows allow more heat into the building over a heating season than it loses, making them energy contributors rather than energy losers. In *warm climates* where the cooling load is much larger than the heating load, the windows should allow the visible solar radiation (light) in, but should block off the infrared solar radiation. Such windows can reduce the solar heat gain by 60 percent with no appreciable loss in daylighting. This behavior is approximated by window glazings that are coated with a heat-absorbing film outside and a low-e film inside (Fig. 16–54). Properly selected windows can reduce the cooling load by 15 to 30 percent compared to windows with clear glass.

Note that radiation heat transfer between a room and its windows is proportional to the emissivity of the glass surface facing the room, ϵ_{glass} , and can be expressed as

$$\dot{Q}_{\text{rad,room-window}} = \epsilon_{\text{glass}} A_{\text{glass}} \sigma (T_{\text{room}}^4 - T_{\text{glass}}^4)$$

Therefore, a low-e interior glass will reduce the heat loss by radiation in winter ($T_{\text{glass}} < T_{\text{room}}$) and heat gain by radiation in summer ($T_{\text{glass}} > T_{\text{room}}$).

Tinted glass and glass coated with reflective films reduce solar heat gain in summer and heat loss in winter. The conductive heat gains or losses can be minimized by using multiple-pane windows. Double-pane windows are usually called for in climates where the winter design temperature is less than 7°C (45°F). Double-pane windows with tinted or reflective films are commonly used in buildings with large window areas. Clear glass is preferred for showrooms since it affords maximum visibility from outside, but bronze-, gray-, and green-colored glass are preferred in office buildings since they provide considerable privacy while reducing glare.

EXAMPLE 16-15 Installing Reflective Films on Windows

A manufacturing facility located at 40°N latitude has a glazing area of 40 m² that consists of double-pane windows made of clear glass (SHGC = 0.766). To reduce the solar heat gain in summer, a reflective film that reduces the SHGC to 0.261 is considered. The cooling season consists of June, July, August, and September, and the heating season October through April. The average daily solar heat fluxes incident on the west side at this latitude are 1.86, 2.66, 3.43, 4.00, 4.36, 5.13, 4.31, 3.93, 3.28, 2.80, 1.84, and 1.54 kWh/day · m² for January through December, respectively. Also, the unit cost of electricity and natural gas are \$0.08/kWh and \$0.50/therm (1 therm = 29.31 kWh), respectively. If the coefficient of performance of the cooling system is 2.5 and efficiency of the furnace is 0.8, determine the net annual cost savings due to installing reflective coating on the windows. Also, determine the simple payback period if the installation cost of reflective film is \$20/m² (Fig. 16–55).

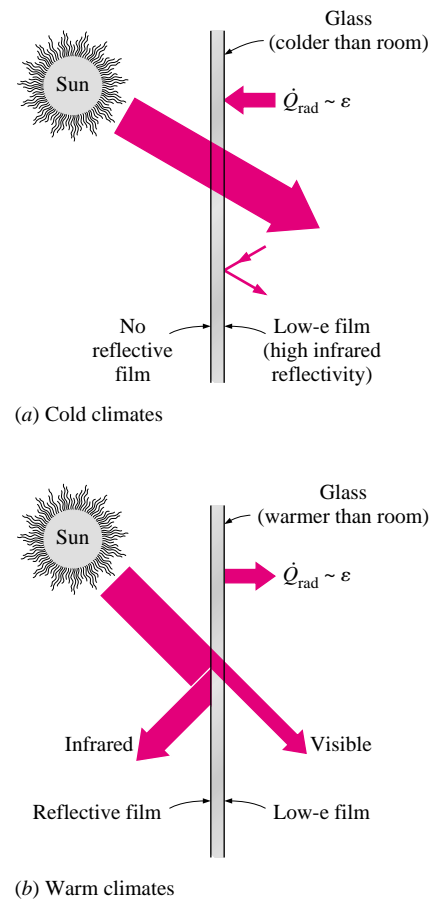

FIGURE 16-54

Radiation heat transfer between a room and its window is proportional to the emissivity of the glass surface, and low-e coatings on the inner surface of the windows reduce heat loss in winter and heat gain in summer.

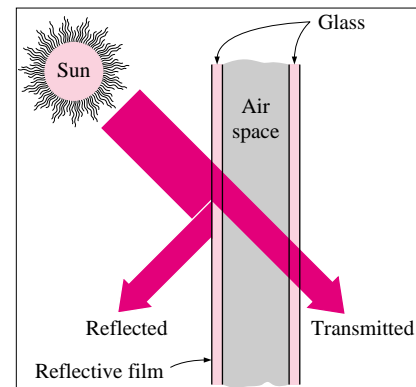

FIGURE 16-55

Schematic for Example 16-15.

SOLUTION The net annual cost savings due to installing reflective film on the west windows of a building and the simple payback period are to be determined.

Assumptions 1 The calculations given below are for an average year. 2 The unit costs of electricity and natural gas remain constant.

Analysis Using the daily averages for each month and noting the number of days of each month, the total solar heat flux incident on the glazing during summer and winter months are determined to be

$$\begin{aligned} Q_{\text{solar, summer}} &= 5.13 \times 30 + 4.31 \times 31 + 3.93 \times 31 + 3.28 \times 30 \\ &= 508 \text{ kWh/year} \end{aligned}$$

$$\begin{aligned} Q_{\text{solar, winter}} &= 2.80 \times 31 + 1.84 \times 30 + 1.54 \times 31 + 1.86 \times 31 \\ &\quad + 2.66 \times 28 + 3.43 \times 31 + 4.00 \times 30 \\ &= 548 \text{ kWh/year} \end{aligned}$$

Then the decrease in the annual cooling load and the increase in the annual heating load due to the reflective film become

$$\begin{aligned} \text{Cooling load decrease} &= Q_{\text{solar, summer}} A_{\text{glazing}} (\text{SHGC}_{\text{without film}} - \text{SHGC}_{\text{with film}}) \\ &= (508 \text{ kWh/year})(40 \text{ m}^2)(0.766 - 0.261) \\ &= 10,262 \text{ kWh/year} \end{aligned}$$

$$\begin{aligned} \text{Heating load increase} &= Q_{\text{solar, winter}} A_{\text{glazing}} (\text{SHGC}_{\text{without film}} - \text{SHGC}_{\text{with film}}) \\ &= (548 \text{ kWh/year})(40 \text{ m}^2)(0.766 - 0.261) \\ &= 11,070 \text{ kWh/year} = 377.7 \text{ therms/year} \end{aligned}$$

since 1 therm = 29.31 kWh. The corresponding decrease in cooling costs and the increase in heating costs are

$$\begin{aligned} \text{Decrease in cooling costs} &= (\text{Cooling load decrease}) \\ &\quad \times (\text{Unit cost of electricity})/\text{COP} \\ &= (10,262 \text{ kWh/year})(\$0.08/\text{kWh})/2.5 = \$328/\text{year} \end{aligned}$$

$$\begin{aligned} \text{Increase in heating costs} &= (\text{Heating load increase})(\text{Unit cost of fuel})/ \\ &\quad \text{Efficiency} \\ &= (377.7 \text{ therms/year})(\$0.50/\text{therm})/0.80 = \$236/\text{year} \end{aligned}$$

Then the net annual cost savings due to the reflective film become

$$\begin{aligned} \text{Cost savings} &= \text{Decrease in cooling costs} - \text{Increase in heating costs} \\ &= \$328 - \$236 = \mathbf{\$92/\text{year}} \end{aligned}$$

The implementation cost of installing films is

$$\text{Implementation cost} = (\$20/\text{m}^2)(40 \text{ m}^2) = \$800$$

This gives a simple payback period of

$$\text{Simple payback period} = \frac{\text{Implementation cost}}{\text{Annual cost saving}} = \frac{\$800}{\$92/\text{year}} = \mathbf{8.7 \text{ years}}$$

Discussion The reflective film will pay for itself in this case in about nine years. This may be unacceptable to most manufacturers since they are not usually interested in any energy conservation measure that does not pay for itself within three years. But the enhancement in thermal comfort and thus the resulting increase in productivity often makes it worthwhile to install reflective film

16-10 ■ INFILTRATION HEAT LOAD AND WEATHERIZING

Most older homes and some poorly constructed new ones have numerous cracks, holes, and openings through which cold outdoor air exchanges with the warm air inside a building in winter, and vice versa in summer. This uncontrolled entry of outside air into a building through unintentional openings is called infiltration, and it wastes a significant amount of energy since the air entering must be heated in winter and cooled in summer (Fig. 16-56). The warm air leaving the house represents energy loss. This is also the case for cool air leaving in summer since some electricity is used to cool that air. In homes that have not been properly weatherized, the air leaks account for about 30–40 percent of the total heat lost from the house in winter. That is, about one-third of the heating bill of such a house is due to the air leaks.

The rate of infiltration depends on the *wind velocity* and the *temperature difference* between the inside and the outside, and thus it varies throughout the year. The infiltration rates are much higher in winter than they are in summer because of the higher winds and larger temperature differences in winter. Therefore, distinction should be made between the *design infiltration rate* at design conditions, which is used to size heating or cooling equipment, and the *seasonal average infiltration rate*, which is used to properly estimate the seasonal energy consumption for heating or cooling. Infiltration appears to be providing “fresh outdoor air” to a building, but it is not a reliable ventilation mechanism since it depends on the weather conditions and the size and location of the cracks.

The air infiltration rate of a building can be determined by direct measurements by (1) *injecting a tracer gas* into a building and observing the decline of its concentration with time or (2) *pressurizing the building* to 10 to 75 Pa gage pressure by a large fan mounted on a door or window, and measuring the air flow required to maintain a specified indoor–outdoor pressure difference. The larger the air flow to maintain a pressure difference, the more the building may leak. Sulfur hexafluoride (SF_6) is commonly used as a tracer gas because it is inert, nontoxic, and easily detectable at concentrations as low as 1 part per billion. Pressurization testing is easier to conduct, and thus preferable to tracer gas testing. Pressurization test results for a whole house are given in Fig. 16-57.

Despite their accuracy, direct measurement techniques are inconvenient, expensive, and time consuming. A practical alternative is to *predict* the air infiltration rate on the basis of extensive data available on existing buildings. One way of predicting the air infiltration rate is by determining the type and size of all the cracks at all possible locations (around doors and windows, lighting fixtures, wall–floor joints, etc., as shown in Fig. 16-58), as well as the pressure differential across the cracks at specified conditions, and calculating the air flow rates. This is known as the **crack method**.

A simpler and more practical approach is to “estimate” how many times the entire air in a building is replaced by the outside air per hour on the basis of experience with similar buildings under similar conditions. This is called the **air-change method**, and the infiltration rate in this case is expressed in terms of **air changes per hour (ACH)**, defined as

$$\text{ACH} = \frac{\text{Flow rate of indoor air into the building (per hour)}}{\text{Internal volume of the building}} = \frac{\dot{V}(\text{m}^3/\text{h})}{V(\text{m}^3)} \quad (16-41)$$

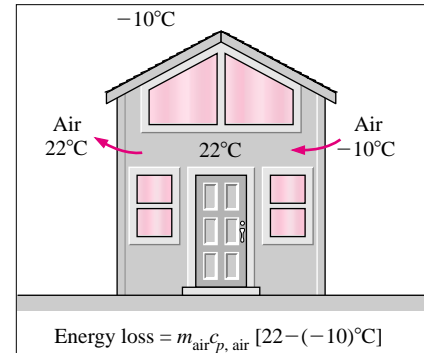

FIGURE 16-56

When cold outdoor air enters a building in winter, an equivalent amount of warm air must leave the house. This represents energy loss by infiltration.

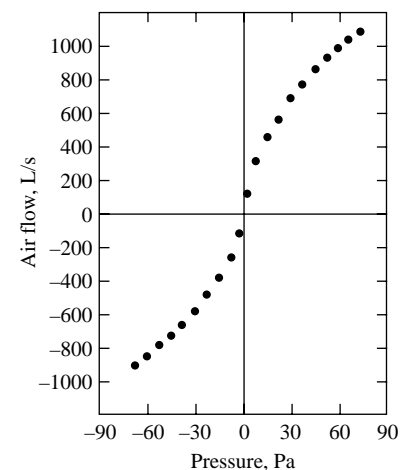
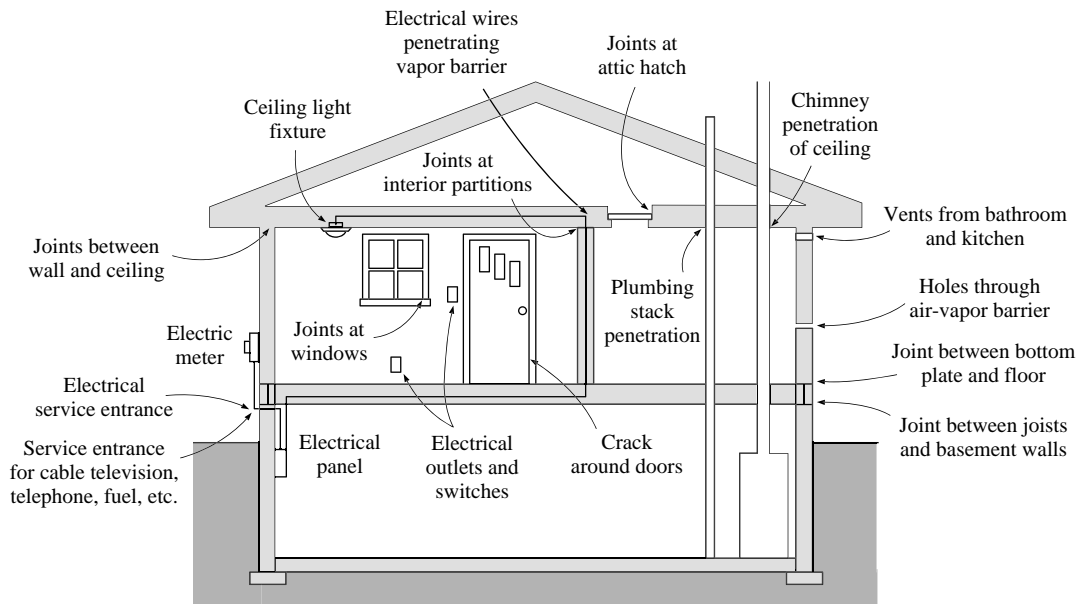

FIGURE 16-57

Typical data from a whole house pressurization test for the variation of air flow rate with pressure difference.

(From ASHRAE Handbook of Fundamentals, Chap. 23, Fig. 8.)

**FIGURE 16-58**

Typical air-leakage sites of a house.

(From U.S. Department of Energy pamphlet, FS 203, 1992.)

The mass of air corresponding to 1 ACH is determined from $m = \rho V$ where ρ is the density of air whose value is determined at the *outdoor* temperature and pressure. Therefore, the quantity ACH represents the number of building volumes of outdoor air that infiltrates (and eventually exfiltrates) per hour. At sea-level standard conditions of 1 atm (101.3 kPa or 14.7 psia) and 20°C, the density of air is

$$\rho_{\text{air, standard}} = 1.20 \text{ kg/m}^3$$

However, the atmospheric pressure and thus the density of air will drop by about 20 percent at 1500 m elevation at 20°C, and by about 10 percent when the temperature rises to 50°C at 1 atm pressure. Therefore, local air density should be used in calculations to avoid such errors.

Infiltration rate values for hundreds of buildings throughout the United States have been measured during the last two decades, and the seasonal average infiltration rates have been observed to vary from about 0.2 ACH for newer energy-efficient tight buildings to about 2.0 ACH for older buildings. Therefore, infiltration rates can easily vary by a factor of 10 from one building to another. Seasonal average infiltration rates as low as 0.02 have been recorded. A study that involved 312 mostly new homes determined the average infiltration rate to be about 0.5 ACH. Another study that involved 266 mostly older homes determined the average infiltration rate to be about 0.9 ACH. The infiltration rates of some new office buildings with no outdoor air intake are measured to be between 0.1 and 0.6 ACH. Occupancy is estimated to add 0.1 to 0.15 ACH to unoccupied infiltration rate values. Also, the infiltration rate of a building can vary by a factor of 5, depending on the weather.

A minimum of 0.35 ACH is required to meet the *fresh air requirements* of residential buildings and to maintain indoor air quality, provided that at least 7.5 L/s of fresh air is supplied per occupant to keep the indoor CO₂ concentra-



tion level below 1000 parts per million (0.1 percent). Usually the infiltration rates of houses are above 0.35 ACH, and thus we do not need to be concerned about *mechanical ventilation*. However, the infiltration rates of some of today's energy-efficient buildings are below the required minimum, and additional fresh air must be supplied to such buildings by mechanical ventilation. It may be necessary to install a central ventilating system in addition to the bathroom and kitchen fans to bring the air quality to desired levels.

Venting the cold outside air directly into the house will obviously increase the heating load in winter. But part of the energy in the warm air vented out can be recovered by installing an *air-to-air heat exchanger* (also called an “economizer” or “heat recuperator”) that transfers the heat from the exhausted stale air to the incoming fresh air without any mixing (Fig. 16–59). Such heat exchangers are commonly used in superinsulated houses, but the benefits of such heat exchangers must be weighed against the cost and complexity of their installation. The effectiveness of such heat exchangers is typically low (about 40 percent) because of the small temperature differences involved.

The primary cause of excessive infiltration is *poor workmanship*, but it may also be the settling and aging of the house. Infiltration is likely to develop where two surfaces meet such as the wall–foundation joint. Large differences between indoor and outdoor humidity and temperatures may aggravate the problem. Winds exert a dynamic pressure on the house, which forces the outside air through the cracks inside the house.

Infiltration should not be confused with **ventilation**, which is the *intentional* and *controlled* mechanism of air flow into or out of a building. Ventilation can be *natural* or *forced* (or *mechanical*), depending on how it is achieved. Ventilation accomplished by the opening of windows or doors is natural ventilation, whereas ventilation accomplished by an air mover such as a fan is forced ventilation. Forced ventilation gives the designer the greatest control over the magnitude and distribution of air flow throughout a building. The airtightness or air exchange rate of a building at any given time usually includes the effects of natural and forced ventilation as well as infiltration.

Air exchange, or the supply of fresh air, has a significant role on health, air quality, thermal comfort, and energy consumption. The *supply of fresh air* is a double-edged sword: too little of it will cause health and comfort problems such as the sick-building syndrome that was experienced in super-airtight buildings, and too much of it will waste energy. Therefore, the rate of fresh air supply should be just enough to maintain the indoor air quality at an acceptable level. The infiltration rate of older buildings is several times the required minimum flow rate of fresh air, and thus there is a high energy penalty associated with it.

Infiltration increases the *energy consumption* of a building in two ways: First, the incoming outdoor air must be heated (or cooled in summer) to the indoor air temperature. This represents the **sensible heat load** of infiltration and is expressed as

$$\begin{aligned}\dot{Q}_{\text{infiltration, sensible}} &= \rho_o c_p \dot{V}(T_i - T_o) \\ &= \rho_o c_p (\text{ACH})(V_{\text{building}})(T_i - T_o)\end{aligned}\quad (16-42)$$

where ρ_o is the density of outdoor air; c_p is the specific heat of air (about 1 kJ/kg · °C); $\dot{V} = (\text{ACH})(V_{\text{building}})$ is the volumetric flow rate of air, which is the number of air changes per hour times the volume of the building; and $T_i - T_o$ is the temperature difference between the indoor and outdoor air. Second, the moisture content of outdoor air, in general, is different

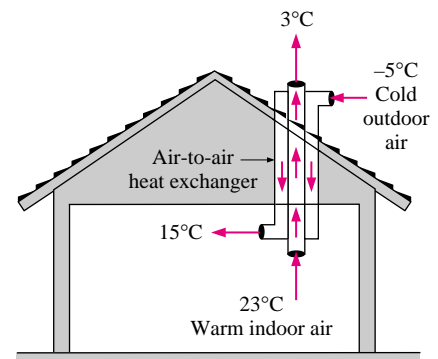
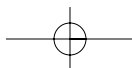
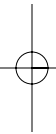
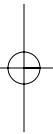

FIGURE 16–59

An air-to-air heat exchanger recuperates some of the energy of warm indoor air vented out of a building.



16-62
HEATING AND COOLING OF BUILDINGS

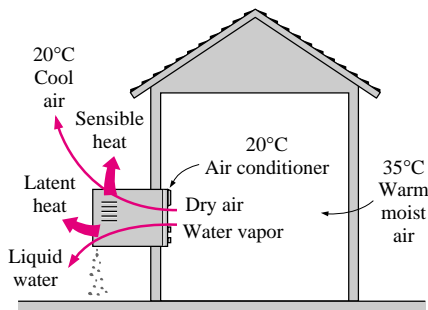

FIGURE 16-60

The energy removed while water vapor in the air is condensed constitutes the latent heat load of an air-conditioning system.

than that of indoor air, and thus the incoming air may need to be humidified or dehumidified. This represents the **latent heat load** of infiltration and is expressed as (Fig. 16-60)

$$\begin{aligned}\dot{Q}_{\text{infiltration, latent}} &= \rho_o h_{fg} \dot{V}(\omega_i - \omega_o) \\ &= \rho_o h_{fg} (\text{ACH})(V_{\text{building}})(\omega_i - \omega_o)\end{aligned}\quad (16-43)$$

where h_{fg} is the latent heat of vaporization at the indoor temperature (about 2340 kJ/kg) and $\omega_i - \omega_o$ is the humidity ratio difference between the indoor and outdoor air, which can be determined from the psychrometric charts. The latent heat load is particularly significant in summer months in hot and humid regions such as Florida and coastal Texas. In winter, the humidity ratio of outdoor air is usually much lower than that of indoor air, and the latent infiltration load in this case represents the energy needed to vaporize the required amount of water to raise the humidity of indoor air to the desired level.

Preventing Infiltration

Infiltration accounts for a significant part of the total heat loss, and sealing the sites of air leaks by *caulking* or *weather-stripping* should be the first step to reduce energy waste and heating and cooling costs. Weatherizing requires some work, of course, but it is relatively easy and inexpensive to do.

Caulking can be applied with a caulking gun inside and outside where two stationary surfaces such as a wall and a window frame meet. It is easy to apply and is very effective in fixing air leaks. Potential sites of air leaks that can be fixed by caulking are entrance points of electrical wires, plumbing, and telephone lines; the sill plates where walls meet the foundation; joints between exterior window frames and siding; joints between door frames and walls; and around exhaust fans.

Weather-stripping is a narrow piece of metal, vinyl, rubber, felt, or foam that seals the contact area between the fixed and movable sections of a joint. Weather-stripping is best suited for sites that involve moving parts such as doors and windows. It minimizes air leakage by closing off the gaps between the moving parts and their fixed frames when they are closed. All exterior doors and windows should be weatherized. There are various kinds of weather-stripping, and some kinds are more suitable for particular kinds of gaps. Some common types of weather-stripping are shown in Fig. 16-61.

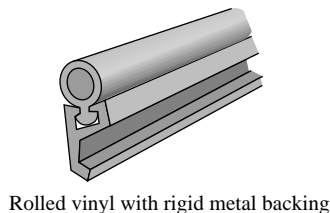

Rolled vinyl with rigid metal backing

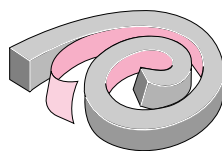

Nonreinforced, self-adhesive

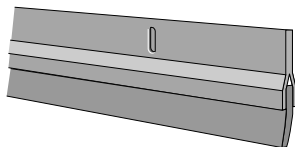

Door sweep
(vinyl lip with metal, wood, or plastic retainer)

FIGURE 16-61

Some common types of weather-stripping.

EXAMPLE 16-16 Reducing Infiltration Losses by Winterizing

The average atmospheric pressure in Denver, Colorado (elevation = 1610 m), is 83.4 kPa, and the average winter temperature is 3.3°C. The pressurization test of a 2.7-m-high, 230 m² older home revealed that the seasonal average infiltration rate of the house is 1.8 ACH (Fig. 16-62). It is suggested that the infiltration rate of the house can be reduced by one-third to 1.2 ACH by winterizing the doors and the windows. If the house is heated by natural gas whose unit cost is \$0.58/therm (1 therm = 105,500 kJ) and the heating season can be taken to be six months, determine how much the home owner will save from the heating costs per year by this winterization project. Assume the house is maintained at 21°C at all times and the efficiency of the furnace is 0.75. Also, the latent heat load during the heating season in Denver is negligible.

SOLUTION A winterizing project will reduce the infiltration rate of a house from 1.8 ACH to 1.2 ACH. The resulting cost savings are to be determined.

Assumptions 1 The house is maintained at 21°C at all times. 2 The latent heat load during the heating season is negligible. 3 The infiltrating air is heated to 21°C before exfiltrates.

Properties The specific heat of air at room temperature is 1.007 kJ/kg · °C (Table A-15). The gas constant of air is 0.287 kJ/kg · K (Table A-16).

Analysis The density of air at the outdoor conditions is

$$\rho_o = \frac{P_o}{RT_o} = \frac{83.4 \text{ kPa}}{(0.287 \text{ kPa} \cdot \text{m}^3/\text{kg} \cdot \text{K})(276.3 \text{ K})} = 1.05 \text{ kg/m}^3$$

The volume of the building is

$$V_{\text{building}} = (\text{Floor area})(\text{Height}) = (230 \text{ m}^2)(2.7 \text{ m}) = 621 \text{ m}^3$$

The sensible infiltration heat load corresponding to the reduction in the infiltration rate of 0.6 ACH is

$$\begin{aligned} \dot{Q}_{\text{infiltration, saved}} &= \rho_o c_p (\text{ACH}_{\text{saved}})(V_{\text{building}})(T_i - T_o) \\ &= (1.05 \text{ kg/m}^3)(1.007 \text{ kJ/kg} \cdot \text{°C})(0.6/\text{h})(621 \text{ m}^3) \\ &\quad (21 - 3.3)\text{°C} \\ &= 6973 \text{ kJ/h} = 0.066 \text{ therm/h} \end{aligned}$$

since 1 therm = 105,500 kJ. The number of hours during a six-month period is $6 \times 30 \times 24 = 4320$ h. Noting that the furnace efficiency is 0.75 and the unit cost of natural gas is \$0.58/therm, the energy and money saved during the six-month period are

$$\begin{aligned} \text{Energy savings} &= (\dot{Q}_{\text{infiltration, saved}})(\text{No. of hours per year})/\text{Efficiency} \\ &= (0.066 \text{ therm/h})(4320 \text{ h/year})/0.75 \\ &= 380 \text{ therms/year} \end{aligned}$$

$$\begin{aligned} \text{Cost savings} &= (\text{Energy savings})(\text{Unit cost of energy}) \\ &= (380 \text{ therm/year})(\$0.58/\text{term}) \\ &= \mathbf{\$220/\text{year}} \end{aligned}$$

Therefore, reducing the infiltration rate by one-third will reduce the heating costs of this home owner by \$220 per year.

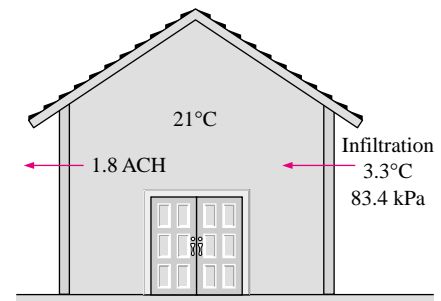

FIGURE 16-62
Schematic for Example 16-16.

16-11 ■ ANNUAL ENERGY CONSUMPTION

In the thermal analysis of buildings, two quantities of major interest are (1) the *size* or *capacity* of the heating and the cooling system and (2) the *annual energy consumption*. The size of a heating or cooling system is based on the *most demanding* situations under the anticipated *worst weather* conditions, whereas the average annual energy consumption is based on *average usage* situations under *average weather* conditions. Therefore, the calculation procedure of annual energy usage is quite different than that of design heating or cooling loads.

16-64
HEATING AND COOLING OF BUILDINGS

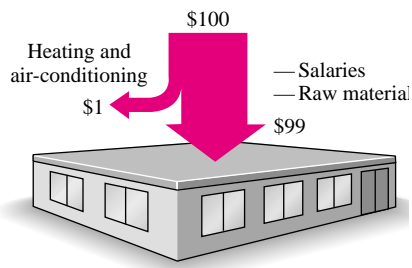
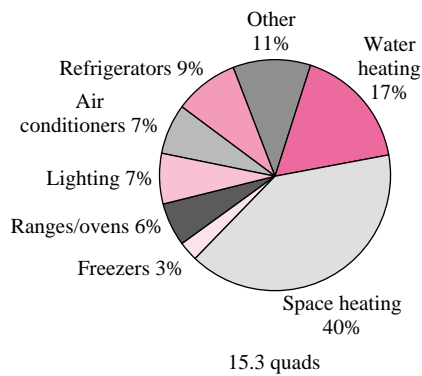
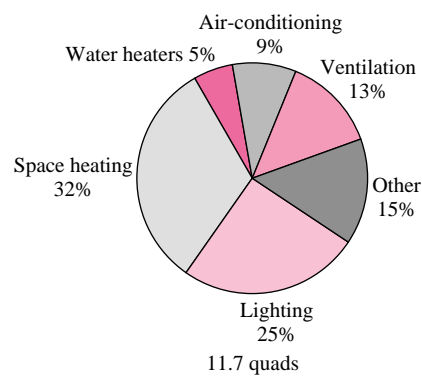

FIGURE 16-63
The heating and cooling cost of a commercial building constitutes about 1 percent of the total cost. Therefore, thermal comfort and thus productivity should not be risked to conserve energy.



(a) Residential buildings



(b) Commercial buildings

FIGURE 16-64
Breakdown of energy consumption in residential and commercial buildings in 1986.

(From U.S. Department of Energy.)

An analysis of annual energy consumption and cost usually accompanies the design heat load calculations and plays an important role in the selection of a heating or cooling system. Often a choice must be made among several systems that have the same capacity but different efficiencies and initial costs. More efficient systems usually consume less energy and money per year, but they cost more to purchase and install. The purchase of a more efficient but more expensive heating or cooling system can be economically justified only if the system saves more in the long run from energy costs than its initial cost differential.

The impact on the *environment* may also be an important consideration on the selection process: A system that consumes less fuel pollutes the environment less, and thus reduces all the adverse effects associated with environmental pollution. But it is difficult to quantify the environmental impact in an economic analysis unless a price is put on it.

One way of reducing the initial and operating costs of a heating or cooling system is to compromise the *thermal comfort* of occupants. This option should be avoided, however, since a small loss in employee productivity due to thermal discomfort can easily offset any potential gains from reduced energy use. The U.S. Department of Energy periodically conducts comprehensive energy surveys to determine the energy usage in residential as well as nonresidential buildings and the industrial sector. Two 1983 reports (DOE/EIA-0246 and DOE/EIA-0318) indicate that the national average natural gas usage of all commercial buildings in the United States is $800,000 \text{ kJ/m}^2 \cdot \text{year}$, which is worth about $\$5/\text{m}^2$ per year. The reports also indicate that the average annual electricity consumption of commercial buildings due to air-conditioning is about $130 \text{ kWh/m}^2 \cdot \text{year}$, which is worth about $\$10/\text{m}^2$ per year. Therefore, the average cost of heating and cooling of commercial buildings is about $\$15/\text{m}^2$ per year. This corresponds to $\$300/\text{year}$ for a 20 m^2 floor space, which is large enough for an average office worker. But noting that the average salary and benefits of a worker are no less than $\$30,000$ a year, it appears that the heating and cooling cost of a commercial building constitutes about 1 percent of the total cost (Fig. 16-63). Therefore, even a 1 percent loss in productivity due to thermal discomfort may cost the business owner more than the entire cost of energy. Likewise, the loss of business in retail stores due to unpleasant thermal conditions will cost the store owner many times what he or she is saving from energy. Thus, the message to the HVAC engineer is clear: *in the design of heating and cooling systems of commercial buildings, treat the thermal comfort conditions as design constraints rather than as variables. The cost of energy is a very small fraction of the goods and services produced, and thus, do not incorporate any energy conservation measures that may result in a loss of productivity or loss of revenues.*

When trying to minimize annual energy consumption, it is helpful to have a general idea about where most energy is used. A *breakdown* of energy usage in residential and commercial buildings is given in Fig. 16-64. Note that space heating accounts for most energy usage in all buildings, followed by water heating in residential buildings and lighting in commercial buildings. Therefore, any conservation measure dealing with them will have the greatest impact.

For *existing buildings*, the amount and cost of energy (fuel or electricity) used for heating and cooling of a building can be determined by simply

analyzing the *utility bills* for a typical year. For example, if a house uses natural gas for space and water heating, the natural gas consumption for space heating can be determined by estimating the average monthly usage for water heating from summer bills, multiplying it by 12 to estimate the yearly usage, and subtracting it from the total annual natural gas usage. Likewise, the annual electricity usage and cost for air-conditioning can be determined by simply evaluating the excess electricity usage during the cooling months and adding them up. If the bills examined are not for a typical year, corrections can be made by comparing the weather data for that year to the average weather data.

For buildings that are at the design or construction stage, the evaluation of annual energy consumption involves the determination of (1) the *space load* for heating or cooling due to heat transfer through the building envelope and infiltration, (2) the *efficiency* of the furnace where the fuel is burned or the COP of cooling or heat pump systems, and (3) the *parasitic energy* consumed by the distribution system (pumps or fans) and the energy lost or gained from the pipes or ducts (Fig. 16–65). The determination of the space load is similar to the determination of the peak load, except the average conditions are used for the weather instead of design conditions. The space heat load is usually based on the average temperature difference between the indoors and the outdoors, but internal heat gains and solar effects must also be considered for better accuracy. Very accurate results can be obtained by using hourly data for a whole year and by making a computer simulation using one of the commercial building energy analysis software packages.

The simplest and most intuitive way of estimating the annual energy consumption of a building is the **degree-day** (or **degree-hour**) **method**, which is a *steady-state* approach. It is based on constant indoor conditions during the heating or cooling season and assumes the efficiency of the heating or cooling equipment is not affected by the variation of outdoor temperature. These conditions will be closely approximated if all the thermostats in a building are set at the same temperature at the beginning of a heating or cooling season and are never changed, and a seasonal average efficiency is used (rather than the full-load or design efficiency) for the furnaces or coolers.

You may think that anytime the outdoor temperature T_o drops below the indoor temperature T_i at which the thermostat is set, the heater will turn on to make up for the heat losses to the outside. However, the internal heat generated by people, lights, and appliances in occupied buildings as well as the heat gain from the sun during the day, \dot{Q}_{gain} , will be sufficient to compensate for the heat losses from the building until the outdoor temperature drops below a certain value. The *outdoor temperature* above which no heating is required is called the **balance point temperature** T_{balance} (or the *base temperature*) and is determined from (Fig. 16–66)

$$K_{\text{overall}}(T_i - T_{\text{balance}}) = \dot{Q}_{\text{gain}} \rightarrow T_{\text{balance}} = T_i - \frac{\dot{Q}_{\text{gain}}}{K_{\text{overall}}} \quad (16-44)$$

where K_{overall} is the *overall heat transfer coefficient* of the building in $\text{W}/^\circ\text{C}$. There is considerable uncertainty associated with the determination of the balance point temperature, but based on the observations of typical buildings, it is usually taken to be 18°C in Europe and 65°F (18.3°C) in the

16-65
CHAPTER 16

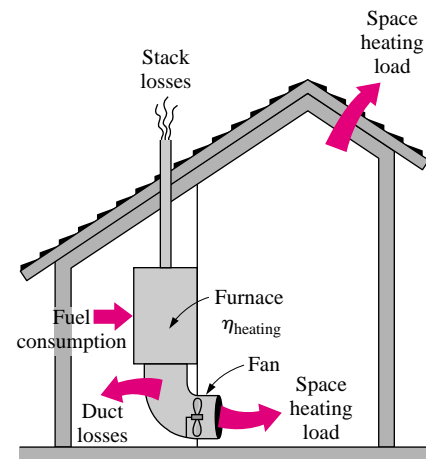

FIGURE 16–65

The various quantities involved in the evaluation of the annual energy consumption of a building.

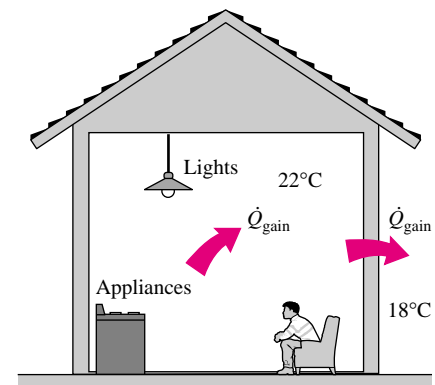
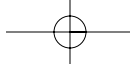

FIGURE 16–66

The heater of a building will not turn on as long as the internal heat gain makes up for the heat loss from a building (the *balance point* outdoor temperature).



United States for convenience. The rate of energy consumption of the heating system is

$$\dot{Q}_{\text{heating}} = \frac{K_{\text{overall}}}{\eta_{\text{heating}}} (T_{\text{balance}} - T_o)^+ \quad (16-45)$$

where η_{heating} is the efficiency of the heating system, which is equal to 1.0 for electric resistance heating systems, COP for the heat pumps, and combustion efficiency (about 0.6 to 0.95) for furnaces. If K_{overall} , T_{balance} , and η_{heating} , are taken to be constants, the annual energy consumption for heating can be determined by integration (or by summation over daily or hourly averages) as

$$Q_{\text{heating, year}} = \frac{K_{\text{overall}}}{\eta_{\text{heating}}} \int [T_{\text{balance}} - T_o(t)]^+ dt \cong \frac{K_{\text{overall}}}{\eta_{\text{heating}}} DD_{\text{heating}} \quad (16-46)$$

where DD_{heating} is the **heating degree-days**. The + sign above the parenthesis indicates that only positive values are to be counted, and the temperature difference is to be taken to be zero when $T_o > T_{\text{balance}}$. The number of degree-days for a heating season is determined from

$$DD_{\text{heating}} = (1 \text{ day}) \sum_{\text{days}} (T_{\text{balance}} - T_{o,\text{avg,day}})^+ \text{ (}^\circ\text{C-day)} \quad (16-47)$$

where $T_{o,\text{avg,day}}$ is the *average* outdoor temperature for each day (without considering temperatures above T_{balance}), and the summation is performed daily (Fig. 16-67). Similarly, we can also define *heating degree-hours* by using hourly average outdoor temperatures and performing the summation hourly. Note that the number of degree-hours is equal to 24 times the number of degree-days. Heating degree-days for each month and the yearly total for a balance point temperature of 65°F (18.3°C) are given in Table 16-5 for several cities. *Cooling degree-days* are defined in the same manner to evaluate the annual energy consumption for cooling, using the same balance point temperature.

Expressing the design energy consumption of a building for heating as $\dot{Q}_{\text{design}} = K_{\text{overall}}(T_i - T_o)_{\text{design}}/\eta_{\text{heating}}$ and comparing it to the annual energy consumption gives the following relation between energy consumption at designed conditions and the annual energy consumption (Table 16-22),

$$\frac{\dot{Q}_{\text{heating, year}}}{\dot{Q}_{\text{design}}} = \frac{DD_{\text{heating}}}{(T_i - T_o)_{\text{design}}} \quad (16-48)$$

where $(T_i - T_o)_{\text{design}}$ is the design indoor–outdoor temperature difference.

Despite its simplicity, remarkably accurate results can be obtained with the *degree-day method* for most houses and single-zone buildings using a hand calculator. Besides, the degree-days characterize the *severity* of the weather at a location accurately, and the degree-day method serves as a valuable tool for gaining an *intuitive understanding* of annual energy consumption. But when the efficiency of the HVAC equipment changes considerably with the outdoor temperature, or the balance-point temperature varies significantly with time, it may be necessary to consider several bands (or “bins”) of outdoor temperatures and to determine the energy consumption for each band using the equipment efficiency for those outdoor temperatures and the number of hours those

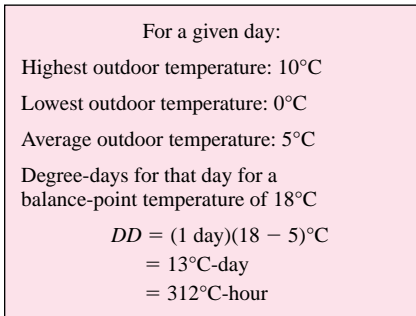

FIGURE 16-67

The outdoor temperatures for a day during which the heating degree-day is 13°C-day.

TABLE 16-22

The ratio of annual energy consumption to the hourly energy consumption at design conditions at several locations for $T_i = 21^\circ\text{C}$ (from Eq. 16-48).

City	$T_{o, \text{design}}$	$^\circ\text{C-days}$	Ratio
Tucson	0°C	1000	1142
Las Vegas	-2.2°C	1505	1557
Charleston	-11.7°C	2487	1825
Cleveland	-15°C	3528	2352
Minneapolis	-24.4°C	4657	2462
Anchorage	-27.8°C	6036	2969

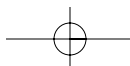

temperatures are in effect. Then the annual energy consumption is obtained by adding the results of all bands. This modified degree-day approach is known as the **bin method**, and the calculations can still be performed using a hand calculator.

The steady-state methods become too crude and unreliable for buildings that experience large daily fluctuations, such as a typical, well-lit, crowded office building that is open Monday through Friday from 8 AM to 5 PM. This is especially the case when the building is equipped with programmable thermostats that utilize night setback to conserve energy. Also, the efficiency of a heat pump varies considerably with the outdoor temperatures, and the efficiencies of boilers and chillers are lower at part load. Further, the internal heat gain and necessary ventilation rate of commercial buildings vary greatly with occupancy. In such cases, it may be necessary to use a *dynamic method* such as the **transfer function method** to predict the annual energy consumption accurately. Such dynamic methods are based on performing *hourly calculations* for the entire year and adding the results. Obviously they require the use of a computer with a well-developed and hopefully user-friendly program. Very accurate results can be obtained with dynamic methods since they consider the hourly variation of indoor and outdoor conditions as well as the solar radiation, the thermal inertia of the building, the variation of the heat loss coefficient of the building, and the variation of equipment efficiency with outdoor temperatures. Even when a dynamic method is used to determine the annual energy consumption, the simple degree-day method can still be used as a check to ensure that the results obtained are in the proper range.

Some simple practices can result in significant *energy savings* in residential buildings while causing minimal discomfort. The annual energy consumption can be reduced by up to 50 percent by setting the thermostat back in winter and up in summer, and setting it back further at nights (Table 16-23). Reducing the thermostat setting in winter by 2.2°C alone can save 12 to 18 percent; setting the thermostat back by 5.6°C alone for 8 h on winter nights can save 7 to 13 percent. Setting the thermostat up in summer by 2.2°C can reduce the energy consumption of residential cooling units by 18 to 32 percent. Cooling energy consumption can be reduced by up to 25 percent by suncreening and by up to 9 percent by attic ventilation (ASHRAE *Handbook of Fundamentals*, p. 28.14).

TABLE 16-23

Approximate percent savings from thermostat setback from 18°C for 14 hours per night and the entire weekends (from National Frozen Food Association/U.S. Department of Energy, "Reducing Energy Costs Means a Better Bottom Line")

°C-days	Amount of setback, °C			
	2.8°C	5.6°C	8.4°C	11.2°C
556	13%	25%	38%	50%
1111	12	24	36	48
1667	11	22	33	44
2222	10	20	30	40
2778	9	19	28	38
3333	8	16	24	32
3889	7	15	22	30
4444	7	13	19	26
5000	6	11	16	22
5556	5	9	14	18

EXAMPLE 16-17 Energy and Money Savings by Winterization

You probably noticed that the heating bills are highest in December and January because the temperatures are the lowest in those months. Imagine that you have moved to Cleveland, Ohio, and your roommate offered to pay the remaining heating bills if you pay the December and January bills only. Should you accept this offer?

SOLUTION It makes sense to accept this offer if the cost of heating in December and January is less than half of the heating bill for the entire winter. The energy consumption of a building for heating is proportional to the heating degree-days. For Cleveland, they are listed in Table 16-5 to be 1088°F-day (604°C-day) for December, 1159°F-day (644°C-day) for January, and 6351°F-day

TABLE 16-24

Monthly heating degree-days for Cleveland, Ohio, and the yearly total (Example 16-17).

Month	Degree-days	
	°F-days	°C-days
July	9	5
August	25	14
September	105	58
October	384	213
November	738	410
December	1088	604
January	1159	644
February	1047	582
March	918	510
April	552	307
May	260	144
June	66	37
Yearly total	6351	3528

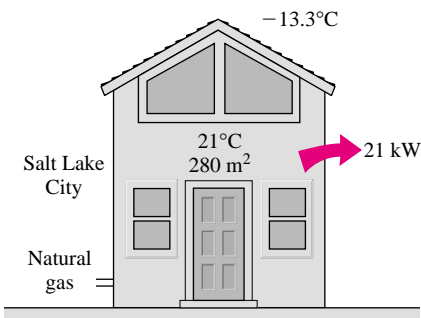

FIGURE 16-68
Schematic for Example 16-18.

(3528°C-day) for the entire year (Table 16-24). The ratio of December–January degree-days to the annual degree-days is

$$\frac{DD_{\text{heating, Dec-Jan}}}{DD_{\text{heating, annual}}} = \frac{(604 + 644)^{\circ\text{C-day}}}{3528^{\circ\text{C-day}}} = 0.354$$

which is less than half. Therefore, this is a good offer and **should be accepted**.

EXAMPLE 16-18 Annual Heating Cost of a House

Using indoor and outdoor winter design temperatures of 21°C and –13.3°C, respectively, the design heat load of a 280-m² house in Salt Lake City, Utah, is determined to be 21 kW (Fig. 16-68). The house is to be heated by natural gas that is to be burned in an 80 percent efficient furnace. If the unit cost of natural gas is \$0.55/therm (1 therm = 105,500 kJ), estimate the annual gas consumption of this house and its cost.

SOLUTION The annual gas consumption and its cost for a house in Salt Lake City with a design heat load of 21 kW are to be determined.

Assumption The house is maintained at 21°C at all times during the heating season.

Analysis The rate of gas consumption of the house for heating at design conditions is

$$\begin{aligned}\dot{Q}_{\text{design}} &= \dot{Q}_{\text{design, load}} / \eta_{\text{heating}} \\ &= (21 \text{ kW}) / 0.80 = 26.25 \text{ kW} = 0.896 \text{ therm/h}\end{aligned}$$

The annual heating degree-days of Salt Lake City are listed in Table 16-5 to be 6052°F-day (3362°C-day). Then the annual natural gas usage of the house can be determined from Equation 16-48 to be

$$\begin{aligned}\dot{Q}_{\text{heating, year}} &= \frac{DD_{\text{heating}}}{(T_i - T_o)_{\text{design}}} \dot{Q}_{\text{design}} \\ &= \frac{3362^{\circ\text{C-day}}}{[21 - (-13.3)]^{\circ\text{C}}} \left(\frac{24 \text{ h}}{1 \text{ day}} \right) (0.896 \text{ therm/h}) = \mathbf{2108 \text{ therms/year}}\end{aligned}$$

whose cost is

$$\begin{aligned}\text{Annual heating cost} &= (\text{Annual energy consumption})(\text{Unit cost of energy}) \\ &= (2108 \text{ therms/year})(\$0.55/\text{therm}) = \mathbf{\$1159/\text{year}}\end{aligned}$$

Therefore, it will cost \$1159 per year to heat this house.

EXAMPLE 16-19 Choosing the Most Economical Air Conditioner

Consider a house whose annual air-conditioning load is estimated to be 40,000 kWh in an area where the unit cost of electricity is \$0.09/kWh. Two air conditioners are considered for the house. Air conditioner A has a seasonal average COP of 2.5 and costs \$2500 to purchase and install. Air conditioner B

has a seasonal average COP of 5.0 and costs \$4000 to purchase and install. If all else is equal, determine which air conditioner is a better buy (Fig. 16-69).

SOLUTION A decision is to be made between a cheaper but inefficient and an expensive but efficient air conditioner for a house.

Assumption The two air conditioners are comparable in all aspects other than the initial cost and the efficiency.

Analysis The unit that will cost less during its lifetime is a better buy. The total cost of a system during its lifetime (the initial, operation, maintenance, etc.) can be determined by performing a life cycle cost analysis. A simpler alternative is to determine the simple payback period. The energy and cost savings of the more efficient air conditioner in this case are

$$\begin{aligned}\text{Energy savings} &= (\text{Annual energy usage of A}) - (\text{Annual energy usage of B}) \\ &= (\text{Annual cooling load})(1/\text{COP}_A - 1/\text{COP}_B) \\ &= (40,000 \text{ kWh/year})(1/2.5 - 1/5.0) \\ &= 8000 \text{ kWh/year}\end{aligned}$$

$$\begin{aligned}\text{Cost savings} &= (\text{Energy savings})(\text{Unit cost of energy}) \\ &= (8000 \text{ kWh/year})(\$0.09/\text{kWh}) = \mathbf{\$720/\text{year}}\end{aligned}$$

Therefore, the more efficient air conditioner will pay for the \$1500 cost differential in this case in about two years. A cost-conscious consumer will have no difficulty in deciding that the more expensive but more efficient air conditioner B is clearly a better buy in this case since air conditioners last at least 15 years. But the decision would not be so easy if the unit cost of electricity at that location was \$0.03/kWh instead of \$0.09/kWh, or if the annual air-conditioning load of the house was just 10,000 kWh instead of 40,000 kWh.

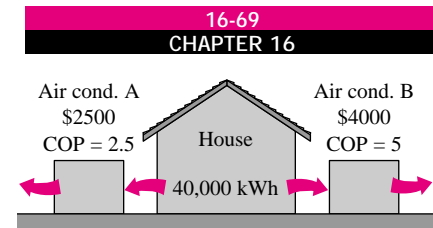

FIGURE 16-69

Schematic for Example 16-19.

SUMMARY

In a broad sense, *air-conditioning* means to condition the air to the desired level by heating, cooling, humidifying, dehumidifying, cleaning, and deodorizing. The purpose of the air-conditioning system of a building is to provide complete thermal comfort for its occupants. The metabolic heat generated in the body is dissipated to the environment through the skin and lungs by convection and radiation as *sensible heat* and by evaporation as *latent heat*. The total *sensible heat loss* can be expressed by combining convection and radiation heat losses as

$$\begin{aligned}\dot{Q}_{\text{conv} + \text{rad}} &= (h_{\text{conv}} + h_{\text{rad}})A_{\text{clothing}}(T_{\text{clothing}} - T_{\text{operative}}) \\ &= \frac{A_{\text{clothing}}(T_{\text{skin}} - T_{\text{clothing}})}{R_{\text{clothing}}}\end{aligned}$$

where R_{clothing} is the *unit thermal resistance of clothing*, which involves the combined effects of conduction, convection, and radiation between the skin and the outer surface of clothing. The *operative temperature* $T_{\text{operative}}$ is approximately the arithmetic average of the ambient and surrounding surface

temperatures. Another environmental index used in thermal comfort analysis is the *effective temperature*, which combines the effects of temperature and humidity.

The desirable ranges of temperatures, humidities, and ventilation rates for indoors constitute the typical *indoor design conditions*. The set of extreme outdoor conditions under which a heating or cooling system must be able to maintain a building at the indoor design conditions is called the *outdoor design conditions*. The *heating or cooling loads* of a building represent the heat that must be supplied to or removed from the interior of a building to maintain it at the desired conditions. The effect of solar heating on opaque surfaces is accounted for by replacing the ambient temperature in the heat transfer relation through the walls and the roof by the *sol-air temperature*, which is defined as the equivalent outdoor air temperature that gives the same rate of heat flow to a surface as would the combination of incident solar radiation, convection with the ambient air, and radiation exchange with the sky and the surrounding surfaces.

Heat flow into an exterior surface of a building subjected to solar radiation can be expressed as

$$\dot{Q}_{\text{surface}} = h_o A_s (T_{\text{sol-air}} - T_{\text{surface}})$$

where

$$T_{\text{sol-air}} = T_{\text{ambient}} + \frac{\alpha_s \dot{q}_{\text{solar}}}{h_o} - \frac{\varepsilon \sigma (T_{\text{ambient}}^4 - T_{\text{surr}}^4)}{h_o}$$

and α_s is the *solar absorptivity* and ε is the *emissivity* of the surface, h_o is the combined convection and radiation heat transfer coefficient, and \dot{q}_{solar} is the solar radiation incident on the surface.

The conversion of chemical or electrical energy to thermal energy in a building constitutes the *internal heat gain* of a building. The primary sources of internal heat gain are people, lights, appliances, and miscellaneous equipment such as computers, printers, and copiers. The average amount of heat given off by a person depends on the level of activity and can range from about 100 W for a resting person to more than 500 W for a physically very active person. The heat gain due to a motor inside a conditioned space can be expressed as

$$\dot{Q}_{\text{motor, total}} = \dot{W}_{\text{motor}} \times f_{\text{load}} \times f_{\text{usage}} / \eta_{\text{motor}}$$

where \dot{W}_{motor} is the power rating of the motor, f_{load} is the *load factor* of the motor during operation, f_{usage} is the *usage factor*, and η_{motor} is the *motor efficiency*.

Under steady conditions, the rate of heat transfer through any section of a *building wall* or *roof* can be determined from

$$\dot{Q} = UA_s(T_i - T_o) = \frac{A_s(T_i - T_o)}{R}$$

where T_i and T_o are the indoor and outdoor air temperatures, A_s is the heat transfer area, U is the overall heat transfer coefficient (the *U-factor*), and $R = 1/U$ is the overall unit thermal resistance (the *R-value*). The overall *R-value* of a wall or roof can be determined from the thermal resistances of the individual components using the thermal resistance network. The *effective emissivity* of a plane-parallel air space is given by

$$\frac{1}{\varepsilon_{\text{effective}}} = \frac{1}{\varepsilon_1} + \frac{1}{\varepsilon_2} - 1$$

where ε_1 and ε_2 are the emissivities of the surfaces of the air space.

Heat losses through the below-grade section of a *basement wall* and through the *basement floor* are given as

$$\dot{Q}_{\text{basement walls}} = U_{\text{wall, ave}} A_{\text{wall}} (T_{\text{basement}} - T_{\text{ground surface}})$$

$$\dot{Q}_{\text{basement floor}} = U_{\text{floor}} A_{\text{floor}} (T_{\text{basement}} - T_{\text{ground surface}})$$

where $U_{\text{wall, ave}}$ is the average overall heat transfer coefficient between the basement wall and the surface of the ground and U_{floor} is the overall heat transfer coefficient at the basement

floor. Heat loss from floors that sit directly on the ground at or slightly above the ground level is mostly through the perimeter to the outside air rather than through the floor into the ground and is expressed as

$$\dot{Q}_{\text{floor on grade}} = U_{\text{grade}} p_{\text{floor}} (T_{\text{indoor}} - T_{\text{outdoor}})$$

where U_{grade} represents the rate of heat transfer from the slab per unit temperature difference between the indoor temperature T_{indoor} and the outdoor temperature T_{outdoor} and per unit length of the perimeter p_{floor} of the building. When the crawl space temperature is known, heat loss through the *floor of the building* is determined from

$$\dot{Q}_{\text{building floor}} = U_{\text{building floor}} A_{\text{floor}} (T_{\text{indoor}} - T_{\text{crawl}})$$

where $U_{\text{building floor}}$ is the overall heat transfer coefficient for the floor.

Windows are considered in three regions when analyzing heat transfer through them: (1) the *center-of-glass*, (2) the *edge-of-glass*, and (3) the *frame* regions. Total rate of heat transfer through the window is determined by adding the heat transfer through each region as

$$\begin{aligned} \dot{Q}_{\text{window}} &= \dot{Q}_{\text{center}} + \dot{Q}_{\text{edge}} + \dot{Q}_{\text{frame}} \\ &= U_{\text{window}} A_{\text{window}} (T_{\text{indoors}} - T_{\text{outdoors}}) \end{aligned}$$

where

$$U_{\text{window}} = (U_{\text{center}} A_{\text{center}} + U_{\text{edge}} A_{\text{edge}} + U_{\text{frame}} A_{\text{frame}}) / A_{\text{window}}$$

is the *U-factor* or the *overall heat transfer coefficient* of the window; A_{window} is the window area; A_{center} , A_{edge} , and A_{frame} are the areas of the center, edge, and frame sections of the window, respectively; and U_{center} , U_{edge} , and U_{frame} are the heat transfer coefficients for the center, edge, and frame sections of the window.

The sum of the transmitted solar radiation and the portion of the absorbed radiation that flows indoors constitutes the *solar heat gain* of the building. The fraction of incident solar radiation that enters through the glazing is called the *solar heat gain coefficient* SHGC, and the total solar heat gain through that window is determined from

$$\dot{Q}_{\text{solar, gain}} = \text{SHGC} \times A_{\text{glazing}} \times \dot{q}_{\text{solar, incident}}$$

where A_{glazing} is the glazing area of the window and $\dot{q}_{\text{solar, incident}}$ is the solar heat flux incident on the outer surface of the window. Using the standard 3-mm-thick double-strength clear window glass sheet whose SHGC is 0.87 as the reference glazing, the *shading coefficient* SC is defined as

$$\begin{aligned} \text{SC} &= \frac{\text{Solar heat gain of product}}{\text{Solar heat gain of reference glazing}} \\ &= \frac{\text{SHGC}}{\text{SHGC}_{\text{ref}}} = \frac{\text{SHGC}}{0.87} = 1.15 \times \text{SHGC} \end{aligned}$$

Shading devices are classified as *internal shading* and *external shading*, depending on whether the shading device is placed inside or outside.

The uncontrolled entry of outside air into a building through unintentional openings is called *infiltration*, and it wastes a significant amount of energy since the air entering must be heated in winter and cooled in summer. The *sensible* and *latent heat load* of infiltration are expressed as

$$\begin{aligned}\dot{Q}_{\text{infiltration,sensible}} &= \rho_o c_p \dot{V}(T_i - T_o) = \rho_o c_p (\text{ACH}) \\ &\quad \times (V_{\text{building}})(T_i - T_o) \\ \dot{Q}_{\text{infiltration,latent}} &= \rho_o h_{fg} \dot{V}(\omega_i - \omega_o) = \rho_o h_{fg} (\text{ACH}) \\ &\quad \times (V_{\text{building}})(\omega_i - \omega_o)\end{aligned}$$

where ρ_o is the density of outdoor air; c_p is the specific heat of air (about 1 kJ/kg · °C); $\dot{V} = (\text{ACH}) \times (V_{\text{building}})$ is the volumetric flow rate of air, which is the number of air changes per hour times the volume of the building; and $T_i - T_o$ is the temperature difference between the indoor and outdoor air. Also, h_{fg} is the la-

tent heat of vaporization at indoor temperature (about 2340 kJ/kg) and $\omega_i - \omega_o$ is the humidity ratio difference between the indoor and outdoor air.

The *annual energy consumption* of a building depends on the space load for heating or cooling, the efficiency of the heating or cooling equipment, and the parasitic energy consumed by the pumps or fans and the energy lost or gained from the pipes or ducts. The annual energy consumption of a building can be estimated using the *degree-day method* as

$$Q_{\text{heating,year}} = \frac{K_{\text{overall}}}{\eta_{\text{heating}}} DD_{\text{heating}}$$

where DD_{heating} is the *heating degree-days*, K_{overall} is the overall heat transfer coefficient of the building in W/°C or Btu/h · °F, and η_{heating} is the efficiency of the heating system, which is equal to 1.0 for electric resistance heating systems, COP for the heat pumps, and combustion efficiency (about 0.6 to 0.95) for furnaces.

REFERENCES AND SUGGESTED READING

1. American Society of Heating, Refrigeration, and Air-Conditioning Engineers. *Handbook of Fundamentals*. Atlanta: ASHRAE, 1993.
2. *How to Reduce Your Energy Costs*. 2nd ed. Boston: Center for Information Sharing, Inc. (through Sierra Pacific Power Company), 1991.
3. J. F. Kreider and A. Rabl. *Heating and Cooling of Buildings*. New York: McGraw-Hill, 1994.
4. F. C. McQuiston and J. D. Parker. *Heating, Ventilating, and Air Conditioning*. 4th ed. New York: Wiley, 1994.
5. *Radiant Barrier Attic Fact Sheet*. DOE/CE-0335P. Washington, DC: U.S. Department of Energy, 1991.
6. "Replacement Windows." *Consumer Reports*, Yonkers, NY: Consumer Union. October 1993, p. 664.
7. H. J. Sauer, Jr., and R. H. Howell. *Principles of Heating, Ventilating, and Air Conditioning*. Atlanta: ASHRAE, 1994.
8. W. F. Stoecker and J. W. Jones. *Refrigeration and Air Conditioning*. New York: McGraw-Hill, 1982.

PROBLEMS*

A Brief History

16-1C In 1775, Dr. William Cullen made ice in Scotland by evacuating the air in a water tank. Explain how that device works, and discuss how the process can be made more efficient.

16-2C When was the first ammonia-absorption refrigeration system developed? Who developed the formulas related to dry-bulb, wet-bulb, and dew-point temperatures, and when?

16-3C When was the concept of heat pump conceived and by whom? When was the first heat pump built, and when were the heat pumps mass produced?

*Problems designated by a "C" are concept questions, and students are encouraged to answer them all.

Human Body and Thermal Comfort

16-4C What is metabolism? What is the range of metabolic rate for an average man? Why are we interested in metabolic rate of the occupants of a building when we deal with heating and air conditioning?

16-5C Why is the metabolic rate of women, in general, lower than that of men? What is the effect of clothing on the environmental temperature that feels comfortable?

16-6C What is asymmetric thermal radiation? How does it cause thermal discomfort in the occupants of a room?

16-7C How do (a) draft and (b) cold floor surfaces cause discomfort for a room's occupants?

16-8C What is stratification? Is it likely to occur at places with low or high ceilings? How does it cause thermal discomfort for a room's occupants? How can stratification be prevented?

16-9C Why is it necessary to ventilate buildings? What is the effect of ventilation on energy consumption for heating in winter and for cooling in summer? Is it a good idea to keep the bathroom fans on all the time? Explain.

Heat Transfer from the Human Body

16-10C Consider a person who is resting or doing light work. Is it fair to say that roughly one-third of the metabolic heat generated in the body is dissipated to the environment by convection, one-third by evaporation, and the remaining one-third by radiation?

16-11C What is sensible heat? How is the sensible heat loss from a human body affected by (a) skin temperature, (b) environment temperature, and (c) air motion?

16-12C What is latent heat? How is the latent heat loss from the human body affected by (a) skin wettedness and (b) relative humidity of the environment? How is the rate of evaporation from the body related to the rate of latent heat loss?

16-13C How is the insulating effect of clothing expressed? How does clothing affect heat loss from the body by convection, radiation, and evaporation? How does clothing affect heat gain from the sun?

16-14C Explain all the different mechanisms of heat transfer from the human body (a) through the skin and (b) through the lungs.

16-15C What is operative temperature? How is it related to the mean ambient and radiant temperatures? How does it differ from effective temperature?

16-16 The convection heat transfer coefficient for a clothed person while walking in still air at a velocity of 0.5 to 2 m/s is given by $h = 8.6V^{0.53}$ where V is in m/s and h is in $\text{W/m}^2 \cdot ^\circ\text{C}$. Plot the convection coefficient against the walking velocity, and compare the convection coefficients in that range to the average radiation coefficient of about $5 \text{ W/m}^2 \cdot ^\circ\text{C}$.

16-17 A clothed or unclothed person feels comfortable when the skin temperature is about 33°C . Consider an average man wearing summer clothes whose thermal resistance is 1.1 clo. The man feels very comfortable while standing in a room maintained at 20°C . If this man were to stand in that room unclothed, determine the temperature at which the room must be maintained for him to feel thermally comfortable. Assume the latent heat loss from the person to remain the same.

Answer: 27.8°C

16-18 An average (1.82 kg or 4.0 lbm) chicken has a basal metabolic rate of 5.47 W and an average metabolic rate of 10.2 W (3.78 W sensible and 6.42 W latent) during normal activity. If there are 100 chickens in a breeding room, determine the rate of total heat generation and the rate of moisture production in the room. Take the heat of vaporization of water to be 2430 kJ/kg.

16-19 Consider a large classroom with 90 students on a hot summer day. All the lights with 2.0 kW of rated power are kept on. The room has no external walls, and thus heat gain through the walls and the roof is negligible. Chilled air is available at 15°C , and the temperature of the return air is not to exceed 25°C . The average rate of metabolic heat generation by a person sitting or doing light work is 115 W (70 W sensible and 45 W latent). Determine the required flow rate of air in kg/s, that needs to be supplied to the room. *Answer: 0.83 kg/s*

16-20 A smoking lounge is to accommodate 15 heavy smokers. Determine the minimum required flow rate of fresh air that needs to be supplied to the lounge. *Answer: $0.45 \text{ m}^3/\text{s}$*

16-21 A person feels very comfortable in his house in light clothing when the thermostat is set at 22°C and the mean radiation temperature (the average temperature of the surrounding surfaces) is also 22°C . During a cold day, the average mean radiation temperature drops to 18°C . To what value must the

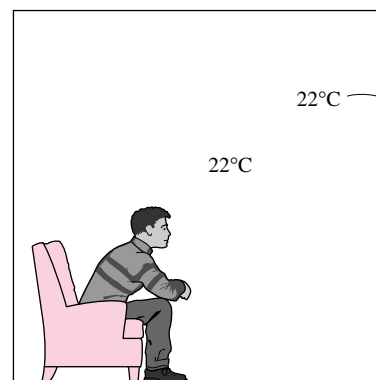

FIGURE P16-21

indoor air temperature be raised to maintain the same level of comfort in the same clothing?

16-22 A car mechanic is working in a shop whose interior space is not heated. Comfort for the mechanic is provided by two radiant heaters that radiate heat at a total rate of 4 kJ/s. About 5 percent of this heat strikes the mechanic directly. The shop and its surfaces can be assumed to be at the ambient temperature, and the emissivity and absorptivity of the mechanic can be taken to be 0.95 and the surface area to be 1.8 m². The mechanic is generating heat at a rate of 350 W, half of which is latent, and is wearing medium clothing with a thermal resistance of 0.7 clo. Determine the lowest ambient temperature in which the mechanic can work comfortably.

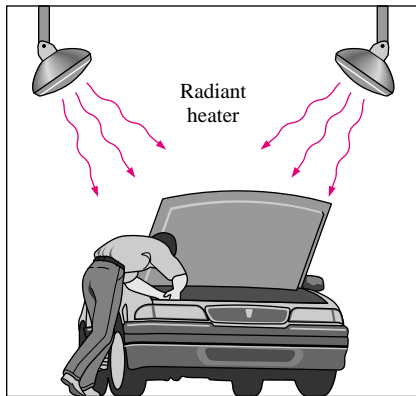

FIGURE P16-22

Design Conditions for Heating and Cooling

16-23C What is winter outdoor design temperature? How does it differ from average winter outdoor temperature? How do 97.5 percent and 99 percent winter outdoor design temperatures differ from each other?

16-24C Weather data for two different cities A and B are compared. Is it possible for city A to have a lower winter design temperature but a higher average winter temperature? Explain.

16-25C What is the effect of solar radiation on (a) the design heating load in winter and (b) the annual energy consumption for heating? Answer the same question for the heat generated by people, lights, and appliances.

16-26C What is the effect of solar radiation on (a) the design cooling load in summer and (b) the annual energy consumption for cooling? Answer the same question for the heat generated by people, lights, and appliances.

16-27C Does the moisture level of the outdoor air affect the cooling load in summer, or can it just be ignored? Explain. Answer the same question for the heating load in winter.

16-28C The recommended design heat transfer coefficients for combined convection and radiation on the outer surface of a building are 34 W/m² · °C for winter and 22.7 W/m² · °C for summer. What is the reason for different values?

16-29C What is sol-air temperature? What is it used for? What is the effect of solar absorptivity of the outer surface of a wall on the sol-air temperature?

16-30C Consider the solar energy absorbed by the walls of a brick house. Will most of this energy absorbed by the wall be transferred to indoors or lost to the outdoors? Why?

16-31 Determine the outdoor design conditions for Lincoln, Nebraska, for summer for the 2.5 percent level and for winter for the 97.5 percent level.

16-32 Specify the indoor and outdoor design conditions for a hospital in Wichita, Kansas.

16-33 The south masonry wall of a house is made of 10-cm-thick red face brick, 10-cm-thick common brick, 19-mm-thick air space, and 13-mm-thick gypsum board, and its overall heat transfer coefficient is 1.6 W/m² · °C, which includes the effects of convection on both sides. The house is located at 40°N latitude, and its cooling system is to be sized on the basis of the heat gain at 3 PM solar time on July 21. The interior of the house is to be maintained at 22°C, and the area of the wall is 20 m². If the design ambient air temperature at that time is 35°C, determine (a) the design heat gain through the wall, (b) the fraction of this heat gain due to solar heating, and (c) the fraction of incident solar radiation transferred into the house through the wall.

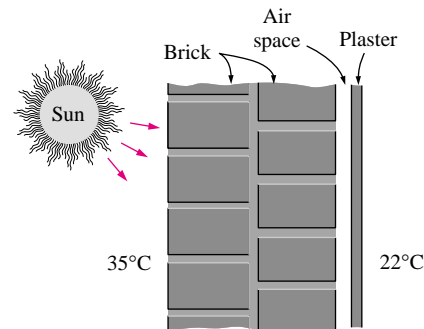

FIGURE P16-33

16-34 The west wall of a shopping center in Pittsburgh, Pennsylvania (40°N latitude), is 45 m long and 3.7 m high. The 2.5 percent summer design temperature of Pittsburgh is 30°C, and the interior of the building is maintained at 22°C. The wall is made of face brick and concrete block with cement mortar in between, reflective air space, and a gypsum wallboard. The overall heat transfer coefficient of the wall is 0.80 W/m² · °C, which includes the effects of convection on both sides. The cooling system is to be sized on the basis of the heat gain at 16:00 hour (4 PM) solar time in late July. Determine (a) the design heat gain through the wall and (b) the fraction of this heat gain due to solar heating.

16-35 The roof of a building in Istanbul, Turkey (40°N latitude), is made of a 30-cm-thick horizontal layer of concrete, painted white to minimize solar gain, with a layer of plaster inside. The overall heat transfer coefficient of the roof is 1.8 W/m² · °C, which includes the effects of convection on both

the interior and exterior surfaces. The cooling system is to be sized on the basis of the heat gain at 16:00 hour solar time in late July. The interior of the building is to be maintained at 22°C, and the summer design temperature of Istanbul is 30°C. If the exposed surface area of the roof is 150 m², determine (a) the design heat gain through the roof and (b) the fraction of this heat gain due to solar heating.

Answers: (a) 4320 W, (b) 50 percent

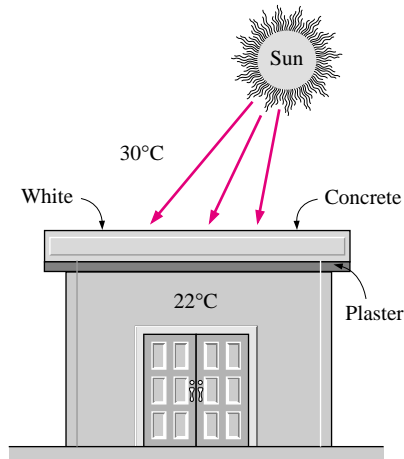

FIGURE P16-35

Heat Gain from People, Lights, and Appliances

16-36C Is the heat given off by people in a concert hall an important consideration in the sizing of the air-conditioning system for that building or can it be ignored? Explain.

16-37C During a lighting retrofitting project, all the incandescent lamps of a building are replaced by high-efficiency fluorescent lamps. Explain how this retrofit will affect the (a) design cooling load, (b) annual energy consumption for cooling, and (c) annual energy consumption for heating for the building.

16-38C Give two good reasons why it is usually a good idea to replace incandescent light bulbs by compact fluorescent bulbs that may cost 40 times as much to purchase.

16-39C Explain how the motors and appliances in a building affect the (a) design cooling load, (b) annual energy consumption for cooling, and (c) annual energy consumption for heating of the building.

16-40C Define motor efficiency, and explain how it affects the design cooling load of a building and the annual energy consumption for cooling.

16-41C Consider a hooded range in a kitchen with a powerful fan that exhausts all the air heated and humidified by the range. Does the heat generated by this range still need to be considered in the determination of the cooling load of the kitchen or can it just be ignored since all the heated air is exhausted?

16-42 Consider a 3-kW hooded electric open burner in an area where the unit costs of electricity and natural gas are \$0.09/kWh and \$1.10/therm (1 therm = 29.3 kWh), respec-

tively. The efficiency of open burners can be taken to be 73 percent for electric burners and 38 percent for gas burners. Determine the amount of the electrical energy used directly for cooking, the cost of energy per “utilized” kWh, and the contribution of this burner to the design cooling load. Repeat the calculations for the gas burner.

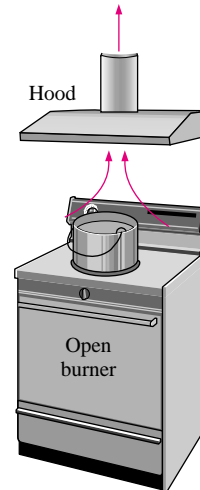

FIGURE P16-42

16-43 An exercise room has eight weight-lifting machines that have no motors and four treadmills each equipped with a 2.5-hp motor. The motors operate at an average load factor of 0.7, at which their efficiency is 0.77. During peak evening hours, all 12 pieces of exercising equipment are used continuously, and there are also two people doing light exercises while waiting in line for one piece of the equipment. Determine the rate of heat gain of the exercise room from people and the equipment at peak load conditions. How much of this heat gain is in the latent form?

16-44 A 75-hp motor with an efficiency of 91.0 percent is worn out and is replaced by a high-efficiency motor having an efficiency of 95.4 percent. Determine the reduction in the rate of internal heat gain due to higher efficiency under full-load conditions. *Answer: 2836 W*

16-45 The efficiencies of commercial hot plates are 48 and 23 percent for electric and gas models, respectively. For the same amount of “utilized” energy, determine the ratio of internal heat generated by gas hot plates to that by electric ones.

16-46 Consider a classroom for 40 students and one instructor. Lighting is provided by 18 fluorescent light bulbs, 40 W each, and the ballasts consume an additional 10 percent. Determine the rate of internal heat generation in this classroom when it is fully occupied. *Answer: 5507 W*

16-47 A 60-hp electric car is powered by an electric motor mounted in the engine compartment. If the motor has an average efficiency of 88 percent, determine the rate of heat supply by the motor to the engine compartment at full load.

16-48 A room is cooled by circulating chilled water through a heat exchanger located in a room. The air is circulated

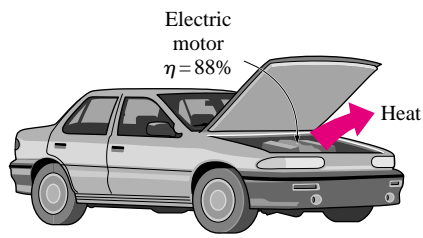

FIGURE P16-47

through the heat exchanger by a 0.25-hp fan. Typical efficiency of small electric motors driving 0.25-hp equipment is 54 percent. Determine the contribution of the fan-motor assembly to the cooling load of the room. *Answer: 345 W*

16-49 Consider an office room that is being cooled adequately by a 12,000 Btu/h window air conditioner. Now it is decided to convert this room into a computer room by installing several computers, terminals, and printers with a total rated power of 3.5 kW. The facility has several 4000 Btu/h air conditioners in storage that can be installed to meet the additional cooling requirements. Assuming a usage factor of 0.4 (i.e., only 40 percent of the rated power will be consumed at any given time) and additional occupancy of four people, determine how many of these air conditioners need to be installed in the room.

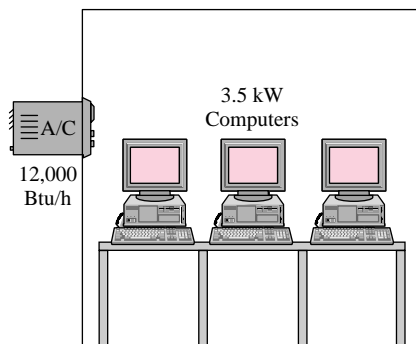

FIGURE P16-49

16-50 A restaurant purchases a new 8-kW electric range for its kitchen. Determine the increase in the design cooling load of the kitchen if the range is (a) hooded and (b) unhooded.

Answers: (a) 4.0 kW, (b) 1.28 kW

16-51 A department store expects to have 80 customers and 15 employees at peak times in summer. Determine the contribution of people to the sensible, latent, and total cooling load of the store.

16-52 In a movie theater in winter, 500 people are watching a movie. The heat losses through the walls, windows, and the roof are estimated to be 44,000 W. Determine if the theater needs to be heated or cooled.

Heat Transfer through the Walls and Roofs

16-53C What is the R -value of a wall? How does it differ from the unit thermal resistance of the wall? How is it related to the U -factor?

16-54C What is effective emissivity for a plane-parallel air space? How is it determined? How is radiation heat transfer through the air space determined when the effective emissivity is known?

16-55C The unit thermal resistances (R -values) of both 40-mm and 90-mm vertical air spaces are given in Table 16-13 to be $0.22 \text{ m}^2 \cdot ^\circ\text{C}/\text{W}$, which implies that more than doubling the thickness of air space in a wall has no effect on heat transfer through the wall. Do you think this is a typing error? Explain.

16-56C What is a radiant barrier? What kind of materials are suitable for use as radiant barriers? Is it worthwhile to use radiant barriers in the attics of homes?

16-57C Consider a house whose attic space is ventilated effectively so that the air temperature in the attic is the same as the ambient air temperature at all times. Will the roof still have any effect on heat transfer through the ceiling? Explain.

16-58 Determine the summer R -value and the U -factor of a wood frame wall that is built around 38-mm \times 140-mm wood studs with a center-to-center distance of 400 mm. The 140-mm-wide cavity between the studs is filled with mineral fiber batt insulation. The inside is finished with 13-mm gypsum wall-board and the outside with 13-mm wood fiberboard and 13-mm \times 200-mm wood bevel lapped siding. The insulated cavity constitutes 80 percent of the heat transmission area, while the studs, headers, plates, and sills constitute 20 percent.

Answers: $3.213 \text{ m}^2 \cdot ^\circ\text{C}/\text{W}$, $0.311 \text{ W}/\text{m}^2 \cdot ^\circ\text{C}$

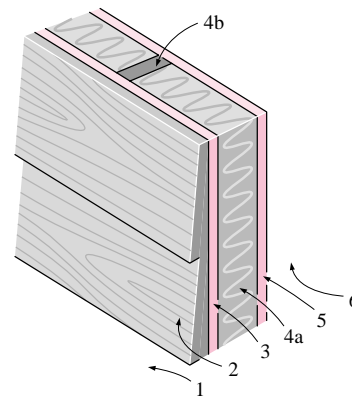

FIGURE P16-58

16-59 The 13-mm-thick wood fiberboard sheathing of the wood stud wall in Prob. 16-59 is replaced by a 25-mm-thick rigid foam insulation. Determine the percent increase in the R -value of the wall as a result.

16-76

HEATING AND COOLING OF BUILDINGS

16-60 Consider a flat ceiling that is built around 38-mm \times 90-mm wood studs with a center-to-center distance of 400 mm. The lower part of the ceiling is finished with 13-mm gypsum wallboard, while the upper part consists of a wood subfloor ($R = 0.166 \text{ m}^2 \cdot ^\circ\text{C}/\text{W}$), a 16-mm plywood, a layer of felt ($R = 0.011 \text{ m}^2 \cdot ^\circ\text{C}/\text{W}$), and linoleum ($R = 0.009 \text{ m}^2 \cdot ^\circ\text{C}/\text{W}$). Both sides of the ceiling are exposed to still air. The air space constitutes 82 percent of the heat transmission area, while the studs and headers constitute 18 percent. Determine the winter R -value and the U -factor of the ceiling assuming the 90-mm-wide air space between the studs (a) does not have any reflective surface, (b) has a reflective surface with $\varepsilon = 0.05$ on one side, and (c) has reflective surfaces with $\varepsilon = 0.05$ on both sides. Assume a mean temperature of 10°C and a temperature difference of 5.6°C for the air space.

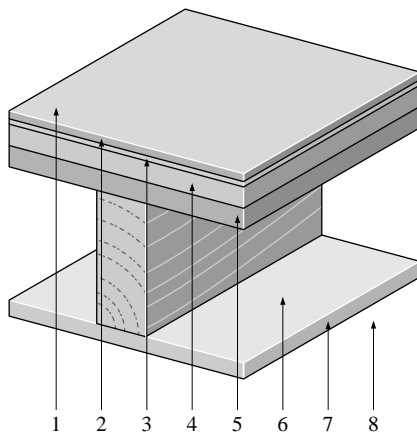

FIGURE P16-60

16-61 Determine the winter R -value and the U -factor of a masonry cavity wall that consists of 100-mm common bricks, a 90-mm air space, 100-mm concrete blocks made of lightweight aggregate, 20-mm air space, and 13-mm gypsum wallboard separated from the concrete block by 20-mm-thick (1-in. \times 3-in. nominal) vertical furring whose center-to-center distance is 400 mm. Neither side of the two air spaces is coated with any reflective films. When determining the R -value of the

air spaces, the temperature difference across them can be taken to be 16.7°C with a mean air temperature of 10°C . The air space constitutes 84 percent of the heat transmission area, while the vertical furring and similar structures constitute 16 percent.

Answers: $1.02 \text{ m}^2 \cdot ^\circ\text{C}/\text{W}$, $0.978 \text{ W}/\text{m}^2 \cdot ^\circ\text{C}$

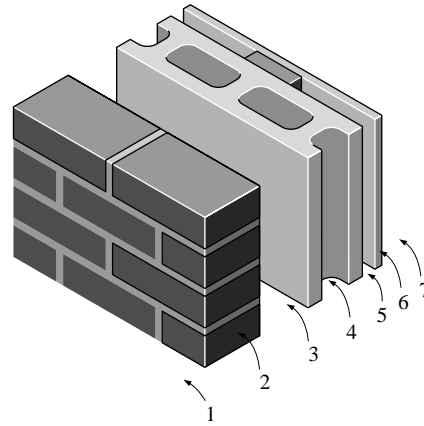

FIGURE P16-61

16-62 Repeat Prob. 16-61 assuming one side of both air spaces is coated with a reflective film of $\varepsilon = 0.05$.

16-63 Determine the winter R -value and the U -factor of a masonry wall that consists of the following layers: 100-mm face bricks, 100-mm common bricks, 25-mm urethane rigid foam insulation, and 13-mm gypsum wallboard.

Answers: $1.404 \text{ m}^2 \cdot ^\circ\text{C}/\text{W}$, $0.712 \text{ W}/\text{m}^2 \cdot ^\circ\text{C}$

16-64 The overall heat transfer coefficient (the U -value) of a wall under winter design conditions is $U = 1.40 \text{ W}/\text{m}^2 \cdot ^\circ\text{C}$. Determine the U -value of the wall under summer design conditions.

16-65 The overall heat transfer coefficient (the U -value) of a wall under winter design conditions is $U = 2.25 \text{ W}/\text{m}^2 \cdot ^\circ\text{C}$. Now a layer of 100-mm face brick is added to the outside, leaving a 20-mm air space between the wall and the bricks. Determine the new U -value of the wall. Also, determine the rate of heat transfer through a 3-m-high, 7-m-long section of

the wall after modification when the indoor and outdoor temperatures are 22°C and -5°C , respectively.

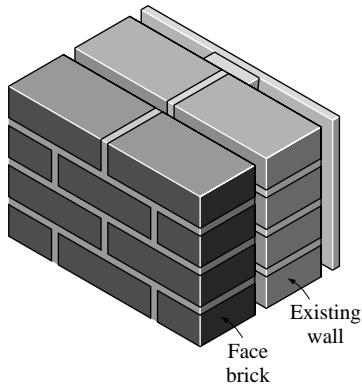

FIGURE P16-65

16-66 Determine the summer and winter R -values, in $\text{m}^2 \cdot ^{\circ}\text{C}/\text{W}$, of a masonry wall that consists of 100-mm face bricks, 13-mm of cement mortar, 100-mm lightweight concrete block, 40-mm air space and 20-mm plasterboard.

Answers: 0.809 and $0.795 \text{ m}^2 \cdot ^{\circ}\text{C}/\text{W}$

16-67 The overall heat transfer coefficient of a wall is determined to be $U = 0.420 \text{ W}/\text{m}^2 \cdot ^{\circ}\text{C}$ under the conditions of still air inside and winds of $12 \text{ km}/\text{h}$ outside. What will the U -factor be when the wind velocity outside is doubled?

Answer: $0.1422 \text{ W}/\text{m}^2 \cdot ^{\circ}\text{C}$

16-68 Two homes are identical, except that the walls of one house consist of 200-mm lightweight concrete blocks, 20-mm air space, and 20-mm plasterboard, while the walls of the other house involve the standard $R=2.4 \text{ m}^2 \cdot ^{\circ}\text{C}/\text{W}$ frame wall construction. Which house do you think is more energy efficient?

16-69 Determine the R -value of a ceiling that consists of a layer of 19-mm acoustical tiles whose top surface is covered with a highly reflective aluminum foil for winter conditions. Assume still air below and above the tiles.

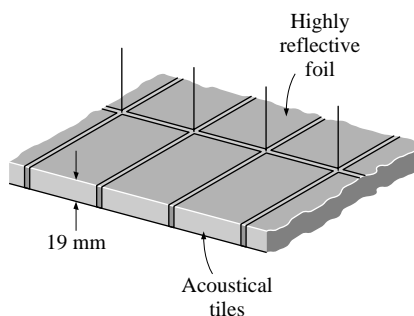

FIGURE P16-69

Heat Loss from Basement Walls and Floors

16-70C What is the mechanism of heat transfer from the basement walls and floors to the ground? What is the effect of the composition and moisture content of the soil on this heat transfer?

16-71C Consider a basement wall that is completely below grade. Will heat loss through the upper half of the wall be greater or smaller than the heat loss through the lower half? Why?

16-72C Does a building lose more heat to the ground through the floor of a basement or through the below-grade section of the basement wall per unit surface area? Explain.

16-73C Is heat transfer from a floor on grade at ground level proportional to the surface area or perimeter of the floor?

16-74C Crawl spaces are often vented to prevent moisture accumulation and associated problems. How does venting the crawl space affect heat loss through the floor?

16-75C Consider a house with an unheated crawl space in winter. If the vents of the crawl space are tightly closed, do you think the cold water pipes should still be insulated to avoid the danger of freezing?

16-76 Consider a basement in Anchorage, Alaska, where the mean winter temperature is -5.0°C . The basement floor is 7 m wide and 10 m long, and the basement floor is 1.8 m below the ground level. The top 0.9-m section of the wall below the grade is insulated with $R=2.20 \text{ m}^2 \cdot ^{\circ}\text{C}/\text{W}$ insulation. Assuming the interior temperature of the basement to be 20°C , determine the peak heat loss from the basement to the ground through its walls and floor.

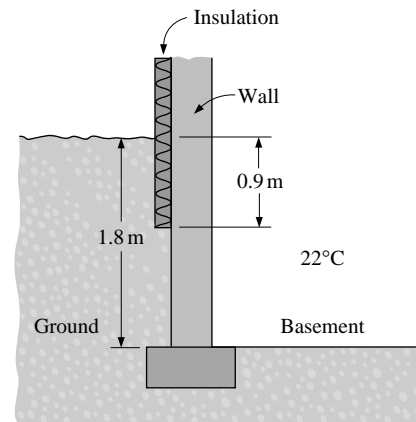

FIGURE P16-76

16-77 Consider a crawl space that is 10 m wide, 18 m long, and 0.80 m high whose vent is kept open. The interior of the house is maintained at 21°C and the ambient temperature is 2.5°C . Determine the rate of heat loss through the floor of the house to the crawl space for the cases of (a) insulated and (b) uninsulated floor. *Answers: (a) 1439 W , (b) 4729 W*

16-78 The dimensions of a house with basement in Boise, Idaho, are $18 \text{ m} \times 12 \text{ m}$. The 1.8-m -high portion of the basement wall is below the ground level and is not insulated. If the basement is maintained at 18°C , determine the rate of design heat loss from the basement through its walls and floor.

16-79 A house in Baltimore, Maryland, has a concrete slab floor that sits directly on the ground at grade level. The house is 18 m long and 15 m wide, and the weather in Baltimore can be considered to be moderate. The walls of the house are made of 20-cm block wall with brick and are insulated from the edge to the footer with $R=0.95 \text{ m}^2 \cdot ^\circ\text{C}/\text{W}$ insulation. If the house is maintained at 22°C , determine the heat loss from the floor at winter design conditions. *Answer: 1873 W.*

16-80 Repeat Prob. 16-79 assuming the below-grade section of the wall is not insulated.

16-81 The crawl space of a house is 12 m wide, 20 m long, and 0.70 m high. The vents of the crawl space are kept closed, but air still infiltrates at a rate of 1.2 ACH. The indoor and outdoor design temperatures are 22°C and -5°C , respectively, and the deep-down ground temperature is 10°C . Determine the heat loss from the house to the crawl space, and the crawl space temperature assuming the walls, floor, and ceiling of the crawl space are (a) insulated and (b) uninsulated.

Answers: (a) 1.3°C , (b) 11.7°C

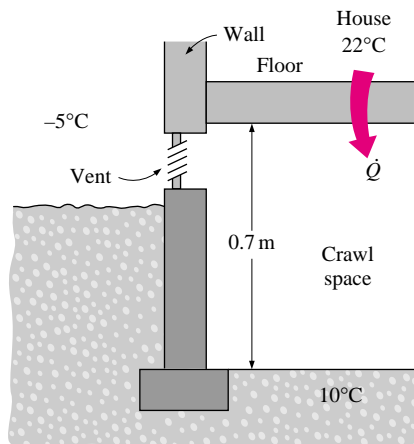

FIGURE P16-81

16-82 Repeat Prob. 16-81 assuming the vents are tightly sealed for winter and thus air infiltrations is negligible.

Heat Transfer through Windows

16-83C Why are the windows considered in three regions when analyzing heat transfer through them? Name those regions and explain how the overall U -value of the window is determined when the heat transfer coefficients for all three regions are known.

16-84C Consider three similar double-pane windows with air gap widths of 5, 10, and 20 mm. For which case will the heat transfer through the window will be a minimum?

16-85C In an ordinary double-pane window, about half of the heat transfer is by radiation. Describe a practical way of reducing the radiation component of heat transfer.

16-86C Consider a double-pane window whose air space width is 20 mm. Now a thin polyester film is used to divide the air space into two 10-mm-wide layers. How will the film affect (a) convection and (b) radiation heat transfer through the window?

16-87C Consider a double-pane window whose air space is flashed and filled with argon gas. How will replacing the air in the gap by argon affect (a) convection and (b) radiation heat transfer through the window?

16-88C Is the heat transfer rate through the glazing of a double-pane window higher at the center or edge section of the glass area? Explain.

16-89C How do the relative magnitudes of U -factors of windows with aluminum, wood, and vinyl frames compare? Assume the windows are identical except for the frames.

16-90 Determine the U -factor for the center-of-glass section of a double-pane window with a 13-mm air space for winter design conditions. The glazings are made of clear glass having an emissivity of 0.84. Take the average air space temperature at design conditions to be 10°C and the temperature difference across the air space to be 15°C .

16-91 A double-door wood-framed window with glass glazing and metal spacers is being considered for an opening that is

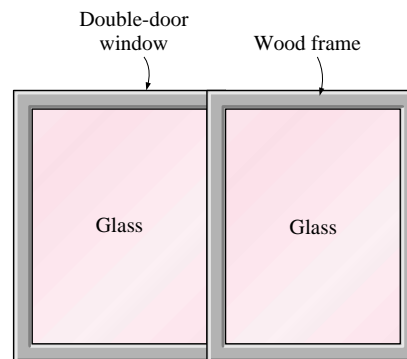

FIGURE P16-91

1.2 m high and 1.8 m wide in the wall of a house maintained at 20°C. Determine the rate of heat loss through the window and the inner surface temperature of the window glass facing the room when the outdoor air temperature is -8°C if the window is selected to be (a) 3-mm single glazing, (b) double glazing with an air space of 13 mm, and (c) low-e-coated triple glazing with an air space of 13 mm.

16-92 Determine the overall U -factor for a double-door-type, wood-framed, double-pane window with 13-mm air space and metal spacers, and compare your result to the value listed in Table 16-19. The overall dimensions of the window are 2.00 m \times 2.40 m, and the dimensions of each glazing are 1.92 m \times 1.14 m.

16-93 Consider a house in Atlanta, Georgia, that is maintained at 22°C and has a total of 14 m² of window area. The windows are double-door-type with wood frames and metal spacers. The glazing consists of two layers of glass with 12.7 mm of air space with one of the inner surfaces coated with reflective film. The winter average temperature of Atlanta is 11.3°C. Determine the average rate of heat loss through the windows in winter. *Answer: 319 W*

16-94 Consider an ordinary house with R -2.3 walls (walls that have an R -value of 2.3 m² \cdot °C/W). Compare this to the R -value of the common double-door windows that are double pane with 6.4 mm of air space and have aluminum frames. If the windows occupy only 20 percent of the wall area, determine if more heat is lost through the windows or through the remaining 80 percent of the wall area. Disregard infiltration losses.

16-95 The overall U -factor of a fixed wood-framed window with double glazing is given by the manufacturer to be $U = 2.76 \text{ W/m}^2 \cdot ^{\circ}\text{C}$ under the conditions of still air inside and winds of 12 km/h outside. What will the U -factor be when the wind velocity outside is doubled? *Answer: 2.88 W/m² \cdot °C*

16-96 The owner of an older house in Wichita, Kansas, is considering replacing the existing double-door type wood-framed, single-pane windows with vinyl-framed, double-pane windows with an air space of 6.4 mm. The new windows are of

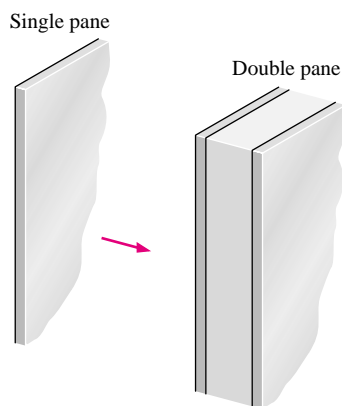

FIGURE P16-96

double-door type with metal spacers. The house is maintained at 22°C at all times, but heating is needed only when the outdoor temperature drops below 18°C because of the internal heat gain from people, lights, appliances, and the sun. The average winter temperature of Wichita is 7.1°C, and the house is heated by electric resistance heaters. If the unit cost of electricity is \$0.085/kWh and the total window area of the house is 17 m², determine how much money the new windows will save the home owner per month in winter.

Solar Heat Gain through Windows

16-97C What fraction of the solar energy is in the visible range (a) outside the earth's atmosphere and (b) at sea level on earth? Answer the same question for infrared radiation.

16-98C Describe the solar radiation properties of a window that is ideally suited for minimizing the air-conditioning load.

16-99C Define the SHGC (solar heat gain coefficient), and explain how it differs from the SC (shading coefficient). What are the values of the SHGC and SC of a single-pane, clear-glass window?

16-100C What does the SC (shading coefficient) of a device represent? How do the SCs of clear glass and heat-absorbing glass compare?

16-101C What is a shading device? Is an internal or external shading device more effective in reducing the solar heat gain through a window? How does the color of the surface of a shading device facing outside affect the solar heat gain?

16-102C What is the effect of a low-e coating on the inner surface of a window glass on the (a) heat loss in winter and (b) heat gain in summer through the window?

16-103C What is the effect of a reflective coating on the outer surface of a window glass on the (a) heat loss in winter and (b) heat gain in summer through the window?

16-104 A manufacturing facility located at 32°N latitude has a glazing area of 60 m² facing west that consists of double-pane windows made of clear glass (SHGC = 0.766). To reduce the solar heat gain in summer, a reflective film that will reduce the SHGC to 0.35 is considered. The cooling season consists of June, July, August, and September, and the heating season, October through April. The average daily solar heat fluxes incident on the west side at this latitude are 2.35, 3.03, 3.62, 4.00, 4.20, 4.24, 4.16, 3.93, 3.48, 2.94, 2.33, and 2.07 kWh/day \cdot m² for January through December, respectively. Also, the unit costs of electricity and natural gas are \$0.09/kWh and \$0.45/therm (1 therm = 29.31 kWh), respectively. If the coefficient of performance of the cooling system is 3.2 and the efficiency of the furnace is 0.90, determine the net annual cost savings due to installing reflective coating on the windows. Also, determine the simple payback period if the installation cost of reflective film is \$20/m². *Answers: \$76, 16 years*

16-80
HEATING AND COOLING OF BUILDINGS

16-105 A house located in Boulder, Colorado (40°N latitude), has ordinary double-pane windows with 6-mm-thick glasses and the total window areas are 8, 6, 6, and 4 m^2 on the south, west, east, and north walls. Determine the total solar heat gain of the house at 9:00, 12:00, and 15:00 solar time in July. Also, determine the total amount of solar heat gain per day for an average day in January.

16-106 Repeat Prob. 16-105 for double-pane windows that are gray-tinted.

16-107 Consider a building in New York (40°N latitude) that has 200 m^2 of window area on its south wall. The windows are double-pane, heat-absorbing type, and are equipped with light-colored venetian blinds with a shading coefficient of $\text{SC} = 0.30$. Determine the total solar heat gain of the building through the south windows at solar noon in April. What would your answer be if there were no blinds at the windows?

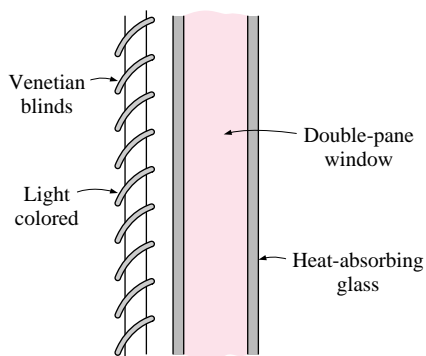

FIGURE P16-107

16-108 A typical winter day in Reno, Nevada (39°N latitude), is cold but sunny, and thus the solar heat gain through the windows can be more than the heat loss through them during daytime. Consider a house with double-door-type windows that are double paned with 3-mm-thick glasses and 6.4 mm of air space and have aluminum frames and spacers. The house is

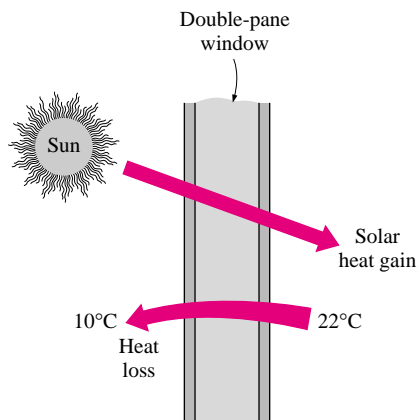

FIGURE P16-108

maintained at 22°C at all times. Determine if the house is losing more or less heat than it is gaining from the sun through an east window on a typical day in January for a 24-h period if the average outdoor temperature is 10°C . *Answer: less*

16-109 Repeat Prob. 16-108 for a south window.

16-110 Determine the rate of net heat gain (or loss) through a 2.7-m-high, 4.5-m-wide, fixed 3-mm single-glass window with aluminum frames on the west wall at 3 PM solar time during a typical day in January at a location near 40°N latitude when the indoor and outdoor temperatures are 21°C and -7°C , respectively. *Answer: 3632 W gain*

16-111 Consider a building located near 40°N latitude that has equal window areas on all four sides. The building owner is considering coating the south-facing windows with reflective film to reduce the solar heat gain and thus the cooling load. But someone suggests that the owner will reduce the cooling load even more if she coats the west-facing windows instead. What do you think?

Infiltration Heat Load and Weatherizing

16-112C What is infiltration? How does it differ from ventilation? How does infiltration affect the heating load in winter and the cooling load in summer? Explain.

16-113C Describe briefly two ways of measuring the infiltration rate of a building. Also, explain how the design infiltration rate differs from the seasonal average infiltration rate, and which is used when sizing a heating system.

16-114C How is the infiltration unit ACH (air changes per hour) defined? Why should too low and too high values of ACH be avoided?

16-115C How can the energy of the air vented out from the kitchens and bathrooms be saved?

16-116C Is latent heat load of infiltration necessarily zero when the relative humidity of the hot outside air in summer is the same as that of inside air? Explain.

16-117C Is latent heat load of infiltration necessarily zero when the humidity ratio (absolute humidity) of the hot outside air in summer is the same as that of inside air? Explain.

16-118C What are some practical ways of preventing infiltration in homes?

16-119C It is claimed that the infiltration rate and infiltration losses can be reduced by using radiant panel heaters since the air temperature can be lowered without sacrificing comfort. It is also claimed that radiant panels will increase the heat losses through the wall and the roof by conduction as a result of increased surface temperature. What do you think of these claims?

16-120 Consider two identical buildings, one in Los Angeles, California, where the atmospheric pressure is 101 kPa and the other in Denver, Colorado, where the atmospheric pressure is 83 kPa. Both buildings are maintained at 21°C, and the infiltration rate for both buildings is 1.2 ACH on a day when the outdoor temperature at both locations is 10°C. Disregarding latent heat, determine the ratio of the heat losses by infiltration at the two cities.

16-121 Determine the rate of sensible heat loss from a building due to infiltration if outdoor air at -10°C and 90 kPa enters the building at a rate of 35 L/s when the indoors is maintained at 22°C . *Answer: 1335 W*

16-122 The ventilating fan of the bathroom of a building has a volume flow rate of 30 L/s and runs continuously. The building is located in San Francisco, California, where the average

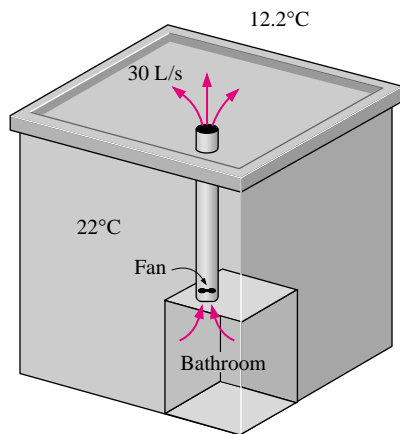

FIGURE P16-122

winter temperature is 12.2°C , and is maintained at 22°C at all times. The building is heated by electricity whose unit cost is $\$0.09/\text{kWh}$. Determine the amount and cost of the heat “vented out” per month in winter. *Answers: 256 kWh, \\$23.00*

16-123 For an infiltration rate of 1.2 ACH, determine the sensible, latent, and total infiltration heat load, in kW, of a building at sea level, that is 20 m long, 13 m wide, and 3 m high when the outdoor air is at 32°C and 50 percent relative humidity. The building is maintained at 24°C and 50 percent relative humidity at all times.

Annual Energy Consumption

16-124C Is it possible for a building in a city to have a higher peak heating load but a lower energy consumption for heating in winter than an identical building in another city? Explain.

16-125C Can we determine the annual energy consumption of a building for heating by simply multiplying the design heating load of the building by the number of hours in the heating season? Explain.

16-126C Considerable energy can be saved by lowering the thermostat setting in winter and raising it in summer by a few degrees. As the manager of a large commercial building, would you implement this measure to save energy and cut costs?

16-127C What is the number of heating degree-days for a winter day during which the average outdoor temperature was 10°C , and it never went above 18°C ?

16-128C What is the number of heating degree-days for a winter month during which the average outdoor temperature was 12°C , and it never went above 18°C ?

16-129C Someone claims that the $^{\circ}\text{C}$ -days for a location can be converted to $^{\circ}\text{F}$ -days by simply multiplying $^{\circ}\text{C}$ -days by 1.8. But another person insists that 32 must be added to the result because of the formula $T(^{\circ}\text{F}) = 1.8T(^{\circ}\text{C}) + 32$. Which person do you think is right?

16-130C What is balance-point temperature? Why is the balance-point temperature used in the determination of degree-days instead of the actual thermostat setting of a building?

16-131C Under what conditions is it proper to use the degree-day method to determine the annual energy consumption of a building? What is the number of heating degree-days for a day during which the average outdoor temperature was 10°C , and it never went above 18°C ?

16-132 Suppose you have moved to Syracuse, New York, in August, and your roommate, who is short of cash, offered to pay the heating bills during the upcoming year (starting January 1) if you pay the heating bills for the current calendar year until December 31. Is this a good offer for you?

16-133 Using indoor and outdoor winter design temperatures of 21°C and -23°C , respectively, the design heat load of a 230-m^2 house in Billings, Montana, is determined to be

24 kW. The house is to be heated by natural gas that will be burned in a 95 percent efficient, high-efficiency furnace. If the unit cost of natural gas is \$1.10/therm (1 therm = 105,500 kJ), estimate the annual gas consumption of this house and its cost.

Answers: 1841 therms, \$2025

16-134 Consider a building whose annual air-conditioning load is estimated to be 120,000 kWh in an area where the unit cost of electricity is \$0.10/kWh. Two air conditioners are considered for the building. Air conditioner A has a seasonal average COP of 3.2 and costs \$5500 to purchase and install. Air conditioner B has a seasonal average COP of 5.0 and costs \$7000 to purchase and install. If all else are equal, determine which air conditioner is a better buy.

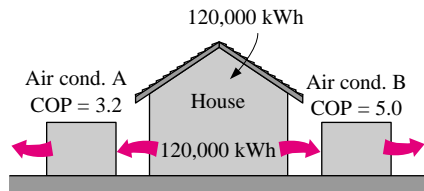

FIGURE P16-134

16-135 The lighting requirements of an industrial facility are being met by 700 40-W standard fluorescent lamps. The lamps are close to completing their service life, and are to be replaced by their 34-W high-efficiency counterparts that operate on the existing standard ballasts. The standard and high-efficiency fluorescent lamps can be purchased at quantity at a cost of \$1.77 and \$2.26 each, respectively. The facility operates 2800 hours a year and all of the lamps are kept on during operating hours. Taking the unit cost of electricity to be \$0.08/kWh and the ballast factor to be 1.1, determine how much energy and money will be saved a year as a result of switching to the high-efficiency fluorescent lamps. Also, determine the simple payback period. *Answers: 12,936 kWh, \$1035, 4 months*

16-136 The lighting needs of a storage room are being met by six fluorescent light fixtures, each fixture containing four

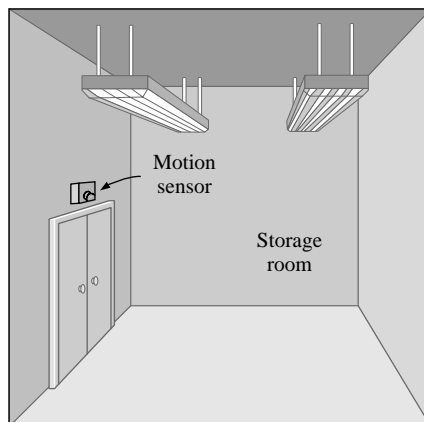

FIGURE P16-136

lamps rated at 60 W each. All the lamps are on during operating hours of the facility, which are 6 AM to 6 PM 365 days a year. The storage room is actually used for an average of three hours a day. If the price of the electricity is \$0.08/kWh, determine the amount of energy and money that will be saved as a result of installing a motion sensor. Also, determine the simple payback period if the purchase price of the sensor is \$32 and it takes 1 hour to install it at a cost of \$40.

16-137 An office building in the Reno, Nevada area (3346°C-days) is maintained at a temperature of 20°C at all times during the heating season, which is taken to be November 1 through April 30. The work hours of the office are 8 AM to 6 PM Monday through Friday, and there is no air-conditioning. An examination of the heating bills of the facility for the previous year reveals that the facility used 3530 therms of natural gas at an average price of \$1.15/therm, and thus paid \$4060 for heating. There are five thermostats in the facility to control the temperatures of various sections. The existing manual thermostats are to be replaced by programmable ones to reduce the heating costs. The new thermostats are to lower the temperature setting shortly before closing hour and raise it shortly before the opening hour. The thermostats will be set to 7.2°C during the off-work hours and to 20°C during the work hours. Determine the annual energy and cost savings as a result of installing five programmable thermostats. Also, determine the simple payback period if the installed cost of each programmable thermostat is \$325.

16-138 A 75-hp motor with an efficiency of 91.0 percent is worn out and is to be replaced with a high-efficiency motor having an efficiency of 95.4 percent. The machine operates 4368 hours a year at a load factor of 0.75. Taking the cost of electricity to be \$0.08/kWh, determine the amount of energy and money saved as a result of installing the high-efficiency motor instead of the standard one. Also, determine the simple payback period if the purchase prices of the standard and high-efficiency motors are \$5449 and \$5520, respectively.

Answers: 9290 kWh, \$743, 1.1 months

16-139 The steam requirements of a manufacturing facility are being met by a boiler of 3.8 million kJ/h input. The combustion efficiency of the boiler is measured to be 0.7 by a handheld flue gas analyzer. After tuning up the boiler, the combustion efficiency rises to 0.8. The boiler operates 1500 hours a year intermittently. Taking the unit cost of energy to be \$4.35 per million kJ, determine the annual energy and cost savings as a result of tuning up the boiler.

16-140 The space heating of a facility is accomplished by natural gas heaters that are 80 percent efficient. The compressed air needs of the facility are met by a large liquid-cooled compressor. The coolant of the compressor is cooled by air in a liquid-to-air heat exchanger whose air flow section is 1.0 m high and 1.0 m wide. During typical operation, the air is heated from 20°C to 52°C as it flows through the heat exchanger. The average velocity of air on the inlet side is measured to be 3 m/s.

The compressor operates 20 hours a day and 5 days a week throughout the year. Taking the heating season to be 6 months (26 weeks) and the cost of the natural gas to be \$1.00/therm (1 therm = 105,500 kJ), determine how much money will be saved by diverting the compressor waste heat into the facility during the heating season.

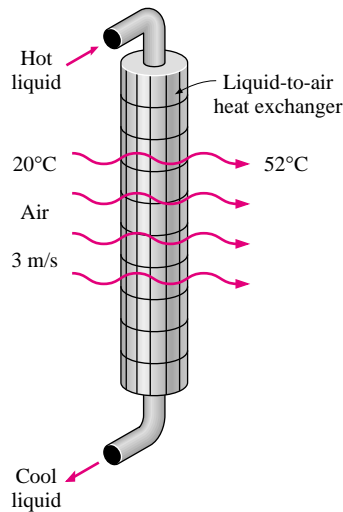

FIGURE P16-140

16-141 Consider a family in Atlanta, Georgia, whose average heating bill has been \$600 a year. The family now moves to an identical house in Denver, Colorado, where the fuel and electricity prices are also the same. How much do you expect the annual heating bill of this family to be in their new home?

16-142 The design heating load of a new house in Cleveland, Ohio, is calculated to be 19 kW for an indoor temperature of 22°C. If the house is to be heated by a natural gas furnace that is 90 percent efficient, predict the annual natural gas consumption of this house, in therms (1 therm = 105,500 kJ). Assume the entire house is maintained at indoor design conditions at all times.

16-143 For inside and outside design temperatures of 22°C and -12°C, respectively, a home located in Boise, Idaho, has a design heating load of 38 kW. The house is heated by electric resistance heaters, and the cost of electricity is \$0.06/kWh. Determine how much money the home owner will save if she lowers the thermostat from 22°C to 14°C from 11 PM to 7 AM every night in December.

Review Problems

16-144 Consider a home owner who is replacing his 20-year-old natural gas furnace that has an efficiency of 60 percent. The home owner is considering a conventional furnace that has an efficiency of 82 percent and costs \$1600, and a high-efficiency furnace that has an efficiency of 95 percent and costs \$2700. The home owner would like to buy the high-efficiency furnace

if the savings from the natural gas pay for the additional cost in less than eight years. If the home owner is presently paying \$1100 a year for heating, determine if he should buy the conventional or high-efficiency model.

16-145 The convection heat transfer coefficient for a clothed person seated in air moving at a velocity of 0.2 to 4 m/s is given by $h = 8.3V^{0.6}$ where V is in m/s and h is in $W/m^2 \cdot ^\circ C$. The convection coefficient at lower velocities is $3.1 W/m^2 \cdot ^\circ C$. Plot the convection coefficient against the air velocity, and compare the average convection coefficient to the average radiation coefficient of about $5 W/m^2 \cdot ^\circ C$.

16-146 Workers in a casting facility are surrounded with hot surfaces, with an average temperature of 40°C. The activity level of the workers corresponds to a heat generation rate of 300 W, half of which is latent. If the air temperature is 22°C, determine the velocity of air needed to provide comfort for the workers. Take the average exposed surface area and temperature of the workers to be 1.8 m² and 30°C, respectively.

16-147 Replacing incandescent lights by energy-efficient fluorescent lights can reduce the lighting energy consumption to one-fourth of what it was before. The energy consumed by the lamps is eventually converted to heat, and thus switching to energy-efficient lighting also reduces the cooling load in summer but increases the heating load in winter. Consider a building that is heated by a natural gas furnace having an efficiency of 80 percent and cooled by an air conditioner with a COP of 3.5. If electricity costs \$0.08/kWh and natural gas costs \$1.25/therm (1 therm = 29.31 kWh), and the annual heating load of the building is roughly equal to the annual cooling load, determine if efficient lighting will increase or decrease the total heating and cooling cost of the building. *Answer: Decrease*

16-148 A wall of a farmhouse is made of 200-mm common brick. Determine the rate of heat transfer through a 20-m² section of the wall when the indoor and outdoor temperatures are 20°C and -5°C, respectively, and the wall is exposed to 24 km/h winds. *Answer: 1280 W*

16-149 Determine the R -value and the overall heat transfer coefficient (the U -factor) of a 45° pitched roof that is built around nominal 2-in \times 4-in wood studs with a center-to-center distance of 600 mm. The 90-mm-wide air space between the studs has a reflective surface and its effective emissivity is 0.05. The lower part of the roof is finished with 13-mm gypsum wallboard and the upper part with 16-mm plywood, building

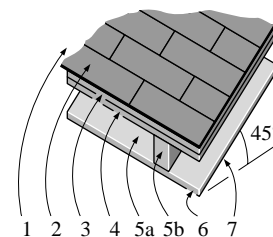

FIGURE P16-149

paper, and asphalt shingle roofing. The air space constitutes 80 percent of the heat transmission area, while the studs and headers constitute 20 percent.

16-150 The winter design heat load of a planned house is determined to be 32 kW. The original design involved aluminum-frame single-pane windows with a U -factor of $7.16 \text{ W/m}^2 \cdot ^\circ\text{C}$, and heat losses through the windows accounted for 26 percent of the total. Alarmed by the projected high cost of annual energy usage, the owner decided to switch to vinyl-frame double-pane windows whose U -factor is $2.74 \text{ W/m}^2 \cdot ^\circ\text{C}$. Determine the reduction in the heat load of the house as a result of switching to double-pane windows.

16-151 The attic of a 150-m^2 house in Thessaloniki, Greece (40°N latitude), is not vented in summer. The R -values of the roof and the ceiling are $1.4 \text{ m}^2 \cdot ^\circ\text{C/W}$ and $0.50 \text{ m}^2 \cdot ^\circ\text{C/W}$, respectively, and the ratio of the roof area to ceiling area is 1.30. The indoors are maintained at 23°C at all times. Determine the rate of heat gain through the roof in late July at 16:00 (4 PM) solar time if the outdoor temperature is 32°C , assuming the roof is (a) light colored and (b) dark colored.

Answers: (a) 1700 W, (b) 2900 W

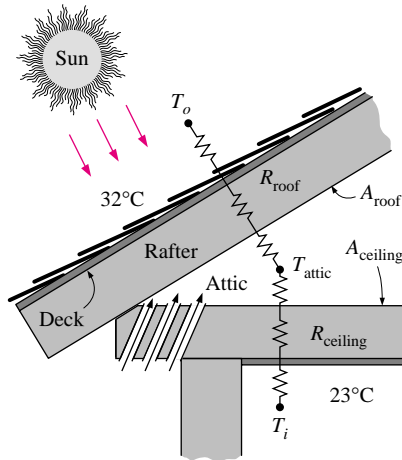

FIGURE P16-151

16-152 The dimensions of a house in Norfolk, Virginia, are $19 \text{ m} \times 10 \text{ m}$, and the house has a basement. The 1.8-m -high portion of the basement wall is below the ground level, and the top 0.6-m section of the wall below the grade is insulated with $R\text{-}0.73 \text{ m}^2 \cdot ^\circ\text{C/W}$ insulation. If the basement is maintained at 17°C , determine the rate of design heat loss from the basement through its walls and floor.

16-153 A house in Anchorage, Alaska, has a concrete slab floor that sits directly on the ground at grade level. The house is 20 m long and 15 m wide, and the weather in Alaska is very severe. The walls of the house are made of 20-cm block wall

with brick and are insulated from the edge to the footer with $R\text{-}0.95 \text{ m}^2 \cdot ^\circ\text{C/W}$ insulation. If the house is maintained at 22°C , determine the heat loss from the floor at winter design conditions.

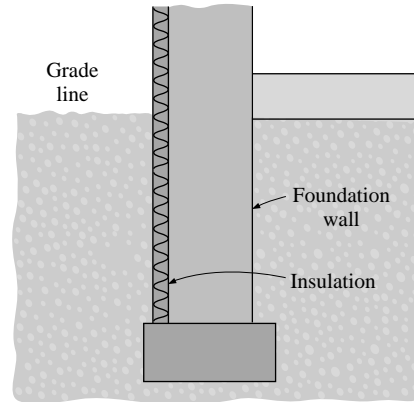

FIGURE P16-153

16-154 Repeat Prob. 16-153 assuming the below-grade section of the wall is not insulated. *Answer: 3931 W*

16-155 A university campus has 200 classrooms and 400 faculty offices. The classrooms are equipped with 12 fluorescent light bulbs, each consuming 110 W, including the electricity used by the ballasts. The faculty offices, on average, have half as many light bulbs. The campus is open 240 days a year. The classrooms and faculty offices are not occupied an average of 4 hours a day, but the lights are kept on. If the unit cost of electricity is $\$0.075/\text{kWh}$, determine how much energy and money the campus will save a year if the lights in the classrooms and faculty offices are turned off during unoccupied periods.

16-156 It is believed that January is the coldest month in the Northern hemisphere. On the basis of Table 16-5, determine if this is true for all locations.

16-157 The December space heating bill of a fully occupied house in Louisville, Kentucky, that was kept at 22°C at all times was $\$110$. How much do you think the December space heating bill of this house would be if it still were kept at 22°C but there were no people living in the house, no lights were on, no appliances were operating, and there was no solar heat gain?

16-158 For an indoor temperature of 22°C , the design heating load of a residential building in Charlotte, North Carolina, is determined to be 28 kW. The house is to be heated by natural gas, which costs $\$1.20/\text{therm}$ (1 therm = 105,500 kJ). The efficiency of the gas furnace is 80 percent. Determine (a) the heat loss coefficient of the building, in $\text{kW}/^\circ\text{C}$, and (b) the annual energy usage for heating and its cost. *Answers: (a) 1 $\text{kW}/^\circ\text{C}$, (b) 1815 therms, $\$2178$*

Computer, Design, and Essay Problems

16-159 On average, superinsulated homes use just 15 percent of the fuel required to heat the same size conventional home built before the energy crises in the 1970s. Write an essay on superinsulated homes, and identify the features that make them so energy efficient as well as the problems associated with them. Do you think superinsulated homes will be economically attractive in your area?

16-160 Conduct the following experiment to determine the heat loss coefficient of your house or apartment in $W/^\circ C$. First make sure that the conditions in the house are steady and the house is at the set temperature of the thermostat. Use an outdoor thermometer to monitor outdoor temperature. One evening, using a watch or timer, determine how long the heater was on during a 3-h period and the average outdoor temperature during that period. Then using the heat output rating of your heater, determine the amount of heat supplied. Also, estimate the amount of heat generation in the house during that period by noting the number of people, the total wattage of lights that were on, and the heat generated by the appliances and equipment. Using that information, calculate the average rate of heat loss from the house and the heat loss coefficient.

16-161 Numerous professional software packages are available in the market for performing heat transfer analysis of buildings, and they are advertised in professional magazines such as the *ASHRAE Journal* magazine published by the American Society of Heating, Refrigerating, and Air-Conditioning Engineers (ASHRAE). Your company decides to purchase such a software package and asks you to prepare a report on the available packages, their costs, capabilities, ease of use, compatibility with the available hardware and other software, as well as the reputation of the software company, their history, financial health, customer support, training, and future prospects, among other things. After a preliminary investigation, select the top three packages and prepare a full report on them. Also, find out if there are any free software packages available that can be used for the same purpose.

16-162 A 1982 U.S. Department of Energy article (FS 204) states that a leak of one drip of hot water per second can cost \$1.00 per month. Making reasonable assumptions about the drop size and the unit cost of energy, determine if this claim is reasonable.

16-163 Obtain the following weather data for the city in which you live: the elevation, the atmospheric pressure, the number of heating and cooling degree-days, the 97.5 percent

level winter and summer design temperatures, the average annual and winter temperatures, the record high and low temperatures and when they occurred, and the unit cost of natural gas and electricity for residential buildings.

16-164 Your neighbor lives in a 250-m² older house heated by natural gas. The current gas heater was installed in the early 1970s and has an efficiency (called the annual fuel utilization efficiency, or AFUE), rating of 65 percent. It is time to replace the furnace, and the neighbor is trying to decide between a conventional furnace that has an efficiency of 80 percent and costs \$1500 and a high-efficiency furnace that has an efficiency of 95 percent and costs \$2500. Your neighbor offered to pay you \$100 if you help him make the right decision. Considering the weather data, typical heating loads, and the price of natural gas in your area, make a recommendation to your neighbor based on a convincing economic analysis.

16-165 The decision of whether to invest in an energy-saving measure is made on the basis of the length of time for it to pay for itself in projected energy (and thus cost) savings. The easiest way to reach a decision is to calculate the simple payback period by simply dividing the installed cost of the measure by the annual cost savings and comparing it to the lifetime of the installation. This approach is adequate for short payback periods (less than five years) in stable economies with low interest rates (under 10 percent) since the error involved is no larger than the uncertainties. However, if the payback period is long, it may be necessary to consider the *interest rate* if the money is to be borrowed, or the *rate of return* if the money is invested elsewhere instead of the energy conservation measure. For example, a simple payback period of five years corresponds to 5.0, 6.12, 6.64, 7.27, 8.09, 9.919, 10.84, and 13.91 for an interest rate (or return on investment) of 0, 6, 8, 10, 12, 14, 16, and 18 percent, respectively. Finding out the proper relations from engineering economics books, determine the payback periods for the interest rates given above corresponding to simple payback periods of 1 through 10 years.

16-166 A radiant heater mounted on the ceiling is to be designed to assist the heating of a 250-m² residence in Las Vegas, Nevada, whose walls are 4 m high. The indoor air is to be maintained at 15°C at all times, and the radiant heater is to provide thermal comfort for the sedentary occupants in light clothing. The system considered consists of hot water pipes buried in the ceiling and occupies the entire ceiling. Recommend a temperature for the ceiling, and estimate the energy consumption of the radiant heater. Does the radiant heater appear to save enough energy to justify its cost?

