

Basic Laws

There are too many people praying for mountains of difficulty to be removed, when what they really need is the courage to climb them!

—Unknown

Enhancing Your Skills and Your Career

ABET EC 2000 criteria (3.b), “an ability to design and conduct experiments, as well as to analyze and interpret data.”

Engineers must be able to design and conduct experiments, as well as analyze and interpret data. Most students have spent many hours performing experiments in high school and in college. During this time, you have been asked to analyze the data and to interpret the data. Therefore, you should already be skilled in these two activities. My recommendation is that, in the process of performing experiments in the future, you spend more time in analyzing and interpreting the data in the context of the experiment. What does this mean?

If you are looking at a plot of voltage versus resistance or current versus resistance or power versus resistance, what do you actually see? Does the curve make sense? Does it agree with what the theory tells you? Does it differ from expectation, and, if so, why? Clearly, practice with analyzing and interpreting data will enhance this skill.

Since most, if not all, the experiments you are required to do as a student involve little or no practice in designing the experiment, how can you develop and enhance this skill?

Actually, developing this skill under this constraint is not as difficult as it seems. What you need to do is to take the experiment and analyze it. Just break it down into its simplest parts, reconstruct it trying to understand why each element is there, and finally, determine what the author of the experiment is trying to teach you. Even though it may not always seem so, every experiment you do was designed by someone who was sincerely motivated to teach you something.

2.1 Introduction

Chapter 1 introduced basic concepts such as current, voltage, and power in an electric circuit. To actually determine the values of these variables in a given circuit requires that we understand some fundamental laws that govern electric circuits. These laws, known as Ohm's law and Kirchhoff's laws, form the foundation upon which electric circuit analysis is built.

In this chapter, in addition to these laws, we shall discuss some techniques commonly applied in circuit design and analysis. These techniques include combining resistors in series or parallel, voltage division, current division, and delta-to-wye and wye-to-delta transformations. The application of these laws and techniques will be restricted to resistive circuits in this chapter. We will finally apply the laws and techniques to real-life problems of electrical lighting and the design of dc meters.

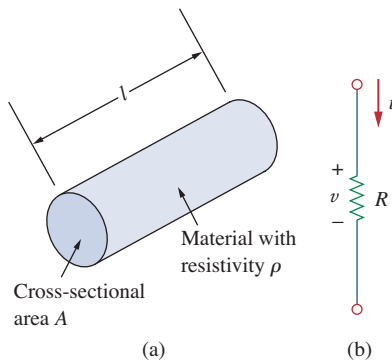

Figure 2.1

(a) Resistor, (b) Circuit symbol for resistance.

2.2 Ohm's Law

Materials in general have a characteristic behavior of resisting the flow of electric charge. This physical property, or ability to resist current, is known as *resistance* and is represented by the symbol R . The resistance of any material with a uniform cross-sectional area A depends on A and its length ℓ , as shown in Fig. 2.1(a). We can represent resistance (as measured in the laboratory), in mathematical form,

$$R = \rho \frac{\ell}{A} \quad (2.1)$$

where ρ is known as the *resistivity* of the material in ohm-meters. Good conductors, such as copper and aluminum, have low resistivities, while insulators, such as mica and paper, have high resistivities. Table 2.1 presents the values of ρ for some common materials and shows which materials are used for conductors, insulators, and semiconductors.

The circuit element used to model the current-resisting behavior of a material is the *resistor*. For the purpose of constructing circuits, resistors are usually made from metallic alloys and carbon compounds. The circuit

TABLE 2.1

Resistivities of common materials.

Material	Resistivity ($\Omega \cdot \text{m}$)	Usage
Silver	1.64×10^{-8}	Conductor
Copper	1.72×10^{-8}	Conductor
Aluminum	2.8×10^{-8}	Conductor
Gold	2.45×10^{-8}	Conductor
Carbon	4×10^{-5}	Semiconductor
Germanium	47×10^{-2}	Semiconductor
Silicon	6.4×10^2	Semiconductor
Paper	10^{10}	Insulator
Mica	5×10^{11}	Insulator
Glass	10^{12}	Insulator
Teflon	3×10^{12}	Insulator

symbol for the resistor is shown in Fig. 2.1(b), where R stands for the resistance of the resistor. The resistor is the simplest passive element.

Georg Simon Ohm (1787–1854), a German physicist, is credited with finding the relationship between current and voltage for a resistor. This relationship is known as *Ohm's law*.

Ohm's law states that the voltage v across a resistor is directly proportional to the current i flowing through the resistor.

That is,

$$v \propto i \quad (2.2)$$

Ohm defined the constant of proportionality for a resistor to be the resistance, R . (The resistance is a material property which can change if the internal or external conditions of the element are altered, e.g., if there are changes in the temperature.) Thus, Eq. (2.2) becomes

$$v = iR \quad (2.3)$$

which is the mathematical form of Ohm's law. R in Eq. (2.3) is measured in the unit of ohms, designated Ω . Thus,

The *resistance* R of an element denotes its ability to resist the flow of electric current; it is measured in ohms (Ω).

We may deduce from Eq. (2.3) that

$$R = \frac{v}{i} \quad (2.4)$$

so that

$$1 \Omega = 1 \text{ V/A}$$

To apply Ohm's law as stated in Eq. (2.3), we must pay careful attention to the current direction and voltage polarity. The direction of current i and the polarity of voltage v must conform with the passive

Historical

Georg Simon Ohm (1787–1854), a German physicist, in 1826 experimentally determined the most basic law relating voltage and current for a resistor. Ohm's work was initially denied by critics.

Born of humble beginnings in Erlangen, Bavaria, Ohm threw himself into electrical research. His efforts resulted in his famous law. He was awarded the Copley Medal in 1841 by the Royal Society of London. In 1849, he was given the Professor of Physics chair by the University of Munich. To honor him, the unit of resistance was named the ohm.



© SSPL via Getty Images

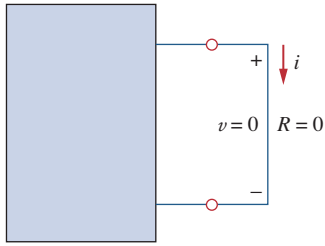

(a)

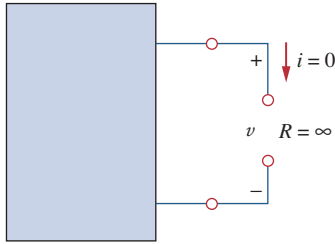

(b)

Figure 2.2

(a) Short circuit ($R = 0$), (b) Open circuit ($R = \infty$).

sign convention, as shown in Fig. 2.1(b). This implies that current flows from a higher potential to a lower potential in order for $v = iR$. If current flows from a lower potential to a higher potential, $v = -iR$.

Since the value of R can range from zero to infinity, it is important that we consider the two extreme possible values of R . An element with $R = 0$ is called a *short circuit*, as shown in Fig. 2.2(a). For a short circuit,

$$v = iR = 0 \tag{2.5}$$

showing that the voltage is zero but the current could be anything. In practice, a short circuit is usually a connecting wire assumed to be a perfect conductor. Thus,

A **short circuit** is a circuit element with resistance approaching zero.

Similarly, an element with $R = \infty$ is known as an *open circuit*, as shown in Fig. 2.2(b). For an open circuit,

$$i = \lim_{R \rightarrow \infty} \frac{v}{R} = 0 \tag{2.6}$$

indicating that the current is zero though the voltage could be anything. Thus,

An **open circuit** is a circuit element with resistance approaching infinity.

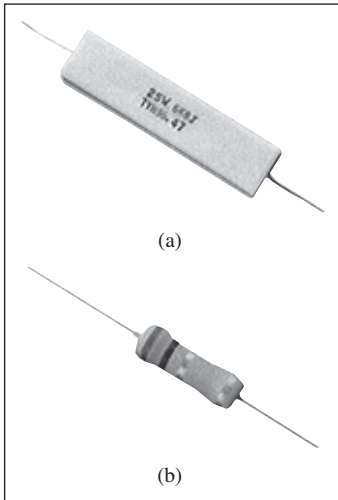

Figure 2.3

Fixed resistors: (a) wirewound type, (b) carbon film type. Courtesy of Tech America.

A resistor is either fixed or variable. Most resistors are of the fixed type, meaning their resistance remains constant. The two common types of fixed resistors (wirewound and composition) are shown in Fig. 2.3. The composition resistors are used when large resistance is needed. The circuit symbol in Fig. 2.1(b) is for a fixed resistor. Variable resistors have adjustable resistance. The symbol for a variable resistor is shown in Fig. 2.4(a). A common variable resistor is known as a *potentiometer* or *pot* for short, with the symbol shown in Fig. 2.4(b). The pot is a three-terminal element with a sliding contact or wiper. By sliding the wiper, the resistances between the wiper terminal and the fixed terminals vary. Like fixed resistors, variable resistors can be of either wirewound or composition type, as shown in Fig. 2.5. Although resistors like those in Figs. 2.3 and 2.5 are used in circuit designs, today most

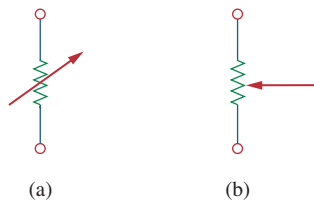

Figure 2.4

Circuit symbol for: (a) a variable resistor in general, (b) a potentiometer.

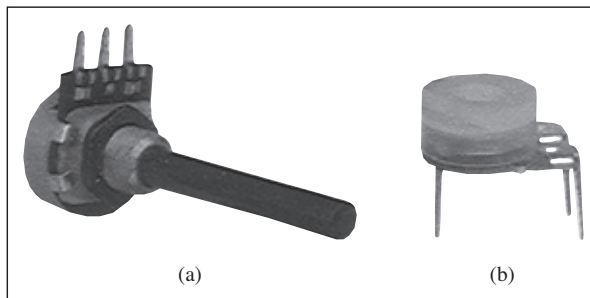

Figure 2.5

Variable resistors: (a) composition type, (b) slider pot. Courtesy of Tech America.

circuit components including resistors are either surface mounted or integrated, as typically shown in Fig. 2.6.

It should be pointed out that not all resistors obey Ohm's law. A resistor that obeys Ohm's law is known as a *linear* resistor. It has a constant resistance and thus its current-voltage characteristic is as illustrated in Fig. 2.7(a): Its i - v graph is a straight line passing through the origin. A *nonlinear* resistor does not obey Ohm's law. Its resistance varies with current and its i - v characteristic is typically shown in Fig. 2.7(b). Examples of devices with nonlinear resistance are the light bulb and the diode. Although all practical resistors may exhibit nonlinear behavior under certain conditions, we will assume in this book that all elements actually designated as resistors are linear.

A useful quantity in circuit analysis is the reciprocal of resistance R , known as *conductance* and denoted by G :

$$G = \frac{1}{R} = \frac{i}{v} \quad (2.7)$$

The conductance is a measure of how well an element will conduct electric current. The unit of conductance is the *mho* (ohm spelled backward) or reciprocal ohm, with symbol \mathcal{U} , the inverted omega. Although engineers often use the mho, in this book we prefer to use the siemens (S), the SI unit of conductance:

$$1 \text{ S} = 1 \mathcal{U} = 1 \text{ A/V} \quad (2.8)$$

Thus,

Conductance is the ability of an element to conduct electric current; it is measured in mhos (\mathcal{U}) or siemens (S).

The same resistance can be expressed in ohms or siemens. For example, 10Ω is the same as 0.1 S . From Eq. (2.7), we may write

$$i = Gv \quad (2.9)$$

The power dissipated by a resistor can be expressed in terms of R . Using Eqs. (1.7) and (2.3),

$$p = vi = i^2R = \frac{v^2}{R} \quad (2.10)$$

The power dissipated by a resistor may also be expressed in terms of G as

$$p = vi = v^2G = \frac{i^2}{G} \quad (2.11)$$

We should note two things from Eqs. (2.10) and (2.11):

1. The power dissipated in a resistor is a nonlinear function of either current or voltage.
2. Since R and G are positive quantities, the power dissipated in a resistor is always positive. Thus, a resistor always absorbs power from the circuit. This confirms the idea that a resistor is a passive element, incapable of generating energy.



Figure 2.6

Resistors in an integrated circuit board.

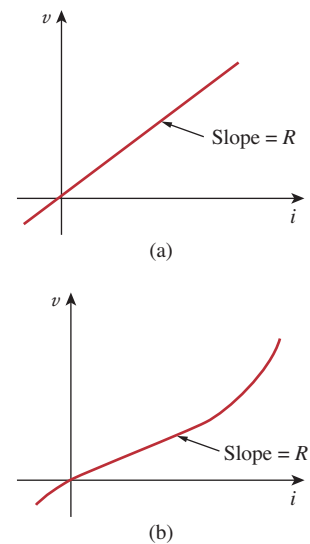

Figure 2.7

The i - v characteristic of: (a) a linear resistor, (b) a nonlinear resistor.

Example 2.1

An electric iron draws 2 A at 120 V. Find its resistance.

Solution:

From Ohm's law,

$$R = \frac{v}{i} = \frac{120}{2} = 60 \Omega$$

Practice Problem 2.1

The essential component of a toaster is an electrical element (a resistor) that converts electrical energy to heat energy. How much current is drawn by a toaster with resistance 15Ω at 110 V ?

Answer: 7.333 A.

Example 2.2

Figure 2.8
For Example 2.2.

In the circuit shown in Fig. 2.8, calculate the current i , the conductance G , and the power p .

Solution:

The voltage across the resistor is the same as the source voltage (30 V) because the resistor and the voltage source are connected to the same pair of terminals. Hence, the current is

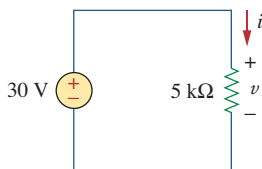
$$i = \frac{v}{R} = \frac{30}{5 \times 10^3} = 6 \text{ mA}$$

The conductance is

$$G = \frac{1}{R} = \frac{1}{5 \times 10^3} = 0.2 \text{ mS}$$

We can calculate the power in various ways using either Eqs. (1.7), (2.10), or (2.11).

$$p = vi = 30(6 \times 10^{-3}) = 180 \text{ mW}$$

or

$$p = i^2R = (6 \times 10^{-3})^2 5 \times 10^3 = 180 \text{ mW}$$

or

$$p = v^2G = (30)^2 0.2 \times 10^{-3} = 180 \text{ mW}$$

Practice Problem 2.2

Figure 2.9
For Practice Prob. 2.2

For the circuit shown in Fig. 2.9, calculate the voltage v , the conductance G , and the power p .

Answer: 30 V, $100 \mu\text{S}$, 90 mW.

A voltage source of $20 \sin \pi t$ V is connected across a $5\text{-k}\Omega$ resistor. Find the current through the resistor and the power dissipated.

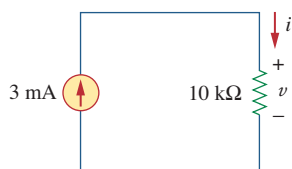
Example 2.3

Solution:

$$i = \frac{v}{R} = \frac{20 \sin \pi t}{5 \times 10^3} = 4 \sin \pi t \text{ mA}$$

Hence,

$$p = vi = 80 \sin^2 \pi t \text{ mW}$$

A resistor absorbs an instantaneous power of $30 \cos^2 t$ mW when connected to a voltage source $v = 15 \cos t$ V. Find i and R .

Practice Problem 2.3

Answer: $2 \cos t$ mA, $7.5 \text{ k}\Omega$.

2.3 † Nodes, Branches, and Loops

Since the elements of an electric circuit can be interconnected in several ways, we need to understand some basic concepts of network topology. To differentiate between a circuit and a network, we may regard a network as an interconnection of elements or devices, whereas a circuit is a network providing one or more closed paths. The convention, when addressing network topology, is to use the word network rather than circuit. We do this even though the word network and circuit mean the same thing when used in this context. In network topology, we study the properties relating to the placement of elements in the network and the geometric configuration of the network. Such elements include branches, nodes, and loops.

A **branch** represents a single element such as a voltage source or a resistor.

In other words, a branch represents any two-terminal element. The circuit in Fig. 2.10 has five branches, namely, the 10-V voltage source, the 2-A current source, and the three resistors.

A **node** is the point of connection between two or more branches.

A node is usually indicated by a dot in a circuit. If a short circuit (a connecting wire) connects two nodes, the two nodes constitute a single node. The circuit in Fig. 2.10 has three nodes a , b , and c . Notice that the three points that form node b are connected by perfectly conducting wires and therefore constitute a single point. The same is true of the four points forming node c . We demonstrate that the circuit in Fig. 2.10 has only three nodes by redrawing the circuit in Fig. 2.11. The two circuits in Figs. 2.10 and 2.11 are identical. However, for the sake of clarity, nodes b and c are spread out with perfect conductors as in Fig. 2.10.

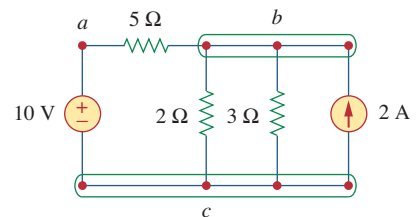

Figure 2.10
Nodes, branches, and loops.

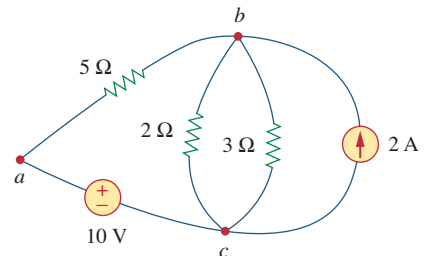

Figure 2.11
The three-node circuit of Fig. 2.10 is redrawn.

A **loop** is any closed path in a circuit.

A loop is a closed path formed by starting at a node, passing through a set of nodes, and returning to the starting node without passing through any node more than once. A loop is said to be *independent* if it contains at least one branch which is not a part of any other independent loop. Independent loops or paths result in independent sets of equations.

It is possible to form an independent set of loops where one of the loops does not contain such a branch. In Fig. 2.11, *abca* with the 2Ω resistor is independent. A second loop with the 3Ω resistor and the current source is independent. The third loop could be the one with the 2Ω resistor in parallel with the 3Ω resistor. This does form an independent set of loops.

A network with b branches, n nodes, and l independent loops will satisfy the fundamental theorem of network topology:

$$b = l + n - 1 \quad (2.12)$$

As the next two definitions show, circuit topology is of great value to the study of voltages and currents in an electric circuit.

Two or more elements are in **series** if they exclusively share a single node and consequently carry the same current.

Two or more elements are in **parallel** if they are connected to the same two nodes and consequently have the same voltage across them.

Elements are in series when they are chain-connected or connected sequentially, end to end. For example, two elements are in series if they share one common node and no other element is connected to that common node. Elements in parallel are connected to the same pair of terminals. Elements may be connected in a way that they are neither in series nor in parallel. In the circuit shown in Fig. 2.10, the voltage source and the $5\text{-}\Omega$ resistor are in series because the same current will flow through them. The $2\text{-}\Omega$ resistor, the $3\text{-}\Omega$ resistor, and the current source are in parallel because they are connected to the same two nodes b and c and consequently have the same voltage across them. The $5\text{-}\Omega$ and $2\text{-}\Omega$ resistors are neither in series nor in parallel with each other.

Example 2.4

Determine the number of branches and nodes in the circuit shown in Fig. 2.12. Identify which elements are in series and which are in parallel.

Solution:

Since there are four elements in the circuit, the circuit has four branches: 10 V , $5\text{ }\Omega$, $6\text{ }\Omega$, and 2 A . The circuit has three nodes as identified in Fig. 2.13. The $5\text{-}\Omega$ resistor is in series with the 10-V voltage source because the same current would flow in both. The $6\text{-}\Omega$ resistor is in parallel with the 2-A current source because both are connected to the same nodes 2 and 3.

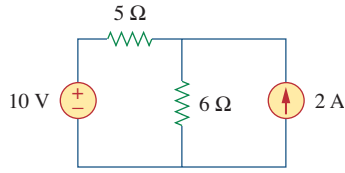

Figure 2.12
For Example 2.4.

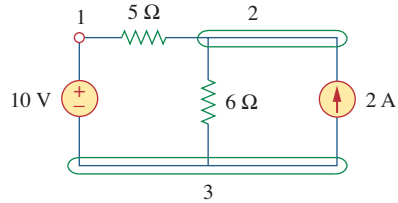

Figure 2.13
The three nodes in the circuit of
Fig. 2.12.

How many branches and nodes does the circuit in Fig. 2.14 have? Identify the elements that are in series and in parallel.

Practice Problem 2.4

Answer: Five branches and three nodes are identified in Fig. 2.15. The 1-Ω and 2-Ω resistors are in parallel. The 4-Ω resistor and 10-V source are also in parallel.

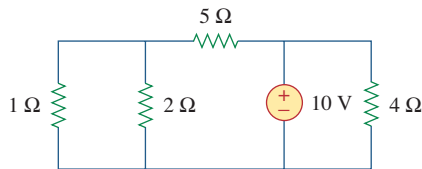

Figure 2.14
For Practice Prob. 2.4.

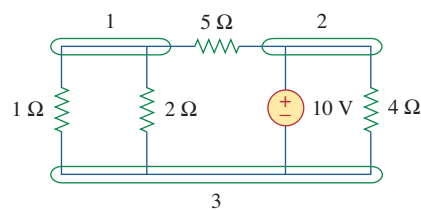

Figure 2.15
Answer for Practice Prob. 2.4.

2.4 Kirchhoff's Laws

Ohm's law by itself is not sufficient to analyze circuits. However, when it is coupled with Kirchhoff's two laws, we have a sufficient, powerful set of tools for analyzing a large variety of electric circuits. Kirchhoff's laws were first introduced in 1847 by the German physicist Gustav Robert Kirchhoff (1824–1887). These laws are formally known as Kirchhoff's current law (KCL) and Kirchhoff's voltage law (KVL).

Kirchhoff's first law is based on the law of conservation of charge, which requires that the algebraic sum of charges within a system cannot change.

Kirchhoff's current law (KCL) states that the algebraic sum of currents entering a node (or a closed boundary) is zero.

Mathematically, KCL implies that

$$\sum_{n=1}^N i_n = 0 \quad (2.13)$$

where N is the number of branches connected to the node and i_n is the n th current entering (or leaving) the node. By this law, currents

Historical



© Pixtal/age Fotostock RF

Gustav Robert Kirchhoff (1824–1887), a German physicist, stated two basic laws in 1847 concerning the relationship between the currents and voltages in an electrical network. Kirchhoff's laws, along with Ohm's law, form the basis of circuit theory.

Born the son of a lawyer in Königsberg, East Prussia, Kirchhoff entered the University of Königsberg at age 18 and later became a lecturer in Berlin. His collaborative work in spectroscopy with German chemist Robert Bunsen led to the discovery of cesium in 1860 and rubidium in 1861. Kirchhoff was also credited with the Kirchhoff law of radiation. Thus Kirchhoff is famous among engineers, chemists, and physicists.

entering a node may be regarded as positive, while currents leaving the node may be taken as negative or vice versa.

To prove KCL, assume a set of currents $i_k(t)$, $k = 1, 2, \dots$, flow into a node. The algebraic sum of currents at the node is

$$i_T(t) = i_1(t) + i_2(t) + i_3(t) + \dots \quad (2.14)$$

Integrating both sides of Eq. (2.14) gives

$$q_T(t) = q_1(t) + q_2(t) + q_3(t) + \dots \quad (2.15)$$

where $q_k(t) = \int i_k(t) dt$ and $q_T(t) = \int i_T(t) dt$. But the law of conservation of electric charge requires that the algebraic sum of electric charges at the node must not change; that is, the node stores no net charge. Thus $q_T(t) = 0 \rightarrow i_T(t) = 0$, confirming the validity of KCL.

Consider the node in Fig. 2.16. Applying KCL gives

$$i_1 + (-i_2) + i_3 + i_4 + (-i_5) = 0 \quad (2.16)$$

since currents i_1 , i_3 , and i_4 are entering the node, while currents i_2 and i_5 are leaving it. By rearranging the terms, we get

$$i_1 + i_3 + i_4 = i_2 + i_5 \quad (2.17)$$

Equation (2.17) is an alternative form of KCL:

The sum of the currents entering a node is equal to the sum of the currents leaving the node.

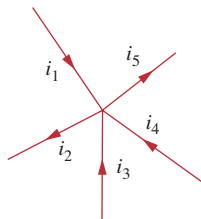

Figure 2.16

Currents at a node illustrating KCL.

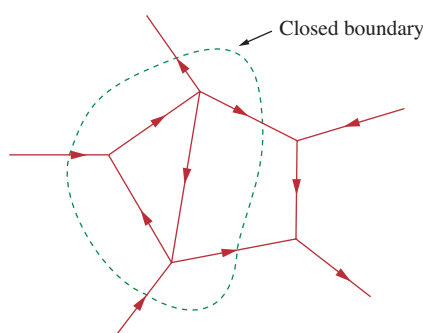

Figure 2.17

Applying KCL to a closed boundary.

Two sources (or circuits in general) are said to be equivalent if they have the same i - v relationship at a pair of terminals.

Note that KCL also applies to a closed boundary. This may be regarded as a generalized case, because a node may be regarded as a closed surface shrunk to a point. In two dimensions, a closed boundary is the same as a closed path. As typically illustrated in the circuit of Fig. 2.17, the total current entering the closed surface is equal to the total current leaving the surface.

A simple application of KCL is combining current sources in parallel. The combined current is the algebraic sum of the current supplied by the individual sources. For example, the current sources shown in

Fig. 2.18(a) can be combined as in Fig. 2.18(b). The combined or equivalent current source can be found by applying KCL to node a .

$$I_T + I_2 = I_1 + I_3$$

or

$$I_T = I_1 - I_2 + I_3 \quad (2.18)$$

A circuit cannot contain two different currents, I_1 and I_2 , in series, unless $I_1 = I_2$; otherwise KCL will be violated.

Kirchhoff's second law is based on the principle of conservation of energy:

Kirchhoff's voltage law (KVL) states that the algebraic sum of all voltages around a closed path (or loop) is zero.

Expressed mathematically, KVL states that

$$\sum_{m=1}^M v_m = 0 \quad (2.19)$$

where M is the number of voltages in the loop (or the number of branches in the loop) and v_m is the m th voltage.

To illustrate KVL, consider the circuit in Fig. 2.19. The sign on each voltage is the polarity of the terminal encountered first as we travel around the loop. We can start with any branch and go around the loop either clockwise or counterclockwise. Suppose we start with the voltage source and go clockwise around the loop as shown; then voltages would be $-v_1, +v_2, +v_3, -v_4,$ and $+v_5$, in that order. For example, as we reach branch 3, the positive terminal is met first; hence, we have $+v_3$. For branch 4, we reach the negative terminal first; hence, $-v_4$. Thus, KVL yields

$$-v_1 + v_2 + v_3 - v_4 + v_5 = 0 \quad (2.20)$$

Rearranging terms gives

$$v_2 + v_3 + v_5 = v_1 + v_4 \quad (2.21)$$

which may be interpreted as

$$\text{Sum of voltage drops} = \text{Sum of voltage rises} \quad (2.22)$$

This is an alternative form of KVL. Notice that if we had traveled counterclockwise, the result would have been $+v_1, -v_5, +v_4, -v_3,$ and $-v_2$, which is the same as before except that the signs are reversed. Hence, Eqs. (2.20) and (2.21) remain the same.

When voltage sources are connected in series, KVL can be applied to obtain the total voltage. The combined voltage is the algebraic sum of the voltages of the individual sources. For example, for the voltage sources shown in Fig. 2.20(a), the combined or equivalent voltage source in Fig. 2.20(b) is obtained by applying KVL.

$$-V_{ab} + V_1 + V_2 - V_3 = 0$$

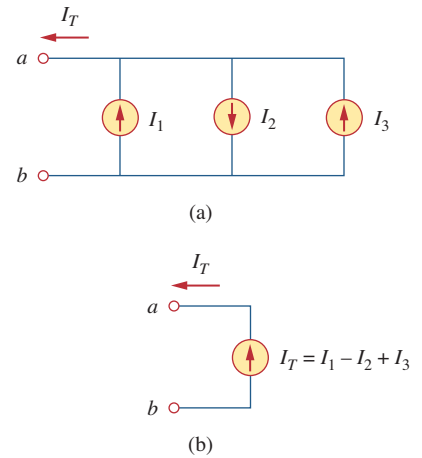

Figure 2.18

Current sources in parallel: (a) original circuit, (b) equivalent circuit.

KVL can be applied in two ways: by taking either a clockwise or a counterclockwise trip around the loop. Either way, the algebraic sum of voltages around the loop is zero.

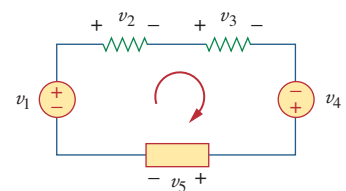

Figure 2.19

A single-loop circuit illustrating KVL.

or

$$V_{ab} = V_1 + V_2 - V_3 \quad (2.23)$$

To avoid violating KVL, a circuit cannot contain two different voltages V_1 and V_2 in parallel unless $V_1 = V_2$.

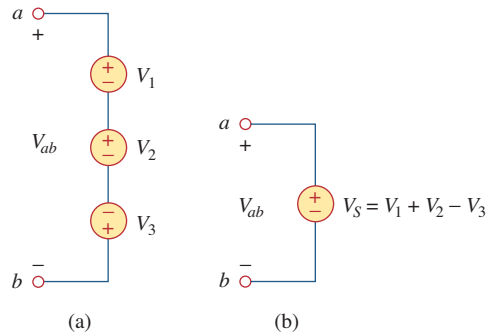

Figure 2.20

Voltage sources in series: (a) original circuit, (b) equivalent circuit.

Example 2.5

For the circuit in Fig. 2.21(a), find voltages v_1 and v_2 .

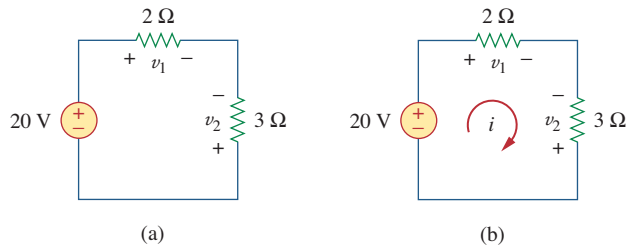

Figure 2.21

For Example 2.5.

Solution:

To find v_1 and v_2 , we apply Ohm's law and Kirchhoff's voltage law. Assume that current i flows through the loop as shown in Fig. 2.21(b). From Ohm's law,

$$v_1 = 2i, \quad v_2 = -3i \quad (2.5.1)$$

Applying KVL around the loop gives

$$-20 + v_1 - v_2 = 0 \quad (2.5.2)$$

Substituting Eq. (2.5.1) into Eq. (2.5.2), we obtain

$$-20 + 2i + 3i = 0 \quad \text{or} \quad 5i = 20 \quad \Rightarrow \quad i = 4 \text{ A}$$

Substituting i in Eq. (2.5.1) finally gives

$$v_1 = 8 \text{ V}, \quad v_2 = -12 \text{ V}$$

Find v_1 and v_2 in the circuit of Fig. 2.22.

Answer: 16 V, -8 V.

Practice Problem 2.5

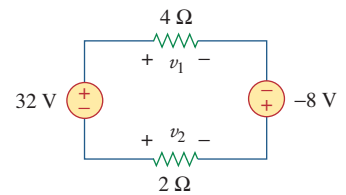

Figure 2.22
For Practice Prob. 2.5.

Determine v_o and i in the circuit shown in Fig. 2.23(a).

Example 2.6

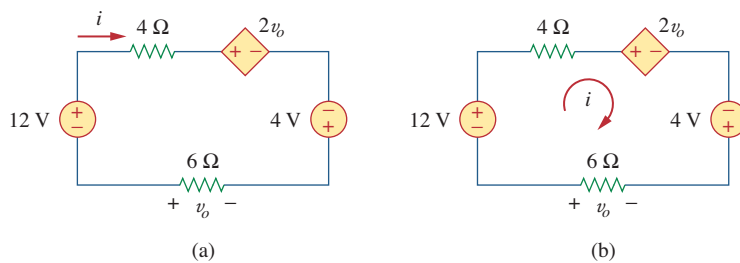

Figure 2.23
For Example 2.6.

Solution:

We apply KVL around the loop as shown in Fig. 2.23(b). The result is

$$-12 + 4i + 2v_o - 4 + 6i = 0 \quad (2.6.1)$$

Applying Ohm's law to the 6-Ω resistor gives

$$v_o = -6i \quad (2.6.2)$$

Substituting Eq. (2.6.2) into Eq. (2.6.1) yields

$$-16 + 10i - 12i = 0 \quad \Rightarrow \quad i = -8 \text{ A}$$

and $v_o = 48 \text{ V}$.

Find v_x and v_o in the circuit of Fig. 2.24.

Practice Problem 2.6

Answer: 20 V, -10 V.

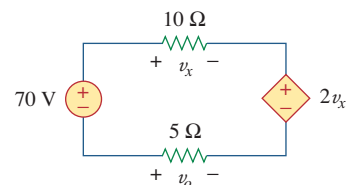
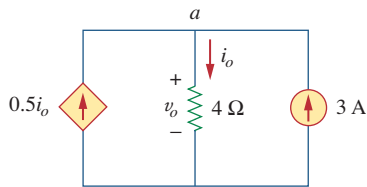

Figure 2.24
For Practice Prob. 2.6.

Example 2.7Find current i_o and voltage v_o in the circuit shown in Fig. 2.25.**Figure 2.25**

For Example 2.7.

Solution:Applying KCL to node a , we obtain

$$3 + 0.5i_o = i_o \quad \Rightarrow \quad i_o = 6 \text{ A}$$

For the $4\text{-}\Omega$ resistor, Ohm's law gives

$$v_o = 4i_o = 24 \text{ V}$$

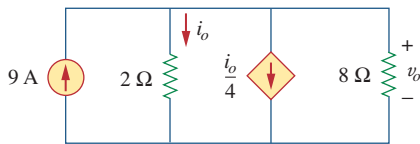
Practice Problem 2.7Find v_o and i_o in the circuit of Fig. 2.26.**Figure 2.26**

For Practice Prob. 2.7.

Answer: 12 V, 6 A.**Example 2.8**

Find currents and voltages in the circuit shown in Fig. 2.27(a).

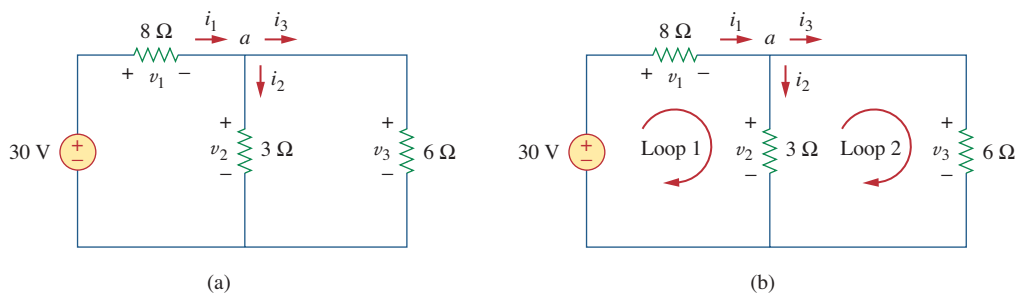
**Figure 2.27**

For Example 2.8.

Solution:

We apply Ohm's law and Kirchhoff's laws. By Ohm's law,

$$v_1 = 8i_1, \quad v_2 = 3i_2, \quad v_3 = 6i_3 \quad (2.8.1)$$

Since the voltage and current of each resistor are related by Ohm's law as shown, we are really looking for three things: (v_1, v_2, v_3) or (i_1, i_2, i_3) . At node a , KCL gives

$$i_1 - i_2 - i_3 = 0 \quad (2.8.2)$$

Applying KVL to loop 1 as in Fig. 2.27(b),

$$-30 + v_1 + v_2 = 0$$

We express this in terms of i_1 and i_2 as in Eq. (2.8.1) to obtain

$$-30 + 8i_1 + 3i_2 = 0$$

or

$$i_1 = \frac{(30 - 3i_2)}{8} \quad (2.8.3)$$

Applying KVL to loop 2,

$$-v_2 + v_3 = 0 \quad \Rightarrow \quad v_3 = v_2 \quad (2.8.4)$$

as expected since the two resistors are in parallel. We express v_1 and v_2 in terms of i_1 and i_2 as in Eq. (2.8.1). Equation (2.8.4) becomes

$$6i_3 = 3i_2 \quad \Rightarrow \quad i_3 = \frac{i_2}{2} \quad (2.8.5)$$

Substituting Eqs. (2.8.3) and (2.8.5) into (2.8.2) gives

$$\frac{30 - 3i_2}{8} - i_2 - \frac{i_2}{2} = 0$$

or $i_2 = 2$ A. From the value of i_2 , we now use Eqs. (2.8.1) to (2.8.5) to obtain

$$i_1 = 3 \text{ A}, \quad i_3 = 1 \text{ A}, \quad v_1 = 24 \text{ V}, \quad v_2 = 6 \text{ V}, \quad v_3 = 6 \text{ V}$$

Find the currents and voltages in the circuit shown in Fig. 2.28.

Answer: $v_1 = 6$ V, $v_2 = 4$ V, $v_3 = 10$ V, $i_1 = 3$ A, $i_2 = 500$ mA, $i_3 = 1.25$ A.

Practice Problem 2.8

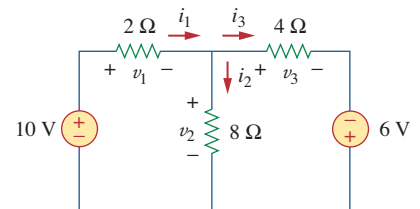
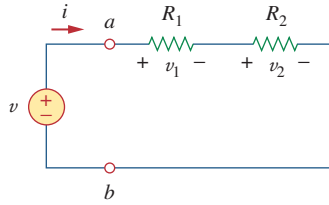

Figure 2.28
For Practice Prob. 2.8.

2.5 Series Resistors and Voltage Division

The need to combine resistors in series or in parallel occurs so frequently that it warrants special attention. The process of combining the resistors is facilitated by combining two of them at a time. With this in mind, consider the single-loop circuit of Fig. 2.29. The two resistors

**Figure 2.29**

A single-loop circuit with two resistors in series.

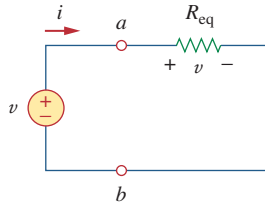
**Figure 2.30**

Equivalent circuit of the Fig. 2.29 circuit.

Resistors in series behave as a single resistor whose resistance is equal to the sum of the resistances of the individual resistors.

are in series, since the same current i flows in both of them. Applying Ohm's law to each of the resistors, we obtain

$$v_1 = iR_1, \quad v_2 = iR_2 \quad (2.24)$$

If we apply KVL to the loop (moving in the clockwise direction), we have

$$-v + v_1 + v_2 = 0 \quad (2.25)$$

Combining Eqs. (2.24) and (2.25), we get

$$v = v_1 + v_2 = i(R_1 + R_2) \quad (2.26)$$

or

$$i = \frac{v}{R_1 + R_2} \quad (2.27)$$

Notice that Eq. (2.26) can be written as

$$v = iR_{\text{eq}} \quad (2.28)$$

implying that the two resistors can be replaced by an equivalent resistor R_{eq} ; that is,

$$R_{\text{eq}} = R_1 + R_2 \quad (2.29)$$

Thus, Fig. 2.29 can be replaced by the equivalent circuit in Fig. 2.30. The two circuits in Figs. 2.29 and 2.30 are equivalent because they exhibit the same voltage-current relationships at the terminals a - b . An equivalent circuit such as the one in Fig. 2.30 is useful in simplifying the analysis of a circuit. In general,

The **equivalent resistance** of any number of resistors connected in series is the sum of the individual resistances.

For N resistors in series then,

$$R_{\text{eq}} = R_1 + R_2 + \cdots + R_N = \sum_{n=1}^N R_n \quad (2.30)$$

To determine the voltage across each resistor in Fig. 2.29, we substitute Eq. (2.26) into Eq. (2.24) and obtain

$$v_1 = \frac{R_1}{R_1 + R_2} v, \quad v_2 = \frac{R_2}{R_1 + R_2} v \quad (2.31)$$

Notice that the source voltage v is divided among the resistors in direct proportion to their resistances; the larger the resistance, the larger the voltage drop. This is called the *principle of voltage division*, and the circuit in Fig. 2.29 is called a *voltage divider*. In general, if a voltage divider has N resistors (R_1, R_2, \dots, R_N) in series with the source voltage v , the n th resistor (R_n) will have a voltage drop of

$$v_n = \frac{R_n}{R_1 + R_2 + \cdots + R_N} v \quad (2.32)$$

2.6 Parallel Resistors and Current Division

Consider the circuit in Fig. 2.31, where two resistors are connected in parallel and therefore have the same voltage across them. From Ohm's law,

$$v = i_1 R_1 = i_2 R_2$$

or

$$i_1 = \frac{v}{R_1}, \quad i_2 = \frac{v}{R_2} \quad (2.33)$$

Applying KCL at node a gives the total current i as

$$i = i_1 + i_2 \quad (2.34)$$

Substituting Eq. (2.33) into Eq. (2.34), we get

$$i = \frac{v}{R_1} + \frac{v}{R_2} = v \left(\frac{1}{R_1} + \frac{1}{R_2} \right) = \frac{v}{R_{\text{eq}}} \quad (2.35)$$

where R_{eq} is the equivalent resistance of the resistors in parallel:

$$\frac{1}{R_{\text{eq}}} = \frac{1}{R_1} + \frac{1}{R_2} \quad (2.36)$$

or

$$\frac{1}{R_{\text{eq}}} = \frac{R_1 + R_2}{R_1 R_2}$$

or

$$R_{\text{eq}} = \frac{R_1 R_2}{R_1 + R_2} \quad (2.37)$$

Thus,

The **equivalent resistance** of two parallel resistors is equal to the product of their resistances divided by their sum.

It must be emphasized that this applies only to two resistors in parallel. From Eq. (2.37), if $R_1 = R_2$, then $R_{\text{eq}} = R_1/2$.

We can extend the result in Eq. (2.36) to the general case of a circuit with N resistors in parallel. The equivalent resistance is

$$\frac{1}{R_{\text{eq}}} = \frac{1}{R_1} + \frac{1}{R_2} + \cdots + \frac{1}{R_N} \quad (2.38)$$

Note that R_{eq} is always smaller than the resistance of the smallest resistor in the parallel combination. If $R_1 = R_2 = \cdots = R_N = R$, then

$$R_{\text{eq}} = \frac{R}{N} \quad (2.39)$$

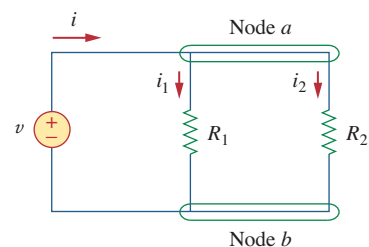

Figure 2.31
Two resistors in parallel.

Conductances in parallel behave as a single conductance whose value is equal to the sum of the individual conductances.

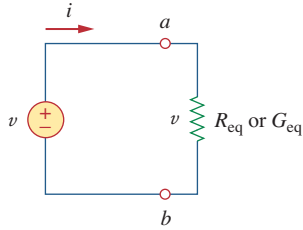

Figure 2.32
Equivalent circuit to Fig. 2.31.

For example, if four $100\text{-}\Omega$ resistors are connected in parallel, their equivalent resistance is $25\ \Omega$.

It is often more convenient to use conductance rather than resistance when dealing with resistors in parallel. From Eq. (2.38), the equivalent conductance for N resistors in parallel is

$$G_{\text{eq}} = G_1 + G_2 + G_3 + \cdots + G_N \quad (2.40)$$

where $G_{\text{eq}} = 1/R_{\text{eq}}$, $G_1 = 1/R_1$, $G_2 = 1/R_2$, $G_3 = 1/R_3$, ..., $G_N = 1/R_N$. Equation (2.40) states:

The **equivalent conductance** of resistors connected in parallel is the sum of their individual conductances.

This means that we may replace the circuit in Fig. 2.31 with that in Fig. 2.32. Notice the similarity between Eqs. (2.30) and (2.40). The equivalent conductance of parallel resistors is obtained the same way as the equivalent resistance of series resistors. In the same manner, the equivalent conductance of resistors in series is obtained just the same way as the resistance of resistors in parallel. Thus the equivalent conductance G_{eq} of N resistors in series (such as shown in Fig. 2.29) is

$$\frac{1}{G_{\text{eq}}} = \frac{1}{G_1} + \frac{1}{G_2} + \frac{1}{G_3} + \cdots + \frac{1}{G_N} \quad (2.41)$$

Given the total current i entering node a in Fig. 2.31, how do we obtain current i_1 and i_2 ? We know that the equivalent resistor has the same voltage, or

$$v = iR_{\text{eq}} = \frac{iR_1R_2}{R_1 + R_2} \quad (2.42)$$

Combining Eqs. (2.33) and (2.42) results in

$$i_1 = \frac{R_2 i}{R_1 + R_2}, \quad i_2 = \frac{R_1 i}{R_1 + R_2} \quad (2.43)$$

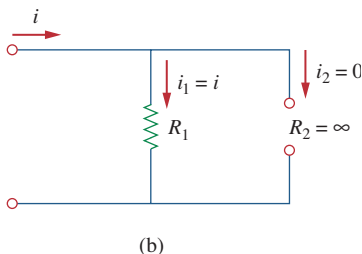
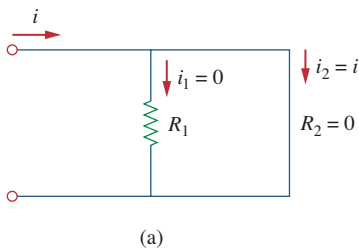

Figure 2.33
(a) A shorted circuit, (b) an open circuit.

which shows that the total current i is shared by the resistors in inverse proportion to their resistances. This is known as the *principle of current division*, and the circuit in Fig. 2.31 is known as a *current divider*. Notice that the larger current flows through the smaller resistance.

As an extreme case, suppose one of the resistors in Fig. 2.31 is zero, say $R_2 = 0$; that is, R_2 is a short circuit, as shown in Fig. 2.33(a). From Eq. (2.43), $R_2 = 0$ implies that $i_1 = 0$, $i_2 = i$. This means that the entire current i bypasses R_1 and flows through the short circuit $R_2 = 0$, the path of least resistance. Thus when a circuit

is short circuited, as shown in Fig. 2.33(a), two things should be kept in mind:

1. The equivalent resistance $R_{\text{eq}} = 0$. [See what happens when $R_2 = 0$ in Eq. (2.37).]
2. The entire current flows through the short circuit.

As another extreme case, suppose $R_2 = \infty$, that is, R_2 is an open circuit, as shown in Fig. 2.33(b). The current still flows through the path of least resistance, R_1 . By taking the limit of Eq. (2.37) as $R_2 \rightarrow \infty$, we obtain $R_{\text{eq}} = R_1$ in this case.

If we divide both the numerator and denominator by $R_1 R_2$, Eq. (2.43) becomes

$$i_1 = \frac{G_1}{G_1 + G_2} i \quad (2.44a)$$

$$i_2 = \frac{G_2}{G_1 + G_2} i \quad (2.44b)$$

Thus, in general, if a current divider has N conductors (G_1, G_2, \dots, G_N) in parallel with the source current i , the n th conductor (G_n) will have current

$$i_n = \frac{G_n}{G_1 + G_2 + \dots + G_N} i \quad (2.45)$$

In general, it is often convenient and possible to combine resistors in series and parallel and reduce a resistive network to a single *equivalent resistance* R_{eq} . Such an equivalent resistance is the resistance between the designated terminals of the network and must exhibit the same i - v characteristics as the original network at the terminals.

Find R_{eq} for the circuit shown in Fig. 2.34.

Example 2.9

Solution:

To get R_{eq} , we combine resistors in series and in parallel. The 6- Ω and 3- Ω resistors are in parallel, so their equivalent resistance is

$$6 \Omega \parallel 3 \Omega = \frac{6 \times 3}{6 + 3} = 2 \Omega$$

(The symbol \parallel is used to indicate a parallel combination.) Also, the 1- Ω and 5- Ω resistors are in series; hence their equivalent resistance is

$$1 \Omega + 5 \Omega = 6 \Omega$$

Thus the circuit in Fig. 2.34 is reduced to that in Fig. 2.35(a). In Fig. 2.35(a), we notice that the two 2- Ω resistors are in series, so the equivalent resistance is

$$2 \Omega + 2 \Omega = 4 \Omega$$

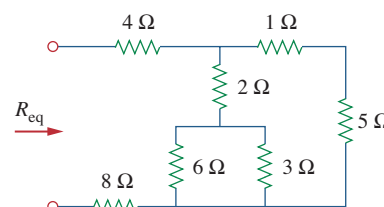

Figure 2.34
For Example 2.9.

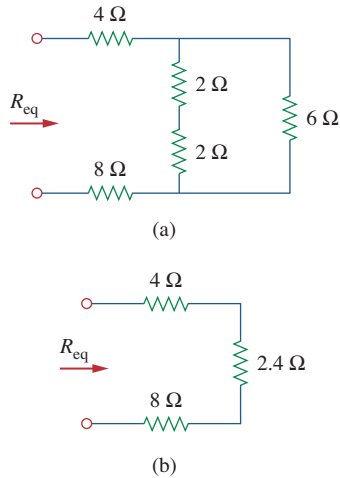

Figure 2.35
Equivalent circuits for Example 2.9.

This 4-Ω resistor is now in parallel with the 6-Ω resistor in Fig. 2.35(a); their equivalent resistance is

$$4 \Omega \parallel 6 \Omega = \frac{4 \times 6}{4 + 6} = 2.4 \Omega$$

The circuit in Fig. 2.35(a) is now replaced with that in Fig. 2.35(b). In Fig. 2.35(b), the three resistors are in series. Hence, the equivalent resistance for the circuit is

$$R_{\text{eq}} = 4 \Omega + 2.4 \Omega + 8 \Omega = 14.4 \Omega$$

Practice Problem 2.9

By combining the resistors in Fig. 2.36, find R_{eq} .

Answer: 10 Ω.

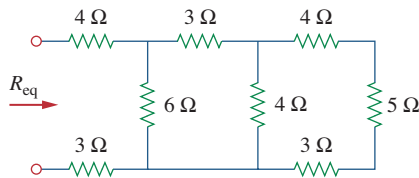

Figure 2.36
For Practice Prob. 2.9.

Example 2.10

Calculate the equivalent resistance R_{ab} in the circuit in Fig. 2.37.

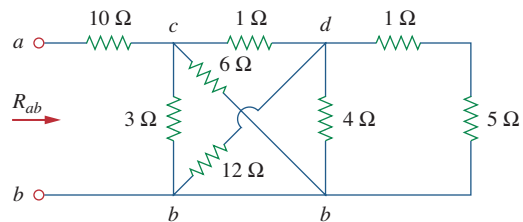

Figure 2.37
For Example 2.10.

Solution:

The 3-Ω and 6-Ω resistors are in parallel because they are connected to the same two nodes c and b . Their combined resistance is

$$3 \Omega \parallel 6 \Omega = \frac{3 \times 6}{3 + 6} = 2 \Omega \quad (2.10.1)$$

Similarly, the 12- Ω and 4- Ω resistors are in parallel since they are connected to the same two nodes d and b . Hence

$$12\ \Omega \parallel 4\ \Omega = \frac{12 \times 4}{12 + 4} = 3\ \Omega \quad (2.10.2)$$

Also the 1- Ω and 5- Ω resistors are in series; hence, their equivalent resistance is

$$1\ \Omega + 5\ \Omega = 6\ \Omega \quad (2.10.3)$$

With these three combinations, we can replace the circuit in Fig. 2.37 with that in Fig. 2.38(a). In Fig. 2.38(a), 3- Ω in parallel with 6- Ω gives 2- Ω , as calculated in Eq. (2.10.1). This 2- Ω equivalent resistance is now in series with the 1- Ω resistance to give a combined resistance of $1\ \Omega + 2\ \Omega = 3\ \Omega$. Thus, we replace the circuit in Fig. 2.38(a) with that in Fig. 2.38(b). In Fig. 2.38(b), we combine the 2- Ω and 3- Ω resistors in parallel to get

$$2\ \Omega \parallel 3\ \Omega = \frac{2 \times 3}{2 + 3} = 1.2\ \Omega$$

This 1.2- Ω resistor is in series with the 10- Ω resistor, so that

$$R_{ab} = 10 + 1.2 = 11.2\ \Omega$$

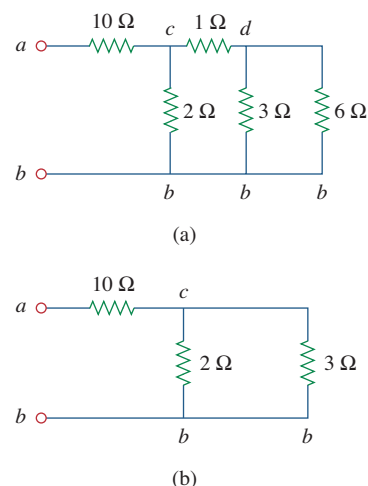

Figure 2.38
Equivalent circuits for Example 2.10.

Find R_{ab} for the circuit in Fig. 2.39.

Answer: 19 Ω .

Practice Problem 2.10

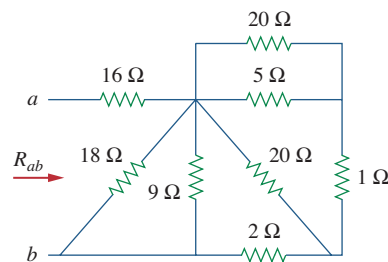

Figure 2.39
For Practice Prob. 2.10.

Find the equivalent conductance G_{eq} for the circuit in Fig. 2.40(a).

Example 2.11

Solution:

The 8-S and 12-S resistors are in parallel, so their conductance is

$$8\ \text{S} + 12\ \text{S} = 20\ \text{S}$$

This 20-S resistor is now in series with 5 S as shown in Fig. 2.40(b) so that the combined conductance is

$$\frac{20 \times 5}{20 + 5} = 4\ \text{S}$$

This is in parallel with the 6-S resistor. Hence,

$$G_{eq} = 6 + 4 = 10\ \text{S}$$

We should note that the circuit in Fig. 2.40(a) is the same as that in Fig. 2.40(c). While the resistors in Fig. 2.40(a) are expressed in

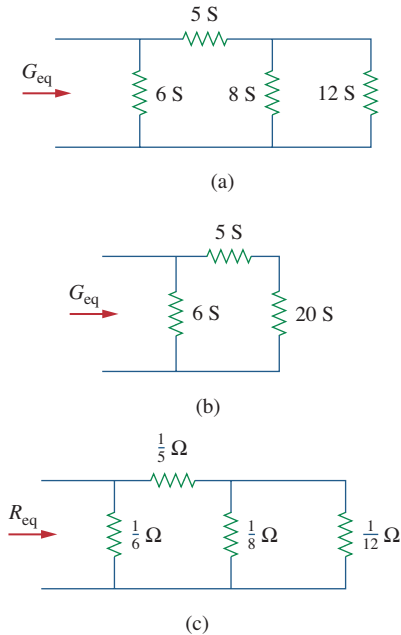
**Figure 2.40**

For Example 2.11: (a) original circuit, (b) its equivalent circuit, (c) same circuit as in (a) but resistors are expressed in ohms.

siemens, those in Fig. 2.40(c) are expressed in ohms. To show that the circuits are the same, we find R_{eq} for the circuit in Fig. 2.40(c).

$$R_{eq} = \frac{1}{6} \parallel \left(\frac{1}{5} + \frac{1}{8} \parallel \frac{1}{12} \right) = \frac{1}{6} \parallel \left(\frac{1}{5} + \frac{1}{20} \right) = \frac{1}{6} \parallel \frac{1}{4}$$

$$= \frac{\frac{1}{6} \times \frac{1}{4}}{\frac{1}{6} + \frac{1}{4}} = \frac{1}{10} \Omega$$

$$G_{eq} = \frac{1}{R_{eq}} = 10\text{ S}$$

This is the same as we obtained previously.

Practice Problem 2.11

Calculate G_{eq} in the circuit of Fig. 2.41.

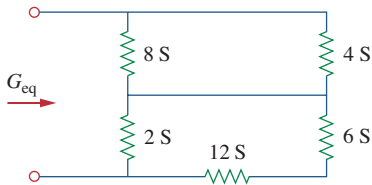
**Figure 2.41**

For Practice Prob. 2.11.

Answer: 4 S.

Example 2.12

Find i_o and v_o in the circuit shown in Fig. 2.42(a). Calculate the power dissipated in the $3\text{-}\Omega$ resistor.

Solution:

The $6\text{-}\Omega$ and $3\text{-}\Omega$ resistors are in parallel, so their combined resistance is

$$6\ \Omega \parallel 3\ \Omega = \frac{6 \times 3}{6 + 3} = 2\ \Omega$$

Thus our circuit reduces to that shown in Fig. 2.42(b). Notice that v_o is not affected by the combination of the resistors because the resistors are in parallel and therefore have the same voltage v_o . From Fig. 2.42(b), we can obtain v_o in two ways. One way is to apply Ohm's law to get

$$i = \frac{12}{4 + 2} = 2\text{ A}$$

and hence, $v_o = 2i = 2 \times 2 = 4$ V. Another way is to apply voltage division, since the 12 V in Fig. 2.42(b) is divided between the 4- Ω and 2- Ω resistors. Hence,

$$v_o = \frac{2}{2 + 4} (12 \text{ V}) = 4 \text{ V}$$

Similarly, i_o can be obtained in two ways. One approach is to apply Ohm's law to the 3- Ω resistor in Fig. 2.42(a) now that we know v_o ; thus,

$$v_o = 3i_o = 4 \quad \Rightarrow \quad i_o = \frac{4}{3} \text{ A}$$

Another approach is to apply current division to the circuit in Fig. 2.42(a) now that we know i , by writing

$$i_o = \frac{6}{6 + 3} i = \frac{2}{3} (2 \text{ A}) = \frac{4}{3} \text{ A}$$

The power dissipated in the 3- Ω resistor is

$$p_o = v_o i_o = 4 \left(\frac{4}{3} \right) = 5.333 \text{ W}$$

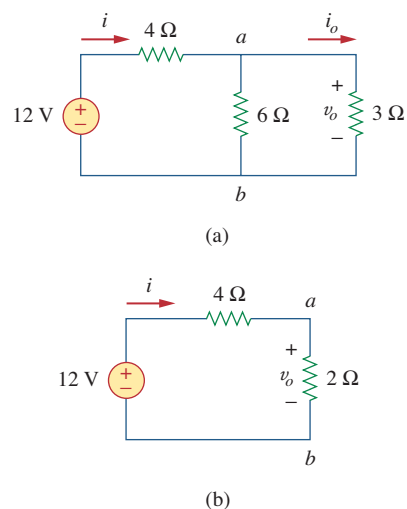

Figure 2.42

For Example 2.12: (a) original circuit, (b) its equivalent circuit.

Find v_1 and v_2 in the circuit shown in Fig. 2.43. Also calculate i_1 and i_2 and the power dissipated in the 12- Ω and 40- Ω resistors.

Answer: $v_1 = 10$ V, $i_1 = 833.3$ mA, $p_1 = 8.333$ W, $v_2 = 20$ V, $i_2 = 500$ mA, $p_2 = 10$ W.

Practice Problem 2.12

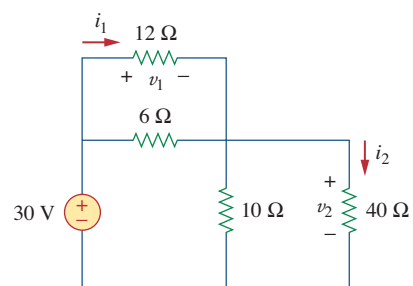

Figure 2.43

For Practice Prob. 2.12.

For the circuit shown in Fig. 2.44(a), determine: (a) the voltage v_o , (b) the power supplied by the current source, (c) the power absorbed by each resistor.

Solution:

(a) The 6-k Ω and 12-k Ω resistors are in series so that their combined value is $6 + 12 = 18$ k Ω . Thus the circuit in Fig. 2.44(a) reduces to that shown in Fig. 2.44(b). We now apply the current division technique to find i_1 and i_2 .

$$i_1 = \frac{18,000}{9,000 + 18,000} (30 \text{ mA}) = 20 \text{ mA}$$

$$i_2 = \frac{9,000}{9,000 + 18,000} (30 \text{ mA}) = 10 \text{ mA}$$

Example 2.13

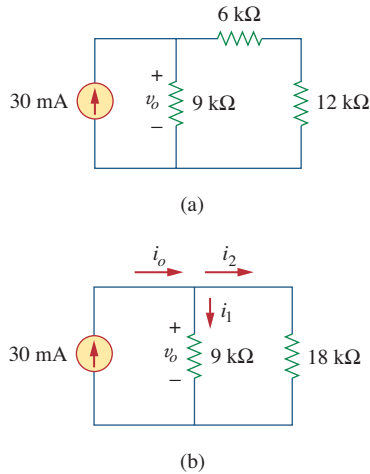
**Figure 2.44**

For Example 2.13: (a) original circuit, (b) its equivalent circuit.

Notice that the voltage across the 9-k Ω and 18-k Ω resistors is the same, and $v_o = 9,000i_1 = 18,000i_2 = 180$ V, as expected.

(b) Power supplied by the source is

$$p_o = v_o i_o = 180(30) \text{ mW} = 5.4 \text{ W}$$

(c) Power absorbed by the 12-k Ω resistor is

$$p = iv = i_2(i_2 R) = i_2^2 R = (10 \times 10^{-3})^2 (12,000) = 1.2 \text{ W}$$

Power absorbed by the 6-k Ω resistor is

$$p = i_2^2 R = (10 \times 10^{-3})^2 (6,000) = 0.6 \text{ W}$$

Power absorbed by the 9-k Ω resistor is

$$p = \frac{v_o^2}{R} = \frac{(180)^2}{9,000} = 3.6 \text{ W}$$

or

$$p = v_o i_1 = 180(20) \text{ mW} = 3.6 \text{ W}$$

Notice that the power supplied (5.4 W) equals the power absorbed ($1.2 + 0.6 + 3.6 = 5.4$ W). This is one way of checking results.

Practice Problem 2.13

For the circuit shown in Fig. 2.45, find: (a) v_1 and v_2 , (b) the power dissipated in the 3-k Ω and 20-k Ω resistors, and (c) the power supplied by the current source.

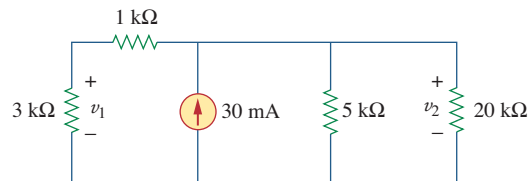
**Figure 2.45**

For Practice Prob. 2.13.

Answer: (a) 45 V, 60 V, (b) 675 mW, 180 mW, (c) 1.8 W.

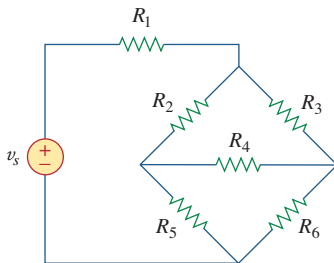
**Figure 2.46**

The bridge network.

2.7 † Wye-Delta Transformations

Situations often arise in circuit analysis when the resistors are neither in parallel nor in series. For example, consider the bridge circuit in Fig. 2.46. How do we combine resistors R_1 through R_6 when the resistors are neither in series nor in parallel? Many circuits of the type shown in Fig. 2.46 can be simplified by using three-terminal equivalent networks. These are

the wye (Y) or tee (T) network shown in Fig. 2.47 and the delta (Δ) or pi (Π) network shown in Fig. 2.48. These networks occur by themselves or as part of a larger network. They are used in three-phase networks, electrical filters, and matching networks. Our main interest here is in how to identify them when they occur as part of a network and how to apply wye-delta transformation in the analysis of that network.

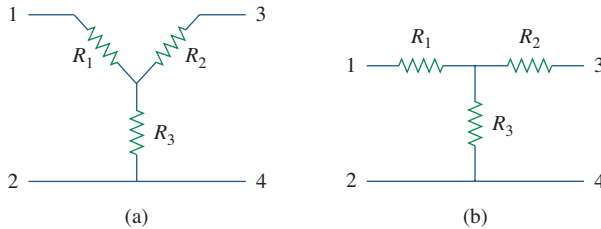

Figure 2.47

Two forms of the same network: (a) Y, (b) T.

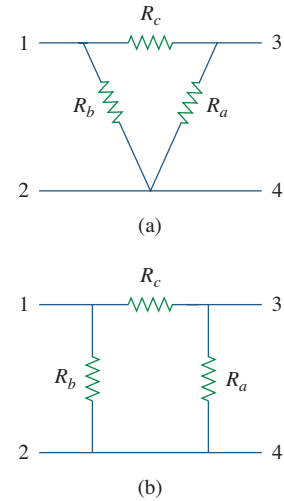

Figure 2.48

Two forms of the same network: (a) Δ , (b) Π .

Delta to Wye Conversion

Suppose it is more convenient to work with a wye network in a place where the circuit contains a delta configuration. We superimpose a wye network on the existing delta network and find the equivalent resistances in the wye network. To obtain the equivalent resistances in the wye network, we compare the two networks and make sure that the resistance between each pair of nodes in the Δ (or Π) network is the same as the resistance between the same pair of nodes in the Y (or T) network. For terminals 1 and 2 in Figs. 2.47 and 2.48, for example,

$$R_{12}(\text{Y}) = R_1 + R_3 \quad (2.46)$$

$$R_{12}(\Delta) = R_b \parallel (R_a + R_c)$$

Setting $R_{12}(\text{Y}) = R_{12}(\Delta)$ gives

$$R_{12} = R_1 + R_3 = \frac{R_b(R_a + R_c)}{R_a + R_b + R_c} \quad (2.47a)$$

Similarly,

$$R_{13} = R_1 + R_2 = \frac{R_c(R_a + R_b)}{R_a + R_b + R_c} \quad (2.47b)$$

$$R_{34} = R_2 + R_3 = \frac{R_a(R_b + R_c)}{R_a + R_b + R_c} \quad (2.47c)$$

Subtracting Eq. (2.47c) from Eq. (2.47a), we get

$$R_1 - R_2 = \frac{R_c(R_b - R_a)}{R_a + R_b + R_c} \quad (2.48)$$

Adding Eqs. (2.47b) and (2.48) gives

$$R_1 = \frac{R_b R_c}{R_a + R_b + R_c} \quad (2.49)$$

and subtracting Eq. (2.48) from Eq. (2.47b) yields

$$R_2 = \frac{R_c R_a}{R_a + R_b + R_c} \quad (2.50)$$

Subtracting Eq. (2.49) from Eq. (2.47a), we obtain

$$R_3 = \frac{R_a R_b}{R_a + R_b + R_c} \quad (2.51)$$

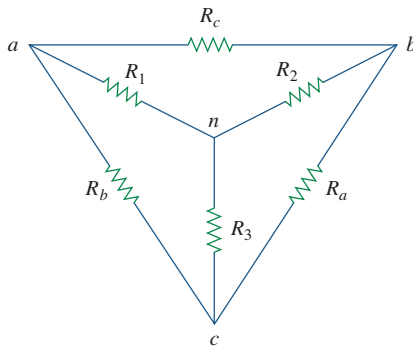

Figure 2.49

Superposition of Y and Δ networks as an aid in transforming one to the other.

We do not need to memorize Eqs. (2.49) to (2.51). To transform a Δ network to Y, we create an extra node n as shown in Fig. 2.49 and follow this conversion rule:

Each resistor in the Y network is the product of the resistors in the two adjacent Δ branches, divided by the sum of the three Δ resistors.

One can follow this rule and obtain Eqs. (2.49) to (2.51) from Fig. 2.49.

Wye to Delta Conversion

To obtain the conversion formulas for transforming a wye network to an equivalent delta network, we note from Eqs. (2.49) to (2.51) that

$$\begin{aligned} R_1 R_2 + R_2 R_3 + R_3 R_1 &= \frac{R_a R_b R_c (R_a + R_b + R_c)}{(R_a + R_b + R_c)^2} \\ &= \frac{R_a R_b R_c}{R_a + R_b + R_c} \end{aligned} \quad (2.52)$$

Dividing Eq. (2.52) by each of Eqs. (2.49) to (2.51) leads to the following equations:

$$R_a = \frac{R_1 R_2 + R_2 R_3 + R_3 R_1}{R_1} \quad (2.53)$$

$$R_b = \frac{R_1 R_2 + R_2 R_3 + R_3 R_1}{R_2} \quad (2.54)$$

$$R_c = \frac{R_1 R_2 + R_2 R_3 + R_3 R_1}{R_3} \quad (2.55)$$

From Eqs. (2.53) to (2.55) and Fig. 2.49, the conversion rule for Y to Δ is as follows:

Each resistor in the Δ network is the sum of all possible products of Y resistors taken two at a time, divided by the opposite Y resistor.

The Y and Δ networks are said to be *balanced* when

$$R_1 = R_2 = R_3 = R_Y, \quad R_a = R_b = R_c = R_\Delta \quad (2.56)$$

Under these conditions, conversion formulas become

$$R_Y = \frac{R_\Delta}{3} \quad \text{or} \quad R_\Delta = 3R_Y \quad (2.57)$$

One may wonder why R_Y is less than R_Δ . Well, we notice that the Y-connection is like a “series” connection while the Δ -connection is like a “parallel” connection.

Note that in making the transformation, we do not take anything out of the circuit or put in anything new. We are merely substituting different but mathematically equivalent three-terminal network patterns to create a circuit in which resistors are either in series or in parallel, allowing us to calculate R_{eq} if necessary.

Convert the Δ network in Fig. 2.50(a) to an equivalent Y network.

Example 2.14

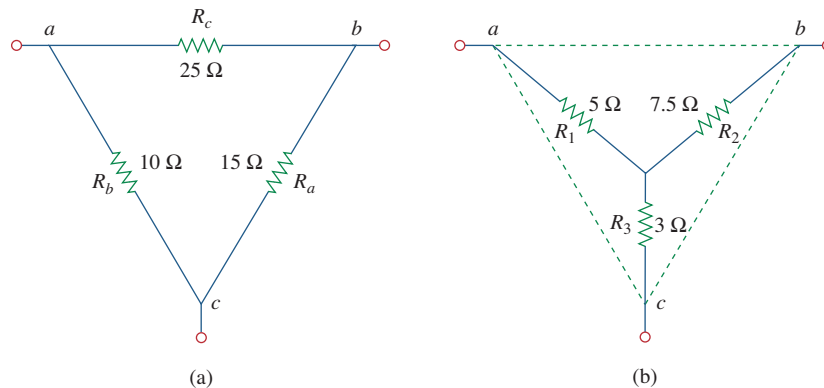

Figure 2.50

For Example 2.14: (a) original Δ network, (b) Y equivalent network.

Solution:

Using Eqs. (2.49) to (2.51), we obtain

$$R_1 = \frac{R_b R_c}{R_a + R_b + R_c} = \frac{10 \times 25}{15 + 10 + 25} = \frac{250}{50} = 5 \Omega$$

$$R_2 = \frac{R_c R_a}{R_a + R_b + R_c} = \frac{25 \times 15}{50} = 7.5 \Omega$$

$$R_3 = \frac{R_a R_b}{R_a + R_b + R_c} = \frac{15 \times 10}{50} = 3 \Omega$$

The equivalent Y network is shown in Fig. 2.50(b).

Practice Problem 2.14

Transform the wye network in Fig. 2.51 to a delta network.

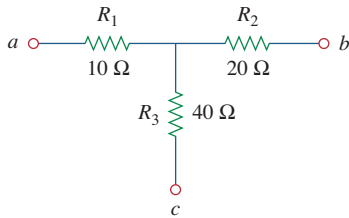

Answer: $R_a = 140 \Omega$, $R_b = 70 \Omega$, $R_c = 35 \Omega$.

Figure 2.51

For Practice Prob. 2.14.

Example 2.15

Obtain the equivalent resistance R_{ab} for the circuit in Fig. 2.52 and use it to find current i .

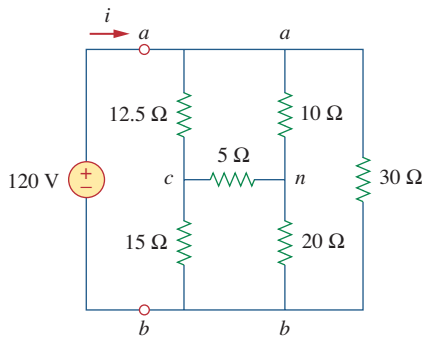

Figure 2.52

For Example 2.15.

Solution:

- Define.** The problem is clearly defined. Please note, this part normally will deservedly take much more time.
- Present.** Clearly, when we remove the voltage source, we end up with a purely resistive circuit. Since it is composed of deltas and wyes, we have a more complex process of combining the elements together. We can use wye-delta transformations as one approach to find a solution. It is useful to locate the wyes (there are two of them, one at n and the other at c) and the deltas (there are three: can , abn , cnb).
- Alternative.** There are different approaches that can be used to solve this problem. Since the focus of Sec. 2.7 is the wye-delta transformation, this should be the technique to use. Another approach would be to solve for the equivalent resistance by injecting one amp into the circuit and finding the voltage between a and b ; we will learn about this approach in Chap. 4.

The approach we can apply here as a check would be to use a wye-delta transformation as the first solution to the problem. Later we can check the solution by starting with a delta-wye transformation.

- Attempt.** In this circuit, there are two Y networks and three Δ networks. Transforming just one of these will simplify the circuit. If we convert the Y network comprising the 5- Ω , 10- Ω , and 20- Ω resistors, we may select

$$R_1 = 10 \Omega, \quad R_2 = 20 \Omega, \quad R_3 = 5 \Omega$$

Thus from Eqs. (2.53) to (2.55) we have

$$R_a = \frac{R_1 R_2 + R_2 R_3 + R_3 R_1}{R_1} = \frac{10 \times 20 + 20 \times 5 + 5 \times 10}{10}$$

$$= \frac{350}{10} = 35 \Omega$$

$$R_b = \frac{R_1 R_2 + R_2 R_3 + R_3 R_1}{R_2} = \frac{350}{20} = 17.5 \Omega$$

$$R_c = \frac{R_1 R_2 + R_2 R_3 + R_3 R_1}{R_3} = \frac{350}{5} = 70 \Omega$$

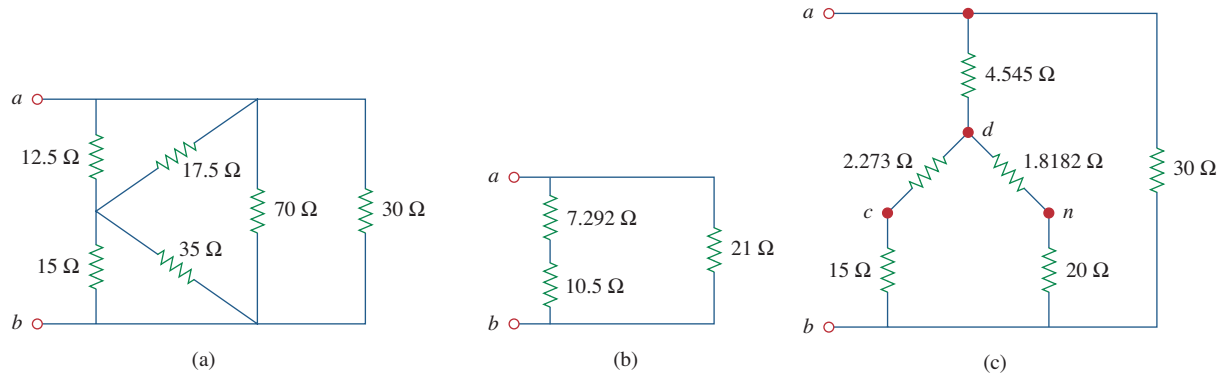
**Figure 2.53**

Equivalent circuits to Fig. 2.52, with the voltage source removed.

With the Y converted to Δ , the equivalent circuit (with the voltage source removed for now) is shown in Fig. 2.53(a). Combining the three pairs of resistors in parallel, we obtain

$$70 \parallel 30 = \frac{70 \times 30}{70 + 30} = 21 \Omega$$

$$12.5 \parallel 17.5 = \frac{12.5 \times 17.5}{12.5 + 17.5} = 7.292 \Omega$$

$$15 \parallel 35 = \frac{15 \times 35}{15 + 35} = 10.5 \Omega$$

so that the equivalent circuit is shown in Fig. 2.53(b). Hence, we find

$$R_{ab} = (7.292 + 10.5) \parallel 21 = \frac{17.792 \times 21}{17.792 + 21} = \mathbf{9.632 \Omega}$$

Then

$$i = \frac{v_s}{R_{ab}} = \frac{120}{9.632} = \mathbf{12.458 \text{ A}}$$

We observe that we have successfully solved the problem. Now we must evaluate the solution.

5. **Evaluate.** Now we must determine if the answer is correct and then evaluate the final solution.

It is relatively easy to check the answer; we do this by solving the problem starting with a delta-wye transformation. Let us transform the delta, *can*, into a wye.

Let $R_c = 10 \Omega$, $R_a = 5 \Omega$, and $R_n = 12.5 \Omega$. This will lead to (let d represent the middle of the wye):

$$R_{ad} = \frac{R_c R_n}{R_a + R_c + R_n} = \frac{10 \times 12.5}{5 + 10 + 12.5} = 4.545 \Omega$$

$$R_{cd} = \frac{R_a R_n}{27.5} = \frac{5 \times 12.5}{27.5} = 2.273 \Omega$$

$$R_{nd} = \frac{R_a R_c}{27.5} = \frac{5 \times 10}{27.5} = 1.8182 \Omega$$

This now leads to the circuit shown in Figure 2.53(c). Looking at the resistance between d and b , we have two series combination in parallel, giving us

$$R_{db} = \frac{(2.273 + 15)(1.8182 + 20)}{2.273 + 15 + 1.8182 + 20} = \frac{376.9}{39.09} = 9.642 \Omega$$

This is in series with the 4.545- Ω resistor, both of which are in parallel with the 30- Ω resistor. This then gives us the equivalent resistance of the circuit.

$$R_{ab} = \frac{(9.642 + 4.545)30}{9.642 + 4.545 + 30} = \frac{425.6}{44.19} = \mathbf{9.631 \Omega}$$

This now leads to

$$i = \frac{v_s}{R_{ab}} = \frac{120}{9.631} = \mathbf{12.46 \text{ A}}$$

We note that using two variations on the wye-delta transformation leads to the same results. This represents a very good check.

6. **Satisfactory?** Since we have found the desired answer by determining the equivalent resistance of the circuit first and the answer checks, then we clearly have a satisfactory solution. This represents what can be presented to the individual assigning the problem.

Practice Problem 2.15

For the bridge network in Fig. 2.54, find R_{ab} and i .

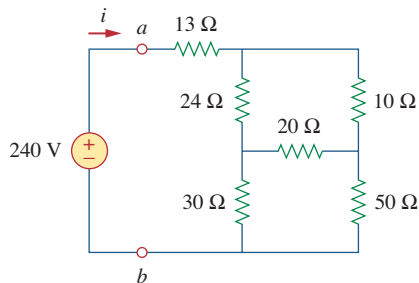

Figure 2.54

For Practice Prob. 2.15.

Answer: 40 Ω , 6 A.

2.8 Applications

Resistors are often used to model devices that convert electrical energy into heat or other forms of energy. Such devices include conducting wire, light bulbs, electric heaters, stoves, ovens, and loudspeakers. In this section, we will consider two real-life problems that apply the concepts developed in this chapter: electrical lighting systems and design of dc meters.

2.8.1 Lighting Systems

Lighting systems, such as in a house or on a Christmas tree, often consist of N lamps connected either in parallel or in series, as shown in Fig. 2.55. Each lamp is modeled as a resistor. Assuming that all the lamps are identical and V_o is the power-line voltage, the voltage across each lamp is V_o for the parallel connection and V_o/N for the series connection. The series connection is easy to manufacture but is seldom used in practice, for at least two reasons. First, it is less reliable; when a lamp fails, all the lamps go out. Second, it is harder to maintain; when a lamp is bad, one must test all the lamps one by one to detect the faulty one.

So far, we have assumed that connecting wires are perfect conductors (i.e., conductors of zero resistance). In real physical systems, however, the resistance of the connecting wire may be appreciably large, and the modeling of the system must include that resistance.

Historical

Thomas Alva Edison (1847–1931) was perhaps the greatest American inventor. He patented 1093 inventions, including such history-making inventions as the incandescent electric bulb, the phonograph, and the first commercial motion pictures.

Born in Milan, Ohio, the youngest of seven children, Edison received only three months of formal education because he hated school. He was home-schooled by his mother and quickly began to read on his own. In 1868, Edison read one of Faraday's books and found his calling. He moved to Menlo Park, New Jersey, in 1876, where he managed a well-staffed research laboratory. Most of his inventions came out of this laboratory. His laboratory served as a model for modern research organizations. Because of his diverse interests and the overwhelming number of his inventions and patents, Edison began to establish manufacturing companies for making the devices he invented. He designed the first electric power station to supply electric light. Formal electrical engineering education began in the mid-1880s with Edison as a role model and leader.

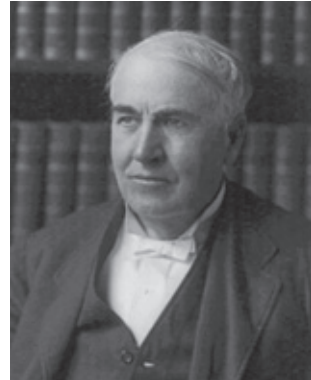

Library of Congress

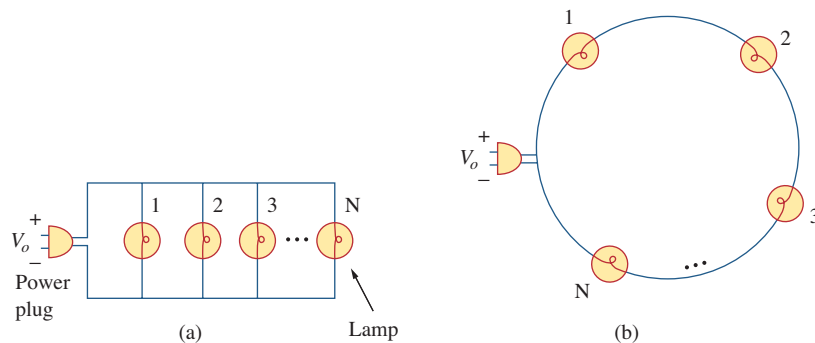

Figure 2.55

(a) Parallel connection of light bulbs, (b) series connection of light bulbs.

Three light bulbs are connected to a 9-V battery as shown in Fig. 2.56(a). Calculate: (a) the total current supplied by the battery, (b) the current through each bulb, (c) the resistance of each bulb.

Example 2.16

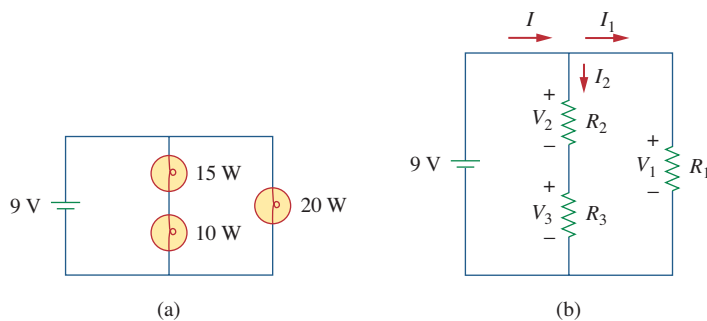

Figure 2.56

(a) Lighting system with three bulbs, (b) resistive circuit equivalent model.

Solution:

(a) The total power supplied by the battery is equal to the total power absorbed by the bulbs; that is,

$$p = 15 + 10 + 20 = 45 \text{ W}$$

Since $p = VI$, then the total current supplied by the battery is

$$I = \frac{p}{V} = \frac{45}{9} = 5 \text{ A}$$

(b) The bulbs can be modeled as resistors as shown in Fig. 2.56(b). Since R_1 (20-W bulb) is in parallel with the battery as well as the series combination of R_2 and R_3 ,

$$V_1 = V_2 + V_3 = 9 \text{ V}$$

The current through R_1 is

$$I_1 = \frac{p_1}{V_1} = \frac{20}{9} = 2.222 \text{ A}$$

By KCL, the current through the series combination of R_2 and R_3 is

$$I_2 = I - I_1 = 5 - 2.222 = 2.778 \text{ A}$$

(c) Since $p = I^2R$,

$$R_1 = \frac{p_1}{I_1^2} = \frac{20}{2.222^2} = 4.05 \ \Omega$$

$$R_2 = \frac{p_2}{I_2^2} = \frac{15}{2.777^2} = 1.945 \ \Omega$$

$$R_3 = \frac{p_3}{I_3^2} = \frac{10}{2.777^2} = 1.297 \ \Omega$$

Practice Problem 2.16

Refer to Fig. 2.55 and assume there are 10 light bulbs that can be connected in parallel and 10 light bulbs that can be connected in series, each with a power rating of 40 W. If the voltage at the plug is 110 V for the parallel and series connections, calculate the current through each bulb for both cases.

Answer: 364 mA (parallel), 3.64 A (series).

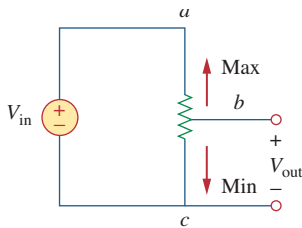

Figure 2.57

The potentiometer controlling potential levels.

2.8.2 Design of DC Meters

By their nature, resistors are used to control the flow of current. We take advantage of this property in several applications, such as in a potentiometer (Fig. 2.57). The word *potentiometer*, derived from the words *potential* and *meter*, implies that potential can be metered out. The potentiometer (or pot for short) is a three-terminal device that operates on the principle of voltage division. It is essentially an adjustable voltage divider. As a voltage regulator, it is used as a volume or level control on radios, TVs, and other devices. In Fig. 2.57,

$$V_{\text{out}} = V_{bc} = \frac{R_{bc}}{R_{ac}} V_{\text{in}} \quad (2.58)$$

where $R_{ac} = R_{ab} + R_{bc}$. Thus, V_{out} decreases or increases as the sliding contact of the pot moves toward c or a , respectively.

Another application where resistors are used to control current flow is in the analog dc meters—the ammeter, voltmeter, and ohmmeter, which measure current, voltage, and resistance, respectively. Each of these meters employs the d’Arsonval meter movement, shown in Fig. 2.58. The movement consists essentially of a movable iron-core coil mounted on a pivot between the poles of a permanent magnet. When current flows through the coil, it creates a torque which causes the pointer to deflect. The amount of current through the coil determines the deflection of the pointer, which is registered on a scale attached to the meter movement. For example, if the meter movement is rated 1 mA, 50 Ω , it would take 1 mA to cause a full-scale deflection of the meter movement. By introducing additional circuitry to the d’Arsonval meter movement, an ammeter, voltmeter, or ohmmeter can be constructed.

Consider Fig. 2.59, where an analog voltmeter and ammeter are connected to an element. The voltmeter measures the voltage across a *load* and is therefore connected in parallel with the element. As shown

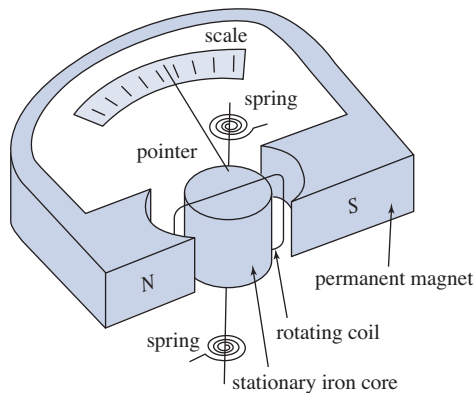

Figure 2.58
A d’Arsonval meter movement.

in Fig. 2.60(a), the voltmeter consists of a d’Arsonval movement in series with a resistor whose resistance R_m is deliberately made very large (theoretically, infinite), to minimize the current drawn from the circuit. To extend the range of voltage that the meter can measure, series multiplier resistors are often connected with the voltmeters, as shown in Fig. 2.60(b). The multiple-range voltmeter in Fig. 2.60(b) can measure voltage from 0 to 1 V, 0 to 10 V, or 0 to 100 V, depending on whether the switch is connected to R_1 , R_2 , or R_3 , respectively.

Let us calculate the multiplier resistor R_n for the single-range voltmeter in Fig. 2.60(a), or $R_n = R_1$, R_2 , or R_3 for the multiple-range voltmeter in Fig. 2.60(b). We need to determine the value of R_n to be connected in series with the internal resistance R_m of the voltmeter. In any design, we consider the worst-case condition. In this case, the worst case occurs when the full-scale current $I_{fs} = I_m$ flows through the meter. This should also correspond to the maximum voltage reading or the full-scale voltage V_{fs} . Since the multiplier resistance R_n is in series with the internal resistance R_m ,

$$V_{fs} = I_{fs}(R_n + R_m) \quad (2.59)$$

An instrument capable of measuring voltage, current, and resistance is called a *multimeter* or a *volt-ohm meter* (VOM).

A load is a component that is receiving energy (an energy sink), as opposed to a generator supplying energy (an energy source). More about loading will be discussed in Section 4.9.1.

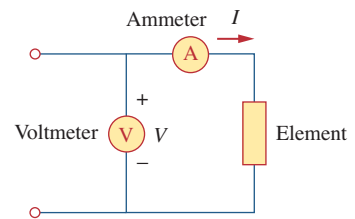

Figure 2.59
Connection of a voltmeter and an ammeter to an element.

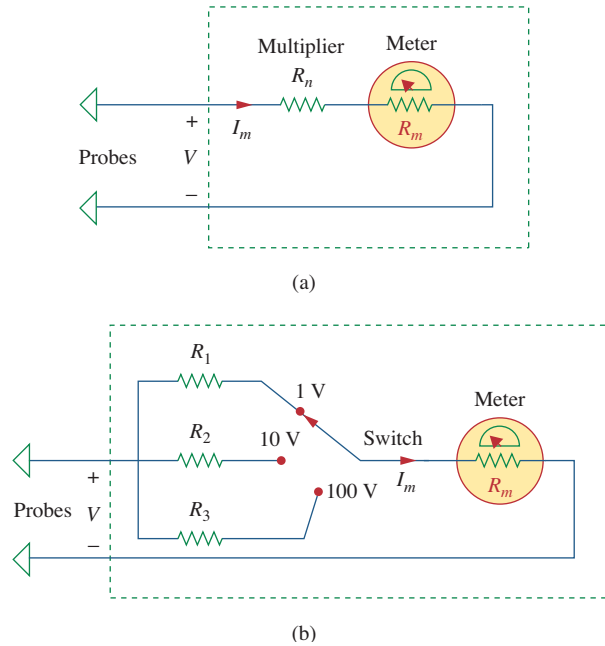

Figure 2.60 Voltmeters: (a) single-range type, (b) multiple-range type.

From this, we obtain

$$R_n = \frac{V_{fs}}{I_{fs}} - R_m \tag{2.60}$$

Similarly, the ammeter measures the current through the load and is connected in series with it. As shown in Fig. 2.61(a), the ammeter consists of a d’Arsonval movement in parallel with a resistor whose resistance R_m is deliberately made very small (theoretically, zero) to minimize the voltage drop across it. To allow multiple ranges, shunt resistors are often connected in parallel with R_m as shown in Fig. 2.61(b). The shunt resistors allow the meter to measure in the range 0–10 mA, 0–100 mA, or 0–1 A, depending on whether the switch is connected to R_1 , R_2 , or R_3 , respectively.

Now our objective is to obtain the multiplier shunt R_n for the single-range ammeter in Fig. 2.61(a), or $R_n = R_1, R_2$, or R_3 for the multiple-range ammeter in Fig. 2.61(b). We notice that R_m and R_n are in parallel and that at full-scale reading $I = I_{fs} = I_m + I_n$, where I_n is the current through the shunt resistor R_n . Applying the current division principle yields

$$I_m = \frac{R_n}{R_n + R_m} I_{fs}$$

or

$$R_n = \frac{I_m}{I_{fs} - I_m} R_m \tag{2.61}$$

The resistance R_x of a linear resistor can be measured in two ways. An indirect way is to measure the current I that flows through it by

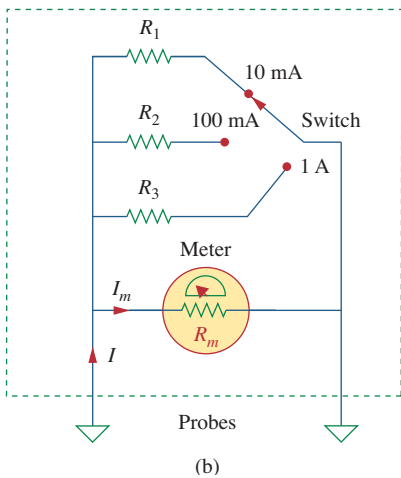
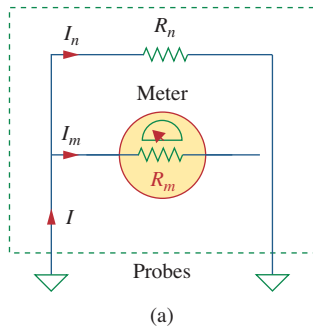

Figure 2.61 Ammeters: (a) single-range type, (b) multiple-range type.

connecting an ammeter in series with it and the voltage V across it by connecting a voltmeter in parallel with it, as shown in Fig. 2.62(a). Then

$$R_x = \frac{V}{I} \quad (2.62)$$

The direct method of measuring resistance is to use an ohmmeter. An ohmmeter consists basically of a d'Arsonval movement, a variable resistor or potentiometer, and a battery, as shown in Fig. 2.62(b). Applying KVL to the circuit in Fig. 2.62(b) gives

$$E = (R + R_m + R_x)I_m$$

or

$$R_x = \frac{E}{I_m} - (R + R_m) \quad (2.63)$$

The resistor R is selected such that the meter gives a full-scale deflection; that is, $I_m = I_{fs}$ when $R_x = 0$. This implies that

$$E = (R + R_m)I_{fs} \quad (2.64)$$

Substituting Eq. (2.64) into Eq. (2.63) leads to

$$R_x = \left(\frac{I_{fs}}{I_m} - 1 \right) (R + R_m) \quad (2.65)$$

As mentioned, the types of meters we have discussed are known as *analog* meters and are based on the d'Arsonval meter movement. Another type of meter, called a *digital meter*, is based on active circuit elements such as op amps. For example, a digital multimeter displays measurements of dc or ac voltage, current, and resistance as discrete numbers, instead of using a pointer deflection on a continuous scale as in an analog multimeter. Digital meters are what you would most likely use in a modern lab. However, the design of digital meters is beyond the scope of this book.

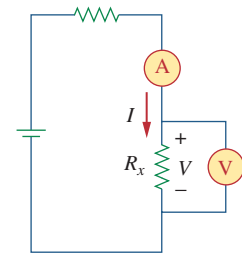

(a)

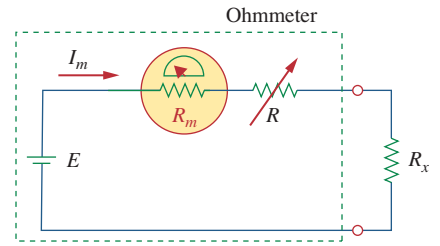

(b)

Figure 2.62

Two ways of measuring resistance:
(a) using an ammeter and a voltmeter,
(b) using an ohmmeter.

Historical

Samuel F. B. Morse (1791–1872), an American painter, invented the telegraph, the first practical, commercialized application of electricity.

Morse was born in Charlestown, Massachusetts and studied at Yale and the Royal Academy of Arts in London to become an artist. In the 1830s, he became intrigued with developing a telegraph. He had a working model by 1836 and applied for a patent in 1838. The U.S. Senate appropriated funds for Morse to construct a telegraph line between Baltimore and Washington, D.C. On May 24, 1844, he sent the famous first message: “What hath God wrought!” Morse also developed a code of dots and dashes for letters and numbers, for sending messages on the telegraph. The development of the telegraph led to the invention of the telephone.

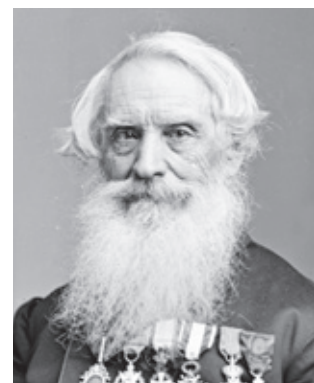

Library of Congress

Example 2.17

Following the voltmeter setup of Fig. 2.60, design a voltmeter for the following multiple ranges:

(a) 0–1 V (b) 0–5 V (c) 0–50 V (d) 0–100 V

Assume that the internal resistance $R_m = 2 \text{ k}\Omega$ and the full-scale current $I_{fs} = 100 \mu\text{A}$.

Solution:

We apply Eq. (2.60) and assume that $R_1, R_2, R_3,$ and R_4 correspond with ranges 0–1 V, 0–5 V, 0–50 V, and 0–100 V, respectively.

(a) For range 0–1 V,

$$R_1 = \frac{1}{100 \times 10^{-6}} - 2000 = 10,000 - 2000 = 8 \text{ k}\Omega$$

(b) For range 0–5 V,

$$R_2 = \frac{5}{100 \times 10^{-6}} - 2000 = 50,000 - 2000 = 48 \text{ k}\Omega$$

(c) For range 0–50 V,

$$R_3 = \frac{50}{100 \times 10^{-6}} - 2000 = 500,000 - 2000 = 498 \text{ k}\Omega$$

(d) For range 0–100 V,

$$R_4 = \frac{100 \text{ V}}{100 \times 10^{-6}} - 2000 = 1,000,000 - 2000 = 998 \text{ k}\Omega$$

Note that the ratio of the total resistance ($R_n + R_m$) to the full-scale voltage V_{fs} is constant and equal to $1/I_{fs}$ for the four ranges. This ratio (given in ohms per volt, or Ω/V) is known as the *sensitivity* of the voltmeter. The larger the sensitivity, the better the voltmeter.

Practice Problem 2.17

Following the ammeter setup of Fig. 2.61, design an ammeter for the following multiple ranges:

(a) 0–1 A (b) 0–100 mA (c) 0–10 mA

Take the full-scale meter current as $I_m = 1 \text{ mA}$ and the internal resistance of the ammeter as $R_m = 50 \Omega$.

Answer: Shunt resistors: 50 m Ω , 505 m Ω , 5.556 Ω .

2.9 Summary

1. A resistor is a passive element in which the voltage v across it is directly proportional to the current i through it. That is, a resistor is a device that obeys Ohm's law,

$$v = iR$$

where R is the resistance of the resistor.

2. A short circuit is a resistor (a perfectly, conducting wire) with zero resistance ($R = 0$). An open circuit is a resistor with infinite resistance ($R = \infty$).
3. The conductance G of a resistor is the reciprocal of its resistance:

$$G = \frac{1}{R}$$

4. A branch is a single two-terminal element in an electric circuit. A node is the point of connection between two or more branches. A loop is a closed path in a circuit. The number of branches b , the number of nodes n , and the number of independent loops l in a network are related as

$$b = l + n - 1$$

5. Kirchhoff's current law (KCL) states that the currents at any node algebraically sum to zero. In other words, the sum of the currents entering a node equals the sum of currents leaving the node.
6. Kirchhoff's voltage law (KVL) states that the voltages around a closed path algebraically sum to zero. In other words, the sum of voltage rises equals the sum of voltage drops.
7. Two elements are in series when they are connected sequentially, end to end. When elements are in series, the same current flows through them ($i_1 = i_2$). They are in parallel if they are connected to the same two nodes. Elements in parallel always have the same voltage across them ($v_1 = v_2$).
8. When two resistors $R_1 (=1/G_1)$ and $R_2 (=1/G_2)$ are in series, their equivalent resistance R_{eq} and equivalent conductance G_{eq} are

$$R_{\text{eq}} = R_1 + R_2, \quad G_{\text{eq}} = \frac{G_1 G_2}{G_1 + G_2}$$

9. When two resistors $R_1 (=1/G_1)$ and $R_2 (=1/G_2)$ are in parallel, their equivalent resistance R_{eq} and equivalent conductance G_{eq} are

$$R_{\text{eq}} = \frac{R_1 R_2}{R_1 + R_2}, \quad G_{\text{eq}} = G_1 + G_2$$

10. The voltage division principle for two resistors in series is

$$v_1 = \frac{R_1}{R_1 + R_2} v, \quad v_2 = \frac{R_2}{R_1 + R_2} v$$

11. The current division principle for two resistors in parallel is

$$i_1 = \frac{R_2}{R_1 + R_2} i, \quad i_2 = \frac{R_1}{R_1 + R_2} i$$

12. The formulas for a delta-to-ye transformation are

$$R_1 = \frac{R_b R_c}{R_a + R_b + R_c}, \quad R_2 = \frac{R_c R_a}{R_a + R_b + R_c}$$

$$R_3 = \frac{R_a R_b}{R_a + R_b + R_c}$$

13. The formulas for a wye-to-delta transformation are

$$R_a = \frac{R_1 R_2 + R_2 R_3 + R_3 R_1}{R_1}, \quad R_b = \frac{R_1 R_2 + R_2 R_3 + R_3 R_1}{R_2}$$

$$R_c = \frac{R_1 R_2 + R_2 R_3 + R_3 R_1}{R_3}$$

14. The basic laws covered in this chapter can be applied to the problems of electrical lighting and design of dc meters.

Review Questions

2.1 The reciprocal of resistance is:

- (a) voltage (b) current
(c) conductance (d) coulombs

2.2 An electric heater draws 10 A from a 120-V line. The resistance of the heater is:

- (a) 1200 Ω (b) 120 Ω
(c) 12 Ω (d) 1.2 Ω

2.3 The voltage drop across a 1.5-kW toaster that draws 12 A of current is:

- (a) 18 kV (b) 125 V
(c) 120 V (d) 10.42 V

2.4 The maximum current that a 2W, 80 k Ω resistor can safely conduct is:

- (a) 160 kA (b) 40 kA
(c) 5 mA (d) 25 μ A

2.5 A network has 12 branches and 8 independent loops. How many nodes are there in the network?

- (a) 19 (b) 17 (c) 5 (d) 4

2.6 The current I in the circuit of Fig. 2.63 is:

- (a) -0.8 A (b) -0.2 A
(c) 0.2 A (d) 0.8 A

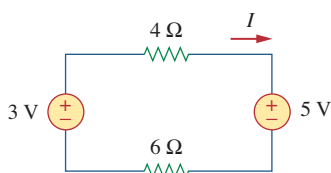

Figure 2.63

For Review Question 2.6.

2.7 The current I_o of Fig. 2.64 is:

- (a) -4 A (b) -2 A (c) 4 A (d) 16 A

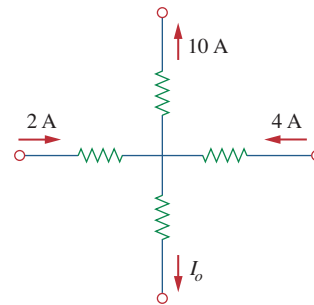

Figure 2.64

For Review Question 2.7.

2.8 In the circuit in Fig. 2.65, V is:

- (a) 30 V (b) 14 V (c) 10 V (d) 6 V

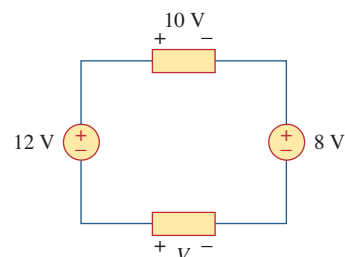

Figure 2.65

For Review Question 2.8.

- 2.9 Which of the circuits in Fig. 2.66 will give you $V_{ab} = 7\text{ V}$?

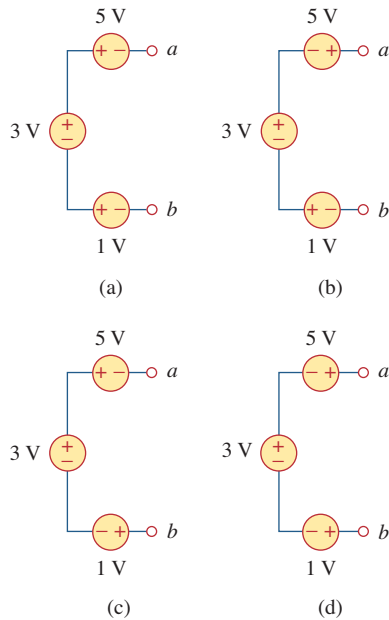

Figure 2.66
For Review Question 2.9.

- 2.10 In the circuit of Fig. 2.67, a decrease in R_3 leads to a decrease of, select all that apply:

- current through R_3
- voltage across R_3
- voltage across R_1
- power dissipated in R_2
- none of the above

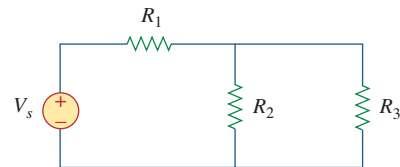

Figure 2.67
For Review Question 2.10.

Answers: 2.1c, 2.2c, 2.3b, 2.4c, 2.5c, 2.6b, 2.7a, 2.8d, 2.9d, 2.10b, d.

Problems

Section 2.2 Ohm's Law

- 2.1 **e7d** Design a problem, complete with a solution, to help students to better understand Ohm's Law. Use at least two resistors and one voltage source. Hint, you could use both resistors at once or one at a time, it is up to you. Be creative.
- 2.2 Find the hot resistance of a light bulb rated 60 W, 120 V.
- 2.3 A bar of silicon is 4 cm long with a circular cross section. If the resistance of the bar is $240\ \Omega$ at room temperature, what is the cross-sectional radius of the bar?
- 2.4 (a) Calculate current i in Fig. 2.68 when the switch is in position 1.
(b) Find the current when the switch is in position 2.

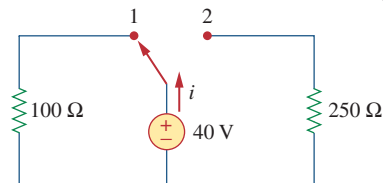

Figure 2.68
For Prob. 2.4.

Section 2.3 Nodes, Branches, and Loops

- 2.5 For the network graph in Fig. 2.69, find the number of nodes, branches, and loops.

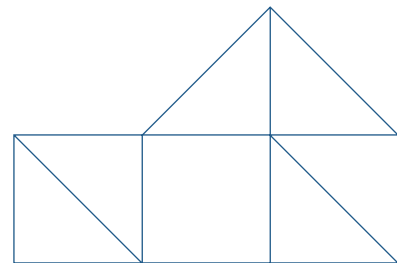

Figure 2.69
For Prob. 2.5.

- 2.6 In the network graph shown in Fig. 2.70, determine the number of branches and nodes.

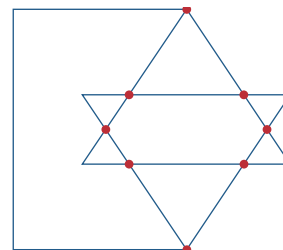

Figure 2.70
For Prob. 2.6.

- 2.7 Determine the number of branches and nodes in the circuit of Fig. 2.71.

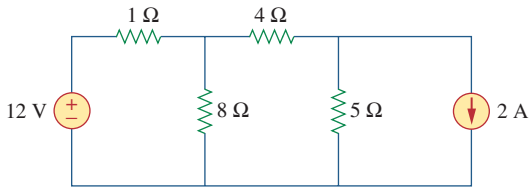

Figure 2.71

For Prob. 2.7.

Section 2.4 Kirchhoff's Laws

- 2.8 Design a problem, complete with a solution, to help other students better understand Kirchhoff's Current Law. Design the problem by specifying values of i_a , i_b , and i_c , shown in Fig. 2.72, and asking them to solve for values of i_1 , i_2 , and i_3 . Be careful to specify realistic currents.

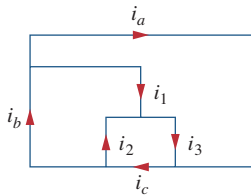

Figure 2.72

For Prob. 2.8.

- 2.9 Find i_1 , i_2 , and i_3 in Fig. 2.73.

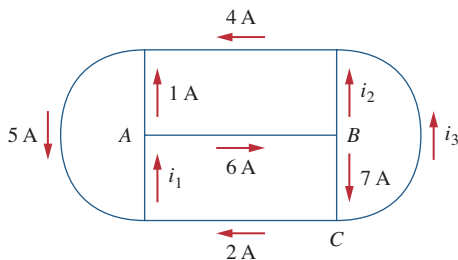

Figure 2.73

For Prob. 2.9.

- 2.10 Determine i_1 and i_2 in the circuit of Fig. 2.74.

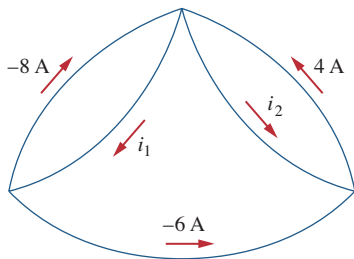

Figure 2.74

For Prob. 2.10.

- 2.11 In the circuit of Fig. 2.75, calculate V_1 and V_2 .

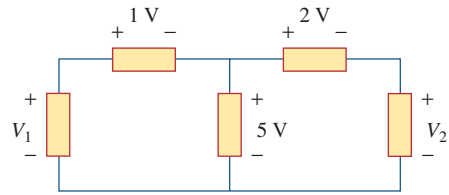

Figure 2.75

For Prob. 2.11.

- 2.12 In the circuit in Fig. 2.76, obtain v_1 , v_2 , and v_3 .

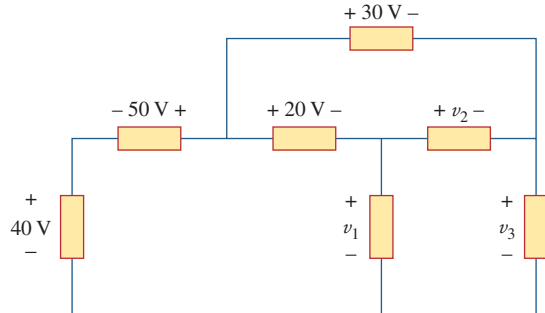

Figure 2.76

For Prob. 2.12.

- 2.13 For the circuit in Fig. 2.77, use KCL to find the branch currents I_1 to I_4 .

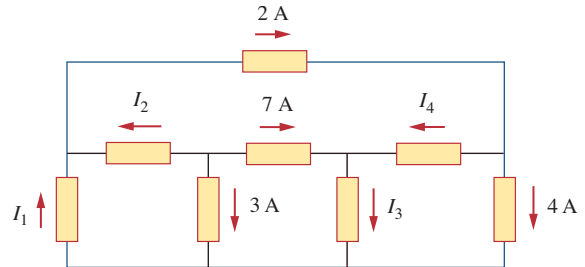

Figure 2.77

For Prob. 2.13.

- 2.14 Given the circuit in Fig. 2.78, use KVL to find the branch voltages V_1 to V_4 .

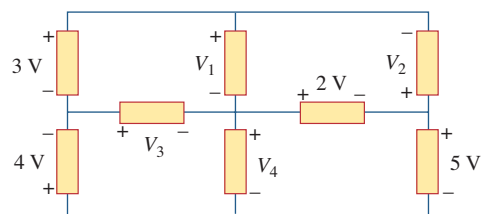

Figure 2.78

For Prob. 2.14.

2.15 Calculate v and i_x in the circuit of Fig. 2.79.

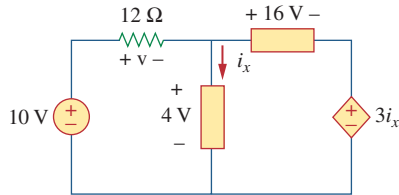

Figure 2.79
For Prob. 2.15.

2.16 Determine V_o in the circuit in Fig. 2.80.

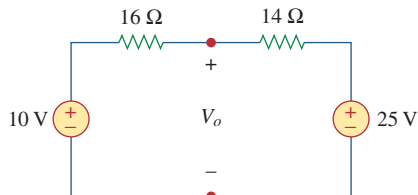

Figure 2.80
For Prob. 2.16.

2.17 Obtain v_1 through v_3 in the circuit of Fig. 2.81.

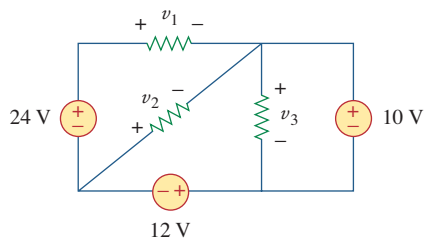

Figure 2.81
For Prob. 2.17.

2.18 Find I and V_{ab} in the circuit of Fig. 2.82.

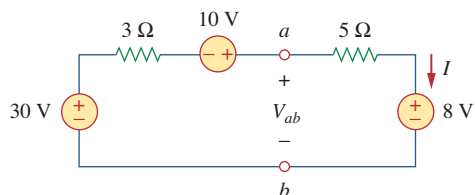

Figure 2.82
For Prob. 2.18.

2.19 From the circuit in Fig. 2.83, find I , the power dissipated by the resistor, and the power supplied by each source.

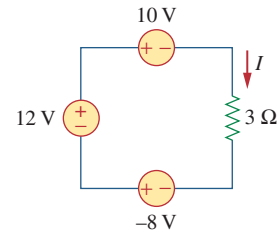

Figure 2.83
For Prob. 2.19.

2.20 Determine i_o in the circuit of Fig. 2.84.

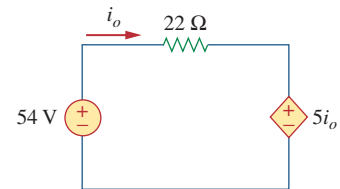

Figure 2.84
For Prob. 2.20.

2.21 Find V_x in the circuit of Fig. 2.85.

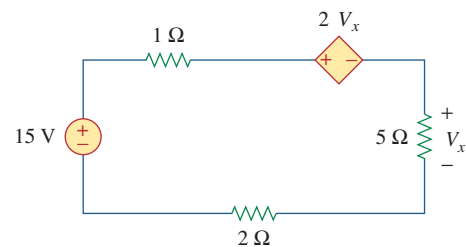

Figure 2.85
For Prob. 2.21.

2.22 Find V_o in the circuit in Fig. 2.86 and the power absorbed by the dependent source.

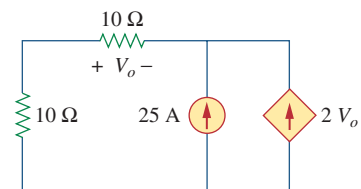

Figure 2.86
For Prob. 2.22.

- 2.23 In the circuit shown in Fig. 2.87, determine v_x and the power absorbed by the 12- Ω resistor.

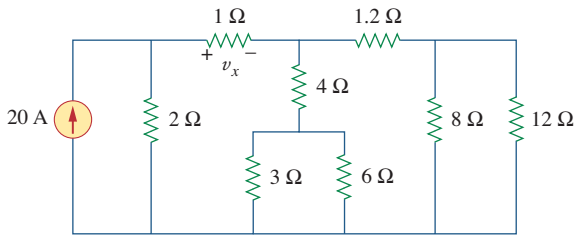

Figure 2.87

For Prob. 2.23.

- 2.24 For the circuit in Fig. 2.88, find V_o/V_s in terms of α , R_1 , R_2 , R_3 , and R_4 . If $R_1 = R_2 = R_3 = R_4$, what value of α will produce $|V_o/V_s| = 10$?

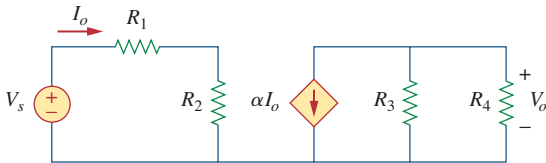

Figure 2.88

For Prob. 2.24.

- 2.25 For the network in Fig. 2.89, find the current, voltage, and power associated with the 20-k Ω resistor.

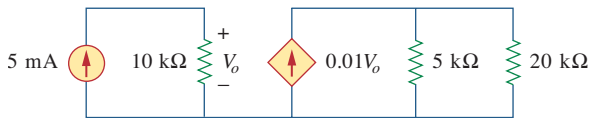

Figure 2.89

For Prob. 2.25.

Sections 2.5 and 2.6 Series and Parallel Resistors

- 2.26 For the circuit in Fig. 2.90, $i_o = 3$ A. Calculate i_x and the total power absorbed by the entire circuit.

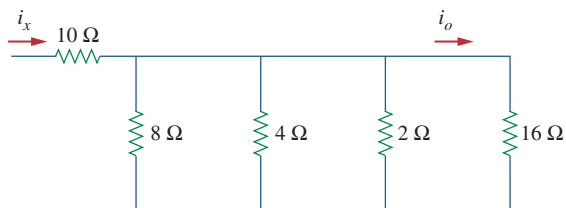

Figure 2.90

For Prob. 2.26.

- 2.27 Calculate I_o in the circuit of Fig. 2.91.

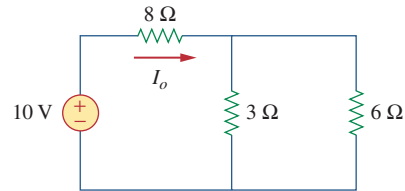

Figure 2.91

For Prob. 2.27.

- 2.28 Design a problem, using Fig. 2.92, to help other students better understand series and parallel circuits.

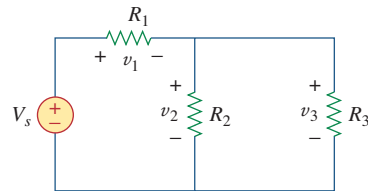

Figure 2.92

For Prob. 2.28.

- 2.29 All resistors in Fig. 2.93 are 5 Ω each. Find R_{eq} .

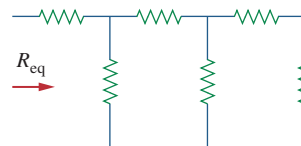

Figure 2.93

For Prob. 2.29.

- 2.30 Find R_{eq} for the circuit in Fig. 2.94.

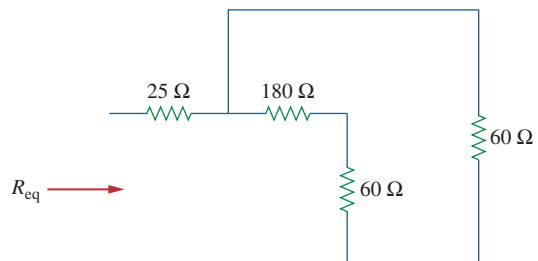

Figure 2.94

For Prob. 2.30.

2.31 For the circuit in Fig. 2.95, determine i_1 to i_5 .

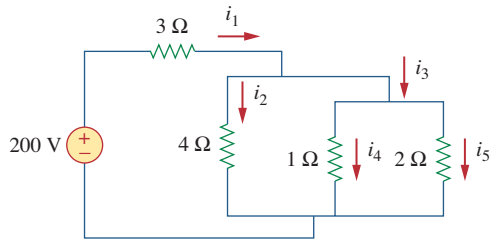

Figure 2.95
For Prob. 2.31.

2.32 Find i_1 through i_4 in the circuit in Fig. 2.96.

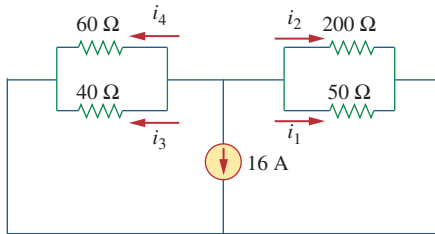

Figure 2.96
For Prob. 2.32.

2.33 Obtain v and i in the circuit of Fig. 2.97.

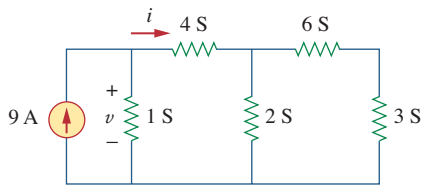

Figure 2.97
For Prob. 2.33.

2.34 Using series/parallel resistance combination, find the equivalent resistance seen by the source in the circuit of Fig. 2.98. Find the overall absorbed power by the resistor network.

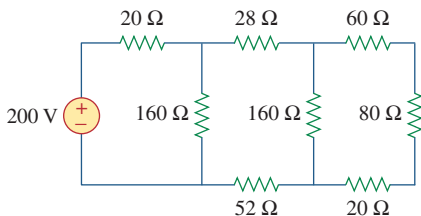

Figure 2.98
For Prob. 2.34.

2.35 Calculate V_o and I_o in the circuit of Fig. 2.99.

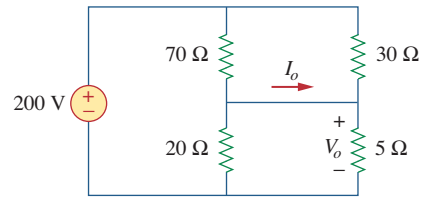

Figure 2.99
For Prob. 2.35.

2.36 Find i and V_o in the circuit of Fig. 2.100.

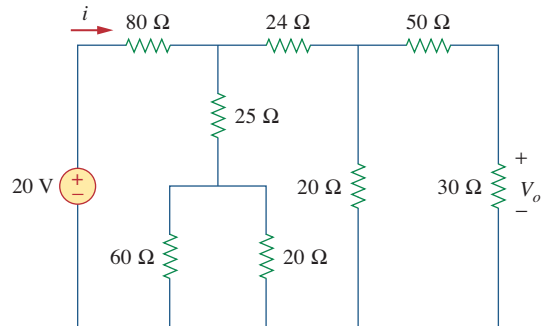

Figure 2.100
For Prob. 2.36.

2.37 Find R for the circuit in Fig. 2.101.

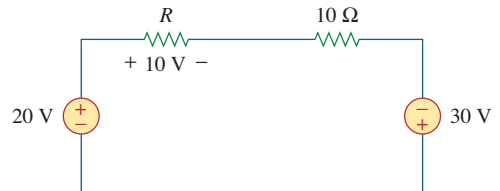

Figure 2.101
For Prob. 2.37.

2.38 Find R_{eq} and i_o in the circuit of Fig. 2.102.

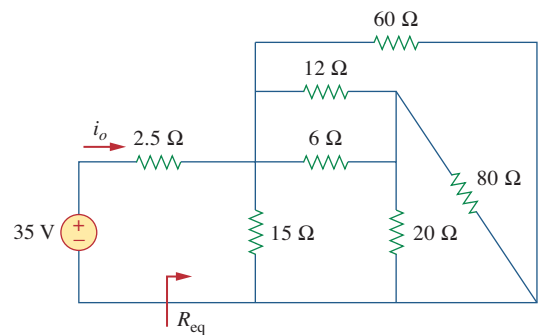

Figure 2.102
For Prob. 2.38.

2.39 Evaluate R_{eq} for each of the circuits shown in Fig. 2.103.

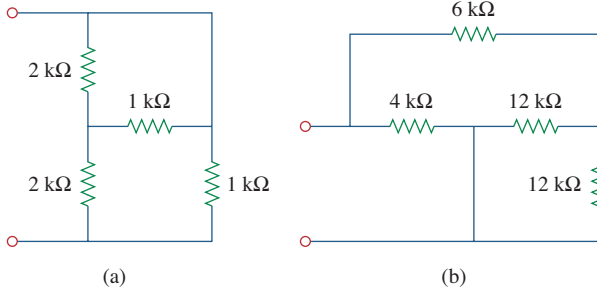

Figure 2.103
For Prob. 2.39.

2.40 For the ladder network in Fig. 2.104, find I and R_{eq} .

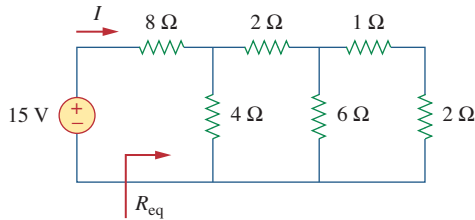

Figure 2.104
For Prob. 2.40.

2.41 If $R_{eq} = 50 \Omega$ in the circuit of Fig. 2.105, find R .

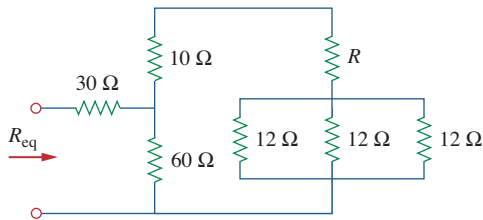

Figure 2.105
For Prob. 2.41.

2.42 Reduce each of the circuits in Fig. 2.106 to a single resistor at terminals $a-b$.

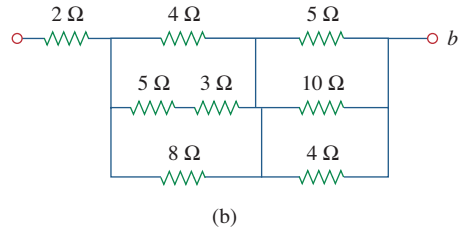
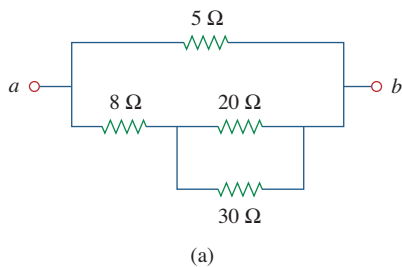

Figure 2.106
For Prob. 2.42.

2.43 Calculate the equivalent resistance R_{ab} at terminals $a-b$ for each of the circuits in Fig. 2.107.

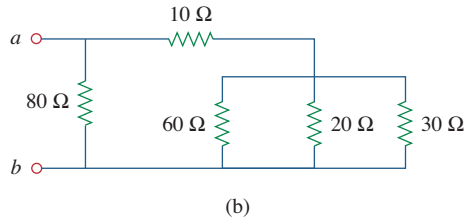
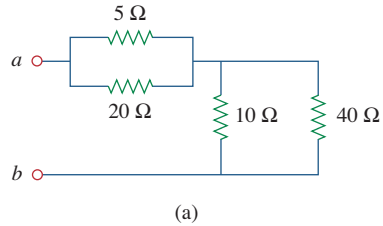

Figure 2.107
For Prob. 2.43.

2.44 For the circuits in Fig. 2.108, obtain the equivalent resistance at terminals $a-b$.

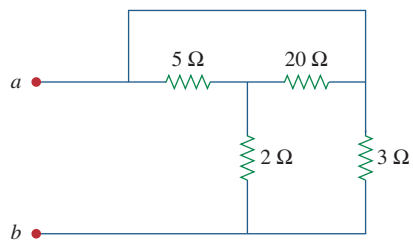

Figure 2.108
For Prob. 2.44.

2.45 Find the equivalent resistance at terminals a - b of each circuit in Fig. 2.109.

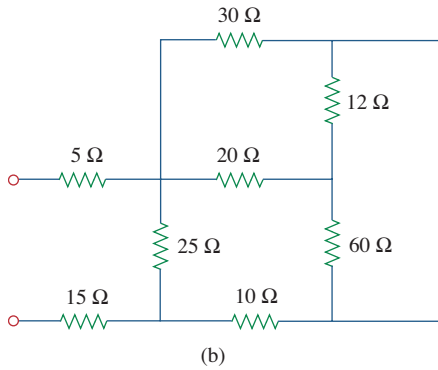
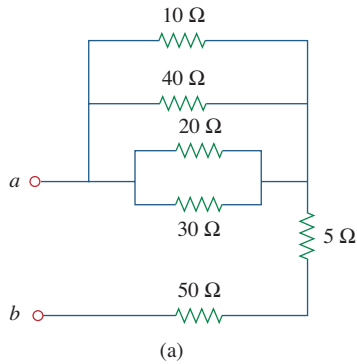

Figure 2.109
For Prob. 2.45.

2.46 Find I in the circuit of Fig. 2.110.

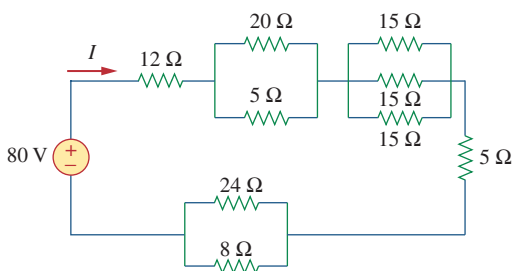

Figure 2.110
For Prob. 2.46.

2.47 Find the equivalent resistance R_{ab} in the circuit of Fig. 2.111.

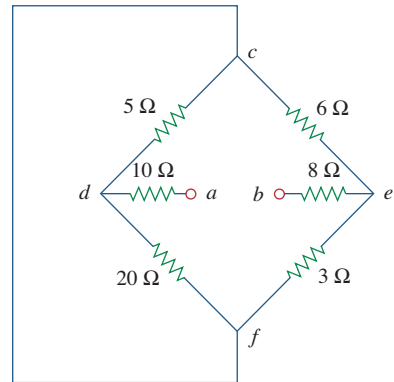

Figure 2.111
For Prob. 2.47.

Section 2.7 Wye-Delta Transformations

2.48 Convert the circuits in Fig. 2.112 from Y to Δ .

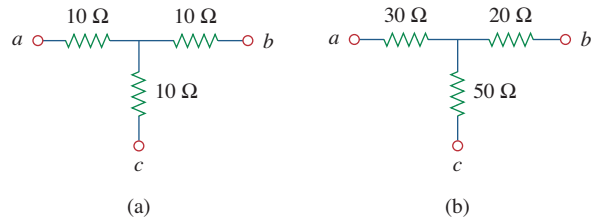

Figure 2.112
For Prob. 2.48.

2.49 Transform the circuits in Fig. 2.113 from Δ to Y.

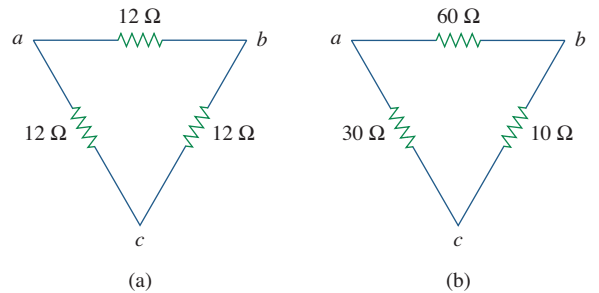

Figure 2.113
For Prob. 2.49.

2.50 Design a problem to help other students better understand wye-delta transformations using Fig. 2.114.

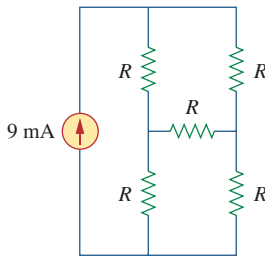
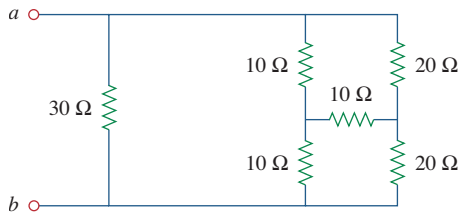

Figure 2.114

For Prob. 2.50.

2.51 Obtain the equivalent resistance at the terminals *a-b* for each of the circuits in Fig. 2.115.



(a)

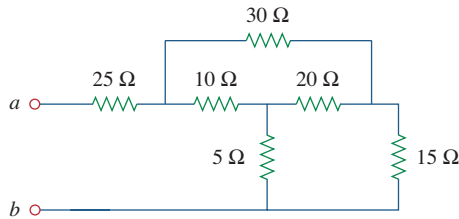

(b)

Figure 2.115

For Prob. 2.51.

***2.52** For the circuit shown in Fig. 2.116, find the equivalent resistance. All resistors are $3\ \Omega$.

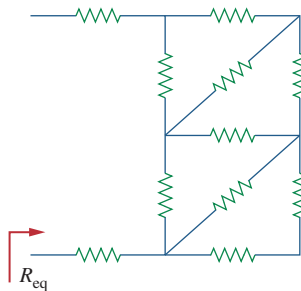
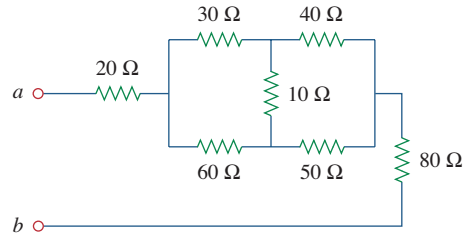

Figure 2.116

For Prob. 2.52.

* An asterisk indicates a challenging problem.

***2.53** Obtain the equivalent resistance R_{ab} in each of the circuits of Fig. 2.117. In (b), all resistors have a value of $30\ \Omega$.



(a)

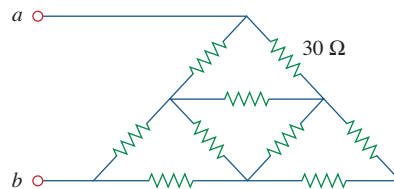

(b)

Figure 2.117

For Prob. 2.53.

2.54 Consider the circuit in Fig. 2.118. Find the equivalent resistance at terminals: (a) *a-b*, (b) *c-d*.

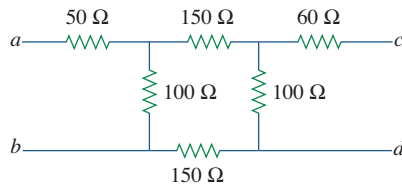

Figure 2.118

For Prob. 2.54.

2.55 Calculate I_o in the circuit of Fig. 2.119.

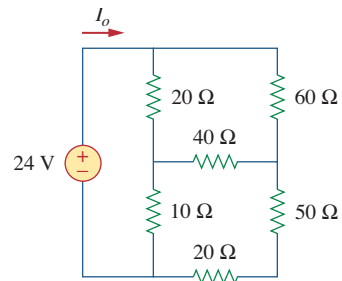

Figure 2.119

For Prob. 2.55.

2.56 Determine V in the circuit of Fig. 2.120.

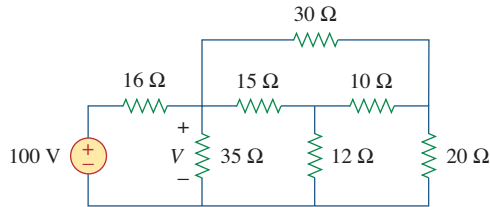

Figure 2.120

For Prob. 2.56.

*2.57 Find R_{eq} and I in the circuit of Fig. 2.121.

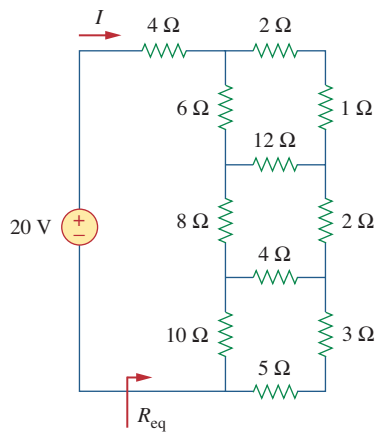

Figure 2.121

For Prob. 2.57.

Section 2.8 Applications

2.58 The 60 W light bulb in Fig. 2.122 is rated at 120 volts. Calculate V_s to make the light bulb operate at the rated conditions.

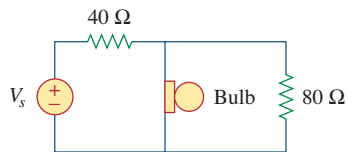

Figure 2.122

For Prob. 2.58.

2.59 Three light bulbs are connected in series to a 120-V source as shown in Fig. 2.123. Find the current I through the bulbs. Each bulb is rated at 120 volts. How much power is each bulb absorbing? Do they generate much light?

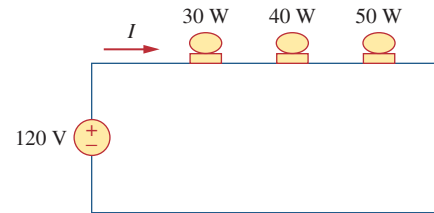



Figure 2.123

For Prob. 2.59.

2.60 If the three bulbs of Prob. 2.59 are connected in parallel to the 120-V source, calculate the current through each bulb.

2.61  As a design engineer, you are asked to design a lighting system consisting of a 70-W power supply and two light bulbs as shown in Fig. 2.124. You must select the two bulbs from the following three available bulbs.

$R_1 = 80 \Omega$, cost = \$0.60 (standard size)

$R_2 = 90 \Omega$, cost = \$0.90 (standard size)

$R_3 = 100 \Omega$, cost = \$0.75 (nonstandard size)

The system should be designed for minimum cost such that lies within the range $I = 1.2 \text{ A} \pm 5$ percent.

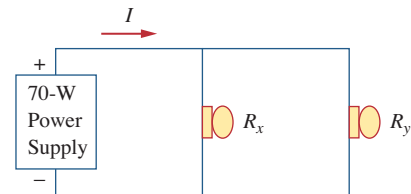

Figure 2.124

For Prob. 2.61.

2.62 A three-wire system supplies two loads A and B as shown in Fig. 2.125. Load A consists of a motor drawing a current of 8 A, while load B is a PC drawing 2 A. Assuming 10 h/day of use for 365 days and 6 cents/kWh, calculate the annual energy cost of the system.

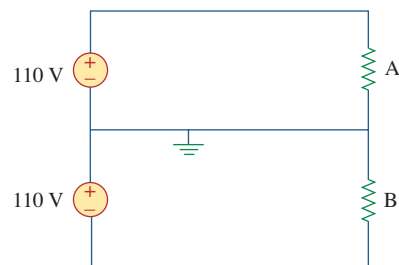

Figure 2.125

For Prob. 2.62.

2.63 If an ammeter with an internal resistance of 100Ω and a current capacity of 2 mA is to measure 5 A, determine the value of the resistance needed.

Calculate the power dissipated in the shunt resistor.

- 2.64** The potentiometer (adjustable resistor) R_x in Fig. 2.126 is to be designed to adjust current i_x from 1 A to 10 A. Calculate the values of R and R_x to achieve this.

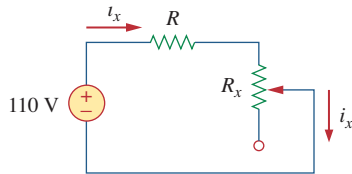

Figure 2.126

For Prob. 2.64.

- 2.65** A d'Arsonval meter with an internal resistance of $1\text{ k}\Omega$ requires 10 mA to produce full-scale deflection. Calculate the value of a series resistance needed to measure 50 V of full scale.
- 2.66** A $20\text{-k}\Omega/\text{V}$ voltmeter reads 10 V full scale.
- What series resistance is required to make the meter read 50 V full scale?
 - What power will the series resistor dissipate when the meter reads full scale?
- 2.67** (a) Obtain the voltage V_o in the circuit of Fig. 2.127(a).
 (b) Determine the voltage V'_o measured when a voltmeter with $6\text{-k}\Omega$ internal resistance is connected as shown in Fig. 2.127(b).

$$\left| \frac{V_o - V'_o}{V_o} \right| \times 100\%$$

- (c) The finite resistance of the meter introduces an error into the measurement. Calculate the percent error as

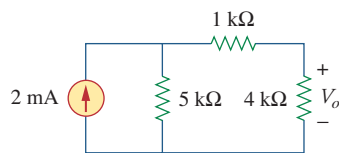

(a)

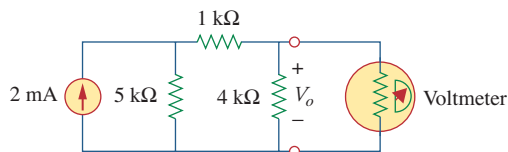

(b)

Figure 2.127

For Prob. 2.67.

- 2.68** (a) Find the current I in the circuit of Fig. 2.128(a).
 (b) An ammeter with an internal resistance of $1\ \Omega$ is inserted in the network to measure I' as shown in Fig. 2.128(b). What is I' ?
 (c) Calculate the percent error introduced by the meter as

$$\left| \frac{I - I'}{I} \right| \times 100\%$$

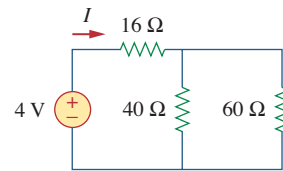

(a)

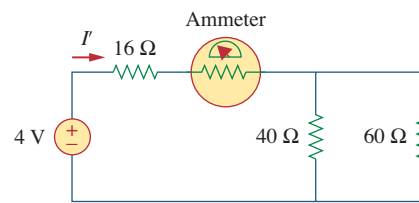

(b)

Figure 2.128

For Prob. 2.68.

- 2.69** A voltmeter is used to measure V_o in the circuit in Fig. 2.129. The voltmeter model consists of an ideal voltmeter in parallel with a $100\text{-k}\Omega$ resistor. Let $V_s = 40\text{ V}$, $R_s = 10\text{ k}\Omega$, and $R_1 = 20\text{ k}\Omega$. Calculate V_o with and without the voltmeter when
- $R_2 = 1\text{ k}\Omega$
 - $R_2 = 10\text{ k}\Omega$
 - $R_2 = 100\text{ k}\Omega$

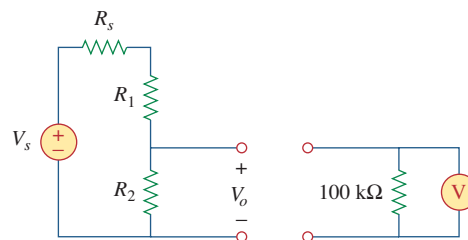

Figure 2.129

For Prob. 2.69.

- 2.70 (a) Consider the Wheatstone bridge shown in Fig. 2.130. Calculate v_a , v_b , and v_{ab} .
 (b) Rework part (a) if the ground is placed at a instead of o .

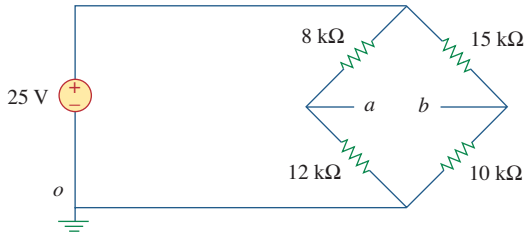

Figure 2.130
 For Prob. 2.70.

- 2.71 Figure 2.131 represents a model of a solar photovoltaic panel. Given that $V_s = 30$ V, $R_1 = 20$ Ω, and $i_L = 1$ A, find R_L .

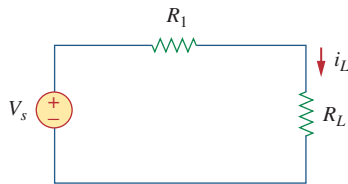

Figure 2.131
 For Prob. 2.71.

- 2.72 Find V_o in the two-way power divider circuit in Fig. 2.132.

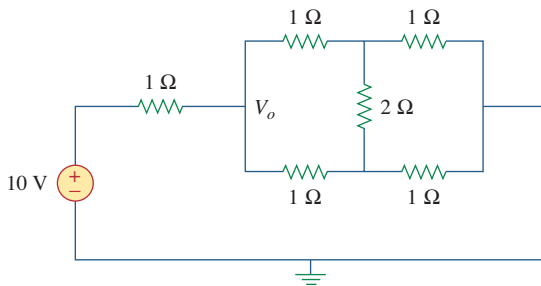

Figure 2.132
 For Prob. 2.72.

- 2.73 An ammeter model consists of an ideal ammeter in series with a 20-Ω resistor. It is connected with a current source and an unknown resistor R_x as shown in Fig. 2.133. The ammeter reading is noted. When a potentiometer R is added and adjusted until the ammeter reading drops to one half its previous reading, then $R = 65$ Ω. What is the value of R_x ?

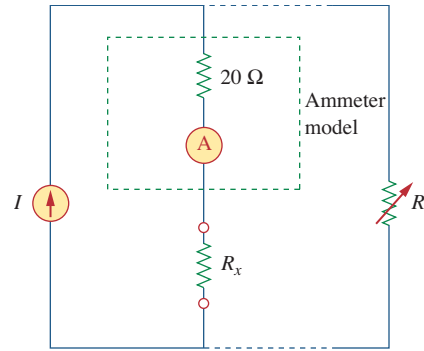

Figure 2.133
 For Prob. 2.73.

- 2.74 The circuit in Fig. 2.134 is to control the speed of a motor such that the motor draws currents 5 A, 3 A, and 1 A when the switch is at high, medium, and low positions, respectively. The motor can be modeled as a load resistance of 20 mΩ. Determine the series dropping resistances R_1 , R_2 , and R_3 .

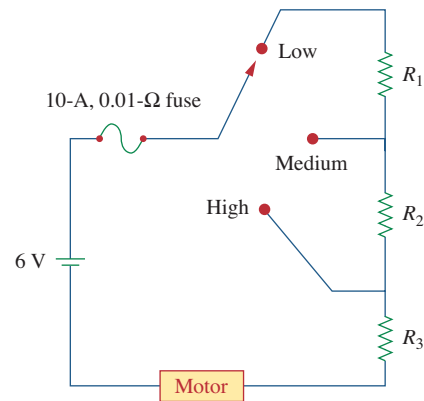

Figure 2.134
 For Prob. 2.74.

- 2.75 Find R_{ab} in the four-way power divider circuit in Fig. 2.135. Assume each element is 1 Ω.

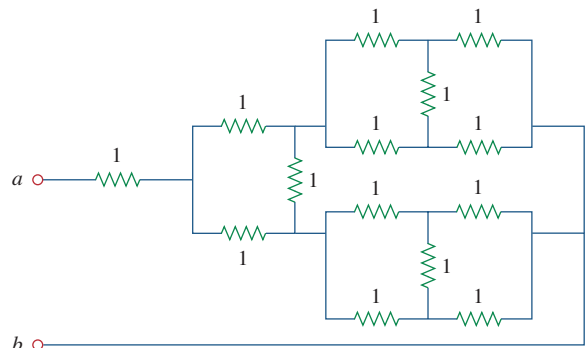

Figure 2.135
 For Prob. 2.75.

Comprehensive Problems

2.76 Repeat Prob. 2.75 for the eight-way divider shown in Fig. 2.136.

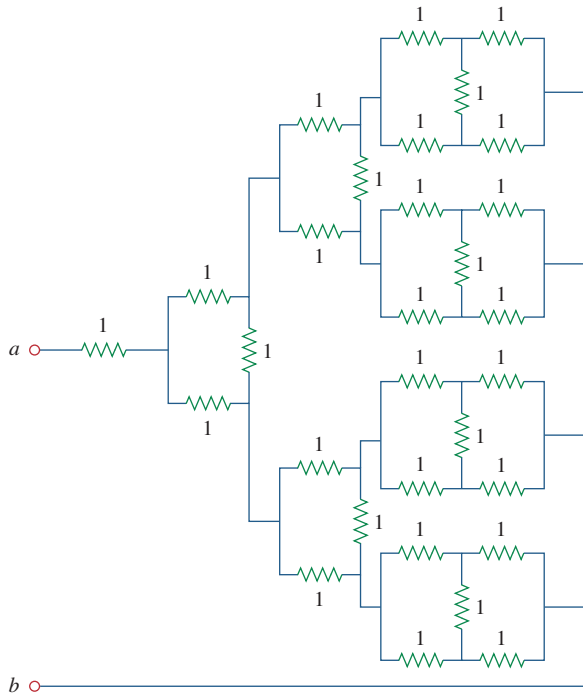

Figure 2.136

For Prob. 2.76.

2.77 Suppose your circuit laboratory has the following standard commercially available resistors in large quantities:

e7d

1.8 Ω 20 Ω 300 Ω 24 k Ω 56 k Ω

Using series and parallel combinations and a minimum number of available resistors, how would you obtain the following resistances for an electronic circuit design?

- (a) 5 Ω (b) 311.8 Ω
 (c) 40 k Ω (d) 52.32 k Ω

2.78 In the circuit in Fig. 2.137, the wiper divides the potentiometer resistance between αR and $(1 - \alpha)R$, $0 \leq \alpha \leq 1$. Find v_o/v_s .

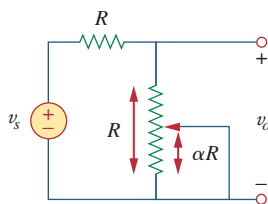

Figure 2.137

For Prob. 2.78.

2.79 An electric pencil sharpener rated 240 mW, 6 V is connected to a 9-V battery as shown in Fig. 2.138. Calculate the value of the series-dropping resistor R_x needed to power the sharpener.

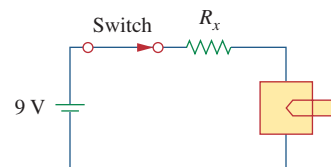

Figure 2.138

For Prob. 2.79.

2.80 A loudspeaker is connected to an amplifier as shown in Fig. 2.139. If a 10- Ω loudspeaker draws the maximum power of 12 W from the amplifier, determine the maximum power a 4- Ω loudspeaker will draw.



Figure 2.139

For Prob. 2.80.

2.81 In a certain application, the circuit in Fig. 2.140 must be designed to meet these two criteria:

- (a) $V_o/V_s = 0.05$ (b) $R_{eq} = 40$ k Ω

If the load resistor 5 k Ω is fixed, find R_1 and R_2 to meet the criteria.

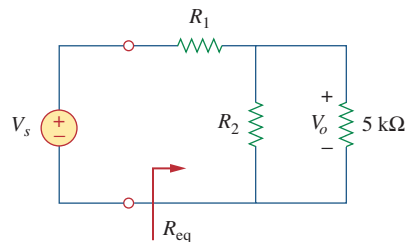

Figure 2.140

For Prob. 2.81.

2.82 The pin diagram of a resistance array is shown in Fig. 2.141. Find the equivalent resistance between the following:

- (a) 1 and 2
- (b) 1 and 3
- (c) 1 and 4

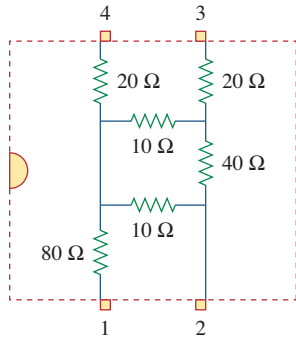

Figure 2.141
For Prob. 2.82.

2.83 Two delicate devices are rated as shown in Fig. 2.142. Find the values of the resistors R_1 and R_2 needed to power the devices using a 24-V battery.

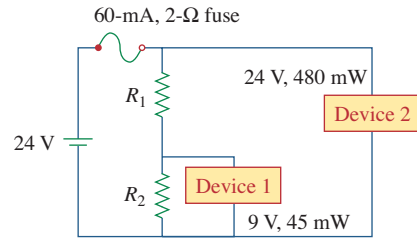

Figure 2.142
For Prob. 2.83.

