

Analysis and Design of Beams for Bending

5



The beams supporting the multiple overhead cranes system shown in this picture are subjected to transverse loads causing the beams to bend. The normal stresses resulting from such loadings will be determined in this chapter.

5.1. INTRODUCTION

This chapter and most of the next one will be devoted to the analysis and the design of *beams*, i.e., structural members supporting loads applied at various points along the member. Beams are usually long, straight prismatic members, as shown in the photo on the previous page. Steel and aluminum beams play an important part in both structural and mechanical engineering. Timber beams are widely used in home construction (Fig. 5.1). In most cases, the loads are perpendicular to the axis of the beam. Such a *transverse loading* causes only bending and shear in the beam. When the loads are not at a right angle to the beam, they also produce axial forces in the beam.



Fig. 5.1

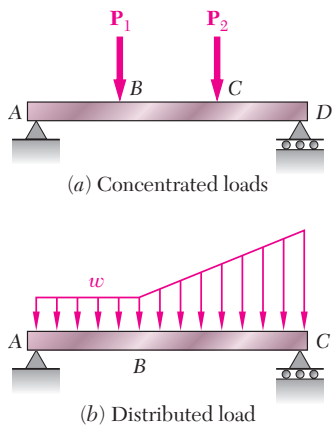
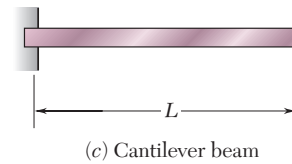
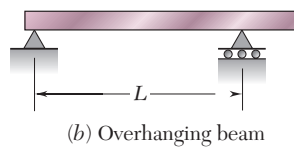
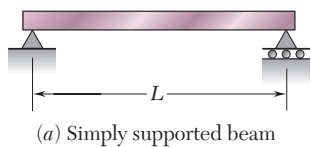

Fig. 5.2

The transverse loading of a beam may consist of *concentrated loads* P_1, P_2, \dots , expressed in newtons, pounds, or their multiples, kilonewtons and kips (Fig. 5.2a), of a *distributed load* w , expressed in N/m, kN/m, lb/ft, or kips/ft (Fig. 5.2b), or of a combination of both. When the load w per unit length has a constant value over part of the beam (as between A and B in Fig. 5.2b), the load is said to be *uniformly distributed* over that part of the beam.

Beams are classified according to the way in which they are supported. Several types of beams frequently used are shown in Fig. 5.3. The distance L shown in the various parts of the figure is called the *span*. Note that the reactions at the supports of the beams in parts a, b, and c of the figure involve a total of only three unknowns and, therefore, can be determined by

Statically Determinate Beams



Statically Indeterminate Beams

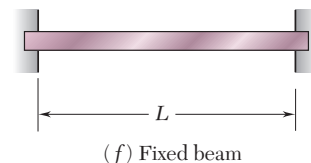
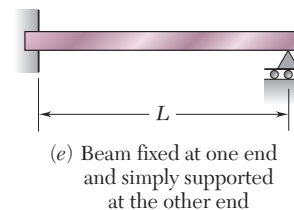
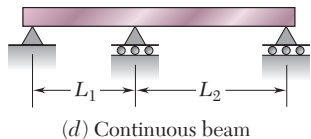

Fig. 5.3

the methods of statics. Such beams are said to be *statically determinate* and will be discussed in this chapter and the next. On the other hand, the reactions at the supports of the beams in parts *d*, *e*, and *f* of Fig. 5.3 involve more than three unknowns and cannot be determined by the methods of statics alone. The properties of the beams with regard to their resistance to deformations must be taken into consideration. Such beams are said to be *statically indeterminate* and their analysis will be postponed until Chap. 9, where deformations of beams will be discussed.

Sometimes two or more beams are connected by hinges to form a single continuous structure. Two examples of beams hinged at a point *H* are shown in Fig. 5.4. It will be noted that the reactions at the supports involve four unknowns and cannot be determined from the free-body diagram of the two-beam system. They can be determined, however, by considering the free-body diagram of each beam separately; six unknowns are involved (including two force components at the hinge), and six equations are available.

It was shown in Sec. 4.1 that if we pass a section through a point *C* of a cantilever beam supporting a concentrated load **P** at its end (Fig. 4.6), the internal forces in the section are found to consist of a shear force **P'** equal and opposite to the load **P** and a bending couple **M** of moment equal to the moment of **P** about *C*. A similar situation prevails for other types of supports and loadings. Consider, for example, a simply supported beam *AB* carrying two concentrated loads and a uniformly distributed load (Fig. 5.5*a*). To determine the internal forces in a section through point *C* we first draw the free-body diagram of the entire beam to obtain the reactions at the supports (Fig. 5.5*b*). Passing a section through *C*, we then draw the free-body diagram of *AC* (Fig. 5.5*c*), from which we determine the shear force **V** and the bending couple **M**.

The bending couple **M** creates *normal stresses* in the cross section, while the shear force **V** creates *shearing stresses* in that section. In most cases the dominant criterion in the design of a beam for strength is the maximum value of the normal stress in the beam. The determination of the normal stresses in a beam will be the subject of this chapter, while shearing stresses will be discussed in Chap. 6.

Since the distribution of the normal stresses in a given section depends only upon the value of the bending moment *M* in that section and the geometry of the section,† the elastic flexure formulas derived in Sec. 4.4 can be used to determine the maximum stress, as well as the stress at any given point, in the section. We write‡

$$\sigma_m = \frac{|M|c}{I} \quad \sigma_x = -\frac{My}{I} \quad (5.1, 5.2)$$

where *I* is the moment of inertia of the cross section with respect to a centroidal axis perpendicular to the plane of the couple, *y* is the distance from the neutral surface, and *c* is the maximum value of that distance (Fig. 4.13). We also recall from Sec. 4.4 that, introducing the

†It is assumed that the distribution of the normal stresses in a given cross section is not affected by the deformations caused by the shearing stresses. This assumption will be verified in Sec. 6.5.

‡We recall from Sec. 4.2 that *M* can be positive or negative, depending upon whether the concavity of the beam at the point considered faces upward or downward. Thus, in the case considered here of a transverse loading, the sign of *M* can vary along the beam. On the other hand, σ_m is a positive quantity, the absolute value of *M* is used in Eq. (5.1).

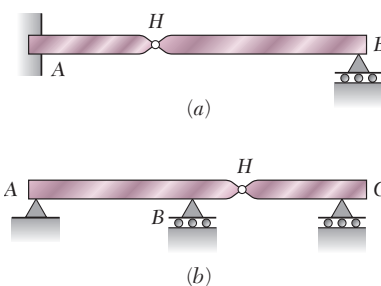

Fig. 5.4

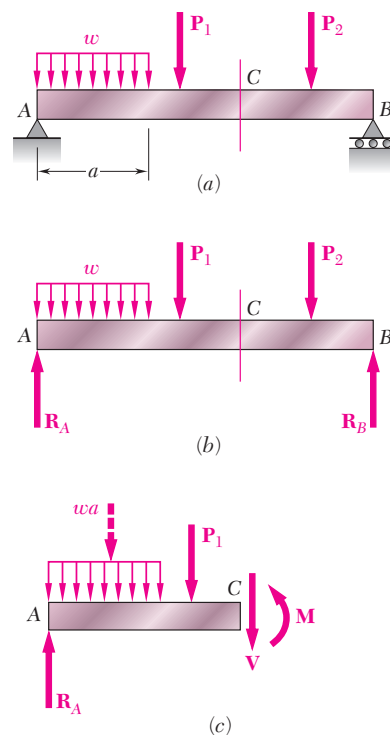

Fig. 5.5

elastic section modulus $S = I/c$ of the beam, the maximum value σ_m of the normal stress in the section can be expressed as

$$\sigma_m = \frac{|M|}{S} \quad (5.3)$$

The fact that σ_m is inversely proportional to S underlines the importance of selecting beams with a large section modulus. Section moduli of various rolled-steel shapes are given in Appendix C, while the section modulus of a rectangular shape can be expressed, as shown in Sec. 4.4, as

$$S = \frac{1}{6}bh^2 \quad (5.4)$$

where b and h are, respectively, the width and the depth of the cross section.

Equation (5.3) also shows that, for a beam of uniform cross section, σ_m is proportional to $|M|$: Thus, the maximum value of the normal stress in the beam occurs in the section where $|M|$ is largest. It follows that one of the most important parts of the design of a beam for a given loading condition is the determination of the location and magnitude of the largest bending moment.

This task is made easier if a *bending-moment diagram* is drawn, i.e., if the value of the bending moment M is determined at various points of the beam and plotted against the distance x measured from one end of the beam. It is further facilitated if a *shear diagram* is drawn at the same time by plotting the shear V against x .

The sign convention to be used to record the values of the shear and bending moment will be discussed in Sec. 5.2. The values of V and M will then be obtained at various points of the beam by drawing free-body diagrams of successive portions of the beam. In Sec. 5.3 relations among load, shear, and bending moment will be derived and used to obtain the shear and bending-moment diagrams. This approach facilitates the determination of the largest absolute value of the bending moment and, thus, the determination of the maximum normal stress in the beam.

In Sec. 5.4 you will learn to design a beam for bending, i.e., so that the maximum normal stress in the beam will not exceed its allowable value. As indicated earlier, this is the dominant criterion in the design of a beam.

Another method for the determination of the maximum values of the shear and bending moment, based on expressing V and M in terms of *singularity functions*, will be discussed in Sec. 5.5. This approach lends itself well to the use of computers and will be expanded in Chap. 9 to facilitate the determination of the slope and deflection of beams.

Finally, the design of *nonprismatic beams*, i.e., beams with a variable cross section, will be discussed in Sec. 5.6. By selecting the shape and size of the variable cross section so that its elastic section modulus $S = I/c$ varies along the length of the beam in the same way as $|M|$, it is possible to design beams for which the maximum normal stress in each section is equal to the allowable stress of the material. Such beams are said to be of *constant strength*.

As indicated in Sec. 5.1, the determination of the maximum absolute values of the shear and of the bending moment in a beam are greatly facilitated if V and M are plotted against the distance x measured from one end of the beam. Besides, as you will see in Chap. 9, the knowledge of M as a function of x is essential to the determination of the deflection of a beam.

In the examples and sample problems of this section, the shear and bending-moment diagrams will be obtained by determining the values of V and M at selected points of the beam. These values will be found in the usual way, i.e., by passing a section through the point where they are to be determined (Fig. 5.6a) and considering the equilibrium of the portion of beam located on either side of the section (Fig. 5.6b). Since the shear forces V and V' have opposite senses, recording the shear at point C with an up or down arrow would be meaningless, unless we indicated at the same time which of the free bodies AC and CB we are considering. For this reason, the shear V will be recorded with a sign: a *plus sign* if the shearing forces are directed as shown in Fig. 5.6b, and a *minus sign* otherwise. A similar convention will apply for the bending moment M . It will be considered as positive if the bending couples are directed as shown in that figure, and negative otherwise.† Summarizing the sign conventions we have presented, we state:

The shear V and the bending moment M at a given point of a beam are said to be positive when the internal forces and couples acting on each portion of the beam are directed as shown in Fig. 5.7a.

These conventions can be more easily remembered if we note that

1. The shear at any given point of a beam is positive when the external forces (loads and reactions) acting on the beam tend to shear off the beam at that point as indicated in Fig. 5.7b.
2. The bending moment at any given point of a beam is positive when the external forces acting on the beam tend to bend the beam at that point as indicated in Fig. 5.7c.

It is also of help to note that the situation described in Fig. 5.7, in which the values of the shear and of the bending moment are positive, is precisely the situation that occurs in the left half of a simply supported beam carrying a single concentrated load at its midpoint. This particular case is fully discussed in the next example.

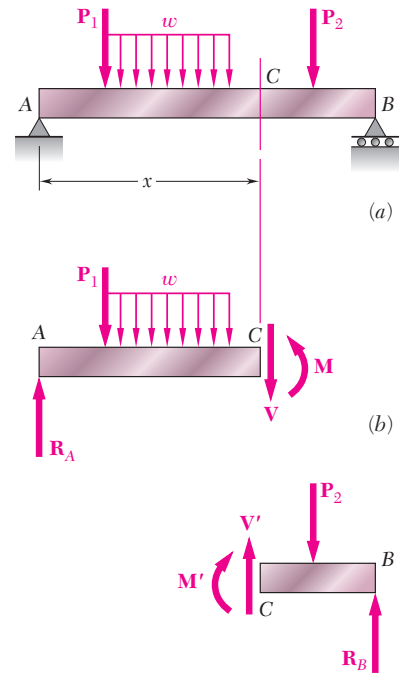

Fig. 5.6

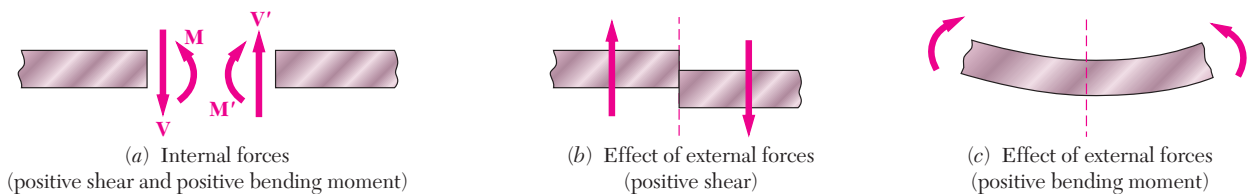

Fig. 5.7

†Note that this convention is the same that we used earlier in Sec. 4.2

EXAMPLE 5.01

Draw the shear and bending-moment diagrams for a simply supported beam AB of span L subjected to a single concentrated load P at its midpoint C (Fig. 5.8).

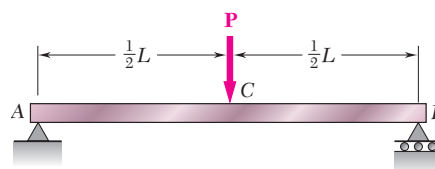
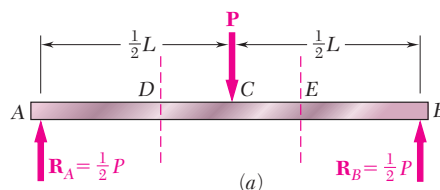
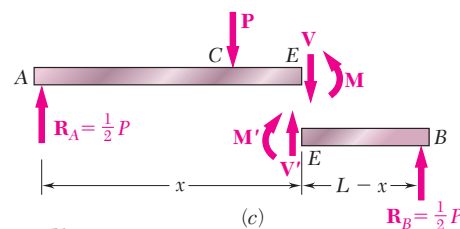
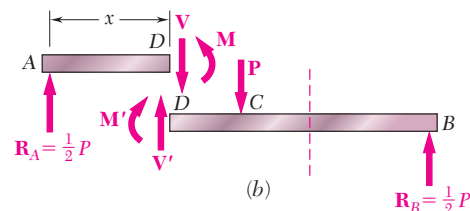

Fig. 5.8

We first determine the reactions at the supports from the free-body diagram of the entire beam (Fig. 5.9a); we find that the magnitude of each reaction is equal to $P/2$.



Next we cut the beam at a point D between A and C and draw the free-body diagrams of AD and DB (Fig. 5.9b). Assuming that shear and bending moment are positive, we direct the internal forces V and V' and the internal couples M and M' as indicated in Fig. 5.7a. Considering the free body AD and writing that the sum of the vertical components and the sum of the moments about D of the forces acting on the free body are zero, we find $V = +P/2$ and $M = +Px/2$. Both the shear and the bending moment are therefore positive; this may be checked by observing that the reaction at A tends to shear off and to bend the beam at D as indicated in Figs. 5.7b and c. We now plot V and M between A and C (Figs. 5.9d and e); the shear has a constant value $V = P/2$, while the bending moment increases linearly from $M = 0$ at $x = 0$ to $M = PL/4$ at $x = L/2$.



Cutting, now, the beam at a point E between C and B and considering the free body EB (Fig. 5.9c), we write that the sum of the vertical components and the sum of the moments about E of the forces acting on the free body are zero. We obtain $V = -P/2$ and $M = P(L - x)/2$. The shear is therefore negative and the bending moment positive; this can be checked by observing that the reaction at B bends the beam at E as indicated in Fig. 5.7c but tends to shear it off in a manner opposite to that shown in Fig. 5.7b. We can complete, now, the shear and bending-moment diagrams of Figs. 5.9d and e; the shear has a constant value $V = -P/2$ between C and B , while the bending moment decreases linearly from $M = PL/4$ at $x = L/2$ to $M = 0$ at $x = L$.

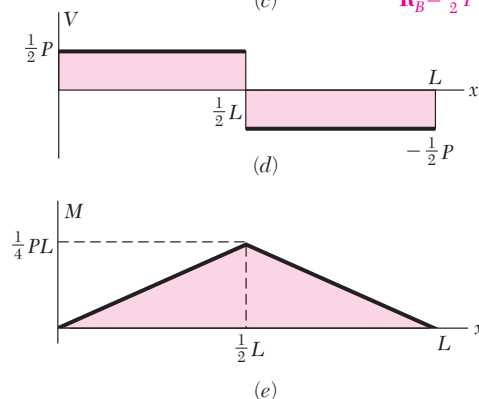

Fig. 5.9

We note from the foregoing example that, when a beam is subjected only to concentrated loads, the shear is constant between loads and the bending moment varies linearly between loads. In such situations, therefore, the shear and bending-moment diagrams can easily be drawn, once the values of V and M have been obtained at sections selected just to the left and just to the right of the points where the loads and reactions are applied (see Sample Prob. 5.1).

EXAMPLE 5.02

Draw the shear and bending-moment diagrams for a cantilever beam AB of span L supporting a uniformly distributed load w (Fig. 5.10).

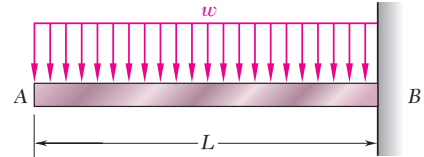
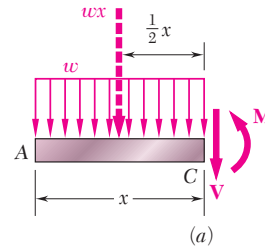

Fig. 5.10

We cut the beam at a point C between A and B and draw the free-body diagram of AC (Fig. 5.11a), directing \mathbf{V} and \mathbf{M} as indicated in Fig. 5.7a. Denoting by x the distance from A to C and replacing the distributed load over AC by its resultant $w x$ applied at the midpoint of AC , we write



$$+\uparrow \Sigma F_y = 0: \quad -wx - V = 0 \quad V = -wx$$

$$+\curvearrowright \Sigma M_C = 0: \quad wx \left(\frac{x}{2} \right) + M = 0 \quad M = -\frac{1}{2}wx^2$$

We note that the shear diagram is represented by an oblique straight line (Fig. 5.11b) and the bending-moment diagram by a parabola (Fig. 5.11c). The maximum values of V and M both occur at B , where we have

$$V_B = -wL \quad M_B = -\frac{1}{2}wL^2$$

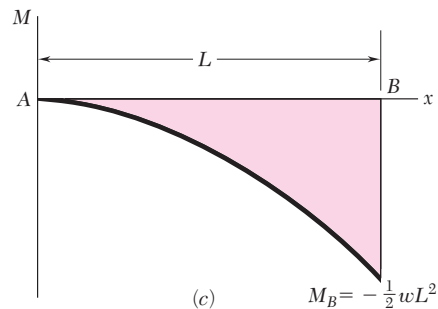
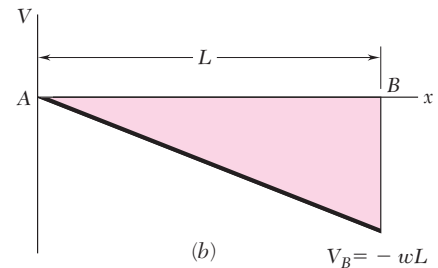
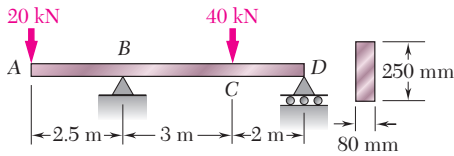
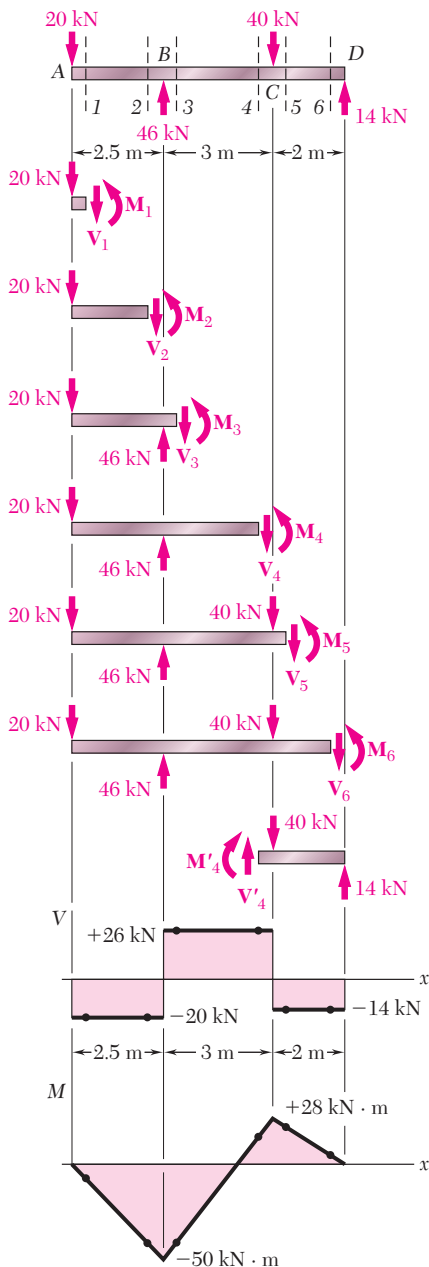

Fig. 5.11



SAMPLE PROBLEM 5.1

For the timber beam and loading shown, draw the shear and bending-moment diagrams and determine the maximum normal stress due to bending.



SOLUTION

Reactions. Considering the entire beam as a free body, we find

$$R_B = 40 \text{ kN } \uparrow \quad R_D = 14 \text{ kN } \uparrow$$

Shear and Bending-Moment Diagrams. We first determine the internal forces just to the right of the 20-kN load at A. Considering the stub of beam to the left of section 1 as a free body and assuming V and M to be positive (according to the standard convention), we write

$$\begin{aligned} +\uparrow \Sigma F_y = 0: & \quad -20 \text{ kN} - V_1 = 0 & \quad V_1 = -20 \text{ kN} \\ +\curvearrowright \Sigma M_1 = 0: & \quad (20 \text{ kN})(0 \text{ m}) + M_1 = 0 & \quad M_1 = 0 \end{aligned}$$

We next consider as a free body the portion of beam to the left of section 2 and write

$$\begin{aligned} +\uparrow \Sigma F_y = 0: & \quad -20 \text{ kN} - V_2 = 0 & \quad V_2 = -20 \text{ kN} \\ +\curvearrowright \Sigma M_2 = 0: & \quad (20 \text{ kN})(2.5 \text{ m}) + M_2 = 0 & \quad M_2 = -50 \text{ kN} \cdot \text{m} \end{aligned}$$

The shear and bending moment at sections 3, 4, 5, and 6 are determined in a similar way from the free-body diagrams shown. We obtain

$$\begin{aligned} V_3 &= +26 \text{ kN} & M_3 &= -50 \text{ kN} \cdot \text{m} \\ V_4 &= +26 \text{ kN} & M_4 &= +28 \text{ kN} \cdot \text{m} \\ V_5 &= -14 \text{ kN} & M_5 &= +28 \text{ kN} \cdot \text{m} \\ V_6 &= -14 \text{ kN} & M_6 &= 0 \end{aligned}$$

For several of the latter sections, the results may be more easily obtained by considering as a free body the portion of the beam to the right of the section. For example, for the portion of the beam to the right of section 4, we have

$$\begin{aligned} +\uparrow \Sigma F_y = 0: & \quad V_4 - 40 \text{ kN} + 14 \text{ kN} = 0 & \quad V_4 = +26 \text{ kN} \\ +\curvearrowright \Sigma M_4 = 0: & \quad -M_4 + (14 \text{ kN})(2 \text{ m}) = 0 & \quad M_4 = +28 \text{ kN} \cdot \text{m} \end{aligned}$$

We can now plot the six points shown on the shear and bending-moment diagrams. As indicated earlier in this section, the shear is of constant value between concentrated loads, and the bending moment varies linearly; we obtain therefore the shear and bending-moment diagrams shown.

Maximum Normal Stress. It occurs at B, where $|M|$ is largest. We use Eq. (5.4) to determine the section modulus of the beam:

$$S = \frac{1}{6}bh^2 = \frac{1}{6}(0.080 \text{ m})(0.250 \text{ m})^2 = 833.33 \times 10^{-6} \text{ m}^3$$

Substituting this value and $|M| = |M_B| = 50 \times 10^3 \text{ N} \cdot \text{m}$ into Eq. (5.3):

$$\sigma_m = \frac{|M_B|}{S} = \frac{(50 \times 10^3 \text{ N} \cdot \text{m})}{833.33 \times 10^{-6}} = 60.00 \times 10^6 \text{ Pa}$$

Maximum normal stress in the beam = 60.0 MPa ◀

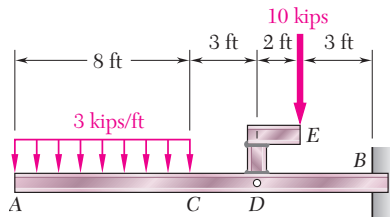

SAMPLE PROBLEM 5.2

The structure shown consists of a W10 × 112 rolled-steel beam AB and of two short members welded together and to the beam. (a) Draw the shear and bending-moment diagrams for the beam and the given loading. (b) Determine the maximum normal stress in sections just to the left and just to the right of point D .

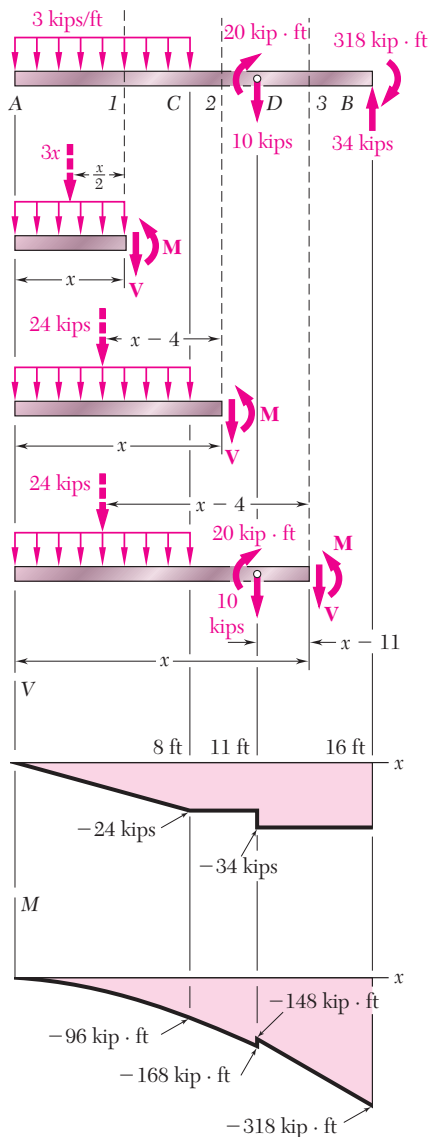

SOLUTION

Equivalent Loading of Beam. The 10-kip load is replaced by an equivalent force-couple system at D . The reaction at B is determined by considering the beam as a free body.

a. Shear and Bending-Moment Diagrams

From A to C. We determine the internal forces at a distance x from point A by considering the portion of beam to the left of section 1. That part of the distributed load acting on the free body is replaced by its resultant, and we write

$$\begin{aligned} +\uparrow \Sigma F_y = 0: & \quad -3x - V = 0 & \quad V = -3x \text{ kips} \\ +\uparrow \Sigma M_1 = 0: & \quad 3x\left(\frac{1}{2}x\right) + M = 0 & \quad M = -1.5x^2 \text{ kip} \cdot \text{ft} \end{aligned}$$

Since the free-body diagram shown can be used for all values of x smaller than 8 ft, the expressions obtained for V and M are valid in the region $0 < x < 8$ ft.

From C to D. Considering the portion of beam to the left of section 2 and again replacing the distributed load by its resultant, we obtain

$$\begin{aligned} +\uparrow \Sigma F_y = 0: & \quad -24 - V = 0 & \quad V = -24 \text{ kips} \\ +\uparrow \Sigma M_2 = 0: & \quad 24(x - 4) + M = 0 & \quad M = 96 - 24x \text{ kip} \cdot \text{ft} \end{aligned}$$

These expressions are valid in the region $8 \text{ ft} < x < 11$ ft.

From D to B. Using the position of beam to the left of section 3, we obtain for the region $11 \text{ ft} < x < 16$ ft

$$V = -34 \text{ kips} \quad M = 226 - 34x \quad \text{kip} \cdot \text{ft}$$

The shear and bending-moment diagrams for the entire beam can now be plotted. We note that the couple of moment $20 \text{ kip} \cdot \text{ft}$ applied at point D introduces a discontinuity into the bending-moment diagram.

b. Maximum Normal Stress to the Left and Right of Point D. From Appendix C we find that for the W10 × 112 rolled-steel shape, $S = 126 \text{ in}^3$ about the $X-X$ axis.

To the left of D: We have $|M| = 168 \text{ kip} \cdot \text{ft} = 2016 \text{ kip} \cdot \text{in}$. Substituting for $|M|$ and S into Eq. (5.3), we write

$$\sigma_m = \frac{|M|}{S} = \frac{2016 \text{ kip} \cdot \text{in.}}{126 \text{ in}^3} = 16.00 \text{ ksi} \quad \sigma_m = 16.00 \text{ ksi} \quad \blacktriangleleft$$

To the right of D: We have $|M| = 148 \text{ kip} \cdot \text{ft} = 1776 \text{ kip} \cdot \text{in}$. Substituting for $|M|$ and S into Eq. (5.3), we write

$$\sigma_m = \frac{|M|}{S} = \frac{1776 \text{ kip} \cdot \text{in.}}{126 \text{ in}^3} = 14.10 \text{ ksi} \quad \sigma_m = 14.10 \text{ ksi} \quad \blacktriangleleft$$

PROBLEMS

5.1 through 5.6 For the beam and loading shown, (a) draw the shear and bending-moment diagrams, (b) determine the equations of the shear and bending-moment curves.

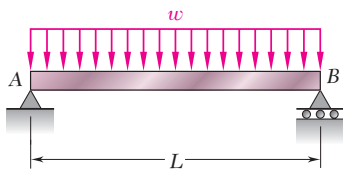

Fig. P5.1

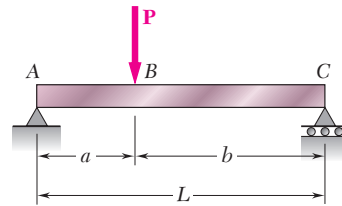

Fig. P5.2

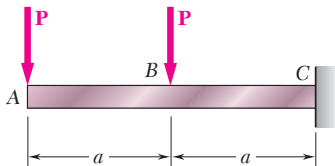

Fig. P5.3

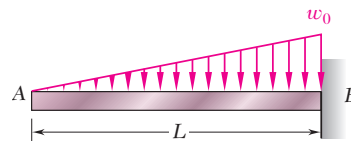

Fig. P5.4

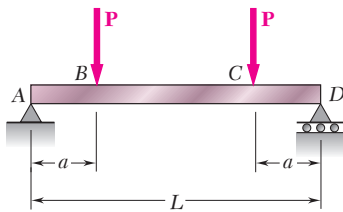

Fig. P5.5

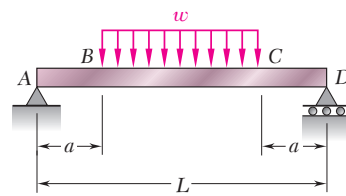

Fig. P5.6

5.7 and 5.8 Draw the shear and bending-moment diagrams for the beam and loading shown, and determine the maximum absolute value (a) of the shear, (b) of the bending moment.

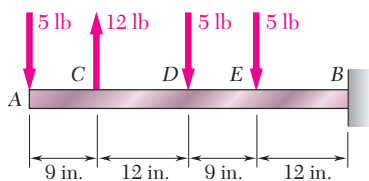

Fig. P5.7

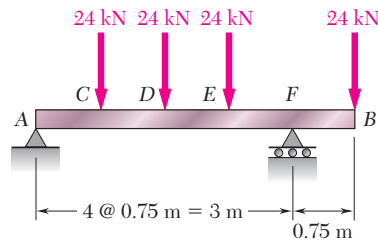

Fig. P5.8

5.9 and 5.10 Draw the shear and bending-moment diagrams for the beam and loading shown, and determine the maximum absolute value (a) of the shear, (b) of the bending moment.

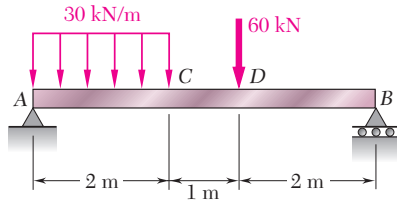

Fig. P5.9

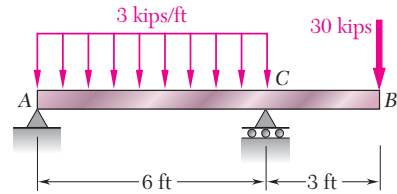

Fig. P5.10

5.11 and 5.12 Draw the shear and bending-moment diagrams for the beam and loading shown, and determine the maximum absolute value (a) of the shear, (b) of the bending moment.

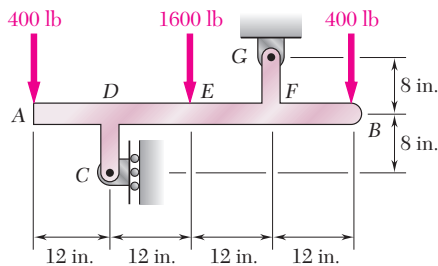

Fig. P5.11

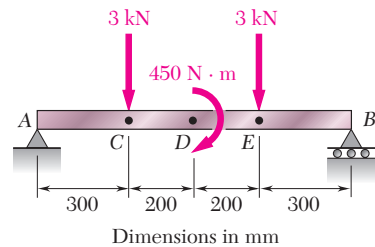

Fig. P5.12

5.13 and 5.14 Assuming that the reaction of the ground to be uniformly distributed, draw the shear and bending-moment diagrams for the beam AB and determine the maximum absolute value (a) of the shear, (b) of the bending moment.

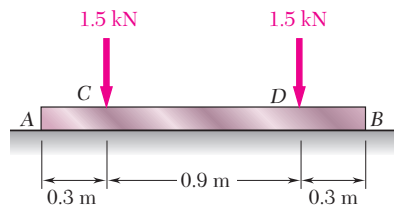

Fig. P5.13

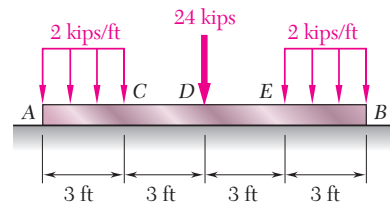

Fig. P5.14

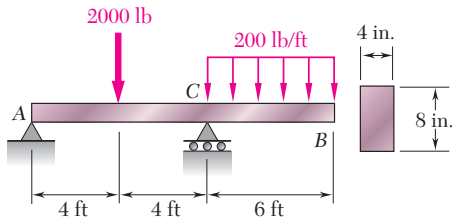

Fig. P5.15

5.15 and 5.16 For the beam and loading shown, determine the maximum normal stress due to bending on a transverse section at C.

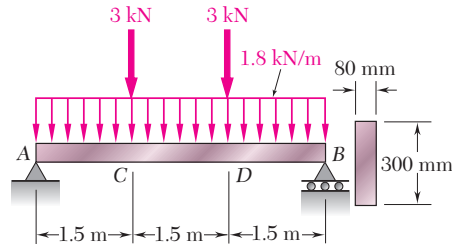

Fig. P5.16

5.17 For the beam and loading shown, determine the maximum normal stress due to bending on a transverse section at C.

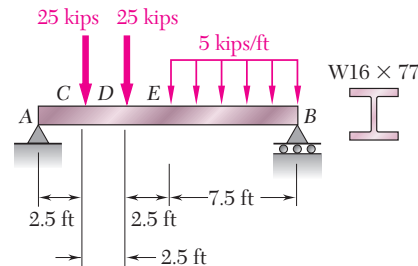

Fig. P5.17

5.18 For the beam and loading shown, determine the maximum normal stress due to bending on section *a-a*.

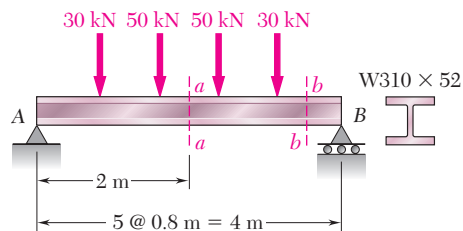

Fig. P5.18

5.19 and 5.20 For the beam and loading shown, determine the maximum normal stress due to bending on a transverse section at C.

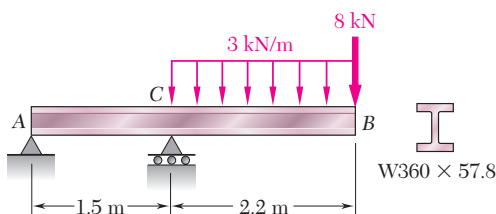

Fig. P5.19

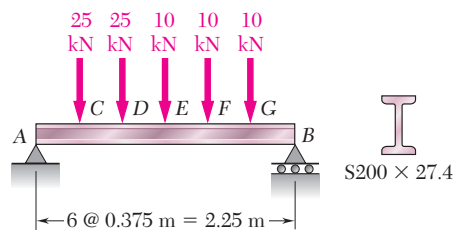

Fig. P5.20

5.21 Draw the shear and bending-moment diagrams for the beam and loading shown and determine the maximum normal stress due to bending.

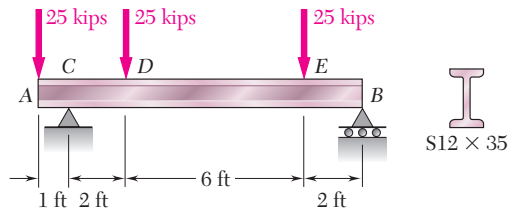

Fig. P5.21

5.22 and 5.23 Draw the shear and bending-moment diagrams for the beam and loading shown and determine the maximum normal stress due to bending.

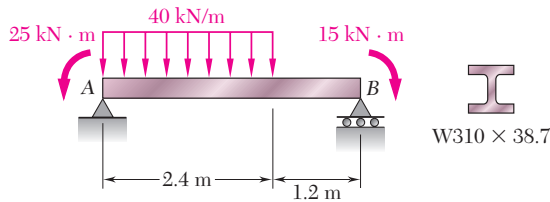

Fig. P5.22

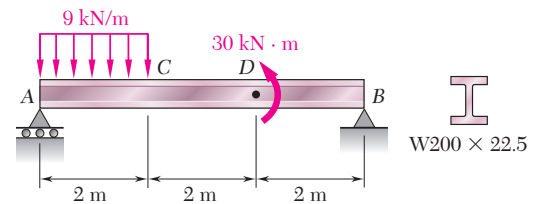

Fig. P5.23

5.24 and 5.25 Draw the shear and bending-moment diagrams for the beam and loading shown and determine the maximum normal stress due to bending.

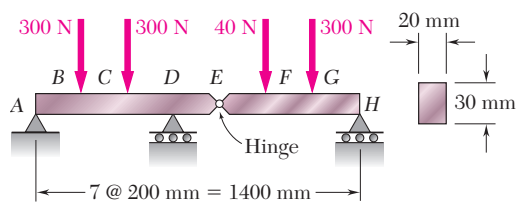

Fig. P5.24

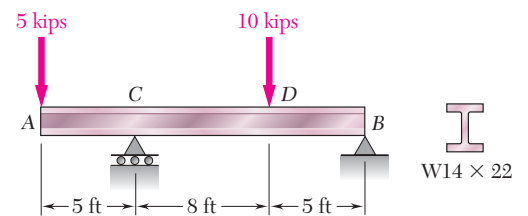

Fig. P5.25

5.26 Knowing that $W = 12$ kN, draw the shear and bending-moment diagrams for beam AB and determine the maximum normal stress due to bending.

5.27 Determine (a) the magnitude of the counterweight W for which the maximum absolute value of the bending moment in the beam is as small as possible, (b) the corresponding maximum normal stress due to bending. (*Hint:* Draw the bending-moment diagram and equate the absolute values of the largest positive and negative bending moments obtained.)

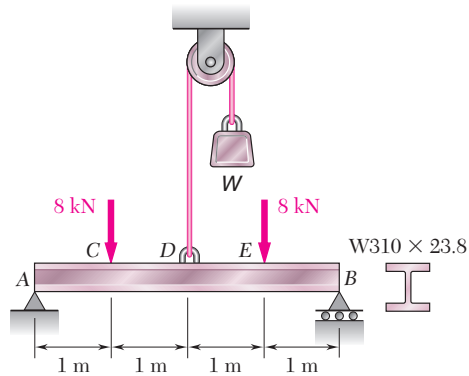

Fig. P5.26 and P5.27

5.28 Knowing that $P = Q = 480$ N, determine (a) the distance a for which the absolute value of the bending moment in the beam is as small as possible, (b) the corresponding maximum normal stress due to bending. (See hint of Prob. 5.27.)

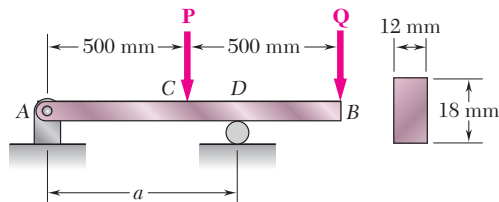

Fig. P5.28

5.29 Solve Prob. 5.28, assuming that $P = 480$ N and $Q = 320$ N.

5.30 Determine (a) the distance a for which the absolute value of the bending moment in the beam is as small as possible, (b) the corresponding maximum normal stress due to bending. (See hint of Prob. 5.27.)

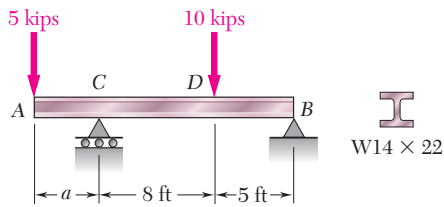

Fig. P5.30

5.31 Determine (a) the distance a for which the absolute value of the bending moment in the beam is as small as possible, (b) the corresponding maximum normal stress due to bending. (See hint of Prob. 5.27.)

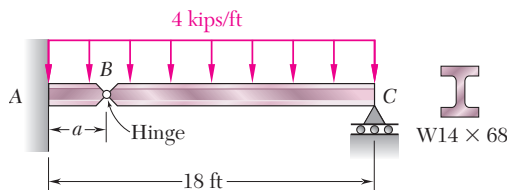

Fig. P5.31

5.32 A solid steel rod of diameter d is supported as shown. Knowing that for steel $\gamma = 490 \text{ lb/ft}^3$, determine the smallest diameter d that can be used if the normal stress due to bending is not to exceed 4 ksi.

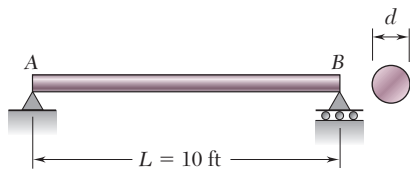

Fig. P5.32

5.33 A solid steel bar has a square cross section of side b and is supported as shown. Knowing that for steel $\rho = 7860 \text{ kg/m}^3$, determine the dimension b for which the maximum normal stress due to bending is (a) 10 MPa, (b) 50 MPa.

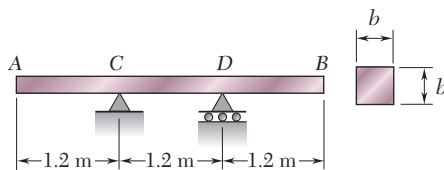

Fig. P5.33

5.3. RELATIONS AMONG LOAD, SHEAR, AND BENDING MOMENT

When a beam carries more than two or three concentrated loads, or when it carries distributed loads, the method outlined in Sec. 5.2 for plotting shear and bending moment can prove quite cumbersome. The construction of the shear diagram and, especially, of the bending-moment diagram will be greatly facilitated if certain relations existing among load, shear, and bending moment are taken into consideration.

Let us consider a simply supported beam AB carrying a distributed load w per unit length (Fig. 5.12a), and let C and C' be two points of the beam at a distance Δx from each other. The shear and bending moment at C will be denoted by V and M , respectively, and will be assumed positive; the shear and bending moment at C' will be denoted by $V + \Delta V$ and $M + \Delta M$.

We now detach the portion of beam CC' and draw its free-body diagram (Fig. 5.12b). The forces exerted on the free body include a load of magnitude $w \Delta x$ and internal forces and couples at C and C' . Since shear and bending moment have been assumed positive, the forces and couples will be directed as shown in the figure.

Relations between Load and Shear. Writing that the sum of the vertical components of the forces acting on the free body CC' is zero, we have

$$+\uparrow \Sigma F_y = 0: \quad V - (V + \Delta V) - w \Delta x = 0$$

$$\Delta V = -w \Delta x$$

Dividing both members of the equation by Δx and then letting Δx approach zero, we obtain

$$\frac{dV}{dx} = -w \quad (5.5)$$

Equation (5.5) indicates that, for a beam loaded as shown in Fig. 5.12a, the slope dV/dx of the shear curve is negative; the numerical value of the slope at any point is equal to the load per unit length at that point.

Integrating (5.5) between points C and D , we write

$$V_D - V_C = - \int_{x_C}^{x_D} w \, dx \quad (5.6)$$

$$V_D - V_C = -(\text{area under load curve between } C \text{ and } D) \quad (5.6')$$

Note that this result could also have been obtained by considering the equilibrium of the portion of beam CD , since the area under the load curve represents the total load applied between C and D .

It should be observed that Eq. (5.5) is not valid at a point where a concentrated load is applied; the shear curve is discontinuous at such a point, as seen in Sec. 5.2. Similarly, Eqs. (5.6) and (5.6') cease to be valid when concentrated loads are applied between C and D , since they do not take into account the sudden change in shear caused by a concentrated load. Equations (5.6) and (5.6'), therefore, should be applied only between successive concentrated loads.

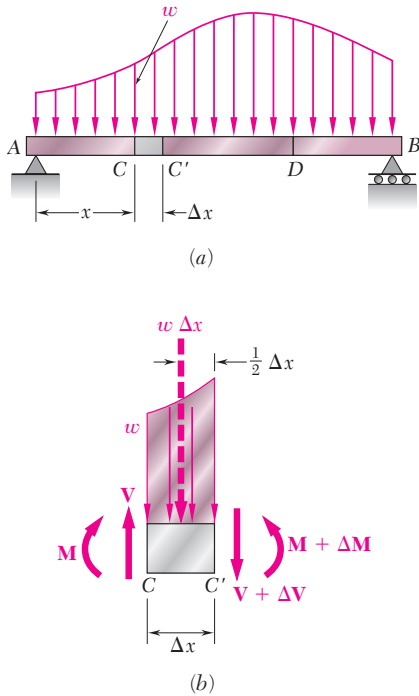

Fig. 5.12

Relations between Shear and Bending Moment. Returning to the free-body diagram of Fig. 5.12*b*, and writing now that the sum of the moments about C' is zero, we have

$$+\uparrow \Sigma M_{C'} = 0: \quad (M + \Delta M) - M - V \Delta x + w \Delta x \frac{\Delta x}{2} = 0$$

$$\Delta M = V \Delta x - \frac{1}{2} w (\Delta x)^2$$

Dividing both members of the equation by Δx and then letting Δx approach zero, we obtain

$$\frac{dM}{dx} = V \quad (5.7)$$

Equation (5.7) indicates that the slope dM/dx of the bending-moment curve is equal to the value of the shear. This is true at any point where the shear has a well-defined value, i.e., at any point where no concentrated load is applied. Equation (5.7) also shows that $V = 0$ at points where M is maximum. This property facilitates the determination of the points where the beam is likely to fail under bending.

Integrating (5.7) between points C and D , we write

$$M_D - M_C = \int_{x_C}^{x_D} V dx \quad (5.8)$$

$$M_D - M_C = \text{area under shear curve between } C \text{ and } D \quad (5.8')$$

Note that the area under the shear curve should be considered positive where the shear is positive and negative where the shear is negative. Equations (5.8) and (5.8') are valid even when concentrated loads are applied between C and D , as long as the shear curve has been correctly drawn. The equations cease to be valid, however, if a couple is applied at a point between C and D , since they do not take into account the sudden change in bending moment caused by a couple (see Sample Prob. 5.6).

EXAMPLE 5.03

Draw the shear and bending-moment diagrams for the simply supported beam shown in Fig. 5.13 and determine the maximum value of the bending moment.

From the free-body diagram of the entire beam, we determine the magnitude of the reactions at the supports.

$$R_A = R_B = \frac{1}{2} wL$$

Next, we draw the shear diagram. Close to the end A of the beam, the shear is equal to R_A , that is, to $\frac{1}{2} wL$, as we can check by considering as a free body a very small portion of the beam.

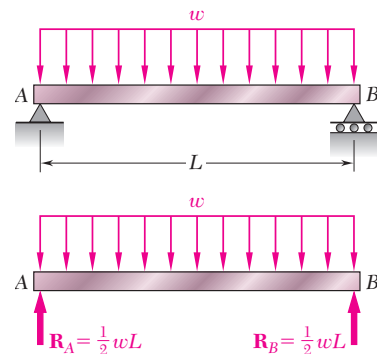

Fig. 5.13

Using Eq. (5.6), we then determine the shear V at any distance x from A ; we write

$$V - V_A = - \int_0^x w \, dx = -wx$$

$$V = V_A - wx = \frac{1}{2}wL - wx = w(\frac{1}{2}L - x)$$

The shear curve is thus an oblique straight line which crosses the x axis at $x = L/2$ (Fig. 5.14a). Considering, now, the bending moment, we first observe that $M_A = 0$. The value M of the bending moment at any distance x from A may then be obtained from Eq. (5.8); we have

$$M - M_A = \int_0^x V \, dx$$

$$M = \int_0^x w(\frac{1}{2}L - x) \, dx = \frac{1}{2}w(Lx - x^2)$$

The bending-moment curve is a parabola. The maximum value of the bending moment occurs when $x = L/2$, since V (and thus dM/dx) is zero for that value of x . Substituting $x = L/2$ in the last equation, we obtain $M_{\max} = wL^2/8$ (Fig. 5.14b).

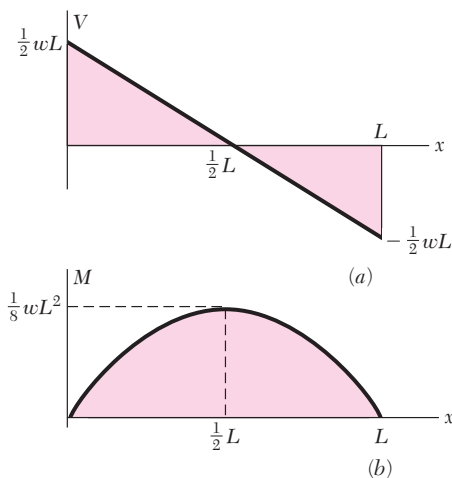
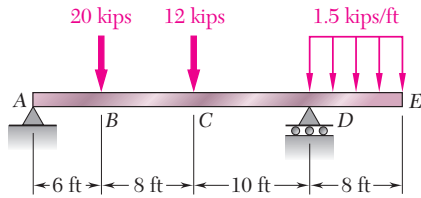

Fig. 5.14

In most engineering applications, one needs to know the value of the bending moment only at a few specific points. Once the shear diagram has been drawn, and after M has been determined at one of the ends of the beam, the value of the bending moment can then be obtained at any given point by computing the area under the shear curve and using Eq. (5.8'). For instance, since $M_A = 0$ for the beam of Example 5.03, the maximum value of the bending moment for that beam can be obtained simply by measuring the area of the shaded triangle in the shear diagram of Fig. 5.14a. We have

$$M_{\max} = \frac{1}{2} \frac{L}{2} \frac{wL}{2} = \frac{wL^2}{8}$$

We note that, in this example, the load curve is a horizontal straight line, the shear curve an oblique straight line, and the bending-moment curve a parabola. If the load curve had been an oblique straight line (first degree), the shear curve would have been a parabola (second degree) and the bending-moment curve a cubic (third degree). The shear and bending-moment curves will always be, respectively, one and two degrees higher than the load curve. With this in mind, we should be able to sketch the shear and bending-moment diagrams without actually determining the functions $V(x)$ and $M(x)$, once a few values of the shear and bending moment have been computed. The sketches obtained will be more accurate if we make use of the fact that, at any point where the curves are continuous, the slope of the shear curve is equal to $-w$ and the slope of the bending-moment curve is equal to V .



SAMPLE PROBLEM 5.3

Draw the shear and bending-moment diagrams for the beam and loading shown.

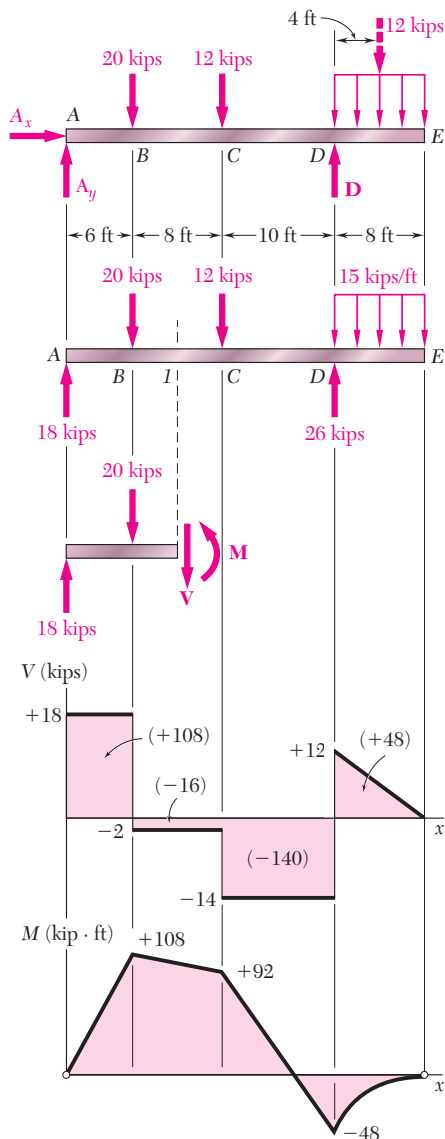

SOLUTION

Reactions. Considering the entire beam as a free body, we write

$$\begin{aligned}
 +\curvearrowright \sum M_A = 0: & \quad D(24 \text{ ft}) - (20 \text{ kips})(6 \text{ ft}) - (12 \text{ kips})(14 \text{ ft}) - (12 \text{ kips})(28 \text{ ft}) = 0 \\
 & \quad D = +26 \text{ kips} \qquad \mathbf{D} = 26 \text{ kips} \uparrow \\
 +\uparrow \sum F_y = 0: & \quad A_y - 20 \text{ kips} - 12 \text{ kips} + 26 \text{ kips} - 12 \text{ kips} = 0 \\
 & \quad A_y = +18 \text{ kips} \qquad \mathbf{A}_y = 18 \text{ kips} \uparrow \\
 \rightarrow \sum F_x = 0: & \quad A_x = 0 \qquad \mathbf{A}_x = 0
 \end{aligned}$$

We also note that at both A and E the bending moment is zero; thus, two points (indicated by dots) are obtained on the bending-moment diagram.

Shear Diagram. Since $dV/dx = -w$, we find that between concentrated loads and reactions the slope of the shear diagram is zero (i.e., the shear is constant). The shear at any point is determined by dividing the beam into two parts and considering either part as a free body. For example, using the portion of beam to the left of section I , we obtain the shear between B and C :

$$+\uparrow \sum F_y = 0: \quad +18 \text{ kips} - 20 \text{ kips} - V = 0 \qquad V = -2 \text{ kips}$$

We also find that the shear is $+12$ kips just to the right of D and zero at end E . Since the slope $dV/dx = -w$ is constant between D and E , the shear diagram between these two points is a straight line.

Bending-Moment Diagram. We recall that the area under the shear curve between two points is equal to the change in bending moment between the same two points. For convenience, the area of each portion of the shear diagram is computed and is indicated in parentheses on the diagram. Since the bending moment M_A at the left end is known to be zero, we write

$$\begin{aligned}
 M_B - M_A &= +108 & M_B &= +108 \text{ kip} \cdot \text{ft} \\
 M_C - M_B &= -16 & M_C &= +92 \text{ kip} \cdot \text{ft} \\
 M_D - M_C &= -140 & M_D &= -48 \text{ kip} \cdot \text{ft} \\
 M_E - M_D &= +48 & M_E &= 0
 \end{aligned}$$

Since M_E is known to be zero, a check of the computations is obtained.

Between the concentrated loads and reactions the shear is constant; thus, the slope dM/dx is constant and the bending-moment diagram is drawn by connecting the known points with straight lines. Between D and E where the shear diagram is an oblique straight line, the bending-moment diagram is a parabola.

From the V and M diagrams we note that $V_{\max} = 18$ kips and $M_{\max} = 108 \text{ kip} \cdot \text{ft}$.

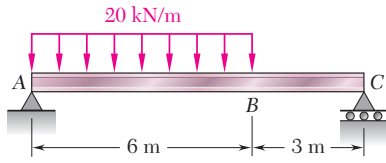

SAMPLE PROBLEM 5.4

The W360 × 79 rolled-steel beam AC is simply supported and carries the uniformly distributed load shown. Draw the shear and bending-moment diagrams for the beam and determine the location and magnitude of the maximum normal stress due to bending.

SOLUTION

Reactions. Considering the entire beam as a free body, we find

$$\mathbf{R}_A = 80 \text{ kN } \uparrow \quad \mathbf{R}_C = 40 \text{ kN } \uparrow$$

Shear Diagram. The shear just to the right of A is $V_A = +80 \text{ kN}$. Since the change in shear between two points is equal to *minus* the area under the load curve between the same two points, we obtain V_B by writing

$$\begin{aligned} V_B - V_A &= -(20 \text{ kN/m})(6 \text{ m}) = -120 \text{ kN} \\ V_B &= -120 + V_A = -120 + 80 = -40 \text{ kN} \end{aligned}$$

The slope $dV/dx = -w$ being constant between A and B, the shear diagram between these two points is represented by a straight line. Between B and C, the area under the load curve is zero; therefore,

$$V_C - V_B = 0 \quad V_C = V_B = -40 \text{ kN}$$

and the shear is constant between B and C.

Bending-Moment Diagram. We note that the bending moment at each end of the beam is zero. In order to determine the maximum bending moment, we locate the section D of the beam where $V = 0$. We write

$$\begin{aligned} V_D - V_A &= -wx \\ 0 - 80 \text{ kN} &= -(20 \text{ kN/m})x \end{aligned}$$

and, solving for x :

$$x = 4 \text{ m} \quad \blacktriangleleft$$

The maximum bending moment occurs at point D, where we have $dM/dx = V = 0$. The areas of the various portions of the shear diagram are computed and are given (in parentheses) on the diagram. Since the area of the shear diagram between two points is equal to the change in bending moment between the same two points, we write

$$\begin{aligned} M_D - M_A &= +160 \text{ kN} \cdot \text{m} & M_D &= +160 \text{ kN} \cdot \text{m} \\ M_B - M_D &= -40 \text{ kN} \cdot \text{m} & M_B &= +120 \text{ kN} \cdot \text{m} \\ M_C - M_B &= -120 \text{ kN} \cdot \text{m} & M_C &= 0 \end{aligned}$$

The bending-moment diagram consists of an arc of parabola followed by a segment of straight line; the slope of the parabola at A is equal to the value of V at that point.

Maximum Normal Stress. It occurs at D, where $|M|$ is largest. From Appendix C we find that for a W360 × 79 rolled-steel shape, $S = 1280 \text{ mm}^3$ about a horizontal axis. Substituting this value and $|M| = |M_D| = 160 \times 10^3 \text{ N} \cdot \text{m}$ into Eq. (5.3), we write

$$\sigma_m = \frac{|M_D|}{S} = \frac{160 \times 10^3 \text{ N} \cdot \text{m}}{1280 \times 10^{-6} \text{ m}^3} = 125.0 \times 10^6 \text{ Pa}$$

Maximum normal stress in the beam = 125.0 MPa \blacktriangleleft

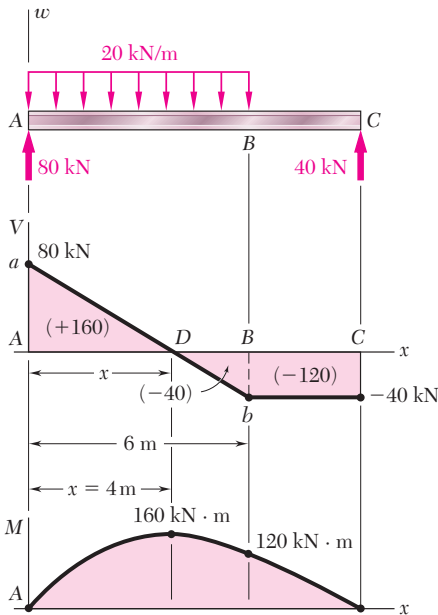

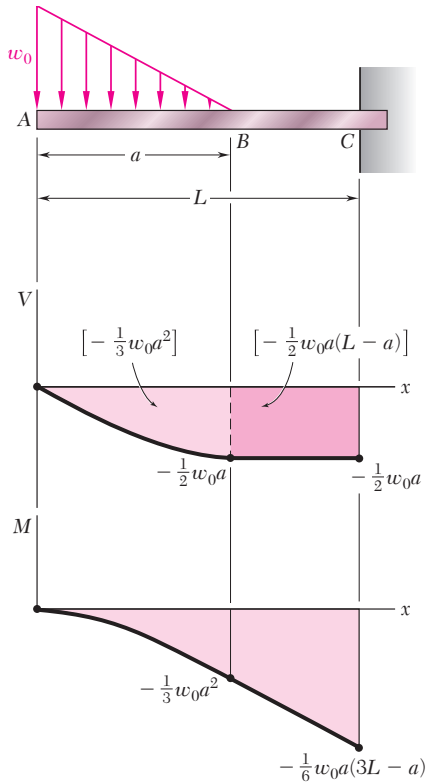

SAMPLE PROBLEM 5.5

Sketch the shear and bending-moment diagrams for the cantilever beam shown.

SOLUTION

Shear Diagram. At the free end of the beam, we find $V_A = 0$. Between A and B , the area under the load curve is $\frac{1}{2}w_0a$; we find V_B by writing

$$V_B - V_A = -\frac{1}{2}w_0a \quad V_B = -\frac{1}{2}w_0a$$

Between B and C , the beam is not loaded; thus $V_C = V_B$. At A , we have $w = w_0$ and, according to Eq. (5.5), the slope of the shear curve is $dV/dx = -w_0$, while at B the slope is $dV/dx = 0$. Between A and B , the loading decreases linearly, and the shear diagram is parabolic. Between B and C , $w = 0$, and the shear diagram is a horizontal line.

Bending-Moment Diagram. The bending moment M_A at the free end of the beam is zero. We compute the area under the shear curve and write

$$\begin{aligned} M_B - M_A &= -\frac{1}{3}w_0a^2 & M_B &= -\frac{1}{3}w_0a^2 \\ M_C - M_B &= -\frac{1}{2}w_0a(L - a) \\ M_C &= -\frac{1}{6}w_0a(3L - a) \end{aligned}$$

The sketch of the bending-moment diagram is completed by recalling that $dM/dx = V$. We find that between A and B the diagram is represented by a cubic curve with zero slope at A , and between B and C by a straight line.

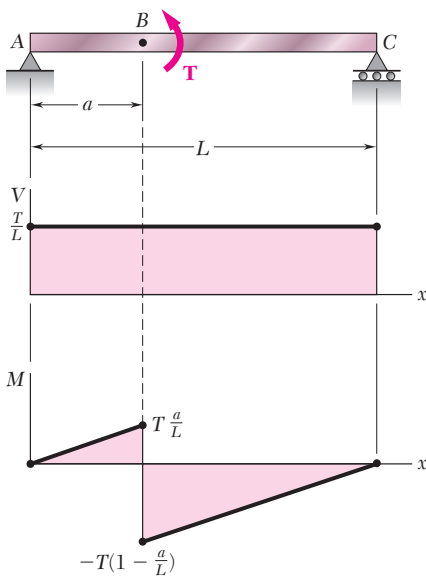

SAMPLE PROBLEM 5.6

The simple beam AC is loaded by a couple of moment T applied at point B . Draw the shear and bending-moment diagrams of the beam.

SOLUTION

The entire beam is taken as a free body, and we obtain

$$\mathbf{R}_A = \frac{T}{L} \uparrow \quad \mathbf{R}_C = \frac{T}{L} \downarrow$$

The shear at any section is constant and equal to T/L . Since a couple is applied at B , the bending-moment diagram is discontinuous at B ; it is represented by two oblique straight lines and decreases suddenly at B by an amount equal to T .

PROBLEMS

- 5.34** Using the method of Sec. 5.3, solve Prob. 5.1a.
- 5.35** Using the method of Sec. 5.3, solve Prob. 5.2a.
- 5.36** Using the method of Sec. 5.3, solve Prob. 5.3a.
- 5.37** Using the method of Sec. 5.3, solve Prob. 5.4a.
- 5.38** Using the method of Sec. 5.3, solve Prob. 5.5a.
- 5.39** Using the method of Sec. 5.3, solve Prob. 5.6a.
- 5.40** Using the method of Sec. 5.3, solve Prob. 5.7.
- 5.41** Using the method of Sec. 5.3, solve Prob. 5.8.
- 5.42** Using the method of Sec. 5.3, solve Prob. 5.9.
- 5.43** Using the method of Sec. 5.3, solve Prob. 5.10.

5.44 and 5.45 Draw the shear and bending-moment diagrams for the beam and loading shown, and determine the maximum absolute value (a) of the shear, (b) of the bending moment.

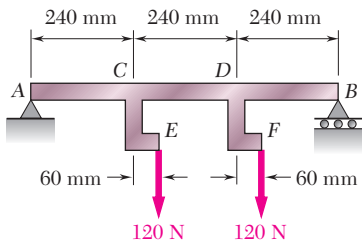

Fig. P5.44

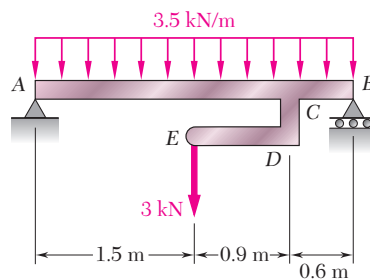

Fig. P5.45

- 5.46** Using the method of Sec. 5.3, solve Prob. 5.15.
- 5.47** Using the method of Sec. 5.3, solve Prob. 5.16.
- 5.48** Using the method of Sec. 5.3, solve Prob. 5.17.
- 5.49** Using the method of Sec. 5.3, solve Prob. 5.18.

5.50 and 5.51 Determine (a) the equations of the shear and bending-moment curves for the beam and loading shown, (b) the maximum absolute value of the bending moment in the beam.

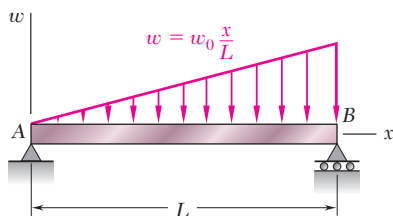

Fig. P5.50

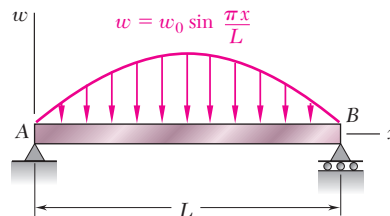

Fig. P5.51

5.52 For the beam and loading shown, determine the equations of the shear and bending-moment curves and the maximum absolute value of the bending moment in the beam, knowing that (a) $k = 1$, (b) $k = 0.5$.

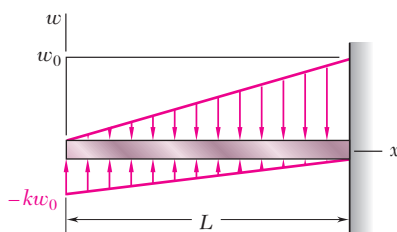

Fig. P5.52

5.53 Determine (a) the equations of the shear and bending-moment curves for the beam and loading shown, (b) the maximum absolute value of the bending moment in the beam.

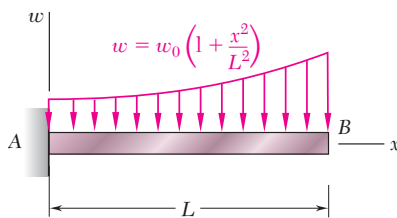

Fig. P5.53

5.54 and 5.55 Draw the shear and bending-moment diagrams for the beam and loading shown and determine the maximum normal stress due to bending.

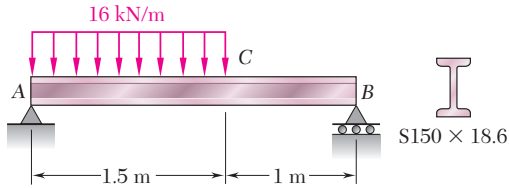

Fig. P5.54

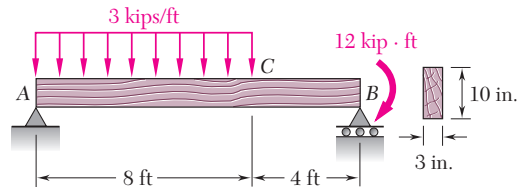

Fig. P5.55

5.56 and 5.57 Draw the shear and bending-moment diagrams for the beam and loading shown and determine the maximum normal stress due to bending.

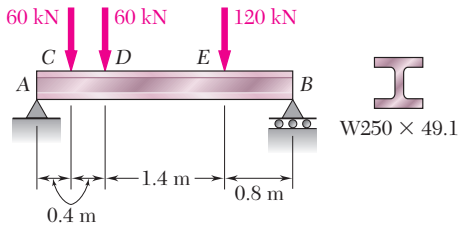

Fig. P5.56

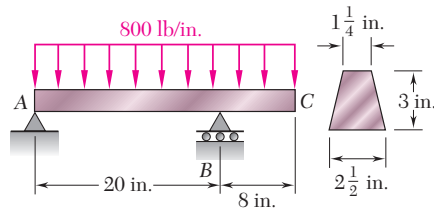

Fig. P5.57

5.58 and 5.59 Draw the shear and bending-moment diagrams for the beam and loading shown and determine the maximum normal stress due to bending.

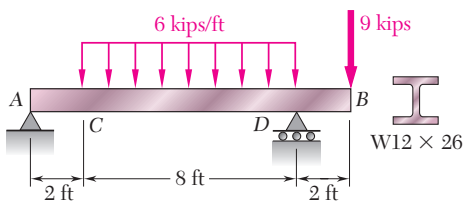

Fig. P5.58

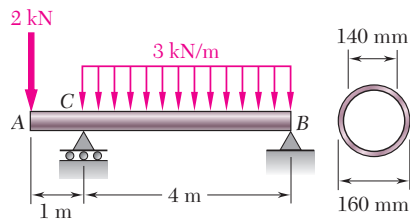

Fig. P5.59

5.60 and 5.61 Knowing that beam AB is in equilibrium under the loading shown, draw the shear and bending-moment diagrams and determine the maximum normal stress due to bending.

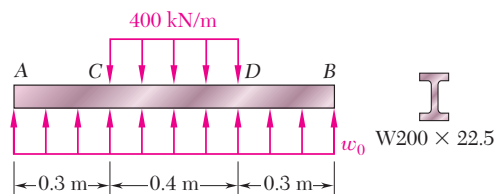

Fig. P5.60

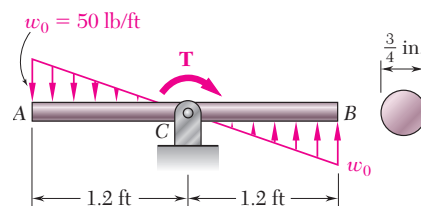

Fig. P5.61

***5.62** Beam AB supports a uniformly distributed load of 2 kN/m and two concentrated loads P and Q . It has been experimentally determined that the normal stress due to bending in the bottom edge of the beam is -56.9 MPa at A and -29.9 MPa at C . Draw the shear and bending-moment diagrams for the beam and determine the magnitudes of the loads P and Q .

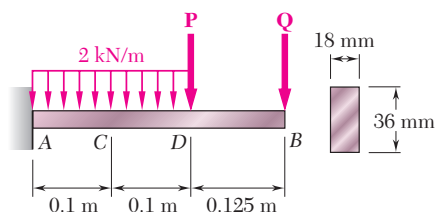

Fig. P5.62

***5.63** The beam AB supports two concentrated loads P and Q . The normal stress due to bending on the bottom edge of the beam is $+55\text{ MPa}$ at D and $+37.5\text{ MPa}$ at F . (a) Draw the shear and bending-moment diagrams for the beam. (b) Determine the maximum normal stress due to bending that occurs in the beam.

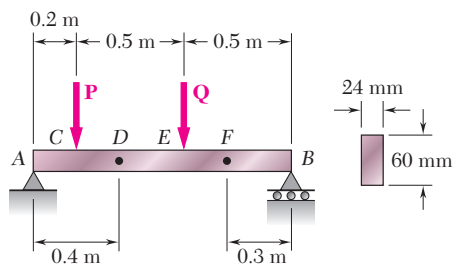

Fig. P5.63

***5.64** The beam AB supports a uniformly distributed load of 480 lb/ft and two concentrated loads P and Q . The normal stress due to bending on the bottom edge of the lower flange is +14.85 ksi at D and +10.65 ksi at E . (a) Draw the shear and bending-moment diagrams for the beam. (b) Determine the maximum normal stress due to bending that occurs in the beam.

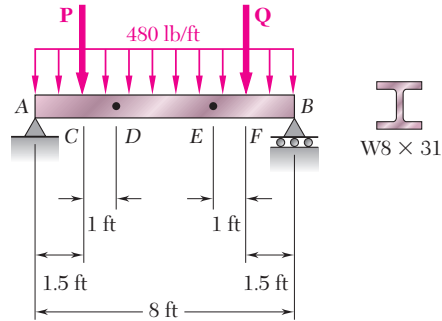

Fig. P5.64

5.4. DESIGN OF PRISMATIC BEAMS FOR BENDING

As indicated in Sec. 5.1, the design of a beam is usually controlled by the maximum absolute value $|M|_{\max}$ of the bending moment that will occur in the beam. The largest normal stress σ_m in the beam is found at the surface of the beam in the critical section where $|M|_{\max}$ occurs and can be obtained by substituting $|M|_{\max}$ for $|M|$ in Eq. (5.1) or Eq. (5.3).[†] We write

$$\sigma_m = \frac{|M|_{\max} c}{I} \quad \sigma_m = \frac{|M|_{\max}}{S} \quad (5.1', 5.3')$$

A safe design requires that $\sigma_m \leq \sigma_{\text{all}}$, where σ_{all} is the allowable stress for the material used. Substituting σ_{all} for σ_m in (5.3') and solving for S yields the minimum allowable value of the section modulus for the beam being designed:

$$S_{\min} = \frac{|M|_{\max}}{\sigma_{\text{all}}} \quad (5.9)$$

The design of common types of beams, such as timber beams of rectangular cross section and rolled-steel beams of various cross-sectional shapes, will be considered in this section. A proper procedure should lead to the most economical design. This means that, among beams of the same type and the same material, and other things being equal, the beam with the smallest weight per unit length—and, thus, the smallest cross-sectional area—should be selected, since this beam will be the least expensive.

[†]For beams that are not symmetrical with respect to their neutral surface, the largest of the distances from the neutral surface to the surfaces of the beam should be used for c in Eq. (5.1) and in the computation of the section modulus $S = I/c$.

The design procedure will include the following steps†:

1. First determine the value of σ_{all} for the material selected from a table of properties of materials or from design specifications. You can also compute this value by dividing the ultimate strength σ_U of the material by an appropriate factor of safety (Sec. 1.13). Assuming for the time being that the value of σ_{all} is the same in tension and in compression, proceed as follows.
2. Draw the shear and bending-moment diagrams corresponding to the specified loading conditions, and determine the maximum absolute value $|M|_{\text{max}}$ of the bending moment in the beam.
3. Determine from Eq. (5.9) the minimum allowable value S_{min} of the section modulus of the beam.
4. For a timber beam, the depth h of the beam, its width b , or the ratio h/b characterizing the shape of its cross section will probably have been specified. The unknown dimensions may then be selected by recalling from Eq. (4.19) of Sec. 4.4 that b and h must satisfy the relation $\frac{1}{6}bh^2 = S \geq S_{\text{min}}$.
5. For a rolled-steel beam, consult the appropriate table in Appendix C. Of the available beam sections, consider only those with a section modulus $S \geq S_{\text{min}}$ and select from this group the section with the smallest weight per unit length. This is the most economical of the sections for which $S \geq S_{\text{min}}$. Note that this is not necessarily the section with the smallest value of S (see Example 5.04). In some cases, the selection of a section may be limited by other considerations, such as the allowable depth of the cross section, or the allowable deflection of the beam (cf. Chap. 9).

The foregoing discussion was limited to materials for which σ_{all} is the same in tension and in compression. If σ_{all} is different in tension and in compression, you should make sure to select the beam section in such a way that $\sigma_m \leq \sigma_{\text{all}}$ for both tensile and compressive stresses. If the cross section is not symmetric about its neutral axis, the largest tensile and the largest compressive stresses will not necessarily occur in the section where $|M|$ is maximum. One may occur where M is maximum and the other where M is minimum. Thus, step 2 should include the determination of both M_{max} and M_{min} , and step 3 should be modified to take into account both tensile and compressive stresses.

Finally, keep in mind that the design procedure described in this section takes into account only the normal stresses occurring on the surface of the beam. Short beams, especially those made of timber, may fail in shear under a transverse loading. The determination of shearing stresses in beams will be discussed in Chap. 6. Also, in the case of rolled-steel beams, normal stresses larger than those considered here may occur at the junction of the web with the flanges. This will be discussed in Chap. 8.

†We assume that all beams considered in this chapter are adequately braced to prevent lateral buckling, and that bearing plates are provided under concentrated loads applied to rolled-steel beams to prevent local buckling (crippling) of the web.

EXAMPLE 5.04

Select a wide-flange beam to support the 15-kip load as shown in Fig. 5.15. The allowable normal stress for the steel used is 24 ksi.

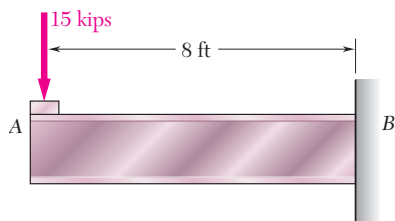

Fig. 5.15

1. The allowable normal stress is given: $\sigma_{\text{all}} = 24$ ksi.
2. The shear is constant and equal to 15 kips. The bending moment is maximum at B . We have

$$|M|_{\text{max}} = (15 \text{ kips})(8 \text{ ft}) = 120 \text{ kip} \cdot \text{ft} = 1440 \text{ kip} \cdot \text{in.}$$

3. The minimum allowable section modulus is

$$S_{\text{min}} = \frac{|M|_{\text{max}}}{\sigma_{\text{all}}} = \frac{1440 \text{ kip} \cdot \text{in.}}{24 \text{ ksi}} = 60.0 \text{ in}^3$$

4. Referring to the table of *Properties of Rolled-Steel Shapes* in Appendix C, we note that the shapes are arranged in groups of the same depth and that in each group they are listed in order of decreasing weight. We choose in each group the lightest beam having a section modulus $S = I/c$ at least as large as S_{min} and record the results in the following table.

Shape	S , in ³
W21 × 44	81.6
W18 × 50	88.9
W16 × 40	64.7
W14 × 43	62.7
W12 × 50	64.7
W10 × 54	60.0

The most economical is the W16 × 40 shape since it weighs only 40 lb/ft, even though it has a larger section modulus than two of the other shapes. We also note that the total weight of the beam will be $(8 \text{ ft}) \times (40 \text{ lb}) = 320 \text{ lb}$. This weight is small compared to the 15,000-lb load and can be neglected in our analysis.

***Load and Resistance Factor Design.** This alternative method of design was briefly described in Sec. 1.13 and applied to members under axial loading. It can readily be applied to the design of beams in bending. Replacing in Eq. (1.26) the loads P_D , P_L , and P_U , respectively, by the bending moments M_D , M_L , and M_U , we write

$$\gamma_D M_D + \gamma_L M_L \leq \phi M_U \quad (5.10)$$

The coefficients γ_D and γ_L are referred to as the *load factors* and the coefficient ϕ as the *resistance factor*. The moments M_D and M_L are the bending moments due, respectively, to the dead and the live loads, while M_U is equal to the product of the ultimate strength σ_U of the material and the section modulus S of the beam: $M_U = S\sigma_U$.

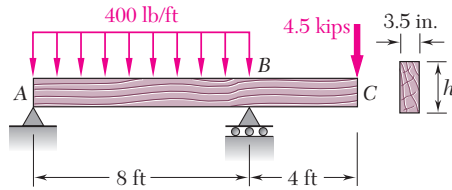

SAMPLE PROBLEM 5.7

A 12-ft-long overhanging timber beam AC with an 8-ft span AB is to be designed to support the distributed and concentrated loads shown. Knowing that timber of 4-in. nominal width (3.5-in. actual width) with a 1.75-ksi allowable stress is to be used, determine the minimum required depth h of the beam.

SOLUTION

Reactions. Considering the entire beam as a free body, we write

$$+\uparrow \Sigma M_A = 0: B(8 \text{ ft}) - (3.2 \text{ kips})(4 \text{ ft}) - (4.5 \text{ kips})(12 \text{ ft}) = 0$$

$$B = 8.35 \text{ kips} \quad \mathbf{B} = 8.35 \text{ kips} \uparrow$$

$$\pm \Sigma F_x = 0: \quad A_x = 0$$

$$+\uparrow \Sigma F_y = 0: A_y + 8.35 \text{ kips} - 3.2 \text{ kips} - 4.5 \text{ kips} = 0$$

$$A_y = -0.65 \text{ kips} \quad \mathbf{A} = 0.65 \text{ kips} \downarrow$$

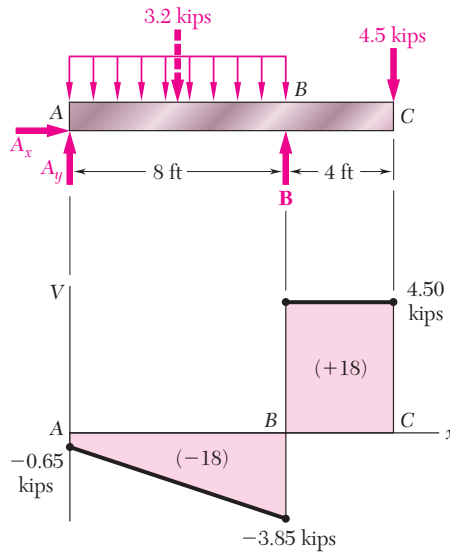

Shear Diagram. The shear just to the right of A is $V_A = A_y = -0.65$ kips. Since the change in shear between A and B is equal to *minus* the area under the load curve between these two points, we obtain V_B by writing

$$V_B - V_A = -(400 \text{ lb/ft})(8 \text{ ft}) = -3200 \text{ lb} = -3.20 \text{ kips}$$

$$V_B = V_A - 3.20 \text{ kips} = -0.65 \text{ kips} - 3.20 \text{ kips} = -3.85 \text{ kips.}$$

The reaction at B produces a sudden increase of 8.35 kips in V , resulting in a value of the shear equal to 4.50 kips to the right of B . Since no load is applied between B and C , the shear remains constant between these two points.

Determination of $|M|_{\max}$. We first observe that the bending moment is equal to zero at both ends of the beam: $M_A = M_C = 0$. Between A and B the bending moment decreases by an amount equal to the area under the shear curve, and between B and C it increases by a corresponding amount. Thus, the maximum absolute value of the bending moment is $|M|_{\max} = 18.00 \text{ kip} \cdot \text{ft}$.

Minimum Allowable Section Modulus. Substituting into Eq. (5.9) the given value of σ_{all} and the value of $|M|_{\max}$ that we have found, we write

$$S_{\min} = \frac{|M|_{\max}}{\sigma_{\text{all}}} = \frac{(18 \text{ kip} \cdot \text{ft})(12 \text{ in./ft})}{1.75 \text{ ksi}} = 123.43 \text{ in}^3$$

Minimum Required Depth of Beam. Recalling the formula developed in part 4 of the design procedure described in Sec. 5.4 and substituting the values of b and S_{\min} , we have

$$\frac{1}{6} b h^2 \geq S_{\min} \quad \frac{1}{6} (3.5 \text{ in.}) h^2 \geq 123.43 \text{ in}^3 \quad h \geq 14.546 \text{ in.}$$

The minimum required depth of the beam is

$$h = 14.55 \text{ in.} \quad \blacktriangleleft$$

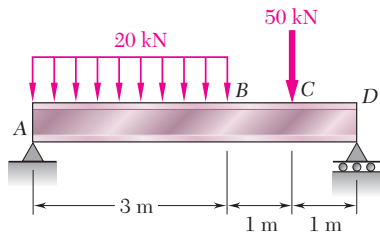

SAMPLE PROBLEM 5.8

A 5-m-long, simply supported steel beam AD is to carry the distributed and concentrated loads shown. Knowing that the allowable normal stress for the grade of steel to be used is 160 MPa, select the wide-flange shape that should be used.

SOLUTION

Reactions. Considering the entire beam as a free body, we write

$$+\uparrow \Sigma M_A = 0: D(5 \text{ m}) - (60 \text{ kN})(1.5 \text{ m}) - (50 \text{ kN})(4 \text{ m}) = 0$$

$$D = 58.0 \text{ kN} \quad \mathbf{D} = 58.0 \text{ kN} \uparrow$$

$$\pm \Sigma F_x = 0: A_x = 0$$

$$+\uparrow \Sigma F_y = 0: A_y + 58.0 \text{ kN} - 60 \text{ kN} - 50 \text{ kN} = 0$$

$$A_y = 52.0 \text{ kN} \quad \mathbf{A} = 52.0 \text{ kN} \uparrow$$

Shear Diagram. The shear just to the right of A is $V_A = A_y = +52.0 \text{ kN}$. Since the change in shear between A and B is equal to *minus* the area under the load curve between these two points, we have

$$V_B = 52.0 \text{ kN} - 60 \text{ kN} = -8 \text{ kN}$$

The shear remains constant between B and C , where it drops to -58 kN , and keeps this value between C and D . We locate the section E of the beam where $V = 0$ by writing

$$V_E - V_A = -wx$$

$$0 - 52.0 \text{ kN} = -(20 \text{ kN/m})x$$

Solving for x we find $x = 2.60 \text{ m}$.

Determination of $|M|_{\max}$. The bending moment is maximum at E , where $V = 0$. Since M is zero at the support A , its maximum value at E is equal to the area under the shear curve between A and E . We have, therefore, $|M|_{\max} = M_E = 67.6 \text{ kN} \cdot \text{m}$.

Minimum Allowable Section Modulus. Substituting into Eq. (5.9) the given value of σ_{all} and the value of $|M|_{\max}$ that we have found, we write

$$S_{\min} = \frac{|M|_{\max}}{\sigma_{\text{all}}} = \frac{67.6 \text{ kN} \cdot \text{m}}{160 \text{ MPa}} = 422.5 \times 10^{-6} \text{ m}^3 = 422.5 \times 10^3 \text{ mm}^3$$

Selection of Wide-Flange Shape. From Appendix C we compile a list of shapes that have a section modulus larger than S_{\min} and are also the lightest shape in a given depth group.

Shape	S , mm^3
W410 \times 38.8	637
W360 \times 32.9	474
W310 \times 38.7	549
W250 \times 44.8	535
W200 \times 46.1	448

We select the lightest shape available, namely

W360 \times 32.9 ◀

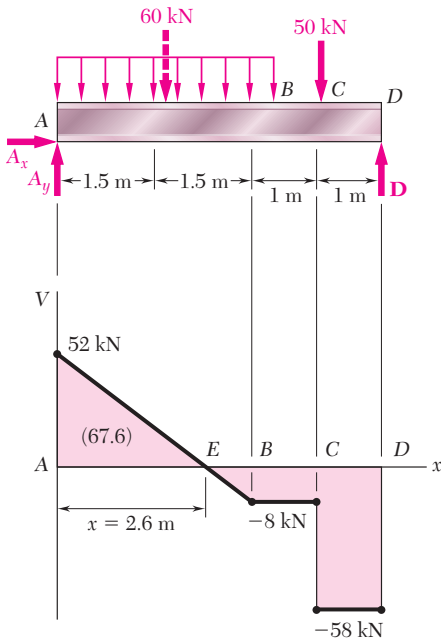

PROBLEMS

5.65 and 5.66 For the beam and loading shown, design the cross section of the beam, knowing that the grade of timber used has an allowable normal stress of 12 MPa.

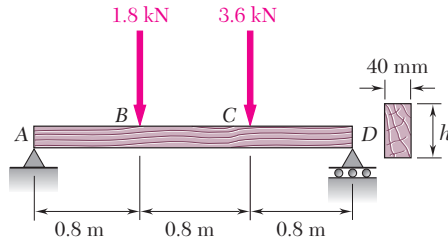

Fig. P5.65

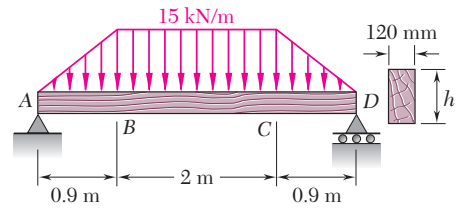

Fig. P5.66

5.67 and 5.68 For the beam and loading shown, design the cross section of the beam, knowing that the grade of timber used has an allowable normal stress of 1750 psi.

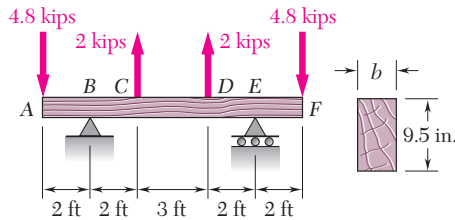

Fig. P5.67

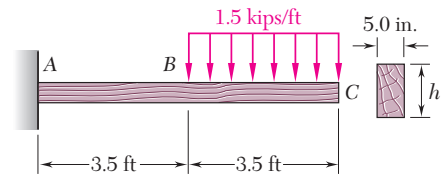

Fig. P5.68

5.69 and 5.70 For the beam and loading shown, design the cross section of the beam, knowing that the grade of timber used has an allowable normal stress of 12 MPa.

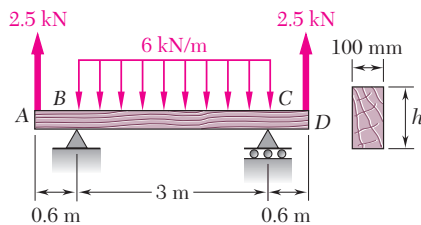

Fig. P5.69

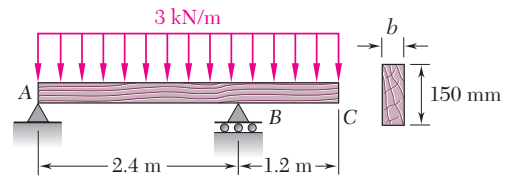

Fig. P5.70

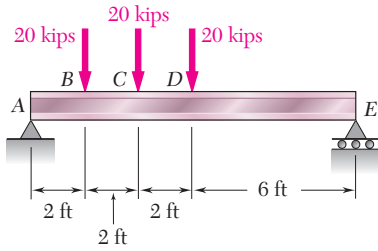

Fig. P5.71

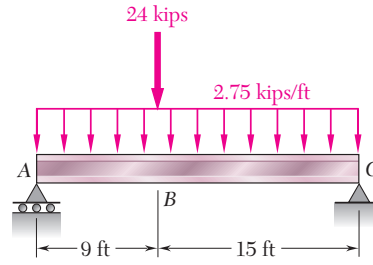

Fig. P5.72

5.71 and 5.72 Knowing that the allowable stress for the steel used is 24 ksi, select the most economical wide-flange beam to support the loading shown.

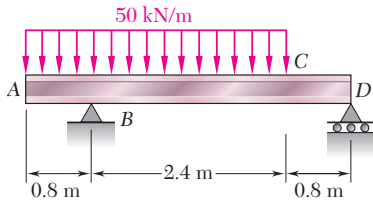

Fig. P5.73

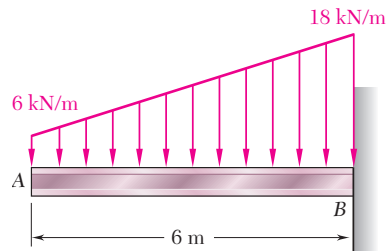

Fig. P5.74

5.73 and 5.74 Knowing that the allowable stress for the steel used is 160 MPa, select the most economical wide-flange beam to support the loading shown.

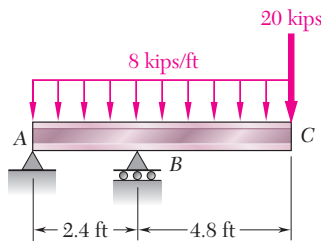

Fig. P5.75

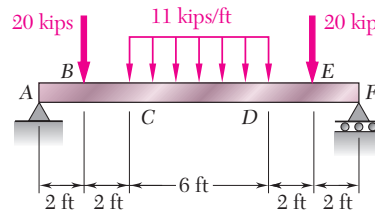

Fig. P5.76

5.75 and 5.76 Knowing that the allowable stress for the steel used is 24 ksi, select the most economical S-shape beam to support the loading shown.

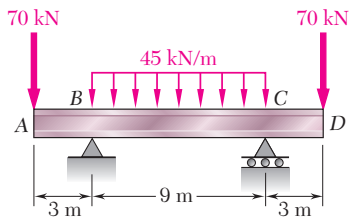

Fig. P5.77

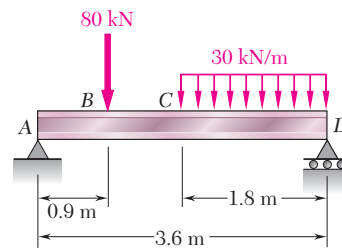

Fig. P5.78

5.77 and 5.78 Knowing that the allowable stress for the steel used is 160 MPa, select the most economical S-shape beam to support the loading shown.

5.79 A steel pipe of 4-in. diameter is to support the loading shown. Knowing that the stock of pipes available has thicknesses varying from $\frac{1}{4}$ in. to 1 in. in $\frac{1}{8}$ -in. increments, and that the allowable normal stress for the steel used is 24 ksi, determine the minimum wall thickness t that can be used.

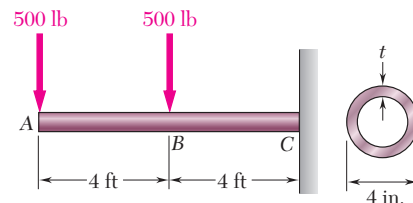

Fig. P5.79

5.80 Three steel plates are welded together to form the beam shown. Knowing that the allowable normal stress for the steel used is 22 ksi, determine the minimum flange width b that can be used.

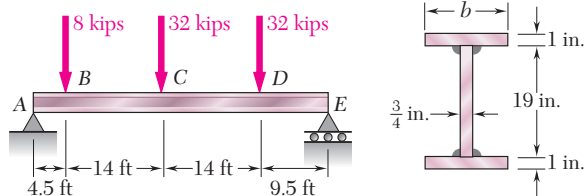

Fig. P5.80

5.81 Two metric rolled-steel channels are to be welded along their edges and used to support the loading shown. Knowing that the allowable normal stress for the steel used is 150 MPa, determine the most economical channels that can be used.

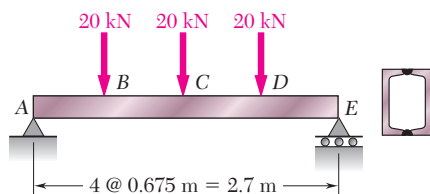

Fig. P5.81

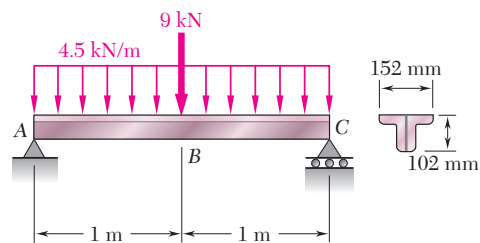

Fig. P5.82

5.82 Two L102 \times 76 rolled-steel angles are bolted together and used to support the loading shown. Knowing that the allowable normal stress for the steel used is 140 MPa, determine the minimum angle thickness that can be used.

5.83 Assuming the upward reaction of the ground to be uniformly distributed and knowing that the allowable normal stress for the steel used is 170 MPa, select the most economical wide-flange beam to support the loading shown.

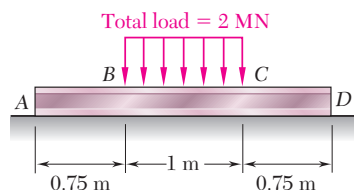

Fig. P5.83

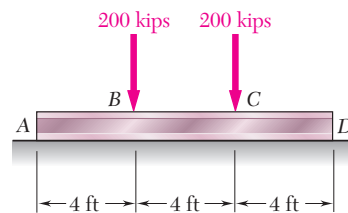

Fig. P5.84

5.84 Assuming the upward reaction of the ground to be uniformly distributed and knowing that the allowable normal stress for the steel used is 24 ksi, select the most economical wide-flange beam to support the loading shown.

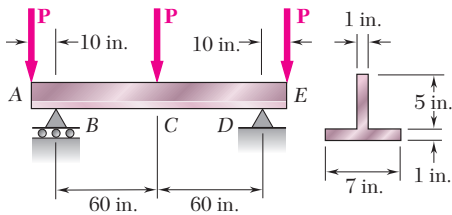

Fig. P5.87

5.85 Determine the largest permissible distributed load w for the beam shown, knowing that the allowable normal stress is $+80$ MPa in tension and -130 MPa in compression.

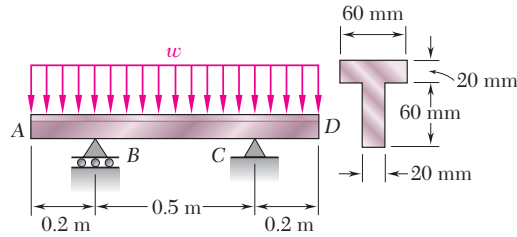

Fig. P5.85

5.86 Solve Prob. 5.85, assuming that the cross section of the beam is reversed, with the flange of the beam resting on the supports at B and C .

5.87 Determine the allowable value of P for the loading shown, knowing that the allowable normal stress is $+8$ ksi in tension and -18 ksi in compression.

5.88 Solve Prob. 5.87, assuming that the T-shaped beam is inverted.

5.89 Beams AB , BC , and CD have the cross section shown and are pin-connected at B and C . Knowing that the allowable normal stress is $+110$ MPa in tension and -150 MPa in compression, determine (a) the largest permissible value of w if beam BC is not to be overstressed, (b) the corresponding maximum distance a for which the cantilever beams AB and CD are not overstressed.

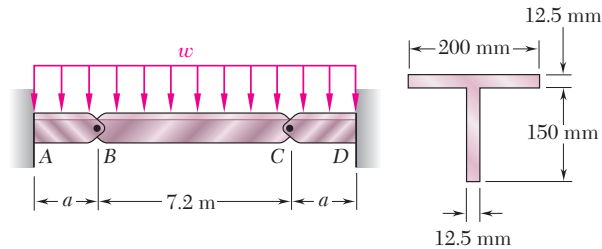

Fig. P5.89

5.90 Beams AB , BC , and CD have the cross section shown and are pin-connected at B and C . Knowing that the allowable normal stress is $+110$ MPa in tension and -150 MPa in compression, determine (a) the largest permissible value of P if beam BC is not to be overstressed, (b) the corresponding maximum distance a for which the cantilever beams AB and CD are not overstressed.

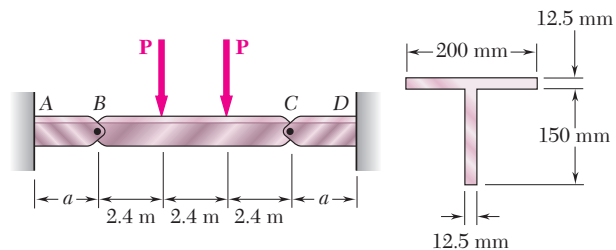

Fig. P5.90

5.91 A 240-kN load is to be supported at the center of the 5-m span shown. Knowing that the allowable normal stress for the steel used is 165 MPa, determine (a) the smallest allowable length l of beam CD if the $W310 \times 74$ beam AB is not to be overstressed, (b) the most economical W shape that can be used for beam CD . Neglect the weight of both beams.

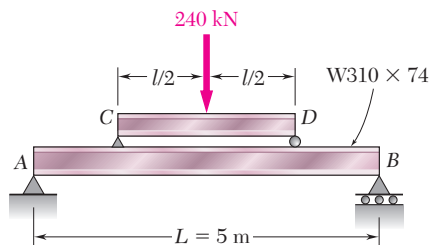

Fig. P5.91

5.92 Beam ABC is bolted to beams DBE and FCG . Knowing that the allowable normal stress is 24 ksi, select the most economical wide-flange shape that can be used (a) for beam ABC , (b) for beam DBE , (c) for beam FCG .

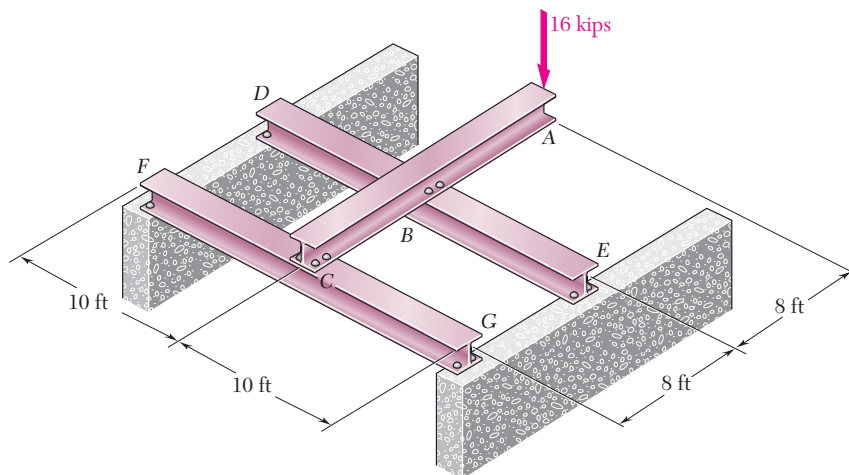

Fig. P5.92

5.93 A uniformly distributed load of 66 kN/m is to be supported over the 6-m span shown. Knowing that the allowable normal stress for the steel used is 140 MPa, determine (a) the smallest allowable length l of beam CD if the $W460 \times 74$ beam AB is not to be overstressed, (b) the most economical W shape that can be used for beam CD . Neglect the weight of both beams.

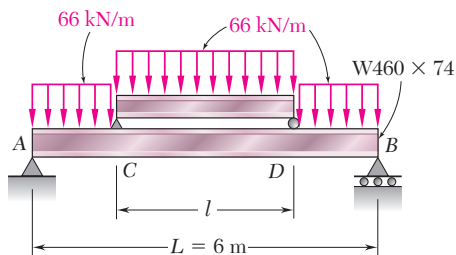

Fig. P5.93

***5.94** A roof structure consists of plywood and roofing material supported by several timber beams of length $L = 16$ m. The dead load carried by each beam, including the estimated weight of the beam, can be represented by a uniformly distributed load $w_D = 350$ N/m. The live load consists of a snow load, represented by a uniformly distributed load $w_L = 600$ N/m, and a 6-kN concentrated load \mathbf{P} applied at the midpoint C of each beam. Knowing that the ultimate strength for the timber used is $\sigma_U = 50$ MPa and that the width of the beam is $b = 75$ mm, determine the minimum allowable depth h of the beams, using LRFD with the load factors $\gamma_D = 1.2$, $\gamma_L = 1.6$ and the resistance factor $\phi = 0.9$.

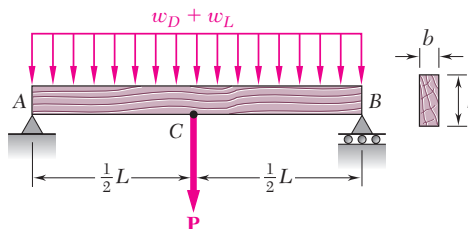

Fig. P5.94

***5.95** Solve Prob. 5.94, assuming that the 6-kN concentrated load \mathbf{P} applied to each beam is replaced by 3-kN concentrated loads \mathbf{P}_1 and \mathbf{P}_2 applied at a distance of 4 m from each end of the beams.

***5.96** A bridge of length $L = 48$ ft is to be built on a secondary road whose access to trucks is limited to two-axle vehicles of medium weight. It will consist of a concrete slab and of simply supported steel beams with an ultimate strength $\sigma_U = 60$ ksi. The combined weight of the slab and beams can be approximated by a uniformly distributed load $w = 0.75$ kips/ft on each beam. For the purpose of the design, it is assumed that a truck with axles located at a distance $a = 14$ ft from each other will be driven across the bridge and that the resulting concentrated loads \mathbf{P}_1 and \mathbf{P}_2 exerted on each beam could be as large as 24 kips and 6 kips, respectively. Determine the most economical wide-flange shape for the beams, using LRFD with the load factors $\gamma_D = 1.25$, $\gamma_L = 1.75$ and the resistance factor $\phi = 0.9$. [Hint: It can be shown that the maximum value of $|M_L|$ occurs under the larger load when that load is located to the left of the center of the beam at a distance equal to $aP_2/2(P_1 + P_2)$.]

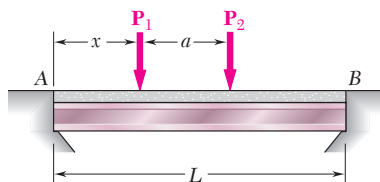

Fig. P5.96

***5.97** Assuming that the front and rear axle loads remain in the same ratio as for the truck of Prob. 5.96, determine how much heavier a truck could safely cross the bridge designed in that problem.

Reviewing the work done in the preceding sections, we note that the shear and bending moment could only rarely be described by single analytical functions. In the case of the cantilever beam of Example 5.02 (Fig. 5.10), which supported a uniformly distributed load w , the shear and bending moment *could* be represented by single analytical functions, namely, $V = -wx$ and $M = -\frac{1}{2}wx^2$; this was due to the fact that *no discontinuity* existed in the loading of the beam. On the other hand, in the case of the simply supported beam of Example 5.01, which was loaded only at its midpoint C , the load \mathbf{P} applied at C represented a *singularity* in the beam loading. This singularity resulted in discontinuities in the shear and bending moment and required the use of different analytical functions to represent V and M in the portions of beam located, respectively, to the left and to the right of point C . In Sample Prob. 5.2, the beam had to be divided into three portions, in each of which different functions were used to represent the shear and the bending moment. This situation led us to rely on the graphical representation of the functions V and M provided by the shear and bending-moment diagrams and, later in Sec. 5.3, on a graphical method of integration to determine V and M from the distributed load w .

The purpose of this section is to show how the use of *singularity functions* makes it possible to represent the shear V and the bending moment M by single mathematical expressions.

Consider the simply supported beam AB , of length $2a$, which carries a uniformly distributed load w_0 extending from its midpoint C to its right-hand support B (Fig. 5.16). We first draw the free-body diagram of the entire beam (Fig. 5.17a); replacing the distributed load by an equivalent concentrated load and, summing moments about B , we write

$$+\uparrow \sum M_B = 0: \quad (w_0 a)\left(\frac{1}{2}a\right) - R_A(2a) = 0 \quad R_A = \frac{1}{4}w_0 a$$

Next we cut the beam at a point D between A and C . From the free-body diagram of AD (Fig. 5.17b) we conclude that, over the interval $0 < x < a$, the shear and bending moment are expressed, respectively, by the functions

$$V_1(x) = \frac{1}{4}w_0 a \quad \text{and} \quad M_1(x) = \frac{1}{4}w_0 ax$$

Cutting, now, the beam at a point E between C and B , we draw the free-body diagram of portion AE (Fig. 5.17c). Replacing the distributed load by an equivalent concentrated load, we write

$$+\uparrow \sum F_y = 0: \quad \frac{1}{4}w_0 a - w_0(x - a) - V_2 = 0$$

$$+\uparrow \sum M_E = 0: \quad -\frac{1}{4}w_0 ax + w_0(x - a)\left[\frac{1}{2}(x - a)\right] + M_2 = 0$$

and conclude that, over the interval $a < x < 2a$, the shear and bending moment are expressed, respectively, by the functions

$$V_2(x) = \frac{1}{4}w_0 a - w_0(x - a) \quad \text{and} \quad M_2(x) = \frac{1}{4}w_0 ax - \frac{1}{2}w_0(x - a)^2$$

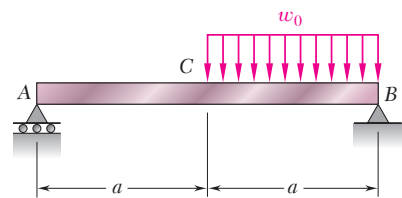

Fig. 5.16

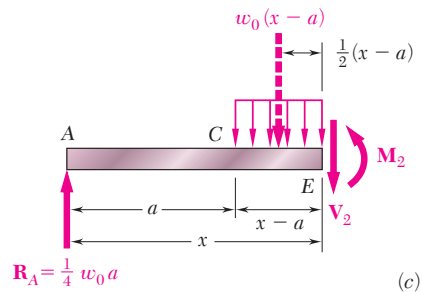
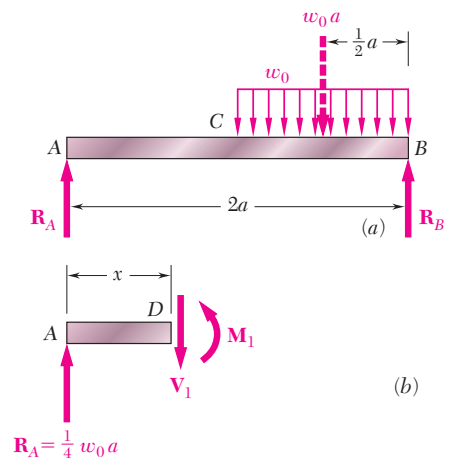

Fig. 5.17

As we pointed out earlier in this section, the fact that the shear and bending moment are represented by different functions of x , depending upon whether x is smaller or larger than a , is due to the discontinuity in the loading of the beam. However, the functions $V_1(x)$ and $V_2(x)$ can be represented by the single expression

$$V(x) = \frac{1}{4}w_0a - w_0\langle x - a \rangle \quad (5.11)$$

if we specify that the second term should be included in our computations when $x \geq a$ and ignored when $x < a$. In other words, *the brackets $\langle \rangle$ should be replaced by ordinary parentheses $()$ when $x \geq a$ and by zero when $x < a$* . With the same convention, the bending moment can be represented at any point of the beam by the single expression

$$M(x) = \frac{1}{4}w_0ax - \frac{1}{2}w_0\langle x - a \rangle^2 \quad (5.12)$$

From the convention we have adopted, it follows that brackets $\langle \rangle$ can be differentiated or integrated as ordinary parentheses. Instead of calculating the bending moment from free-body diagrams, we could have used the method indicated in Sec. 5.3 and integrated the expression obtained for $V(x)$:

$$M(x) - M(0) = \int_0^x V(x) dx = \int_0^x \frac{1}{4}w_0a dx - \int_0^x w_0\langle x - a \rangle dx$$

After integration, and observing that $M(0) = 0$, we obtain as before

$$M(x) = \frac{1}{4}w_0ax - \frac{1}{2}w_0\langle x - a \rangle^2$$

Furthermore, using the same convention again, we note that the distributed load at any point of the beam can be expressed as

$$w(x) = w_0\langle x - a \rangle^0 \quad (5.13)$$

Indeed, the brackets should be replaced by zero for $x < a$ and by parentheses for $x \geq a$; we thus check that $w(x) = 0$ for $x < a$ and, defining the zero power of any number as unity, that $\langle x - a \rangle^0 = (x - a)^0 = 1$ and $w(x) = w_0$ for $x \geq a$. From Sec. 5.3 we recall that the shear could have been obtained by integrating the function $-w(x)$. Observing that $V = \frac{1}{4}w_0a$ for $x = 0$, we write

$$V(x) - V(0) = - \int_0^x w(x) dx = - \int_0^x w_0\langle x - a \rangle^0 dx$$

$$V(x) - \frac{1}{4}w_0a = -w_0\langle x - a \rangle^1$$

Solving for $V(x)$ and dropping the exponent 1, we obtain again

$$V(x) = \frac{1}{4}w_0a - w_0\langle x - a \rangle$$

The expressions $\langle x - a \rangle^0$, $\langle x - a \rangle$, $\langle x - a \rangle^2$ are called *singularity functions*. By definition, we have, for $n \geq 0$,

$$\langle x - a \rangle^n = \begin{cases} (x - a)^n & \text{when } x \geq a \\ 0 & \text{when } x < a \end{cases} \quad (5.14)$$

We also note that whenever the quantity between brackets is positive or zero, the brackets should be replaced by ordinary parentheses, and whenever that quantity is negative, the bracket itself is equal to zero.

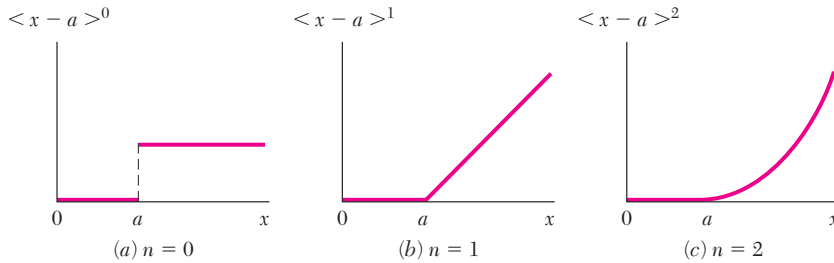

Fig. 5.18

The three singularity functions corresponding respectively to $n = 0$, $n = 1$, and $n = 2$ have been plotted in Fig. 5.18. We note that the function $\langle x - a \rangle^0$ is discontinuous at $x = a$ and is in the shape of a “step.” For that reason it is referred to as the *step function*. According to (5.14), and with the zero power of any number defined as unity, we have†

$$\langle x - a \rangle^0 = \begin{cases} 1 & \text{when } x \geq a \\ 0 & \text{when } x < a \end{cases} \quad (5.15)$$

It follows from the definition of singularity functions that

$$\int \langle x - a \rangle^n dx = \frac{1}{n + 1} \langle x - a \rangle^{n+1} \quad \text{for } n \geq 0 \quad (5.16)$$

and

$$\frac{d}{dx} \langle x - a \rangle^n = n \langle x - a \rangle^{n-1} \quad \text{for } n \geq 1 \quad (5.17)$$

Most of the beam loadings encountered in engineering practice can be broken down into the basic loadings shown in Fig. 5.19. Whenever applicable, the corresponding functions $w(x)$, $V(x)$, and $M(x)$ have been expressed in terms of singularity functions and plotted against a color background. A heavier color background was used to indicate for each loading the expression that is most easily derived or remembered and from which the other functions can be obtained by integration.

†Since $\langle x - a \rangle^0$ is discontinuous at $x = a$, it can be argued that this function should be left undefined for $x = a$ or that it should be assigned both of the values 0 and 1 for $x = a$. However, defining $\langle x - a \rangle^0$ as equal to 1 when $x = a$, as stated in (5.15), has the advantage of being unambiguous and, thus, readily applicable to computer programming (cf. page 348).

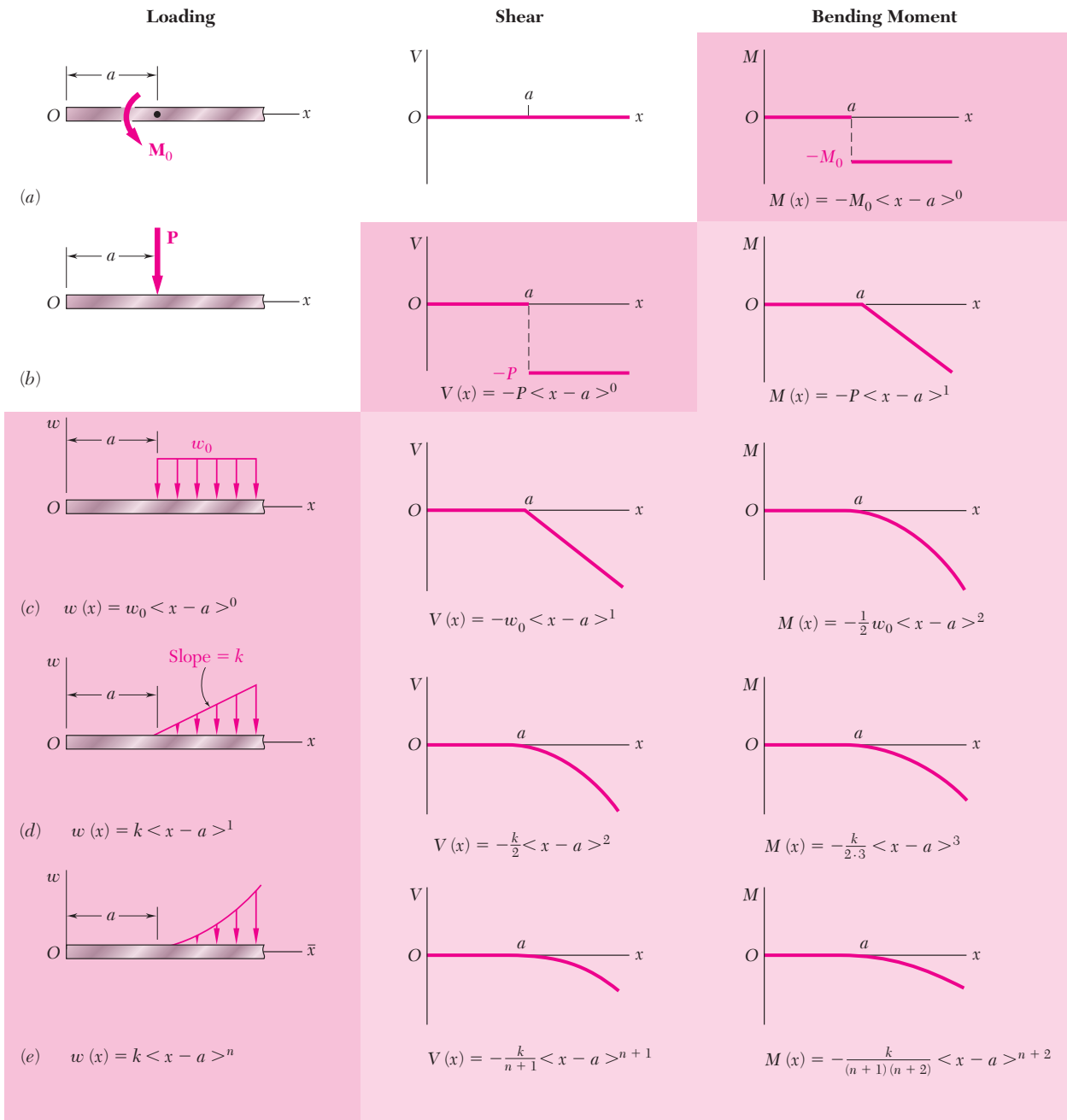

Fig. 5.19 Basic loadings and corresponding shears and bending moments expressed in terms of singularity functions.

After a given beam loading has been broken down into the basic loadings of Fig. 5.19, the functions $V(x)$ and $M(x)$ representing the shear and bending moment at any point of the beam can be obtained by adding the corresponding functions associated with each of the basic loadings and reactions. Since all the distributed loadings shown in Fig. 5.19 are

open-ended to the right, a distributed loading that does not extend to the right end of the beam or that is discontinuous should be replaced as shown in Fig. 5.20 by an equivalent combination of open-ended loadings. (See also Example 5.05 and Sample Prob. 5.9.)

As you will see in Sec. 9.6, the use of singularity functions also greatly simplifies the determination of beam deflections. It was in connection with that problem that the approach used in this section was first suggested in 1862 by the German mathematician A. Clebsch (1833–1872). However, the British mathematician and engineer W. H. Macaulay (1853–1936) is usually given credit for introducing the singularity functions in the form used here, and the brackets $\langle \ \rangle$ are generally referred to as *Macaulay's brackets*.[†]

[†]W. H. Macaulay, "Note on the Deflection of Beams," *Messenger of Mathematics*, vol. 48, pp. 129–130, 1919.

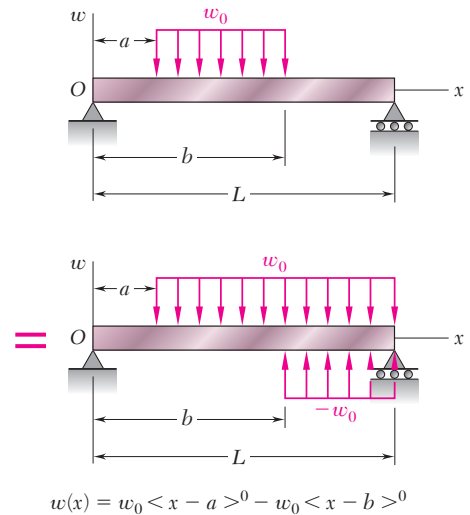

Fig. 5.20

$$w(x) = w_0 \langle x - a \rangle^0 - w_0 \langle x - b \rangle^0$$

EXAMPLE 5.05

For the beam and loading shown (Fig. 5.21a) and using singularity functions, express the shear and bending moment as functions of the distance x from the support at A.

We first determine the reaction at A by drawing the free-body diagram of the beam (Fig. 5.21b) and writing

$$\rightarrow \Sigma F_x = 0: \quad A_x = 0$$

$$\begin{aligned} +\uparrow \Sigma M_B = 0: \quad & -A_y(3.6 \text{ m}) + (1.2 \text{ kN})(3 \text{ m}) \\ & + (1.8 \text{ kN})(2.4 \text{ m}) + 1.44 \text{ kN} \cdot \text{m} = 0 \\ & A_y = 2.60 \text{ kN} \end{aligned}$$

Next, we replace the given distributed loading by two equivalent open-ended loadings (Fig. 5.21c) and express the distributed load $w(x)$ as the sum of the corresponding step functions:

$$w(x) = +w_0 \langle x - 0.6 \rangle^0 - w_0 \langle x - 1.8 \rangle^0$$

The function $V(x)$ is obtained by integrating $w(x)$, reversing the + and - signs, and adding to the result the constants A_y and $-P \langle x - 0.6 \rangle^0$ representing the respective contributions to the shear of the reaction at A and of the concentrated load. (No other constant of integration is required.) Since the concentrated couple does not directly affect the shear, it should be ignored in this computation. We write

$$V(x) = -w_0 \langle x - 0.6 \rangle^1 + w_0 \langle x - 1.8 \rangle^1 + A_y - P \langle x - 0.6 \rangle^0$$

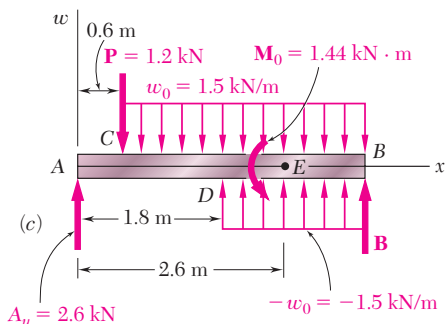
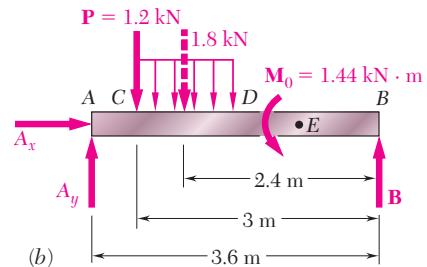
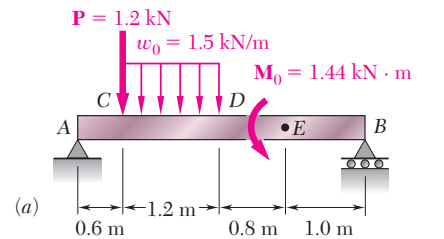
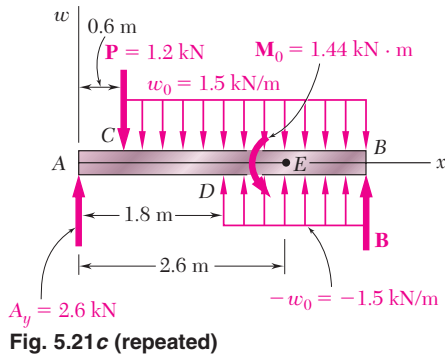

Fig. 5.21



In a similar way, the function $M(x)$ is obtained by integrating $V(x)$ and adding to the result the constant $-M_0\langle x - 2.6 \rangle^0$ representing the contribution of the concentrated couple to the bending moment. We have

$$M(x) = -\frac{1}{2}w_0\langle x - 0.6 \rangle^2 + \frac{1}{2}w_0\langle x - 1.8 \rangle^2 + A_y x - P\langle x - 0.6 \rangle^1 - M_0\langle x - 2.6 \rangle^0$$

Substituting the numerical values of the reaction and loads into the expressions obtained for $V(x)$ and $M(x)$ and being careful *not* to compute any product or expand any square involving a bracket, we obtain the following expressions for the shear and bending moment at any point of the beam:

$$V(x) = -1.5\langle x - 0.6 \rangle^1 + 1.5\langle x - 1.8 \rangle^1 + 2.6 - 1.2\langle x - 0.6 \rangle^0$$

$$M(x) = -0.75\langle x - 0.6 \rangle^2 + 0.75\langle x - 1.8 \rangle^2 + 2.6x - 1.2\langle x - 0.6 \rangle^1 - 1.44\langle x - 2.6 \rangle^0$$

EXAMPLE 5.06

For the beam and loading of Example 5.05, determine the numerical values of the shear and bending moment at the midpoint D .

Making $x = 1.8$ m in the expressions found for $V(x)$ and $M(x)$ in Example 5.05, we obtain

$$V(1.8) = -1.5\langle 1.2 \rangle^1 + 1.5\langle 0 \rangle^1 + 2.6 - 1.2\langle 1.2 \rangle^0$$

$$M(1.8) = -0.75\langle 1.2 \rangle^2 + 0.75\langle 0 \rangle^2 + 2.6(1.8) - 1.2\langle 1.2 \rangle^1 - 1.44\langle -0.8 \rangle^0$$

Recalling that whenever a quantity between brackets is positive or zero, the brackets should be replaced by ordinary parentheses, and whenever the quantity is negative, the bracket itself is equal to zero, we write

$$V(1.8) = -1.5(1.2)^1 + 1.5(0)^1 + 2.6 - 1.2(1.2)^0$$

$$= -1.5(1.2) + 1.5(0) + 2.6 - 1.2(1)$$

$$= -1.8 + 0 + 2.6 - 1.2$$

$$V(1.8) = -0.4 \text{ kN}$$

and

$$M(1.8) = -0.75(1.2)^2 + 0.75(0)^2 + 2.6(1.8) - 1.2(1.2)^1 - 1.44(0)$$

$$= -1.08 + 0 + 4.68 - 1.44 - 0$$

$$M(1.8) = +2.16 \text{ kN} \cdot \text{m}$$

Application to Computer Programming. Singularity functions are particularly well suited to the use of computers. First we note that the step function $\langle x - a \rangle^0$, which will be represented by the symbol STP, can be defined by an IF/THEN/ELSE statement as being equal to 1 for $X \geq A$ and to 0 otherwise. Any other singularity function $\langle x - a \rangle^n$, with $n \geq 1$, can then be expressed as the product of the ordinary algebraic function $(x - a)^n$ and the step function $\langle x - a \rangle^0$.

When k different singularity functions are involved, such as $\langle x - a_i \rangle^n$, where $i = 1, 2, \dots, k$, then the corresponding step functions STP(I), where $I = 1, 2, \dots, K$, can be defined by a loop containing a single IF/THEN/ELSE statement.

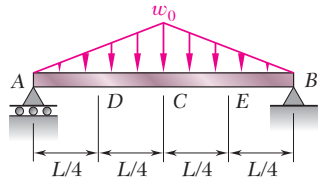

SAMPLE PROBLEM 5.9

For the beam and loading shown, determine (a) the equations defining the shear and bending moment at any point, (b) the shear and bending moment at points C, D, and E.

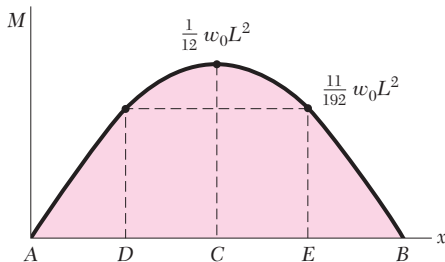
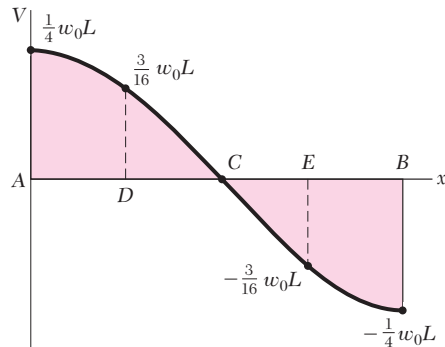
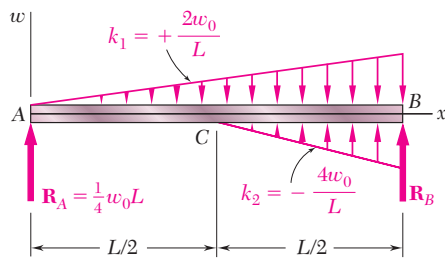
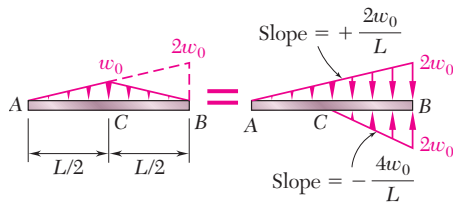

SOLUTION

Reactions. The total load is $\frac{1}{2}w_0L$; because of symmetry, each reaction is equal to half that value, namely, $\frac{1}{4}w_0L$.

Distributed Load. The given distributed loading is replaced by two equivalent open-ended loadings as shown. Using a singularity function to express the second loading, we write

$$w(x) = k_1x + k_2\langle x - \frac{1}{2}L \rangle = \frac{2w_0}{L}x - \frac{4w_0}{L}\langle x - \frac{1}{2}L \rangle \quad (1)$$

a. Equations for Shear and Bending Moment. We obtain $V(x)$ by integrating (1), changing the signs, and adding a constant equal to R_A :

$$V(x) = -\frac{w_0}{L}x^2 + \frac{2w_0}{L}\langle x - \frac{1}{2}L \rangle^2 + \frac{1}{4}w_0L \quad (2) \blacktriangleleft$$

We obtain $M(x)$ by integrating (2); since there is no concentrated couple, no constant of integration is needed:

$$M(x) = -\frac{w_0}{3L}x^3 + \frac{2w_0}{3L}\langle x - \frac{1}{2}L \rangle^3 + \frac{1}{4}w_0Lx \quad (3) \blacktriangleleft$$

b. Shear and Bending Moment at C, D, and E

At Point C: Making $x = \frac{1}{2}L$ in Eqs. (2) and (3) and recalling that whenever a quantity between brackets is positive or zero, the brackets may be replaced by parentheses, we have

$$V_C = -\frac{w_0}{L}\left(\frac{1}{2}L\right)^2 + \frac{2w_0}{L}\langle 0 \rangle^2 + \frac{1}{4}w_0L \quad V_C = 0 \blacktriangleleft$$

$$M_C = -\frac{w_0}{3L}\left(\frac{1}{2}L\right)^3 + \frac{2w_0}{3L}\langle 0 \rangle^3 + \frac{1}{4}w_0L\left(\frac{1}{2}L\right) \quad M_C = \frac{1}{12}w_0L^2 \blacktriangleleft$$

At Point D: Making $x = \frac{1}{4}L$ in Eqs. (2) and (3) and recalling that a bracket containing a negative quantity is equal to zero, we write

$$V_D = -\frac{w_0}{L}\left(\frac{1}{4}L\right)^2 + \frac{2w_0}{L}\langle -\frac{1}{4}L \rangle^2 + \frac{1}{4}w_0L \quad V_D = \frac{3}{16}w_0L \blacktriangleleft$$

$$M_D = -\frac{w_0}{3L}\left(\frac{1}{4}L\right)^3 + \frac{2w_0}{3L}\langle -\frac{1}{4}L \rangle^3 + \frac{1}{4}w_0L\left(\frac{1}{4}L\right) \quad M_D = \frac{11}{192}w_0L^2 \blacktriangleleft$$

At Point E: Making $x = \frac{3}{4}L$ in Eqs. (2) and (3), we have

$$V_E = -\frac{w_0}{L}\left(\frac{3}{4}L\right)^2 + \frac{2w_0}{L}\langle \frac{1}{4}L \rangle^2 + \frac{1}{4}w_0L \quad V_E = -\frac{3}{16}w_0L \blacktriangleleft$$

$$M_E = -\frac{w_0}{3L}\left(\frac{3}{4}L\right)^3 + \frac{2w_0}{3L}\langle \frac{1}{4}L \rangle^3 + \frac{1}{4}w_0L\left(\frac{3}{4}L\right) \quad M_E = \frac{11}{192}w_0L^2 \blacktriangleleft$$

SAMPLE PROBLEM 5.10

The rigid bar DEF is welded at point D to the steel beam AB . For the loading shown, determine (a) the equations defining the shear and bending moment at any point of the beam, (b) the location and magnitude of the largest bending moment.

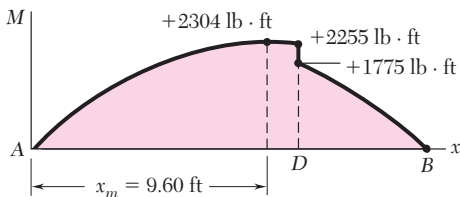
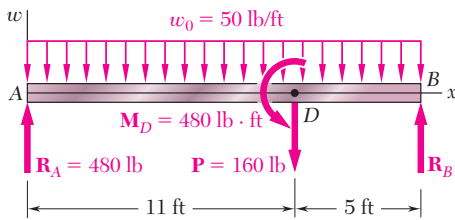
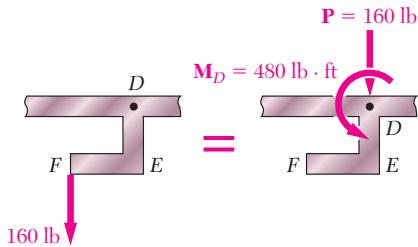
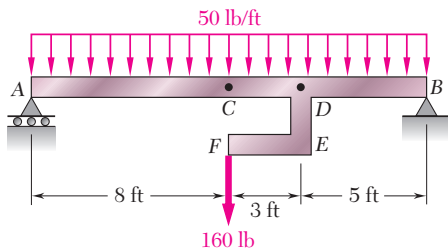

SOLUTION

Reactions. We consider the beam and bar as a free body and observe that the total load is 960 lb. Because of symmetry, each reaction is equal to 480 lb.

Modified Loading Diagram. We replace the 160-lb load applied at F by an equivalent force-couple system at D . We thus obtain a loading diagram consisting of a concentrated couple, three concentrated loads (including the two reactions), and a uniformly distributed load

$$w(x) = 50 \text{ lb/ft} \quad (1)$$

a. Equations for Shear and Bending Moment. We obtain $V(x)$ by integrating (1), changing the sign, and adding constants representing the respective contributions of R_A and P to the shear. Since P affects $V(x)$ only for values of x larger than 11 ft, we use a step function to express its contribution.

$$V(x) = -50x + 480 - 160\langle x - 11 \rangle^0 \quad (2) \quad \blacktriangleleft$$

We obtain $M(x)$ by integrating (2) and using a step function to represent the contribution of the concentrated couple M_D :

$$M(x) = -25x^2 + 480x - 160\langle x - 11 \rangle^1 - 480\langle x - 11 \rangle^0 \quad (3) \quad \blacktriangleleft$$

b. Largest Bending Moment. Since M is maximum or minimum when $V = 0$, we set $V = 0$ in (2) and solve that equation for x to find the location of the largest bending moment. Considering first values of x less than 11 ft and noting that for such values the bracket is equal to zero, we write

$$-50x + 480 = 0 \quad x = 9.60 \text{ ft}$$

Considering now values of x larger than 11 ft, for which the bracket is equal to 1, we have

$$-50x + 480 - 160 = 0 \quad x = 6.40 \text{ ft}$$

Since this value is *not* larger than 11 ft, it must be rejected. Thus, the value of x corresponding to the largest bending moment is

$$x_m = 9.60 \text{ ft} \quad \blacktriangleleft$$

Substituting this value for x into Eq. (3), we obtain

$$M_{\max} = -25(9.60)^2 + 480(9.60) - 160\langle -1.40 \rangle^1 - 480\langle -1.40 \rangle^0$$

and, recalling that brackets containing a negative quantity are equal to zero,

$$M_{\max} = -25(9.60)^2 + 480(9.60) \quad M_{\max} = 2304 \text{ lb} \cdot \text{ft} \quad \blacktriangleleft$$

The bending-moment diagram has been plotted. Note the discontinuity at point D due to the concentrated couple applied at that point. The values of M just to the left and just to the right of D were obtained by making $x = 11$ in Eq. (3) and replacing the step function $\langle x - 11 \rangle^0$ by 0 and 1, respectively.

PROBLEMS

5.98 through 5.100 (a) Using singularity functions, write the equations defining the shear and bending moment for the beam and loading shown. (b) Use the equation obtained for M to determine the bending moment at point C and check your answer by drawing the free-body diagram of the entire beam.

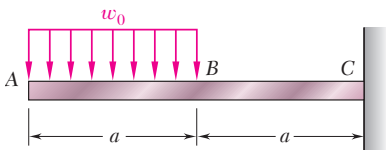

Fig. P5.98

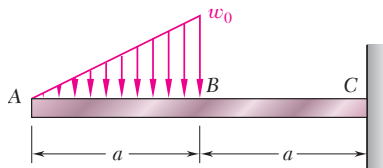

Fig. P5.99

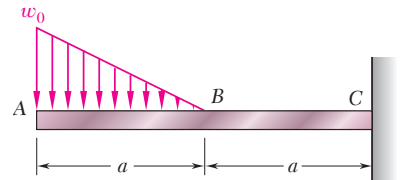

Fig. P5.100

5.101 through 5.103 (a) Using singularity functions, write the equations defining the shear and bending moment for the beam and loading shown. (b) Use the equation obtained for M to determine the bending moment at point E and check your answer by drawing the free-body diagram of the portion of the beam to the right of E .

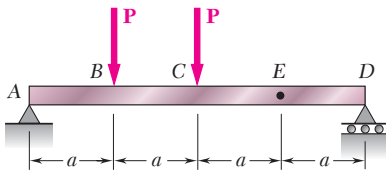

Fig. P5.101

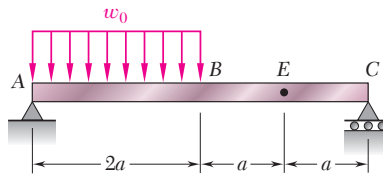

Fig. P5.102

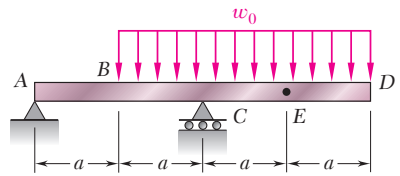

Fig. P5.103

5.104 (a) Using singularity functions, write the equations for the shear and bending moment for beam ABC under the loading shown. (b) Use the equation obtained for M to determine the bending moment just to the right of point D .

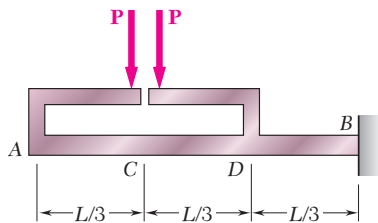

Fig. P5.104

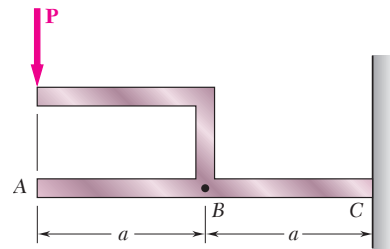

Fig. P5.105

5.105 (a) Using singularity functions, write the equations for the shear and bending moment for beam ABC under the loading shown. (b) Use the equation obtained for M to determine the bending moment just to the right of point B .

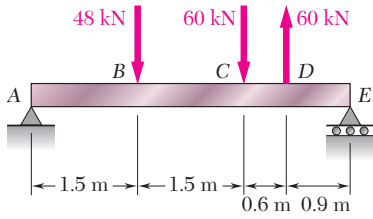

Fig. P5.106

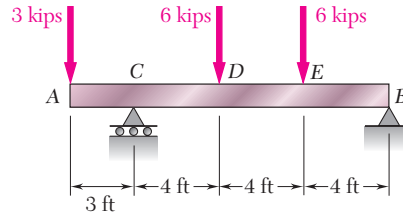

Fig. P5.107

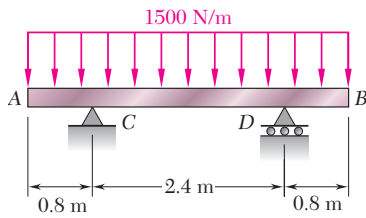

Fig. P5.108

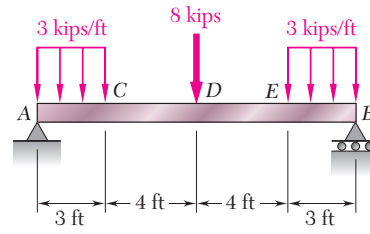

Fig. P5.109

5.106 through 5.109 (a) Using singularity functions, write the equations for the shear and bending moment for the beam and loading shown. (b) Determine the maximum value of the bending moment in the beam.

5.110 and 5.111 (a) Using singularity functions, write the equations for the shear and bending moment for the beam and loading shown. (b) Determine the maximum normal stress due to bending.

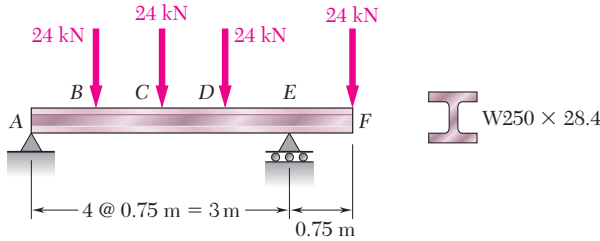

Fig. P5.110

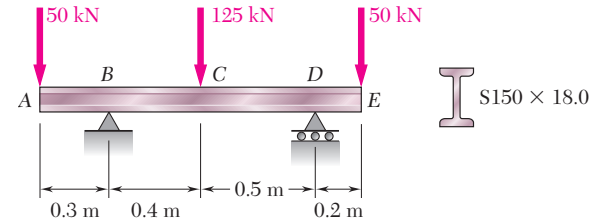

Fig. P5.111

5.112 and 5.113 (a) Using singularity functions, find the magnitude and location of the maximum bending moment for the beam and loading shown. (b) Determine the maximum normal stress due to bending.

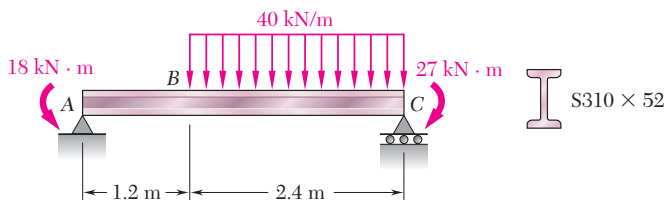

Fig. P5.112

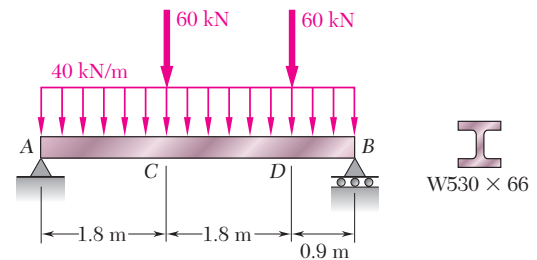

Fig. P5.113

5.114 and 5.115 A beam is being designed to be supported and loaded as shown. (a) Using singularity functions, find the magnitude and location of the maximum bending moment in the beam. (b) Knowing that the allowable normal stress for the steel to be used is 24 ksi, find the most economical wide-flange shape that can be used.

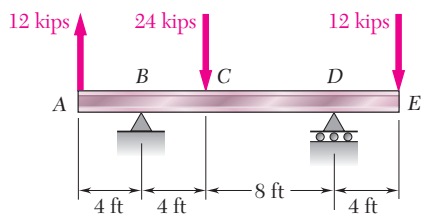

Fig. P5.114

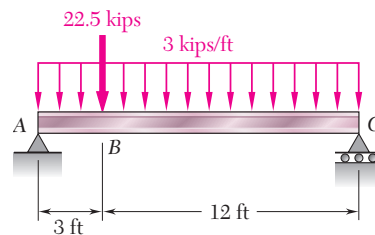

Fig. P5.115

5.116 and 5.117 A timber beam is being designed to be supported and loaded as shown. (a) Using singularity functions, find the magnitude and location of the maximum bending moment in the beam. (b) Knowing that the available stock consists of beams with an allowable stress of 12 MPa and a rectangular cross section of 30-mm width and depth h varying from 80 mm to 160 mm in 10-mm increments, determine the most economical cross section that can be used.

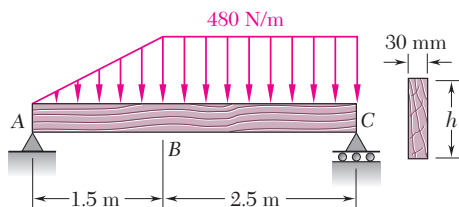

Fig. P5.116

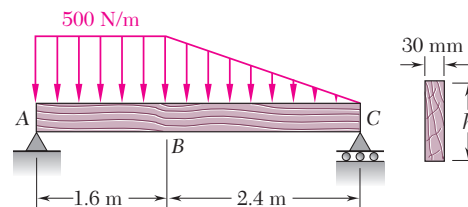

Fig. P5.117

5.118 through 5.121 Using a computer and step functions, calculate the shear and bending moment for the beam and loading shown. Use the specified increment ΔL , starting at point A and ending at the right-hand support.

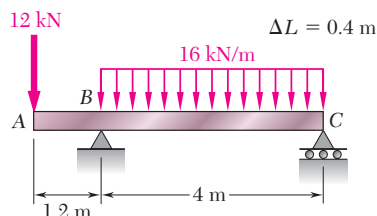

Fig. P5.118

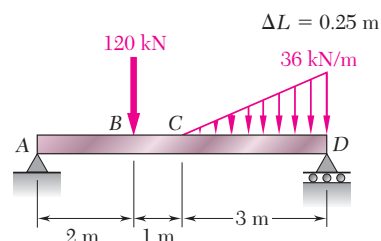

Fig. P5.119

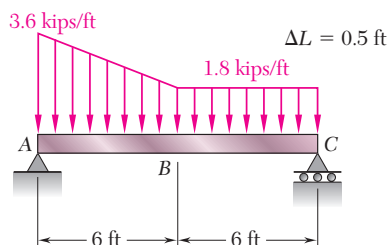

Fig. P5.120

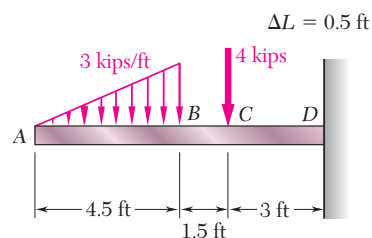

Fig. P5.121

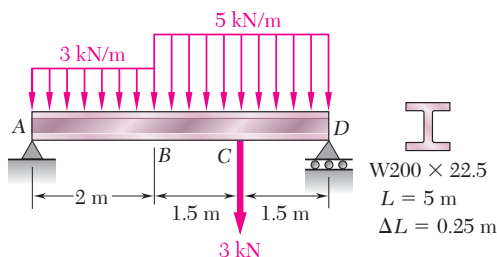

Fig. P5.122

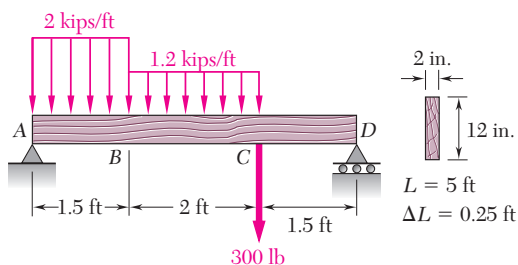

Fig. P5.124

5.122 and 5.123 For the beam and loading shown, and using a computer and step functions, (a) tabulate the shear, bending moment, and maximum normal stress in sections of the beam from $x = 0$ to $x = L$, using the increments ΔL indicated, (b) using smaller increments if necessary, determine with a 2% accuracy the maximum normal stress in the beam. Place the origin of the x axis at end A of the beam.

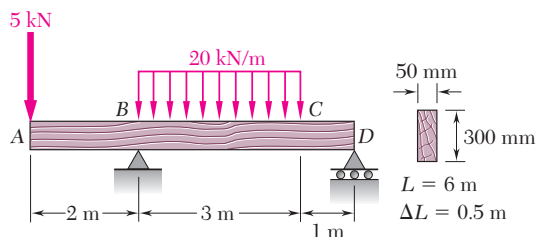

Fig. P5.123

5.124 and 5.125 For the beam and loading shown, and using a computer and step functions, (a) tabulate the shear, bending moment, and maximum normal stress in sections of the beam from $x = 0$ to $x = L$, using the increments ΔL indicated, (b) using smaller increments if necessary, determine with a 2% accuracy the maximum normal stress in the beam. Place the origin of the x axis at end A of the beam.

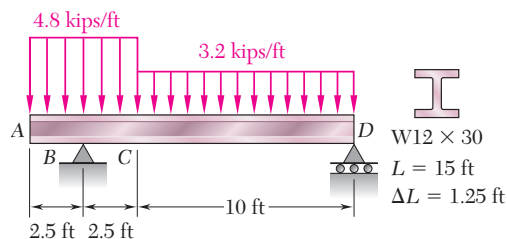

Fig. P5.125

*5.6. NONPRISMATIC BEAMS

Our analysis has been limited so far to prismatic beams, i.e., to beams of uniform cross section. As we saw in Sec. 5.4, prismatic beams are designed so that the normal stresses in their critical sections are at most equal to the allowable value of the normal stress for the material being used. It follows that, in all other sections, the normal stresses will be smaller, possibly much smaller, than their allowable value. A prismatic beam, therefore, is almost always overdesigned, and considerable savings of material can be realized by using nonprismatic beams, i.e., beams of variable cross section. The cantilever beams shown in the bridge during construction in Fig. 5.22 are examples of nonprismatic beams.

Since the maximum normal stresses σ_m usually control the design of a beam, the design of a nonprismatic beam will be optimum if the section modulus $S = I/c$ of every cross section satisfies Eq. (5.3) of Sec. 5.1. Solving that equation for S , we write

$$S = \frac{|M|}{\sigma_{\text{all}}} \quad (5.18)$$

A beam designed in this manner is referred to as a *beam of constant strength*.



Fig. 5.22

For a forged or cast structural or machine component, it is possible to vary the cross section of the component along its length and to eliminate most of the unnecessary material (see Example 5.07). For a timber beam or a rolled-steel beam, however, it is not possible to vary the cross section of the beam. But considerable savings of material can be achieved by gluing wooden planks of appropriate lengths to a timber beam (see Sample Prob. 5.11) and using cover plates in portions of a rolled-steel beam where the bending moment is large (see Sample Prob. 5.12).

EXAMPLE 5.07

A cast-aluminum plate of uniform thickness b is to support a uniformly distributed load w as shown in Fig. 5.23. (a) Determine the shape of the plate that will yield the most economical design. (b) Knowing that the allowable normal stress for the aluminum used is 72 MPa and that $b = 40$ mm, $L = 800$ mm, and $w = 135$ kN/m, determine the maximum depth h_0 of the plate.

Bending Moment. Measuring the distance x from A and observing that $V_A = M_A = 0$, we use Eqs. (5.6) and (5.8) of Sec. 5.3 and write

$$V(x) = -\int_0^x w dx = -wx$$

$$M(x) = \int_0^x V(x) dx = -\int_0^x wx dx = -\frac{1}{2} wx^2$$

(a) Shape of Plate. We recall from Sec. 5.4 that the modulus S of a rectangular cross section of width b and depth h is $S = \frac{1}{6} bh^2$. Carrying this value into Eq. (5.18) and solving for h^2 , we have

$$h^2 = \frac{6|M|}{b\sigma_{\text{all}}} \quad (5.19)$$

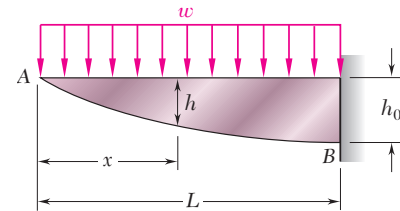

Fig. 5.23

and, after substituting $|M| = \frac{1}{2} wx^2$,

$$h^2 = \frac{3wx^2}{b\sigma_{\text{all}}} \quad \text{or} \quad h = \left(\frac{3w}{b\sigma_{\text{all}}} \right)^{1/2} x \quad (5.20)$$

Since the relation between h and x is linear, the lower edge of the plate is a straight line. Thus, the plate providing the most economical design is of *triangular shape*.

(b) Maximum Depth h_0 . Making $x = L$ in Eq. (5.20) and substituting the given data, we obtain

$$h_0 = \left[\frac{3(135 \text{ kN/m})}{(0.040 \text{ m})(72 \text{ MPa})} \right]^{1/2} (800 \text{ mm}) = 300 \text{ mm}$$

SAMPLE PROBLEM 5.11

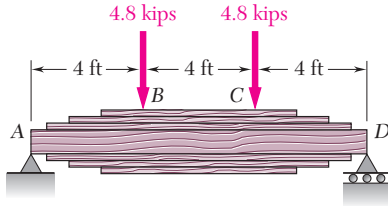

A 12-ft-long beam made of a timber with an allowable normal stress of 2.40 ksi and an allowable shearing stress of 0.40 ksi is to carry two 4.8-kip loads located at its third points. As shown in Chap. 6, a beam of uniform rectangular cross section, 4 in. wide and 4.5 in. deep, would satisfy the allowable shearing stress requirement. Since such a beam would not satisfy the allowable normal stress requirement, it will be reinforced by gluing planks of the same timber, 4 in. wide and 1.25 in. thick, to the top and bottom of the beam in a symmetric manner. Determine (a) the required number of pairs of planks, (b) the length of the planks in each pair that will yield the most economical design.

SOLUTION

Bending Moment. We draw the free-body diagram of the beam and find the following expressions for the bending moment:

From A to B ($0 \leq x \leq 48$ in.): $M = (4.80 \text{ kips})x$

From B to C ($48 \text{ in.} \leq x \leq 96$ in.):

$$M = (4.80 \text{ kips})x - (4.80 \text{ kips})(x - 48 \text{ in.}) = 230.4 \text{ kip} \cdot \text{in.}$$

a. Number of Pairs of Planks. We first determine the required total depth of the reinforced beam between B and C. We recall from Sec. 5.4 that $S = \frac{1}{6}bh^2$ for a beam with a rectangular cross section of width b and depth h . Substituting this value into Eq. (5.17) and solving for h^2 , we have

$$h^2 = \frac{6|M|}{b\sigma_{\text{all}}} \quad (1)$$

Substituting the value obtained for M from B to C and the given values of b and σ_{all} , we write

$$h^2 = \frac{6(230.4 \text{ kip} \cdot \text{in.})}{(4 \text{ in.})(2.40 \text{ ksi})} = 144 \text{ in.}^2 \quad h = 12.00 \text{ in.}$$

Since the original beam has a depth of 4.50 in., the planks must provide an additional depth of 7.50 in. Recalling that each pair of planks is 2.50 in. thick:

$$\text{Required number of pairs of planks} = 3 \quad \blacktriangleleft$$

b. Length of Planks. The bending moment was found to be $M = (4.80 \text{ kips})x$ in the portion AB of the beam. Substituting this expression and the given values of b and σ_{all} , into Eq. (1) and solving for x , we have

$$x = \frac{(4 \text{ in.})(2.40 \text{ ksi})}{6(4.80 \text{ kips})}h^2 \quad x = \frac{h^2}{3 \text{ in.}} \quad (2)$$

Equation (2) defines the maximum distance x from end A at which a given depth h of the cross section is acceptable. Making $h = 4.50$ in., we find the distance x_1 from A at which the original prismatic beam is safe: $x_1 = 6.75$ in. From that point on, the original beam should be reinforced by the first pair of planks. Making $h = 4.50 \text{ in.} + 2.50 \text{ in.} = 7.00$ in. yields the distance $x_2 = 16.33$ in. from which the second pair of planks should be used, and making $h = 9.50$ in. yields the distance $x_3 = 30.08$ in. from which the third pair of planks should be used. The length l_i of the planks of the pair i , where $i = 1, 2, 3$, is obtained by subtracting $2x_i$ from the 144-in. length of the beam. We find

$$l_1 = 130.5 \text{ in.}, \quad l_2 = 111.3 \text{ in.}, \quad l_3 = 83.8 \text{ in.} \quad \blacktriangleleft$$

The corners of the various planks lie on the parabola defined by Eq. (2).

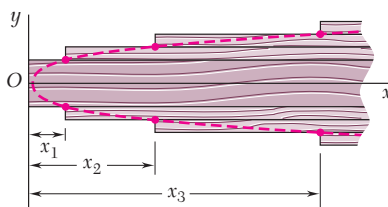
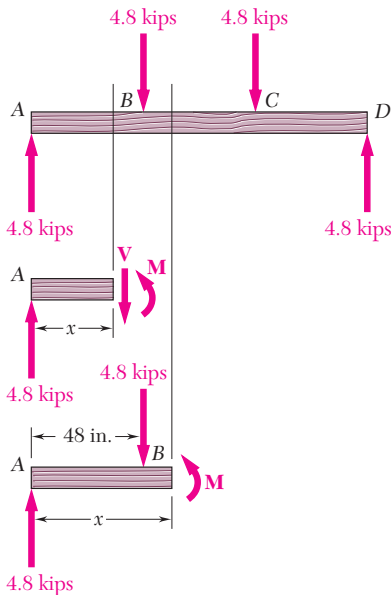

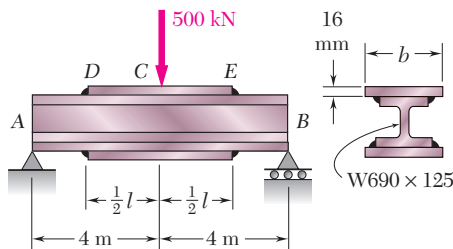

SAMPLE PROBLEM 5.12

Two steel plates, each 16 mm thick, are welded as shown to a W690 × 125 beam to reinforce it. Knowing that $\sigma_{\text{all}} = 160$ MPa for both the beam and the plates, determine the required value of (a) the length of the plates, (b) the width of the plates.

SOLUTION

Bending Moment. We first find the reactions. From the free body of a portion of beam of length $x \leq 4$ m, we obtain M between A and C:

$$M = (250 \text{ kN})x \quad (1)$$

a. Required Length of Plates. We first determine the maximum allowable length x_m of the portion AD of the unreinforced beam. From Appendix C we find that the section modulus of a W690 × 125 beam is $S = 3510 \times 10^6 \text{ mm}^3$, or $S = 3.51 \times 10^{-3} \text{ m}^3$. Substituting for S and σ_{all} into Eq. (5.17) and solving for M , we write

$$M = S\sigma_{\text{all}} = (3.51 \times 10^{-3} \text{ m}^3)(160 \times 10^3 \text{ kN/m}^2) = 561.6 \text{ kN} \cdot \text{m}$$

Substituting for M in Eq. (1), we have

$$561.6 \text{ kN} \cdot \text{m} = (250 \text{ kN})x_m \quad x_m = 2.246 \text{ m}$$

The required length l of the plates is obtained by subtracting $2x_m$ from the length of the beam:

$$l = 8 \text{ m} - 2(2.246 \text{ m}) = 3.508 \text{ m} \quad l = 3.51 \text{ m} \blacktriangleleft$$

b. Required Width of Plates. The maximum bending moment occurs in the midsection C of the beam. Making $x = 4$ m in Eq. (1), we obtain the bending moment in that section:

$$M = (250 \text{ kN})(4 \text{ m}) = 1000 \text{ kN} \cdot \text{m}$$

In order to use Eq. (5.1) of Sec. 5.1, we now determine the moment of inertia of the cross section of the reinforced beam with respect to a centroidal axis and the distance c from that axis to the outer surfaces of the plates. From Appendix C we find that the moment of inertia of a W690 × 125 beam is $I_b = 1190 \times 10^6 \text{ mm}^4$ and its depth is $d = 678 \text{ mm}$. On the other hand, denoting by t the thickness of one plate, by b its width, and by \bar{y} the distance of its centroid from the neutral axis, we express the moment of inertia I_p of the two plates with respect to the neutral axis:

$$I_p = 2\left(\frac{1}{12}bt^3 + A\bar{y}^2\right) = \left(\frac{1}{6}t^3\right)b + 2bt\left(\frac{1}{2}d + \frac{1}{2}t\right)^2$$

Substituting $t = 16 \text{ mm}$ and $d = 678 \text{ mm}$, we obtain $I_p = (3.854 \times 10^6 \text{ mm}^3)b$. The moment of inertia I of the beam and plates is

$$I = I_b + I_p = 1190 \times 10^6 \text{ mm}^4 + (3.854 \times 10^6 \text{ mm}^3)b \quad (2)$$

and the distance from the neutral axis to the surface is $c = \frac{1}{2}d + t = 355 \text{ mm}$. Solving Eq. (5.1) for I and substituting the values of M , σ_{all} , and c , we write

$$I = \frac{|M|c}{\sigma_{\text{all}}} = \frac{(1000 \text{ kN} \cdot \text{m})(355 \text{ mm})}{160 \text{ MPa}} = 2.219 \times 10^{-3} \text{ m}^4 = 2219 \times 10^6 \text{ mm}^4$$

Replacing I by this value in Eq. (2) and solving for b , we have

$$2219 \times 10^6 \text{ mm}^4 = 1190 \times 10^6 \text{ mm}^4 + (3.854 \times 10^6 \text{ mm}^3)b$$

$$b = 267 \text{ mm} \blacktriangleleft$$

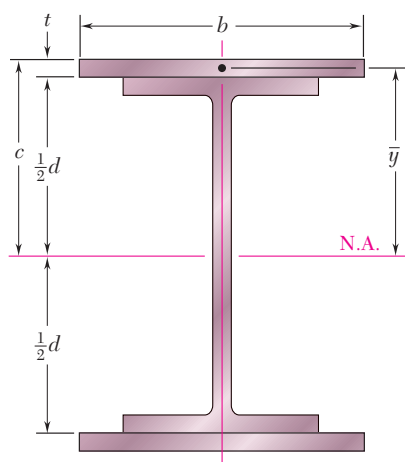
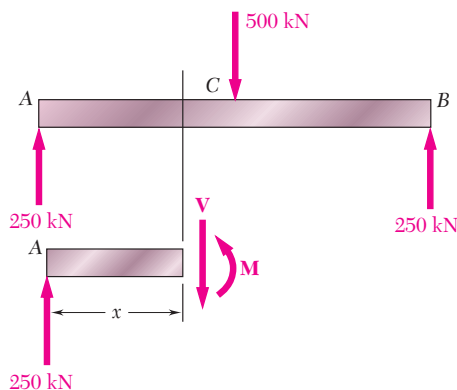

PROBLEMS

5.126 and 5.127 The beam AB , consisting of a cast-iron plate of uniform thickness b and length L , is to support the load shown. (a) Knowing that the beam is to be of constant strength, express h in terms of x , L , and h_0 . (b) Determine the maximum allowable load if $L = 36$ in., $h_0 = 12$ in., $b = 1.25$ in., and $\sigma_{\text{all}} = 24$ ksi.

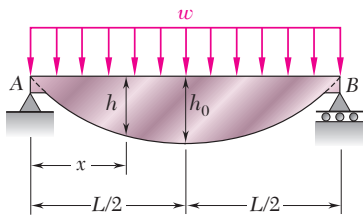

Fig. P5.126

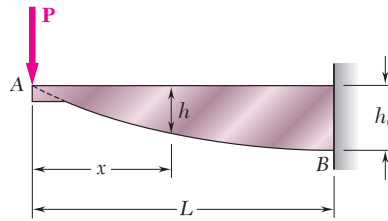

Fig. P5.127

5.128 and 5.129 The beam AB , consisting of an aluminum plate of uniform thickness b and length L , is to support the load shown. (a) Knowing that the beam is to be of constant strength, express h in terms of x , L , and h_0 for portion AC of the beam. (b) Determine the maximum allowable load if $L = 800$ mm, $h_0 = 200$ mm, $b = 25$ mm, and $\sigma_{\text{all}} = 72$ MPa.

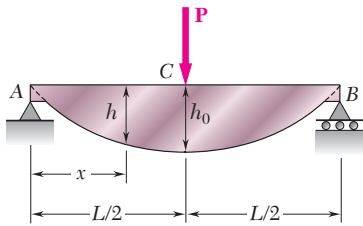

Fig. P5.128

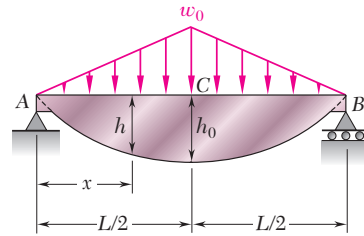

Fig. P5.129

5.130 and 5.131 The beam AB , consisting of a cast-iron plate of uniform thickness b and length L , is to support the distributed load $w(x)$ shown. (a) Knowing that the beam is to be of constant strength, express h in terms of x , L , and h_0 . (b) Determine the smallest value of h_0 if $L = 750$ mm, $b = 30$ mm, $w_0 = 300$ kN/m, and $\sigma_{\text{all}} = 200$ MPa.

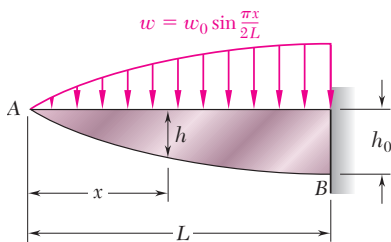

Fig. P5.130

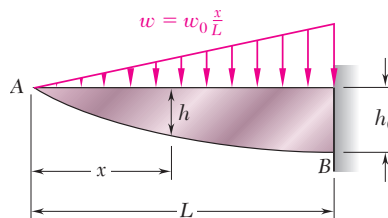

Fig. P5.131

5.132 and 5.133 A preliminary design on the use of a cantilever prismatic timber beam indicated that a beam with a rectangular cross section 2 in. wide and 10 in. deep would be required to safely support the load shown in part *a* of the figure. It was then decided to replace that beam with a built-up beam obtained by gluing together, as shown in part *b* of the figure, five pieces of the same timber as the original beam and of 2×2 -in. cross section. Determine the respective lengths l_1 and l_2 of the two inner and outer pieces of timber that will yield the same factor of safety as the original design.

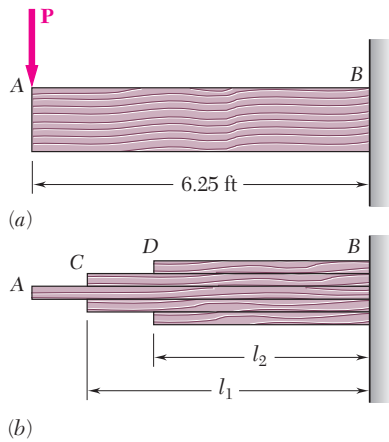

Fig. P5.132

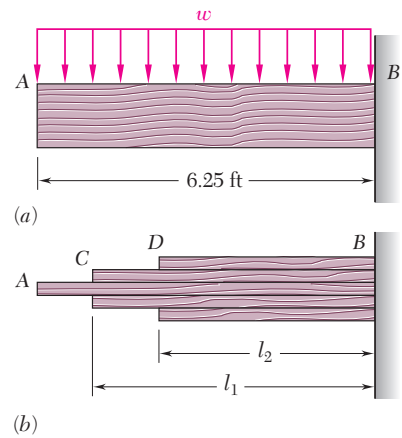

Fig. P5.133

5.134 and 5.135 A preliminary design on the use of a simply supported prismatic timber beam indicated that a beam with a rectangular cross section 50 mm wide and 200 mm deep would be required to safely support the load shown in part *a* of the figure. It was then decided to replace that beam with a built-up beam obtained by gluing together, as shown in part *b* of the figure, four pieces of the same timber as the original beam and of 50×50 -mm cross section. Determine the length l of the two outer pieces of timber that will yield the same factor of safety as the original design.

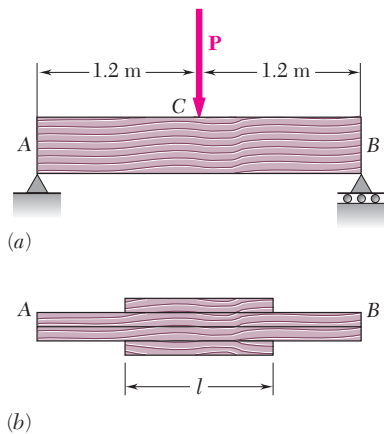

Fig. P5.134

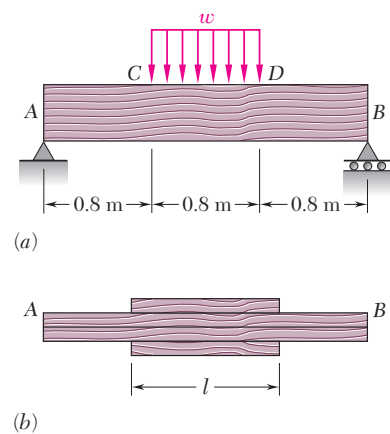

Fig. P5.135

5.136 and 5.137 A machine element of cast aluminum and in the shape of a solid of revolution of variable diameter d is being designed to support the load shown. Knowing that the machine element is to be of constant strength, express d in terms of x , L , and d_0 .

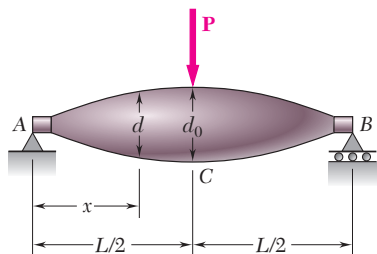

Fig. P5.136

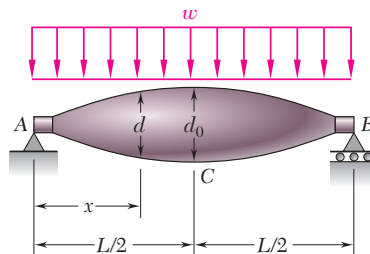

Fig. P5.137

5.138 A cantilever beam AB consisting of a steel plate of uniform depth h and variable width b is to support the concentrated load \mathbf{P} at point A . (a) Knowing that the beam is to be of constant strength, express b in terms of x , L , and b_0 . (b) Determine the smallest allowable value of h if $L = 300$ mm, $b_0 = 375$ mm, $P = 14.4$ kN, and $\sigma_{\text{all}} = 160$ MPa.

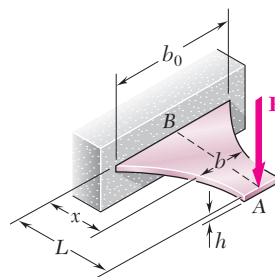

Fig. P5.138

5.139 A transverse force \mathbf{P} is applied as shown at end A of the conical taper AB . Denoting by d_0 the diameter of the taper at A , show that the maximum normal stress occurs at point H , which is contained in a transverse section of diameter $d = 1.5 d_0$.

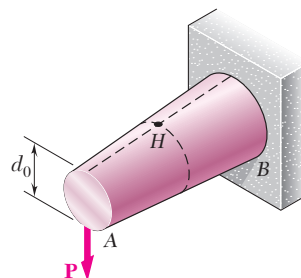

Fig. P5.139

5.140 Assuming that the length and width of the cover plates used with the beam of Sample Prob. 5.12 are, respectively, $l = 4$ m and $b = 285$ mm, and recalling that the thickness of each plate is 16 mm, determine the maximum normal stress on a transverse section (a) through the center of the beam, (b) just to the left of D .

5.141 Two cover plates, each $\frac{1}{2}$ in. thick, are welded to a $W27 \times 84$ beam as shown. Knowing that $l = 10$ ft and $b = 10.5$ in., determine the maximum normal stress on a transverse section (a) through the center of the beam, (b) just to the left of D .

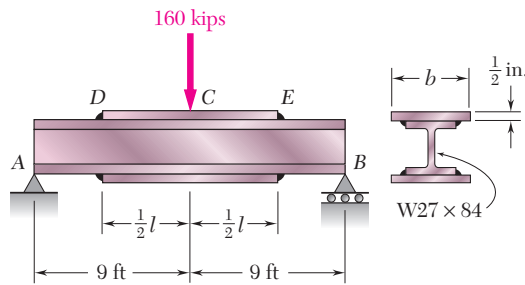

Fig. P5.141 and P5.142

5.142 Two cover plates, each $\frac{1}{2}$ in. thick, are welded to a $W27 \times 84$ beam as shown. Knowing that $\sigma_{\text{all}} = 24$ ksi for both the beam and the plates, determine the required value of (a) the length of the plates, (b) the width of the plates.

5.143 Knowing that $\sigma_{\text{all}} = 150$ MPa, determine the largest concentrated load P that can be applied at end E of the beam shown.

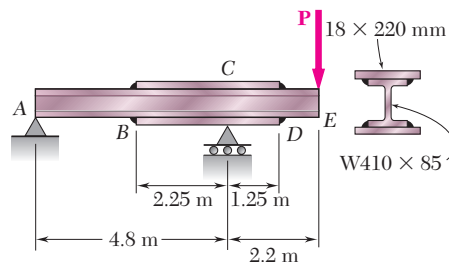

Fig. P5.143

5.144 Two cover plates, each 7.5 mm thick, are welded to a $W460 \times 74$ beam as shown. Knowing that $l = 5$ m and $b = 200$ mm, determine the maximum normal stress on a transverse section (a) through the center of the beam, (b) just to the left of D .

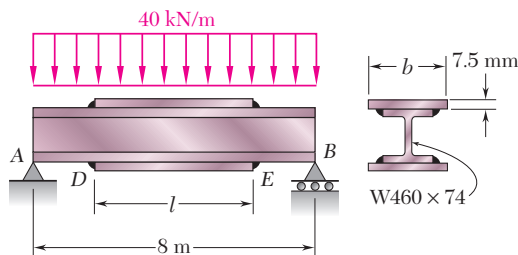

Fig. P5.144 and P5.145

5.145 Two cover plates, each 7.5 mm thick, are welded to a $W460 \times 74$ beam as shown. Knowing that $\sigma_{\text{all}} = 150$ MPa for both the beam and the plates, determine the required value of (a) the length of the plates, (b) the width of the plates.

5.146 Two cover plates, each $\frac{5}{8}$ in. thick, are welded to a W30 \times 99 beam as shown. Knowing that $l = 9$ ft and $b = 12$ in., determine the maximum normal stress on a transverse section (*a*) through the center of the beam, (*b*) just to the left of *D*.

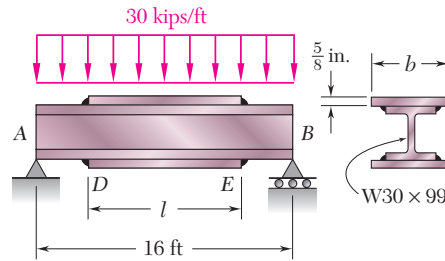

Fig. P5.146 and P5.147

5.147 Two cover plates, each $\frac{5}{8}$ in. thick, are welded to a W30 \times 99 beam as shown. Knowing that $\sigma_{\text{all}} = 22$ ksi for both the beam and the plates, determine the required value of (*a*) the length of the plates, (*b*) the width of the plates.

5.148 For the tapered beam shown, determine (*a*) the transverse section in which the maximum normal stress occurs, (*b*) the largest distributed load w that can be applied, knowing that $\sigma_{\text{all}} = 24$ ksi.

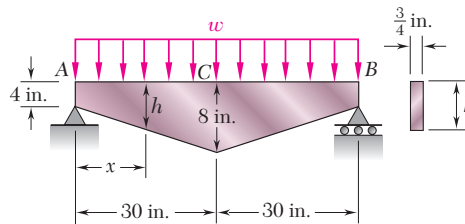

Fig. P5.148

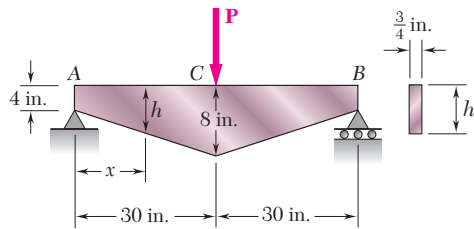

Fig. P5.149

5.149 For the tapered beam shown, determine (*a*) the transverse section in which the maximum normal stress occurs, (*b*) the largest concentrated load P that can be applied, knowing that $\sigma_{\text{all}} = 24$ ksi.

5.150 For the tapered beam shown, determine (*a*) the transverse section in which the maximum normal stress occurs, (*b*) the largest distributed load w that can be applied, knowing that $\sigma_{\text{all}} = 140$ MPa.

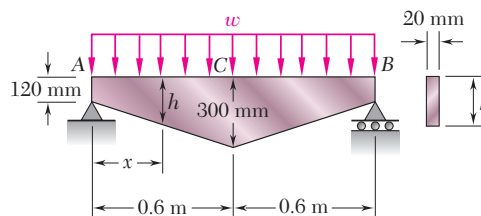

Fig. P5.150 and P5.151

5.151 For the tapered beam shown, knowing that $w = 160$ kN/m, determine (*a*) the transverse section in which the maximum normal stress occurs, (*b*) the corresponding value of the normal stress.

REVIEW AND SUMMARY FOR CHAPTER 5

This chapter was devoted to the analysis and design of beams under transverse loadings. Such loadings can consist of concentrated loads or distributed loads and the beams themselves are classified according to the way they are supported (Fig. 5.3). Only *statically determinate* beams were considered in this chapter, the analysis of statically indeterminate beams being postponed until Chap. 9.

Considerations for the design of prismatic beams

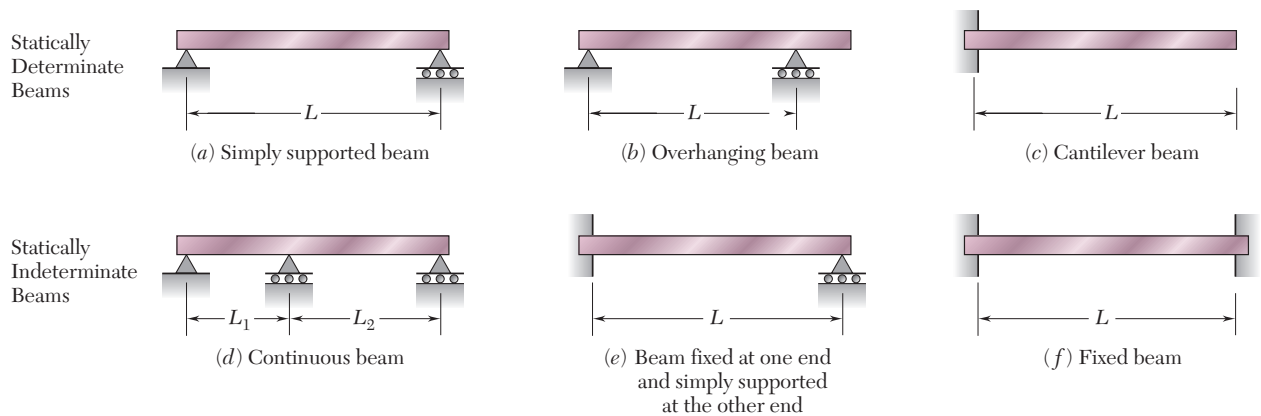

Fig. 5.3

While transverse loadings cause both bending and shear in a beam, the normal stresses caused by bending are the dominant criterion in the design of a beam for strength [Sec. 5.1]. Therefore, this chapter dealt only with the determination of the normal stresses in a beam, the effect of shearing stresses being examined in the next one.

We recalled from Sec. 4.4 the flexure formula for the determination of the maximum value σ_m of the normal stress in a given section of the beam,

$$\sigma_m = \frac{|M|c}{I} \quad (5.1)$$

where I is the moment of inertia of the cross section with respect to a centroidal axis perpendicular to the plane of the bending couple M and c is the maximum distance from the neutral surface (Fig. 4.13).

Normal stresses due to bending

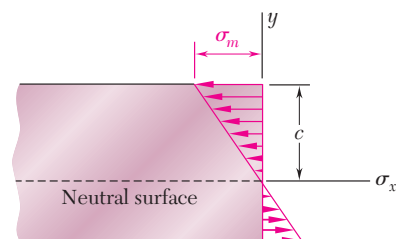
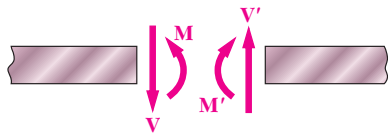

Fig. 4.13

Shear and bending-moment diagrams



(a) Internal forces
(positive shear and positive bending moment)

Fig. 5.7a

Relations among load, shear, and bending moment

We also recalled from Sec. 4.4 that, introducing the elastic section modulus $S = I/c$ of the beam, the maximum value σ_m of the normal stress in the section can be expressed as

$$\sigma_m = \frac{|M|}{S} \quad (5.3)$$

It follows from Eq. (5.1) that the maximum normal stress occurs in the section where $|M|$ is largest, at the point farthest from the neutral axis. The determination of the maximum value of $|M|$ and of the critical section of the beam in which it occurs is greatly simplified if we draw a *shear diagram* and a *bending-moment diagram*. These diagrams represent, respectively, the variation of the shear and of the bending moment along the beam and were obtained by determining the values of V and M at selected points of the beam [Sec. 5.2]. These values were found by passing a section through the point where they were to be determined and drawing the free-body diagram of either of the portions of beam obtained in this fashion. To avoid any confusion regarding the sense of the shearing force \mathbf{V} and of the bending couple \mathbf{M} (which act in opposite sense on the two portions of the beam), we followed the sign convention adopted earlier in the text and illustrated in Fig. 5.7a [Examples 5.01 and 5.02, Sample Probs. 5.1 and 5.2].

The construction of the shear and bending-moment diagrams is facilitated if the following relations are taken into account [Sec. 5.3]. Denoting by w the distributed load per unit length (assumed positive if directed downward), we wrote

$$\frac{dV}{dx} = -w \quad \frac{dM}{dx} = V \quad (5.5, 5.7)$$

or, in integrated form,

$$V_D - V_C = -(\text{area under load curve between } C \text{ and } D) \quad (5.6')$$

$$M_D - M_C = \text{area under shear curve between } C \text{ and } D \quad (5.8')$$

Equation (5.6') makes it possible to draw the shear diagram of a beam from the curve representing the distributed load on that beam and the value of V at one end of the beam. Similarly, Eq. (5.8') makes it possible to draw the bending-moment diagram from the shear diagram and the value of M at one end of the beam. However, concentrated loads introduce discontinuities in the shear diagram and concentrated couples in the bending-moment diagram, none of which is accounted for in these equations [Sample Probs. 5.3 and 5.6]. Finally, we noted from Eq. (5.7) that the points of the beam where the bending moment is maximum or minimum are also the points where the shear is zero [Sample Prob. 5.4].

A proper procedure for the design of a prismatic beam was described in Sec. 5.4 and is summarized here:

Having determined σ_{all} for the material used and assuming that the design of the beam is controlled by the maximum normal stress in the beam, compute the minimum allowable value of the section modulus:

$$S_{\text{min}} = \frac{|M|_{\text{max}}}{\sigma_{\text{all}}} \quad (5.9)$$

For a timber beam of rectangular cross section, $S = \frac{1}{6}bh^2$, where b is the width of the beam and h its depth. The dimensions of the section, therefore, must be selected so that $\frac{1}{6}bh^2 \geq S_{\text{min}}$.

For a rolled-steel beam, consult the appropriate table in Appendix C. Of the available beam sections, consider only those with a section modulus $S \geq S_{\text{min}}$ and select from this group the section with the smallest weight per unit length. This is the most economical of the sections for which $S \geq S_{\text{min}}$.

In Sec. 5.5, we discussed an alternative method for the determination of the maximum values of the shear and bending moment based on the use of the *singularity functions* $\langle x - a \rangle^n$. By definition, and for $n \geq 0$, we had

$$\langle x - a \rangle^n = \begin{cases} (x - a)^n & \text{when } x \geq a \\ 0 & \text{when } x < a \end{cases} \quad (5.14)$$

We noted that whenever the quantity between brackets is positive or zero, the brackets should be replaced by ordinary parentheses, and whenever that quantity is negative, the bracket itself is equal to zero. We also noted that singularity functions can be integrated and differentiated as ordinary binomials. Finally, we observed that the singularity function corresponding to $n = 0$ is discontinuous at $x = a$ (Fig. 5.18a). This function is called the *step function*. We wrote

$$\langle x - a \rangle^0 = \begin{cases} 1 & \text{when } x \geq a \\ 0 & \text{when } x < a \end{cases} \quad (5.15)$$

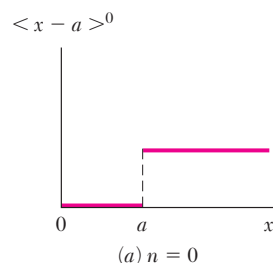

Fig. 5.18a

Design of prismatic beams

Singularity functions

Step function

Using singularity functions to express shear and bending moment

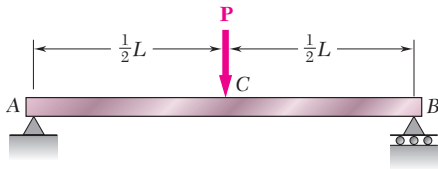

Fig. 5.8

Equivalent open-ended loadings

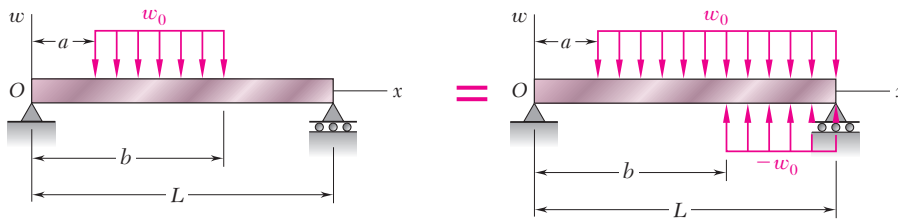

Fig. 5.20

Nonprismatic beams

Beams of constant strength

The use of singularity functions makes it possible to represent the shear or the bending moment in a beam by a single expression, valid at any point of the beam. For example, the contribution to the shear of the concentrated load P applied at the midpoint C of a simply supported beam (Fig. 5.8) can be represented by $-P\langle x - \frac{1}{2}L \rangle^0$, since this expression is equal to zero to the left of C , and to $-P$ to the right of C . Adding the contribution of the reaction $R_A = \frac{1}{2}P$ at A , we express the shear at any point of the beam as

$$V(x) = \frac{1}{2}P - P\langle x - \frac{1}{2}L \rangle^0$$

The bending moment is obtained by integrating this expression:

$$M(x) = \frac{1}{2}Px - P\langle x - \frac{1}{2}L \rangle^1$$

The singularity functions representing, respectively, the load, shear, and bending moment corresponding to various basic loadings were given in Fig. 5.19 on page 346. We noted that a distributed loading that does not extend to the right end of the beam, or which is discontinuous, should be replaced by an equivalent combination of open-ended loadings. For instance, a uniformly distributed load extending from $x = a$ to $x = b$ (Fig. 5.20) should be expressed as

$$w(x) = w_0\langle x - a \rangle^0 - w_0\langle x - b \rangle^0$$

The contribution of this load to the shear and to the bending moment can be obtained through two successive integrations. Care should be taken, however, to also include in the expression for $V(x)$ the contribution of concentrated loads and reactions, and to include in the expression for $M(x)$ the contribution of concentrated couples [Examples 5.05 and 5.06, Sample Probs. 5.9 and 5.10]. We also observed that singularity functions are particularly well suited to the use of computers.

We were concerned so far only with prismatic beams, i.e., beams of uniform cross section. Considering in Sec. 5.6 the design of nonprismatic beams, i.e., beams of variable cross section, we saw that by selecting the shape and size of the cross section so that its elastic section modulus $S = I/c$ varied along the beam in the same way as the bending moment M , we were able to design beams for which σ_m at each section was equal to σ_{all} . Such beams, called *beams of constant strength*, clearly provide a more effective use of the material than prismatic beams. Their section modulus at any section along the beam was defined by the relation

$$S = \frac{M}{\sigma_{all}} \tag{5.18}$$

REVIEW PROBLEMS

5.152 Draw the shear and bending-moment diagrams for the beam and loading shown, and determine the maximum absolute value (a) of the shear, (b) of the bending moment.

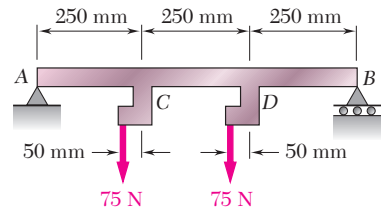

Fig. P5.152

5.153 Determine (a) the magnitude of the upward force \mathbf{P} for which the maximum absolute value of the bending moment in the beam is as small as possible, (b) the corresponding maximum normal stress due to bending. (Hint: See hint of Prob. 5.27.)

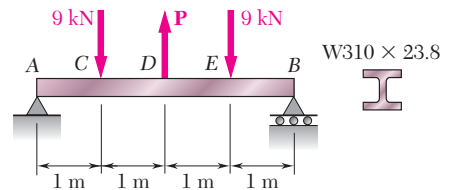

Fig. P5.153

5.154 Draw the shear and bending-moment diagrams for the beam and loading shown, and determine the maximum absolute value (a) of the shear, (b) of the bending moment.

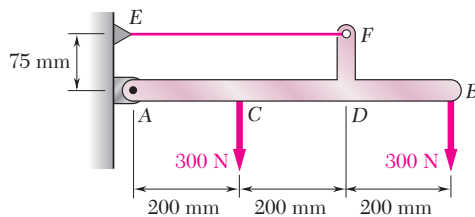

Fig. P5.154

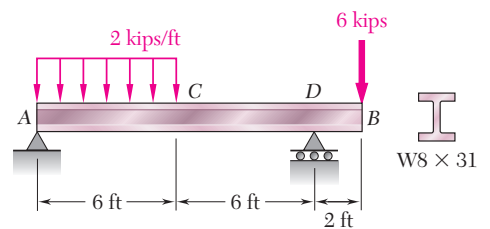

Fig. P5.155

5.155 Draw the shear and bending-moment diagrams for the beam and loading shown and determine the maximum normal stress due to bending.

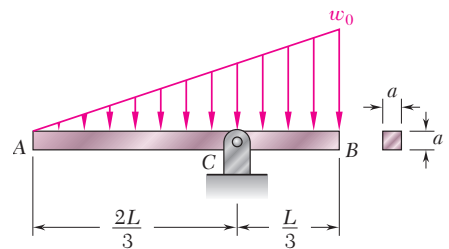

Fig. P5.156

5.156 Beam AB , of length L and square cross section of side a , is supported by a pivot at C and loaded as shown. (a) Check that the beam is in equilibrium. (b) Show that the maximum stress due to bending occurs at C and is equal to $w_0 L^2 / (1.5a)^3$.

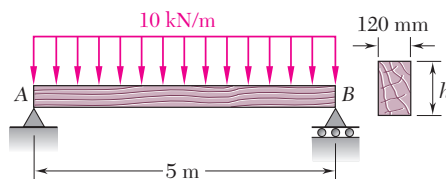

Fig. P5.157

5.157 and 5.158 For the beam and loading shown, design the cross section of the beam, knowing that the grade of timber used has an allowable normal stress of 12 MPa.

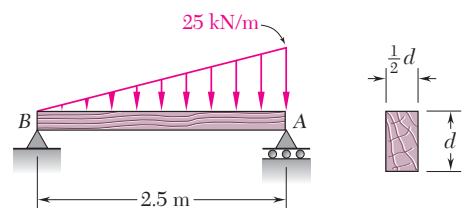

Fig. P5.158

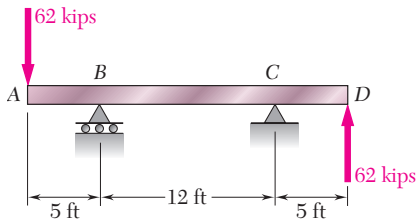

Fig. P5.159

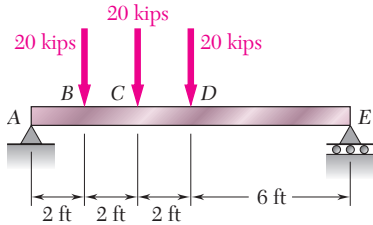

Fig. P5.161

5.159 Knowing that the allowable stress for the steel used is 24 ksi, select the most economical wide-flange beam to support the loading shown.

5.160 Determine the largest permissible value of P for the beam and loading shown, knowing that the allowable normal stress is $+80$ MPa in tension and -140 MPa in compression.

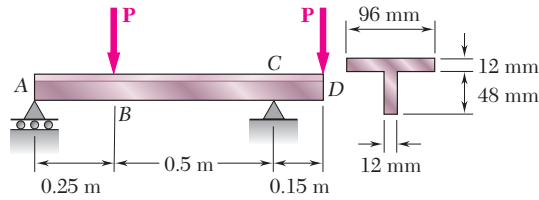

Fig. P5.160

5.161 (a) Using singularity functions, write the equations for the shear and bending moment for the beam and loading shown. (b) Determine the maximum value of the bending moment in the beam.

5.162 The beam AB , consisting of an aluminum plate of uniform thickness b and length L , is to support the load shown. (a) Knowing that the beam is to be of constant strength, express h in terms of x , L , and h_0 for portion AC of the beam. (b) Determine the maximum allowable load if $L = 32$ in., $h_0 = 8$ in., $b = 1$ in., and $\sigma_{\text{all}} = 10$ ksi.

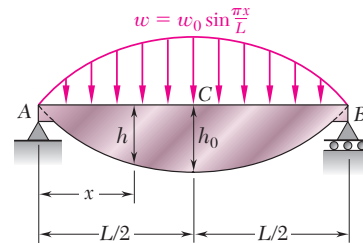

Fig. P5.162

5.163 A cantilever beam AB consisting of a steel plate of uniform depth h and variable width b is to support the distributed load w along its centerline AB . (a) Knowing that the beam is to be of constant strength, express b in terms of x , L , and b_0 . (b) Determine the maximum allowable value of w if $L = 15$ in., $b_0 = 8$ in., $h = 0.75$ in., and $\sigma_{\text{all}} = 24$ ksi.

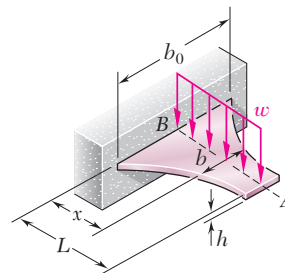

Fig. P5.163

COMPUTER PROBLEMS

The following problems are designed to be solved with a computer.

5.C1 Several concentrated loads P_i ($i = 1, 2, \dots, n$) can be applied to a beam as shown. Write a computer program that can be used to calculate the shear, bending moment, and normal stress at any point of the beam for a given loading of the beam and a given value of its section modulus. Use this program to solve Probs. 5.18, 5.21, and 5.25. (*Hint:* Maximum values will occur at a support or under a load.)

5.C2 A timber beam is to be designed to support a distributed load and up to two concentrated loads as shown. One of the dimensions of its uniform rectangular cross section has been specified and the other is to be determined so that the maximum normal stress in the beam will not exceed a given allowable value σ_{all} . Write a computer program that can be used to calculate at given intervals ΔL the shear, the bending moment, and the smallest acceptable value of the unknown dimension. Apply this program to solve the following problems, using the intervals ΔL indicated: (a) Prob. 5.65 ($\Delta L = 0.1$ m), (b) Prob. 5.69 ($\Delta L = 0.3$ m), (c) Prob. 5.70 ($\Delta L = 0.2$ m).

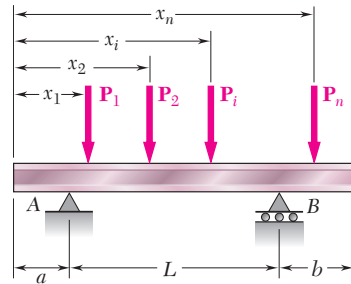

Fig. P5.C1

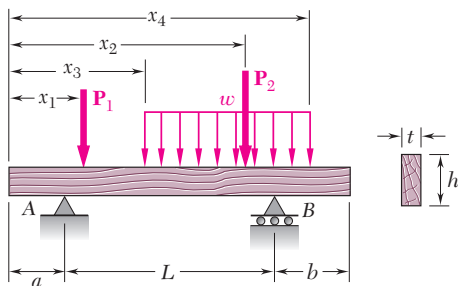

Fig. P5.C2

5.C3 Two cover plates, each of thickness t , are to be welded to a wide-flange beam of length L that is to support a uniformly distributed load w . Denoting by σ_{all} the allowable normal stress in the beam and in the plates, by d the depth of the beam, and by I_b and S_b , respectively, the moment of inertia and the section modulus of the cross section of the unreinforced beam about a horizontal centroidal axis, write a computer program that can be used to calculate the required value of (a) the length a of the plates, (b) the width b of the plates. Use this program to solve Prob. 5.145.

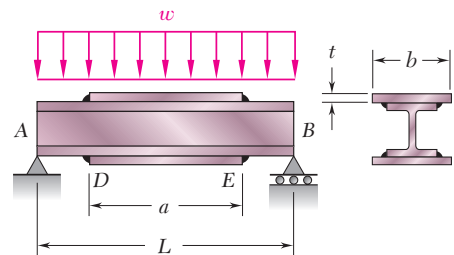

Fig. P5.C3

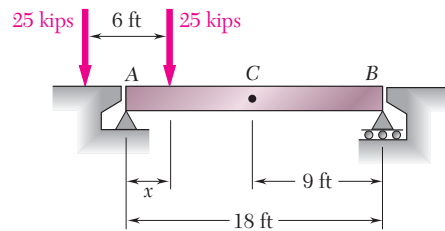

Fig. P5.C4

5.C4 Two 25-kip loads are maintained 6 ft apart as they are moved slowly across the 18-ft beam AB . Write a computer program and use it to calculate the bending moment under each load and at the midpoint C of the beam for values of x from 0 to 24 ft at intervals $\Delta x = 1.5$ ft.

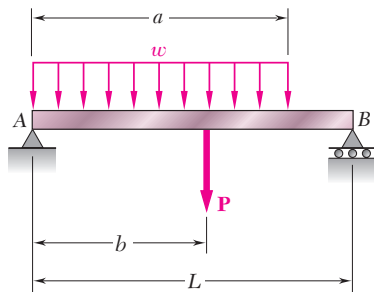

Fig. P5.C5

5.C5 Write a computer program that can be used to plot the shear and bending-moment diagrams for the beam and loading shown. Apply this program with a plotting interval $\Delta L = 0.2$ ft to the beam and loading of (a) Prob. 5.72, (b) Prob. 5.115.

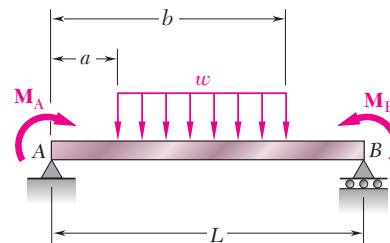

Fig. P5.C6

5.C6 Write a computer program that can be used to plot the shear and bending-moment diagrams for the beam and loading shown. Apply this program with a plotting interval $\Delta L = 0.025$ m to the beam and loading of Prob. 5.112.