

To the Student

This *Problem Solving Practice Workbook* gives you additional examples and problems for the exercises in each lesson. The exercises are designed to aid your study of mathematics by reinforcing important mathematical skills needed to succeed in the everyday world. The materials are organized by chapter and lesson, with one Practice worksheet for every lesson in Chapters 1–8 of *California Algebra Readiness*.

Always keep your completed workbook handy. Along with your textbook, daily homework, and class notes, the completed *Problem Solving Practice Workbook* can help you in reviewing for quizzes and tests.

To the Teacher

These worksheets are the same ones found in the Chapter Resource Masters for *California Algebra Readiness*. The answers to these worksheets are available at the end of each Chapter Resource Masters booklet as well as in your Teacher Wraparound Edition interleaf pages.

The McGraw-Hill Companies



Copyright © by The McGraw-Hill Companies, Inc. All rights reserved. Except as permitted under the United States Copyright Act, no part of this publication may be reproduced or distributed in any form or by any means, or stored in a database or retrieval system, without prior permission of the publisher.

Send all inquiries to:
Glencoe/McGraw-Hill
8787 Orion Place
Columbus, OH 43240-4027

ISBN: 978-0-07-880469-4
MHID: 0-07-880469-8

Problem Solving Practice Workbook, California Algebra Readiness

Printed in the United States of America.

3 4 5 6 7 8 9 10 045 16 15 14 13 12 11 10 09 08

Table of Contents

Lesson/Title	Page
1-1 A Plan for Problem Solving	1
1-2 Expressions and Equations	2
1-3 Order of Operations	3
1-4 Commutative and Associative Properties	4
1-5 Distributive Property	5
1-6 Problem-Solving Strategy: Guess and Check	6
1-7 Other Properties	7
1-8 Simplifying Expressions	8
2-1 Equations	9
2-2 Integers	10
2-3 Adding and Subtracting Integers	11
2-4 Multiplying Integers	12
2-5 Dividing Integers	13
2-6 Problem-Solving Strategy: Look for a Pattern	14
2-7 Solving Equations	15
3-1 Fractions	16
3-2 Fractions and Mixed Numbers	17
3-3 Factors and Simplifying Fractions	18
3-4 Problem-Solving Strategy: Draw a Diagram	19
3-5 Multiplying Fractions	20
3-6 Dividing Fractions	21
3-7 Adding and Subtracting Fractions with Like Denominators	22
3-8 Adding Fractions with Unlike Denominators	23
3-9 Subtracting Fractions with Unlike Denominators	24
3-10 Fractions in Expressions and Equations	25
4-1 Fractions and Decimals	26
4-2 Adding and Subtracting Decimals	27
4-3 Multiplying Decimals	28
4-4 Dividing Decimals	29
4-5 Problem-Solving Strategy: Work Backward	30
4-6 Decimals in Expressions and Equations	31
5-1 Exponents	32
5-2 Integer Exponents	33
5-3 Problem-Solving Strategy: Solve a Simpler Problem	34
5-4 Roots	35
5-5 Simplifying and Evaluating Expressions	36
5-6 Comparing and Ordering Rational Numbers	37

6-1	Ratios and Rates	38
6-2	Fractions, Decimals, and Percents	39
6-3	Proportions and Proportional Reasoning	40
6-4	The Percent Proportion	41
6-5	Problems Involving Percents	42
6-6	Direct Variation	43
6-7	Problem-Solving Strategy: Make a Table	44
7-1	The Coordinate Plane	45
7-2	Problem-Solving Strategy: Draw a Graph	46
7-3	Relationships Involving Equal Ratios	47
7-4	Measures as Rates and Products	48
7-5	Slope	49
7-6	Linear Functions	50
7-7	The Pythagorean Theorem	51
8-1	Triangles and Quadrilaterals	52
8-2	Congruency and Similarity	53
8-3	Coordinate Geometry	54
8-4	Perimeter	55
8-5	Area	56
8-6	Problem-Solving Strategy: Make a Model	57
8-7	Solid Figures and Volume	58
8-8	Surface Area	59

1-1**Practice: Problem Solving*****A Plan for Problem Solving***

Use the four-step plan to solve each problem.

GEOGRAPHY For Exercises 1 and 2, use the poster information about Crater Lake National Park in Oregon.

Visit Crater Lake National Park

90 miles of trails
26 miles of shoreline
Boat tours available
Open 24 hours

Directions from Klamath Falls: Take U.S. Highway 97 north 21 miles, then go west on S.R. 62 for 29 miles.

<p>1. How many more miles of trails are there than miles of shoreline in Crater Lake National Park?</p>	<p>2. How many miles is it from Klamath Falls to Crater Lake National Park?</p>
<p>3. SPORTS Jasmine swims 12 laps every afternoon, Monday through Friday. How many laps does she swim in one week?</p>	<p>4. SPORTS Samantha can run one mile in 8 minutes. At this rate, how long will it take for her to run 5 miles?</p>
<p>5. SPORTS On a certain day, 525 people signed up to play softball. If 15 players are assigned to each team, how many teams can be formed?</p>	<p>6. PATTERNS Complete the pattern: 5, 7, 10, 14, __, __, __</p>
<p>7. SHOPPING Josita received \$50 as a gift. She plans to buy two cassette tapes that cost \$9 each and a headphone set that costs \$25. How much money will she have left?</p>	<p>8. BUS SCHEDULE A bus stops at the corner of Elm Street and Oak Street every half hour between 9 A.M. and 3 P.M. and every 15 minutes between 3 P.M. and 6 P.M. How many times will a bus stop at the corner between 9 A.M. and 6 P.M.?</p>

1-2 Practice: Problem Solving

Expressions and Equations

1. **COMIC BOOKS** Malcolm has 62 comic books and his friend Meg has 49 comic books. What numerical expression represent the total number of comic books they have together?

2. **MUSEUM** The Simpson family visited the local museum one afternoon. Ticket prices are shown below.

Ticket	Price
Adult (19–64)	\$17.50
Student (12–18)	\$9.00
Child (3–11)	\$6.00
Senior Citizen (65+)	\$7.00

Write an expression that can be used to calculate the total price the Simpson family paid for 2 adult, 2 student, 1 child and 1 senior citizen ticket.

3. **TEMPERATURE** One city's warmest day of the year reached 107°F . The coldest day of the year fell to 17°F . Write a numerical expression to represent the difference in temperature on those two days.
4. **DIMENSIONS** Marco is drawing a rectangle with a length of 12 inches and width of 10 inches. Write an expression to represent the perimeter of the rectangle.

BASEBALL For Exercises 5 and 6, use the information in the table below.

Both the American League and the National League in Major League Baseball select a most valuable player (MVP) each year. Twenty-eight sports journalists rank order five players that they think deserve the honor. The points are awarded according to the table below. The player with the highest total receives the award.

Rank Order	Points
First place	14
Second place	9
Third place	8
Fourth place	7
Fifth place	6

5. Player A received 21 votes for first place, 5 votes for second place, 1 vote for third place, and 1 vote for fourth place. Write an expression to represent the number of points Player A earned.
6. Player B received 1 vote for first place, 14 votes for second place, 9 votes for third place, 2 votes for fourth place, and 2 votes for fifth place. Write an expression to represent the number of points Player B earned.

1-3 Practice: Problem Solving**Order of Operations**

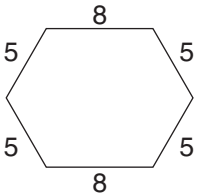
<p>1. FOOTBALL The middle school team scored three field goals worth three points each and two touchdowns worth seven points each, including extra points. Write a numerical expression to find the team's score. Then evaluate the expression.</p>	<p>2. BOOKS Juan goes to the school book fair where paperback books are \$1.50 and hardback books are \$3.00. Juan buys 5 paperback and 2 hardback books. Write a numerical expression to find how much Juan paid for the books. Then evaluate the expression.</p>
<p>3. GEOMETRY The perimeter of a hexagon is found by adding the lengths of all six sides of the hexagon. For the hexagon below write a numerical expression to find the perimeter. Then evaluate the expression.</p> 	<p>4. MONEY Aisha bought school supplies consisting of 6 spiral notebooks costing \$0.39 each, 2 packages of pencils at \$0.79 each, and a 3-ring binder for \$1.99. Write an expression to find the total amount Aisha spent on school supplies. Then evaluate the expression.</p>
<p>5. REASONING Use the order of operations and the digits 2, 4, 6, and 8 to create an expression with a value of 2.</p>	<p>6. NUMBER SENSE Without parentheses, the expression $8 + 30 \div 2 + 4$ equals 27. Place parentheses in the expression so that it equals 13; then 23.</p>
<p>7. MONEY Tyrone bought 5 postcards at \$0.55 each and a set of postcards for \$1.20. Write an expression to find the total amount Tyrone spent on postcards. Then evaluate the expression.</p>	<p>8. DINING Mr. Firewalks took his family out to eat. They ordered 3 meals costing \$8.99 each, 2 sodas at \$1.50 each, and 1 glass of tea for \$1.25. Write an expression to find the total amount the Firewalks family spent on dinner before taxes and tip. Then evaluate the expression.</p>

1-4 Practice: Problem Solving***Commutative and Associative Properties***

- 1. TRAVEL** Mike and his family are driving from Dallas to Fort Worth, a distance of 30 miles, to visit a cousin. Then, they will drive from Fort Worth to San Antonio, a distance of 229 miles, to visit his grandparents. On the way back, Mike reverses his trip and travels from San Antonio to Dallas through Fort Worth.

Write one equation to show the distance traveled from Dallas to San Antonio. Write a second equation to show the distance traveled from San Antonio to Dallas. What do you notice about the distance traveled each way?

- 2. SHOPPING** Sara is buying some new clothes for school. She buys a pair of shoes for \$65, a blouse for \$42, jeans for \$58 and a skirt for \$35. Using the Associative and Commutative Properties of Addition, add the prices so that the total cost can be found easily with mental arithmetic.

- 3. COMBINATIONS** A special lock has a unique combination. A value is assigned that opens the lock, and any combination of single-digit numbers and operations, with or without parentheses, will open the lock. For example, if 40 is the value assigned to the lock, then 8×5 will open the lock. Find 3 different ways to unlock the lock if the combination is 17.

- 4. CLOTHES** Most people wear both socks and shoes when they go to work. When getting dressed, is putting on socks and shoes a commutative process? Explain.

BASEBALL For Exercises 5 and 6, use the information in the table below.

One statistic used in baseball is percent (PCT) or the number of games a team has won of all of the games played to date. Alfie plays for the Lions in his town league. The table below shows the standing at the end of the season.

Team	Wins	Losses	PCT
Lions	15	5	0.75
Bears	14	6	0.7
Bullhorns	8	12	6

- 5.** Alfie used the Commutative Property and divided 20 by 8 to find the percent for the Bullhorns. What error did Alfie make?
- 6.** Alfie knows that the Mavericks have won 11 out of 20 games. He subtracts to find that the Mavericks lost -9 games. What error did Alfie make?

1-5 Practice: Problem Solving***Distributive Property***

<p>1. MUSIC Mr. Escalante and Mrs. Turner plan to take their music classes to a musical revue. Tickets cost \$6 each. Mr. Escalante's class needs 22 tickets and Mrs. Turner's class needs 26 tickets. Use the Distributive Property to write a sentence to express how to find the total cost of tickets in two ways.</p>	<p>2. Neil purchased 4 dozen blueberry bagels and 6 dozen cinnamon-raisin bagels for a fund-raiser at school. How many bagels did Neil purchase in all?</p>
<p>3. Jill has been training to run a marathon for 3 weeks. On the first 7 days, she ran 2.5 miles per day. On the next 7 days, she ran 3 miles each day. On each of the last 7 days, she ran 3.75 miles. How many miles in all did Jill run?</p>	<p>4. The company assistant put in an order for supplies that included 15 dozen pens and 8 dozen pencils. How many individual pens and pencils were ordered in all?</p>
<p>5. The Music Source is having a sale on CDs and cassettes. They have 140 CDs and 215 cassettes they are selling for \$5.29 each. How much money will they earn if all CDs and cassettes are sold?</p>	<p>6. If the Music Source decreased the selling price to \$4.95, how much money would they earn? What is the difference in earnings from Exercise 5?</p>
<p>7. MONEY Mei was trying to figure out the cost of 4 boxes of cereal for \$2.25 each. Write a sentence to show Mei an easy way to do her calculations. What property did you apply to help her?</p>	<p>8. Kevin earns \$3.15 per hour for each hour he helps Mr. McCready with lawn work. Kevin worked the following hours: Friday: 3.25 hours; Saturday: 4 hours; Sunday: 2.5 hours. How much money did Kevin earn in all? Round to the nearest cent.</p>

1-6 Practice: Problem Solving**Problem-Solving Strategy: Guess and Check**

Use the guess-and-check strategy to solve each problem.

SKATES For Exercises 1 and 2, use the information below. It shows the income a sporting goods store received in one week for skate sharpening.

Skate Sharpening Income for Week 6			
Cost to Sharpen Hockey Skates	Cost to Sharpen Figure Skates	Total Pairs of Skates Sharpened	Total Income from Skate Sharpening
\$6 a pair	\$4 a pair	214	\$1,096

<p>1. How many pairs of hockey skates and figure skates were sharpened during the week?</p>	<p>2. How much more did the sporting goods store earn sharpening hockey skates than figure skates?</p>
<p>3. FIELD TRIP At the science museum, the laser light show costs \$2 and the aquarium costs \$1.50. On a class field trip, each of the 30 students went to either the laser light show or the aquarium. If the teacher spent exactly \$51 on tickets for both attractions, how many students went to each attraction?</p>	<p>4. NUMBERS Mr. Wahl is thinking of two numbers. The sum of the numbers is 27. The product of the numbers is 180. What two numbers is Mr. Wahl thinking of?</p>
<p>5. READING MARATHON Mrs. Johnson's class broke the school reading record by reading a total of 9,795 pages in one month. Each student read a book that was either 245 pages or 360 pages. If 32 students participated in the reading marathon, how many students read each book?</p>	<p>6. REWARDS The soccer coaches bought gifts for all their soccer players. Gifts for the girls cost \$4 each and gifts for the boys cost \$3 each. There were 32 more boy soccer players than girl soccer players. If the coaches spent a total of \$411 on gifts for their players, how many boys and girls played soccer?</p>

1-7 Practice: Problem Solving***Other Properties***

Use what you know about properties to answer the questions.

1. Lucy noticed the price of gasoline yesterday. Yesterday, the price was \$2.87 per gallon. If the price of gasoline today is \$2.87 per gallon, write an equation to compare the price of gas yesterday to the price of gas today.
2. Maria has 27 CDs in her collection. Rachel has the same number of CDs that Maria has. Write an equation using the Identity Property of Multiplication to compare Maria's CDs to Rachel's CDs.
3. Belinda went to a "Buy One, Get One Free" sale. If one book costs \$40, write an equation to show the cost of one book to the cost of two books.
4. George earns \$1 per video rented during his workday. If he rented 85 videos, which property is used to find George's earnings?
5. On Friday the temperature at 4 P.M. was 75° . The temperature did not increase or decrease between 4 P.M. and 4:30 P.M. Write an equation to compare the temperature at 4 P.M. on Friday to the temperature at 4:30 P.M. on Friday.
6. Ophelia practiced her viola for 45 minutes on Tuesday. On Wednesday she practiced as many hours as she practiced on Tuesday. Write an equation using the Identity Property of Multiplication to show Tuesday's minutes compared to Wednesday's minutes.

1-8 Practice: Problem Solving***Simplifying Expressions***

- 1. ANIMAL SHELTER** There are 15 dogs, 22 cats, and 4 rabbits at a shelter. Each dog needs a collar, a bowl, and a toy. Each cat needs a collar and a bowl. In addition, one scratching post is needed for all of the cats. Each rabbit needs a bowl. Write an expression in simplest form to show the total number of collars c , bowls b , and toys t , that the animal shelter needs for its resident animals.

- 2. GEOMETRY** Rangley's father is making a walkway. He will use large tiles for the walkway like the one shown below. Write an expression in simplified form for the perimeter of the pentagon.

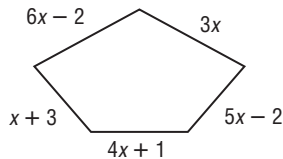

- 3. SCHOOL SUPPLIES** Mr. Raphael needs to buy notebooks for his children to start the school year. His son Manny needs some notebooks. His daughter Daphne needs twice as many as does Manny. His other daughter Ophelia says she needs one fewer than 3 times as many as Manny needs.

Mr. Raphael buys x notebooks for Manny. How many notebooks will he need to buy in all? Write an expression in simplified form to show how many notebooks Mr. Raphael needs to buy.

- 4. SHOPPING** Three families recently ordered jeans from a catalogue. The Rodriguez family ordered twice as many jeans as the Gomez family. The Jimenes family ordered 4 times as many jeans as the Gomez family. Write an expression to show how many jeans each family bought.

AMUSEMENT PARKS For Exercises 5 and 6, use the following information.

Three families went to Six Flags together. The number of people in each family is listed in the table.

Family	Adults	Children	Seniors
McGraw	2	3	1
Churchill	1	2	2
Sanchez	2	1	1

The admission tickets cost was \$40 for adults, \$25 for children, and \$27 for seniors.

- 5.** Write an expression in simplest form to show how much it costs all adults a , children c , and seniors s from the three families to attend the amusement park.
- 6.** Write an expression to find how much the three families spent in all for admission tickets.

2-1 Practice: Problem Solving

Equations

<p>1. GAS MILEAGE Mr. Moseley's car has a 20-gallon gas tank. It took 14 gallons of gas to fill his tank. Use the equation $14 + g = 20$ to find the number of gallons g that he had before he filled his tank with gas.</p>	<p>2. PAINTING Latisha earned \$5 an hour painting for her dad. If she made \$40 last week, use $5h = 40$ to find how many hours h she painted.</p>
<p>3. LUMBER Mrs. Garcia had a piece of board that was 15 feet long. She cut off 7 feet. Use the equation $7 + \ell = 15$ to determine how much of the board ℓ she has left.</p>	<p>4. MAGAZINES Mahpee was selling magazine subscriptions. He earned \$5 plus \$2 for each subscription he sold. If Mahpee earned \$25, use the equation $25 = 5 + 2n$ to find the number of subscriptions n he sold.</p>
<p>5. TIRES The cost of a car tire is \$45 plus \$10 per order regardless of the number of tires purchased. If Mrs. Sato places an order for \$190, use the equation $45t + 10 = 190$ to find the number of tires t she purchased.</p>	<p>6. AREA If the area of a rectangle is 30 square centimeters and the length is 6 centimeters, use the equation $30 = 6w$ to find the width w of the rectangle.</p>
<p>7. SUPPLIES The Jones Middle School had \$4,000 to spend on office supplies. They had already spent \$1,250. Use the equation $1,250 + d = 4,000$ to find how much money d the school had left for other supplies.</p>	<p>8. PENCILS Mi-Leng spent 90 cents on 6 pencils. Use the equation $90 = 6c$ to find the cost c of each pencil.</p>

2-2 Practice: Problem Solving

Integers

1. ELEVATION The surface of the Dead Sea is 1312 feet below sea level. Use an integer to express the surface of the Dead Sea in relation to sea level.

2. FOOTBALL During a football game between the Eagles and the Bears, the quarterback of the Eagles was tackled for a loss of six yards. Use an integer to express the Eagles' new location on the football field in relation to their previous location.

3. WINDCHILL The windchill factor, shown in the table below, indicates how much colder the wind feels than the actual outdoor temperature. How much colder does it feel when the outdoor temperature is 10°F and the wind is blowing at 10 miles per hour?

Windchill Factor								
Wind (mph)	Temperature (°F)							
	20	15	10	5	0	-5	-10	-15
5	13	7	1	-5	-11	-16	-22	-28
10	9	3	-4	-10	-16	-22	-28	-35
15	6	0	-7	-13	-19	-26	-32	-39
20	4	-2	-9	-15	-22	-29	-35	-42
25	3	-4	-11	-17	-24	-31	-37	-44
30	1	-5	-12	-19	-26	-33	-39	-46
35	0	-7	-14	-21	-27	-34	-41	-48
40	-1	-8	-15	-22	-29	-36	-43	-50

4. BANKING One page in Joe's check register looks like the following table. How do the total deposits compare with the total withdrawals?

Description	Deposit	Withdrawal	Balance
Movies		\$15	\$360
Paycheck	\$300		\$660
Gas		\$25	\$635
Groceries		\$50	\$585
Car		\$150	\$435

GOLF For Exercises 5–7, use the following information.

Joe is a golfer. He keeps track of his scores by noting the difference between his score and par, the number of swings it should take the ball to descend into the hole. The scorecard below shows Joe's scores from a recent round of golf.

Big Lake Country Club									
Hole	1	2	3	4	5	6	7	8	9
Par	4	4	5	4	4	3	3	4	5
Score	2	-1	-1	1	0	-2	1	0	2
Hole	10	11	12	13	14	15	16	17	18
Par	4	4	4	3	3	4	5	4	5
Score	1	0	0	-1	2	1	-2	1	-1

5. Compare Joe's scores on the 7th and 13th holes.

6. Compare Joe's scores on the 6th and 18th holes.

7. Write the scores for the 1st, 3rd, 4th and 8th holes in the order from least to greatest.

2-3 Practice: Problem Solving***Adding and Subtracting Integers***

1. DIVING Submarine descended 32 feet below the surface. It rose 13 feet to look at a coral reef. Write an addition sentence to find its current depth.

2. TEMPERATURE During a 24-hour period, the high temperature was 18°F . The low temperature was -4°F . What was the temperature range for the day?

3. EARTH SCIENCE Yosemite Falls is the highest waterfall in North America and the fifth highest in the world. When viewed from the valley, it appears to be a single waterfall. However, it actually has three parts.

The upper fall has the longest drop of 1430 feet. The middle cascade is 675 feet long, and the lower fall drops another 320 feet. What is the total length that the water falls?

4. GOLF Jim and Tom played against each other in a golf tournament. Jim's final score was 6 under par, the average number of swings it should take a golfer to get his ball in the hole. Tom's score was 1 under par. Describe the outcome of their match.

STOCKS For Exercises 5–7, use the table below.

The Dow Jones Industrial Average Index tracks the performance on the New York Stock Exchange of 30 of the largest companies in the United States. The table below shows the change in the Average on a given trading day.

Dow Jones Industrial Average	
Time	Change (Dollars)
10:00	+3.00
12:00	-5.00
2:00	-2.00
4:00	+6.00

5. Write an expression to show the change in value of the Average during the day.

6. The Average closed the day before at 10,812. What was the index at noon?

7. By the end of the day, did the Average gain or lose value? Explain your reasoning.

2-4 Practice: Problem Solving***Multiplying Integers***

1. BUSINESS Many companies sell shares in the company in order to raise additional money to invest in new projects. Mr. Monroe purchased 10,000 shares of a new company at \$3.12 per each share. How much money did Mr. Monroe spend to purchase the shares?

2. AVIATION An airplane approaching its destination has begun its final descent into the airport. The plane descends at a rate of 300 feet per minute. What is the change in altitude of the plane after four minutes?

3. FLOODS Heavy snows and rains caused the river near Harvey's house to flood. When the river crested, it was 5 feet above its normal level. The water started to recede at a rate of 2 inches per day. How many feet did the river recede after 14 days?

4. WATER PRESSURE For every 33 feet a scuba diver descends below the surface of the water, the water pressure increases by about 15 pounds per square inch. A diver reaches the bottom of a lake that is 99 feet deep. What is the water pressure?

STOCKS For Exercises 5–7, use the information in the table below.

Company Z is selling stock in its company for the first time. The initial selling price for the stock was \$33.00. The table below shows the selling price throughout the morning of the first day.

Stock Z	
Time	Price
9:00 A.M.	\$33.00
10:00 A.M.	\$30.00
11:00 A.M.	\$27.00
12:00 P.M.	\$24.00

5. How would you describe the rate of change in price per hour?

6. If this rate stays constant, how much would the stock lose in 5 hours?

7. If this rate stays constant, how many more hours will it take for this stock to be worthless?

2-5 Practice: Problem Solving***Dividing Integers***

1. ELEVATOR Hans is at the observatory of the Empire State Building in New York City. The observatory is on the 86th floor of the building. Hans will take the elevator down from the 86th floor to the first floor, an approximate distance of 300 meters. The ride takes 50 seconds to descend. What is the approximate rate of descent in meters per second?

2. TEMPERATURE Lydia and her family live in Canada. During the month of February, Lydia recorded the average daily temperature for one week. Her results are shown in the table below. What was the average for that week?

Sun	Mon	Tue	Wed	Thu	Fri	Sat
-3°C	-4°C	0°C	-2°C	0°C	3°C	-1°C

3. ENERGY Most energy produced in the industrialized world comes from fossil fuels. The table below shows the energy production from fossil fuels in the United States for 2000. What was the average total energy produced from fossil fuels per month? Round to the nearest tenth.

Source	British thermal units (Btu) (in quadrillions)
Coal	23
Natural Gas	20
Crude Oil	12

Source: www.eia.doe.gov/emeu/aer/eh/frame.html

Hint: To find the average, add the Btu's and divide by 3

4. SKYDIVING The time an object is in freefall is given by the formula $t = \frac{v}{2g}$ where v is the final velocity, g is gravitational constant of 32 ft/sec² and t is the time of the fall. A skydiver jumps out of a plane at 6000 feet. How long does it take to reach the final velocity of -96 feet per second?

5. STOCK MARKET During a 5-day work-week, the stock market decreased by 65 points. The stock market changed by the same amount each day. What was the change on the first day?

6. WEATHER Over the past seven days, Mrs. Cho found that the temperature outside had dropped a total of 35 degrees. The temperature changed by the same amount each day. What was the change on the last day?

7. POPULATION The enrollment at Davis Middle School dropped by 60 students over a 5-year period. The enrollment dropped by the same amount each year. What was the yearly change?

8. MOTION Mr. Diaz decreased the speed of his car by 30 miles per hour over a period of 10 seconds. Suppose the speed decreased the same amount each second. How many miles per hour does it decrease in the first second?

2-6 Practice: Problem Solving

Problem-Solving Strategy: Look for a Pattern

1. HEIGHT Fernando is 2 inches taller than Jason. Jason is 1 inch shorter than Kendra. Hao, who is 5 feet 10 inches tall, is 3 inches taller than Fernando. How tall is each student?

2. FRUIT The table below shows the results of a survey of students' favorite fruit. How many more students like apples than bananas?

Favorite Fruit							
A	B	G	B	A	B	A	O
O	A	G	G	G	A	A	B
G	O	A	B	O	B	O	O

A = apple B = banana G = grapes
O = orange

3. MONEY Beng borrowed \$120 from his uncle to buy a music player. Each week he makes a payment on the loan. If this pattern continues, how many weeks will it take for Beng to repay the loan?

Week	Week 1	Week 2	Week 3
Balance	-120	-112	-104

4. BOOKS An author has written 4 different books. Each book is available in hard bound, soft bound, and on tape. How many different items are available by this author?

5. FOOTBALL The varsity football team scored 24 points in last Friday's game. They scored a combination of 7-point touchdowns and 3-point field goals. How many touchdowns and how many field goals did they score?

6. CYCLING Jody and Lazaro are cycling in a 24-mile race. Jody is cycling at an average speed of 8 miles per hour. Lazaro is cycling at an average speed of 6 miles per hour. If they both started the race at the same time, who will finish first? How much faster will he or she finish the race?

2-7

Practice: Problem Solving

Solving Equations

Write an equation for each problem. Solve.

- 1. DISTANCE** Route 27 runs from Bakersville to Malden through Smilyville. The distance from Bakersville to Smilyville is 81 miles, and the distance from Bakersville to Malden is 204 miles. What is the distance from Smilyville to Malden?

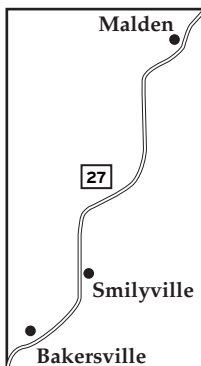

- 4. ASTRONOMY** The table shows the mean distances in kilometers from the Sun to several planets. If a rocket is traveling at 32,000 kilometers per hour, how long would it take the rocket to travel from Earth to Saturn?

Planet	Mean distance to the Sun (kilometers)
Earth	149,600,000
Mars	227,900,000
Saturn	2,870,000,000

Source: NASA Solar System Exploration

- 2. BASEBALL** After $8\frac{1}{2}$ innings, the Cubs are winning the baseball game. How many runs must the Mariners score in the bottom of the ninth inning if they want to win the game?

	Innings				
	1-5	6	7	8	9
Cubs	1	2	0	5	3
Mariners	4	1	2	2	

- 3. DISTANCE** Josh and his brother will drive from Boston to New York, a distance of 220 miles. If they drive an average speed of 55 miles per hour, how long will it take Josh and his brother to arrive in New York?

TRAVEL For Exercises 5 and 6, use the following information.

Four members of the Kaplan family will take a river trip down the Colorado River in Colorado State Park. The rafting company charges \$10 per day to rent the raft and \$15 per person for a half-day river trip, or \$100 flat rate for a half-day river trip. The raft can hold up to 10 people.

- 5.** How much will the trip cost the Kaplan family at the per person rate?
- 6.** How many people must be on the river trip to make the flat rate less expensive than the per person rate?

3-1 Practice: Problem Solving***Fractions***

<p>1. SHOES Toya is looking in her closet. If $\frac{1}{5}$ of her shoes are black and $\frac{2}{5}$ are brown, does she have more black shoes or more brown shoes? Explain.</p>	<p>2. BUDGET Daniel spends $\frac{3}{10}$ of his money on rent and $\frac{4}{10}$ of his money on food. Does he spend more money on food or rent? Explain.</p>
<p>3. WOODWORKING Isi drilled a hole that is $\frac{3}{6}$ inch wide. She has a screw that is $\frac{5}{6}$ inch wide. Is the hole wide enough to fit the screw? Explain.</p>	<p>4. FOOD In a recent survey, $\frac{7}{10}$ of the people surveyed said their favorite food was pizza, $\frac{1}{10}$ said it was hot dogs, and $\frac{2}{10}$ said it was popcorn. Which food was favored by the greatest number of people? Explain.</p>
<p>5. OFFICE SUPPLIES A blue paper clip is $\frac{1}{6}$ inch wide. A silver paper clip is $\frac{3}{6}$ inch wide, and a red paper clip is $\frac{2}{6}$ inch wide. What color paper clip has the smallest width? Explain.</p>	<p>6. GUMBALLS A red gumball is $\frac{3}{8}$ inch across. A green gumball is $\frac{7}{8}$ inch across, and a blue gumball is $\frac{5}{8}$ inch across. List the gumballs in order from smallest to largest.</p>

3-2**Practice: Problem Solving*****Fractions and Mixed Numbers***

<p>1. MILEAGE Brownsville is $\frac{61}{8}$ miles away from Frisco. Write the distance as a mixed number.</p>	<p>2. SWIMMING Steven swam $\frac{47}{6}$ meters crossing Lady Jay Creek. Write the distance he swam as a mixed number.</p>
<p>3. FOOD Kenji's favorite recipe calls for $\frac{15}{4}$ cups of flour. Write the amount of flour he needs as a mixed number.</p>	<p>4. PUPPY Nikki's puppy weighs $\frac{25}{7}$ pounds. Write the puppy's weight as a mixed number.</p>
<p>5. EXERCISE Koto can run $\frac{47}{10}$ miles before she is too tired to keep going. Write the distance she can run as a mixed number.</p>	<p>6. GEOGRAPHY Hampshire Hill is $\frac{87}{9}$ meters tall. Write its height as a mixed number.</p>

3-3**Practice: Problem Solving*****Factors and Simplifying Fractions***

<p>1. WAREHOUSE A warehouse has three shelves that can hold 8, 12, or 16 skateboards. Each shelf has sections holding the same number of skateboards. What is the greatest number of skateboards that can be put in a section? Explain.</p>	<p>2. FRUIT Mei has 15 oranges, 9 peaches, and 18 pears. She wants to put all of the fruit into decorative baskets. Each basket must have the same number of pieces of fruit in it. Without mixing fruits, what is the greatest number of pieces of fruit Mei can put in each basket? Explain.</p>
<p>3. SHIPPING Oscar needs to ship 14 rock CDs, 12 classical CDs, and 8 pop CDs. He can pack only one type of CD in each box, and he must pack the same number of CDs in each box. What is the greatest number of CDs Oscar can pack in each box? Explain.</p>	<p>4. PRESIDENTS Of the first 22 presidents, 8 were from New York. Write the number of presidents from New York as a fraction of the first 22 presidents in simplest form.</p>
<p>5. BICYCLES A local community college has 860 students. Of these 860 students, 220 ride bicycles. Write the number of bike riders as a fraction of the number of students at the college in simplest form.</p>	<p>6. SPORTS La Toya collects baseball cards. Her collection has 200 cards. Of these 200 cards, 50 are soccer cards. Write the number of soccer cards as a fraction of La Toya's total number of cards in simplest form.</p>

3-4

Practice: Problem Solving

Problem-Solving Strategy: Draw a Diagram

Draw a diagram to solve each problem.

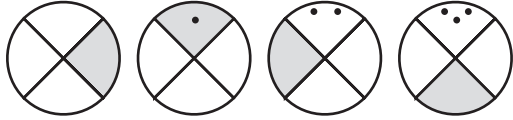
<p>1. MONEY Chantel has \$200 in her checking account. She wants to spend $\frac{1}{2}$ of her money on clothes. She also wants to spend $\frac{1}{2}$ of the remaining money on school supplies. How much will she spend on school supplies?</p>	<p>2. GEOMETRY Draw the next three figures in the pattern.</p> 												
<p>3. PIZZA Olivia has eaten $\frac{1}{3}$ of the pizza. Suppose she has eaten 3 pieces. How many pieces were originally in the pizza?</p>	<p>4. EXERCISE Katlyn runs 2 miles after school each day, 3 miles on Saturday and 4 miles on Sunday. How many miles does she run during one week?</p>												
<p>5. WORK Jefferson wants to work at least 25 hours this week. Suppose he has already worked 22 hours. How many hours does he need to work on Saturday?</p>	<p>6. TRAVEL The bus to Washington has traveled $\frac{5}{6}$ of the way there. The bus has traveled 80 miles. How much farther does it have to go?</p>												
<p>7. MUSEUMS The Art Club is planning on attending a museum. The museum has 50 modern art paintings. Of the 50 modern paintings, 15 are by Spanish artists. What fraction of the paintings are by Spanish artists?</p>	<p>8. SPORTS Janean made 50 baskets during the week at practice. The table below shows when she made the baskets. How many baskets did she make on Friday?</p> <table border="1" style="margin-left: auto; margin-right: auto; border-collapse: collapse; text-align: center;"> <thead> <tr> <th style="padding: 5px;">Day</th> <th style="padding: 5px;">Number of Baskets</th> </tr> </thead> <tbody> <tr> <td style="padding: 5px;">Monday</td> <td style="padding: 5px;">5</td> </tr> <tr> <td style="padding: 5px;">Tuesday</td> <td style="padding: 5px;">12</td> </tr> <tr> <td style="padding: 5px;">Wednesday</td> <td style="padding: 5px;">16</td> </tr> <tr> <td style="padding: 5px;">Thursday</td> <td style="padding: 5px;">7</td> </tr> <tr> <td style="padding: 5px;">Friday</td> <td style="padding: 5px;">??</td> </tr> </tbody> </table>	Day	Number of Baskets	Monday	5	Tuesday	12	Wednesday	16	Thursday	7	Friday	??
Day	Number of Baskets												
Monday	5												
Tuesday	12												
Wednesday	16												
Thursday	7												
Friday	??												

Copyright © Glencoe/McGraw-Hill, a division of The McGraw-Hill Companies, Inc.

3-5 Practice: Problem Solving***Multiplying Fractions***

COOKING For Exercises 1 and 2, use the recipe for chocolate frosting.

Chocolate Frosting Recipe

$\frac{1}{3}$ cup butter

2 ounces melted unsweetened chocolate

2 cups powdered sugar

$\frac{1}{2}$ teaspoon vanilla

2 tablespoons milk

<p>1. Georgia wants to cut the recipe for chocolate frosting in half for a small cake that she's making. How much of each ingredient will she need?</p>	<p>2. Suppose Georgia wanted to double the recipe; what would the measurements be for each ingredient?</p>
<p>3. COMPUTERS $\frac{1}{5}$ of today's college students began using computers between the ages of 5 and 8. Suppose a college has 3,500 students. How many of the students began using computers between the ages of 5 and 8?</p>	<p>4. EXERCISE A paper published in a medical journal reported that about $\frac{11}{25}$ of girls ages 16 to 17 do not exercise at all. The entire study consisted of about 2,500 girls. About how many did not exercise?</p>
<p>5. ANIMALS Catherine walks her dog $\frac{3}{4}$ mile every day. How far does she walk each week?</p>	<p>6. MUSIC You practice a musical instrument each day for $\frac{2}{3}$ of an hour. How many hours of practice will you get in each week?</p>

3-6 Practice: Problem Solving***Dividing Fractions***

<p>1. PIZZA Norberto has $\frac{9}{10}$ of a pizza. The pizza will be divided equally among 6 people. How much will each person get?</p>	<p>2. CARPENTRY Laura wants to cut a board into three equal pieces. The board is $\frac{5}{8}$ feet long. How long will each piece be?</p>
<p>3. PETS Errol uses $\frac{1}{3}$ can of wet dog food for his dog, Muddy, each day. How many servings will he get from 5 cans of dog food?</p>	<p>4. ICE CREAM Julia ate $\frac{1}{2}$ pint of mint chocolate chip ice cream. Mark ate $\frac{3}{4}$ pint of malt ice cream. How many times more ice cream did Mark eat?</p>
<p>5. GARDENING Talia wants to give away 6 bundles of rosemary from her herb garden. If she has $\frac{1}{2}$ pound of rosemary, how much will each bundle weigh?</p>	<p>6. SCHOOL Kirsten has $\frac{3}{4}$ hour left to finish 5 math problems on the test. How much time does she have to spend on each problem?</p>
<p>7. FOOD Joe has $\frac{1}{2}$ of a cake he would like to split among 3 people. What part of the cake will each person get?</p>	<p>8. INTERNET $\frac{3}{4}$ of college students use the Internet more than the library. $\frac{9}{100}$ use the library more. How many times more students use the Internet?</p>

3-7

Practice: Problem Solving

Adding and Subtracting Fractions with Like Denominators

MAPS For Exercises 1–3, use the drawing at the right that shows distances between major sites on the Avenue of the Americas in New York City.

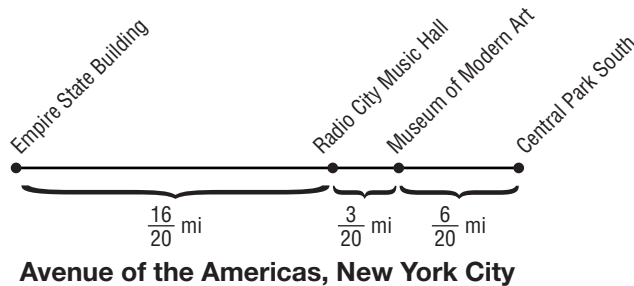

<p>1. Carla walked from the Empire State Building to the Museum of Modern Art. How far did she walk?</p>	<p>2. Julie walked from Central Park South to the Museum of Modern Art. Jolene walked from Radio City Music Hall to the Museum. How much farther did Julie walk than Jolene?</p>
<p>3. Darnell walked from Central Park South to the Empire State Building. How far did he walk?</p>	<p>4. COOKING Tiffany made a glass of punch from fruit juice concentrate. She used $\frac{1}{4}$ cup concentrate and $\frac{3}{4}$ cup water. How much more water than concentrate did Tiffany use?</p>
<p>5. ART Beng is creating a painting. He has $\frac{5}{8}$ of a tube of red paint and $\frac{3}{8}$ of a tube of green paint. How much more red paint does he have than green paint?</p>	<p>6. CONSTRUCTION Mr. Hayashi is repairing his sidewalk. He mixed $\frac{5}{9}$ pound of cement with sand and water to make concrete. The next day he mixed $\frac{7}{9}$ pound of cement with sand and water. How many pounds of cement altogether did Mr. Hayashi use?</p>

Copyright © Glencoe/McGraw-Hill, a division of The McGraw-Hill Companies, Inc.

3-8 Practice: Problem Solving***Adding Fractions with Unlike Denominators***

RETAIL STORES For Exercises 1–4 use the table below. It shows what fraction of the stores at a mall fall into seven categories.

Type of Store	Fraction of Stores in Mall
jewelry	$\frac{1}{30}$
clothing	$\frac{8}{15}$
gifts	$\frac{3}{20}$
electronics	$\frac{1}{20}$
department	$\frac{1}{15}$
shoes	$\frac{1}{15}$
athletic	$\frac{1}{10}$

1. What fraction of the stores are jewelry or gift stores?	2. What fraction of the stores are clothing or electronics stores?
3. Which type of store has the greatest number of stores?	4. How many more clothing stores are there than athletic stores? Write as a fraction.
5. SEWING Jin wants to make a scarf and matching hat for his sister. The patterns call for $\frac{7}{8}$ yard of fabric for the scarf and $\frac{1}{2}$ yard of fabric for the hat. How much fabric should Jin buy?	6. RESTAURANT Ms. Malle owns a restaurant. On Monday, $\frac{1}{5}$ of the customers order fish and $\frac{1}{4}$ of the customers order poultry. What fraction of her customers order either fish or poultry?

3-9**Practice: Problem Solving*****Subtracting Fractions with Unlike Denominators***

BUSINESS For Exercises 1–4, use the table below. It lists the fractions of United States car sales held by several companies in 2005.

Leading Car Sales in U.S. in 2005	
Company	Fraction of Sales
Company A	$\frac{1}{5}$
Company B	$\frac{4}{25}$
Company C	$\frac{2}{5}$
Company D	$\frac{3}{20}$

<p>1. How much greater was the fraction of the market of Company A than Company B?</p>	<p>2. How much greater was the fraction of the market of Company A than of Company D?</p>
<p>3. How much more than Company A's fraction of the market did Company C have?</p>	<p>4. How much more than Company D's fraction of the market did Company B have?</p>
<p>5. TRAVEL Gabriella's travel shampoo bottle holds $\frac{1}{2}$ cup of shampoo. Before leaving on vacation, she filled the bottle to the top with $\frac{1}{8}$ cup of shampoo. How much shampoo was already in the bottle?</p>	<p>6. EXERCISE Bill and Andy were racing to see who could run the farthest in 5 minutes. Bill ran $\frac{5}{8}$ of a mile. Andy ran $\frac{3}{4}$ of a mile. How much farther did Andy run than Bill?</p>

3-10 Practice: Problem Solving***Fractions in Expressions and Equations***

<p>1. BIKING Brandon can ride his bike 4 miles in $\frac{3}{5}$ of an hour. The speed s that Brandon can ride his bike is given by the equation $4 = \frac{3}{5}s$. What is Brandon's speed?</p>	<p>2. BAND The woodwind section of the middle school band makes up $\frac{1}{4}$ of the band. There are 9 members in the woodwind section. Use the equation $\frac{1}{4}m = 9$ to find the number of members m in the band.</p>
<p>3. SALE A coat is selling for $\frac{3}{4}$ of the original price. The sale price is \$180. The original price p can be found using the equation $\frac{3}{4}p = 180$. Find the original price.</p>	<p>4. SALARIES Aaron's annual salary is $\frac{2}{3}$ as much as Juanita's salary. Aaron makes \$46,000. Find Juanita's salary x using the equation $46,000 = \frac{2}{3}x$.</p>
<p>5. ENDANGERED SPECIES In the U. S., there are $\frac{14}{29}$ as many endangered species of birds as of reptiles. The number of endangered species of birds b can be compared to the 14 endangered species of reptiles using $\frac{14}{29}b = 14$. Find the number of endangered species of birds.</p>	<p>6. CONSUMERISM Corey had $\frac{3}{8}$ of a tank of gas in his car. He just bought \$14 worth of gas. Now he has $\frac{2}{3}$ of a tank of gas. What fraction of the tank did Corey fill with gas?</p>
<p>7. SPEED Ella rode the bus to work today. The distance she traveled was $4\frac{1}{4}$ miles. The ride took $\frac{1}{3}$ of an hour. The equation $\frac{1}{3}s = 4\frac{1}{4}$ can be used to find the speed s of the bus. What was the speed of the bus?</p>	<p>8. SAVINGS Jasmine saves \$46 each month from her part-time job. She saves $\frac{2}{5}$ of her earnings. Her earnings a can be found by using the equation $\frac{2}{5}a = 46$. Find her earnings.</p>

4-1 Practice: Problem Solving***Fractions and Decimals***

<p>1. BOYS AND GIRLS There were 6 girls and 18 boys in Mrs. Johnson's math class. Write the number of girls as a fraction of the number of boys. Then write the fraction as a repeating decimal.</p>	<p>2. CATS In a neighborhood of 72 families, 18 families own one or more cats. Write the number of families who own one or more cats as a fraction. Then write the fraction as a decimal.</p>
<p>3. CELLULAR PHONES In Italy, about 74 of every 100 people use cellular telephones. Write the fraction of cellular phone users in Italy. Then write the fraction as a decimal.</p>	<p>4. FRUITS Ms. Rockwell surveyed her class. She found that 12 out of the 30 students chose peaches as their favorite fruit. Write the number of students who chose peaches as a fraction in simplest form. Then write the fraction as a decimal.</p>
<p>5. TRAVEL Tora took a short trip of 320 miles. He stopped to have lunch after he had driven 120 miles. Write the distance he had completed by lunch as a fraction in simplest form. Then write the fraction as a decimal.</p>	<p>6. VOTING In a recent school election, 208 of the 325 freshmen voted in their class election. Write the fraction of freshmen who voted. Then write the fraction as a decimal.</p>

4-2 Practice: Problem Solving***Adding and Subtracting Decimals***

<p>1. MICE The average length of the head and body of a western harvest mouse is 2.9 inches. The average length of the tail is 2.8 inches. First, estimate the total length of the mouse. Then find the actual total length.</p>	<p>2. MUSIC A piano solo on a CD is 5.33 minutes long. A guitar solo is 9.67 minutes long. How much longer is the guitar solo than the piano solo? First estimate the difference. Then find the actual difference.</p>
<p>3. WHALES The average length of a humpback whale is 13.7 meters. The average length of a killer whale is 6.85 meters. How much longer is the humpback whale than the killer whale?</p>	<p>4. GARDENING Alan is connecting three garden hoses to make one longer hose. The green hose is 6.25 feet long. The orange hose is 5.755 feet long. The black hose is 6.5 feet long. First, estimate the total length. Then find the actual total length.</p>
<p>5. ASTRONOMY Distance in space can be measured in astronomical units, or AU. Jupiter is 5.2 AU from the Sun. Pluto is 39.223 AU from the Sun. How much closer to the Sun is Jupiter than Pluto?</p>	<p>6. ALGEBRA It is x miles from James City to Huntley. It is y miles from Huntley to Grover. How many miles is it from James City to Grover? To find out, evaluate $x + y$ if $x = 4.23$ and $y = 16.876$.</p>

4-3 Practice: Problem Solving***Multiplying Decimals***

<p>1. BOWLING A group of friends are going bowling. They bowl a total of 16 games. Each game costs \$2.79. What is the total cost for the bowling?</p>	<p>2. GROCERY SHOPPING Carl and Janna have to buy food for a snack for their class. The granola bars they want to buy cost \$2.29 per box. How much will it cost them to buy the five boxes they need?</p>
<p>3. PETS Ms. Ramos wants to order some identification tags for her 4 pets. If each tag costs \$3.89, what is the total cost?</p>	<p>4. TELEVISION Thirty houses on Devonshire Road have cable television. Suppose cable is priced at \$39.75 per household. How much does it cost for all the houses on Devonshire?</p>
<p>5. FABRIC Noelle is purchasing fabric for something she wants to sew. She needs 6 yards and each yard costs \$7.89. What is the total cost?</p>	<p>6. GAS MILEAGE Raif knows that his car gets 28 miles per gallon of gas. His tank holds 12.6 gallons. How many miles can he travel on one tank of gas?</p>
<p>7. BAKING Ryan and Jill are baking 8 dozen cookies for a school bake sale. It takes them 0.5 hours to make one dozen cookies. How many hours will it take them to make 8 dozen?</p>	<p>8. FOOTBALL A running back runs an average of 2.5 yards each time he carries the football in the game. Suppose he carries the ball 12 times in the game. How many total yards does he have?</p>

4-4**Practice: Problem Solving*****Dividing Decimals***

<p>1. EGGS A dozen eggs cost \$1.19. About how much does one egg cost?</p>	<p>2. CARPET One-hundred twelve square feet of carpet costs \$368.48. How much does each square foot cost?</p>
<p>3. SHOPPING Carolyn bought 3 boxes of the same cereal at the grocery store, for a total of \$8.79. What was the price of each box?</p>	<p>4. NUTRITION Six apples contain 21 grams of fiber. How much fiber does one apple contain?</p>
<p>5. TRAVELING James' 2,400 mile flight from Los Angeles to Washington, D.C., took 5.5 hours. To the nearest hundredth, how many miles per hour did the plane travel?</p>	<p>6. TEAM Coach Henson picked up the new uniforms for the soccer team. The bill for 15 uniforms was \$989.10. How much did each uniform cost?</p>
<p>7. FUNDRAISER The Parent Teacher Association is hosting a spaghetti dinner as a fundraiser for the school. The ingredients and supplies cost \$232.56, which comes to \$3.42 per person. How many people can they serve with the ingredients and supplies they purchased?</p>	<p>8. BAKERY A baker's dozen doughnuts at the bakery costs \$5.49. A baker's dozen is 13. How much does one doughnut cost to the nearest cent?</p>

4-5 Practice: Problem Solving***Problem-Solving Strategy: Work Backward***

For Exercises 1–3, use the information below.

WEATHER The temperature in Columbus, Ohio on Monday is 35 degrees warmer than it was on Sunday. Saturday's temperature was 7 degrees cooler than Sunday's. At 45 degrees, Friday's temperature was 22 degrees warmer than Saturday's.

For Exercises 4–6, use the table and information below.

MONEY Shelly needs to go to the grocery store to get some items for a dinner party she is hosting with her brother, Preston.

Green Pepper	\$1.79
Flank Steak	\$8.54
Wild Rice	\$3.29
Romaine Lettuce	\$3.79
Cucumber	\$0.99

1. What was the temperature on Monday?	2. Estimate the average temperature for the time period from Saturday to Monday.
3. How many degrees cooler was the temperature on Friday than Monday?	4. How much money should she take to purchase the items contained in the table?
5. Shelly has \$24.00 in her purse before she goes to the store. How much will she have left after she shops?	6. Suppose Preston pays Shelly for half the cost of the groceries. How much does he pay?
7. PATTERNS Find the missing number in the pattern below. $\underline{\quad ? \quad}$ -7, -4, -1, 2	8. PATTERNS Find the missing number in the pattern below. $\underline{\quad ? \quad}$ 8, 32, 128, 512

4-6**Practice: Problem Solving*****Decimals in Expressions and Equations***

Use an equation to solve.

<p>1. GOLF It costs \$12 to attend a golf clinic with a local pro. Buckets of balls for practice during the clinic cost \$3.50 each. How many buckets can you buy at the clinic if you have \$33 to spend?</p>	<p>2. MONEY Paulo has \$145 in his savings account. He earns \$36.75 a week mowing lawns. If Paulo saves all of his earnings, after how many weeks will he have \$439 saved?</p>
<p>3. RETAIL An online retailer charges \$6.99 plus \$0.55 per pound to ship electronics purchases. How many pounds is a DVD player for which the shipping charge is \$11.94?</p>	<p>4. MONEY Caitlin has a \$10 gift certificate to the music store. She has chosen a number of CDs from the \$7.25 bargain bin. If the cost of the CDs is \$33.50 after the gift certificate is credited, how many CDs did Caitlin buy?</p>
<p>5. EMPLOYMENT Mrs. Jackson earned a \$500 bonus for signing a one-year contract to work as a nurse. Her salary is \$22.50 per hour. Her first week's check including the bonus is \$1,220. How many hours did Mrs. Jackson work?</p>	<p>6. PHOTOGRAPHY Morgan subscribes to a website for processing her digital pictures. The subscription is \$5.95 per month and 4 by 6 inch prints are \$0.19 each. How many prints did Morgan purchase if the charge for January was \$15.83?</p>

5-1 Practice: Problem Solving***Exponents***

<p>1. SPORTS In the first round of a local tennis tournament there are 2^5 matches. Find the number of matches.</p>	<p>2. GEOMETRY The volume of a box can be found by multiplying the length, width, and height of the box. The length, width, and height of the cube-shaped box are all 5 inches. Write the volume of the box using an exponent.</p>
<p>3. MONEY An apartment complex has 3 buildings. Each building has 3 apartments. There are 3 people living in each apartment. Each person pays 3 dollars per month for pool maintenance. The expression 3^4 denotes the amount paid each month for pool maintenance. Find this amount.</p>	<p>4. ACTIVISM A petition drive is being held in 10 cities. In each city, 10 people have collected 10 signatures each. The expression 10^3 denotes the number of signatures that have been collected altogether. Find this number.</p>
<p>5. MEASUREMENT There are 10^6 millimeters in a kilometer. Write the number of millimeters in a kilometer.</p>	<p>6. NATURE Suppose a certain forest fire doubles in size every 12 hours. The initial size of the fire was 1 acre. How many acres will the fire cover in 48 hours?</p>
<p>7. BANKING Suppose that a dollar placed into an account triples every 12 years. How much will be in the account after 60 years?</p>	<p>8. BIOLOGY Suppose a bacterium splits into two bacteria every 15 minutes. How many bacteria will there be in 3 hours?</p>

5-2 Practice: Problem Solving***Integer Exponents***

1. SOLAR SYSTEM The distance between Earth and the Sun is about $\frac{1}{100,000}$ the diameter of the solar system. Express this number using a negative exponent other than -1 .

2. PAPER The paper used by the students at Hopkins Middle School is approximately $\frac{1}{216}$ inch thick. Express this number using a negative exponent other than -1 .

3. TIME A microsecond is a measure of time that is equal to one millionth of a second. Express this number as a power of 10 with a negative exponent.

4. MEASUREMENT There are 10^{-2} meters in 1 centimeter. At the site of an automobile accident, a state trooper uses a measuring tape to determine that the width of a tire track is 20 centimeters. Express this number as a fraction of a meter in simplest form.

5. HOMEWORK Libby was working on her math homework. She wrote the following equation on her paper.

$$2^{-3} = -8$$

What was Libby's error? Explain. Then give the correct answer.

INSECTS For Exercises 6–9, refer to the following information.

Kevin's father is an entomologist. He studies insects. The table below shows the mass of four common insects.

Insect	Mass (g)
Honeybee	8^{-2}
Ant	16^{-2}
Housefly	9^{-2}
Moth	4.5^{-2}

6. Express each of the masses in decimal form. Round your answers to the nearest thousandth. Then, determine which of these insects weighs the most.

7. How many times heavier is the heaviest insect than the lightest insect? Round your answer to the nearest tenth.

8. It is estimated that an ant can lift approximately 20 times its own body mass. How many grams can the average ant lift? Write your answer as a fraction in simplest form.

5-3 Practice: Problem Solving***Problem-Solving Strategy: Solve a Simpler Problem***

Use an equation to solve Exercises 1–3. Use any strategy to solve Exercises 4–6.

<p>1. NUMBERS Find the sum of the whole numbers from 1 to 100.</p>	<p>2. Teresa and her six friends are packing for a trip. Each girl is bringing 4 blouses, 3 jackets, and 2 pairs of jeans. Each girl will wear only the clothes she packs. How many total outfits can be created?</p>										
<p>3. MONEY Each day Robert does his chores, he earns triple the amount of money. On the first day, Robert earns 1 penny. On the second day, he earns 3 pennies. On the third day, he earns 9 pennies. How much total money will he have after 10 days?</p>	<p>4. TRAVEL Mr. Ishikawa left Houston at 3:00 P.M. and arrived in Dallas at 8:00 P.M., driving a distance of approximately 240 miles. During his trip, he took a one-hour dinner break. What was Mr. Ishikawa’s average speed?</p>										
<p>5. BAKE SALE Oakdale Middle School received 240 contributions for its bake sale. If 30% of the contributions were pies, how many pies did the school receive?</p>	<p>6. BABY-SITTING About how much more did Cara earn baby-sitting in 2005 than in 2004?</p> <table border="1" data-bbox="810 1549 1318 1780"> <thead> <tr> <th colspan="2">Cara’s Baby-Sitting Earnings</th> </tr> <tr> <th>Year</th> <th>Earnings</th> </tr> </thead> <tbody> <tr> <td>2003</td> <td>\$98.50</td> </tr> <tr> <td>2004</td> <td>\$149.00</td> </tr> <tr> <td>2005</td> <td>\$218.75</td> </tr> </tbody> </table>	Cara’s Baby-Sitting Earnings		Year	Earnings	2003	\$98.50	2004	\$149.00	2005	\$218.75
Cara’s Baby-Sitting Earnings											
Year	Earnings										
2003	\$98.50										
2004	\$149.00										
2005	\$218.75										

5-4 Practice: Problem Solving**Roots**

1. LIFEGUARDS Maria is a lifeguard in Port Aransas. When she sits in her chair, her eyes are 9 feet off the ground. On a clear day, how far can Mary see from her chair? Use the equation $D = 1.22 \times \sqrt{A}$, where D is the distance in miles to the horizon at a height of A feet.

2. CONSTRUCTION José is building a square deck off of the back of his house. He has a building permit for a 441-square foot deck. How long will each side of the deck be?

3. BASEBALL The area of a little league diamond is 3,600 square feet. The infield for a regulation-sized baseball diamond is 8,100 square feet. How much farther is it from first base to second base on the regulation-sized field than on a little league field?

4. GARDENING Jordan wants to fill a square flower bed with 24 perennials. The landscaper recommends that he allow 1.5 square feet per plant. What should the length of one side of the flower bed be?

PHYSICS For Exercises 5–7, use the following information. Round your answers to the nearest hundredth.

The time it takes for a pendulum to swing back and forth one time is called the period of the pendulum. For a pendulum of length L (in feet), the period T (in seconds) is given

by the equation $T = \frac{1}{2}\pi\sqrt{\frac{L}{2}}$.

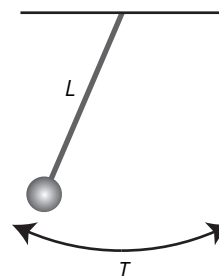

5. What is the period of a pendulum that is 2 feet long?

6. What is the period of a pendulum that is 8 feet long?

7. In general, what do you think will happen to the period of a pendulum if the length of the pendulum is quadrupled? Explain.

5-5 Practice: Problem Solving

Simplifying and Evaluating Expressions

- GEOMETRY** Mr. Daniels is building a clubhouse for his children. He has decided that the floor will be a square with an area of 64 square feet. Write the number by using a positive exponent.
- STOCK MARKET** The Nikkei 225 is a stock market index that records the progress of 225 Japanese companies. Write the number 225 using a positive exponent.
- NUMBER SENSE** A *googol* is a very large number expressed as 10^{100} . Ms. Rogers asked her students to determine which number is larger, a googol or 100^{10} . Explain how her students might use the idea of repeated factors in order to find the solution.
- LIFE SCIENCE** A scientist is studying bacterial growth in the laboratory. She starts her experiment with 1 bacterium. She then counts the bacteria at regular intervals and records the data in the table below. If the pattern continues, how long will it take to have over 1,000 bacteria?

Time (hours)	0	3	6	9
Number of cells	1	2	4	8

GEOMETRY For Exercises 5 and 6, use the following information.

A right triangle has two legs that form a 90° angle. The side opposite the right angle is called the hypotenuse. Let a and b represent the lengths of the legs. Let c represent the length of the hypotenuse. The formula $c = \sqrt{a^2 + b^2}$ shows the relationship between the legs and the hypotenuse.

- The following diagram shows a ladder leaning against a wall. The bottom of the ladder is 5 feet from the base of the wall, and the ladder reaches 12 feet up the wall. Find the length of the ladder.

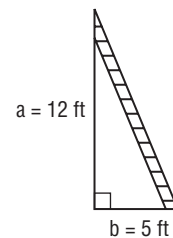

- Paula exercises regularly by power walking around a rectangular field. She usually begins at one corner of the field and walks the full perimeter. One day, she takes a shortcut home by walking across the diagonal of the field. How far does she walk across the field?

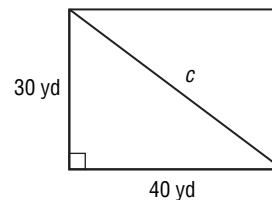

5-6 Practice: Problem Solving***Comparing and Ordering Rational Numbers***

<p>1. BASKETBALL In the last ten games, Percy made $\frac{7}{12}$ of his free throws. For the same period, Tariq made $\frac{4}{7}$ of his free throws. Which player has the better free throw record?</p>	<p>2. SPORTS Central's baseball team won $\frac{53}{78}$ of its games last year, while Southern's team won $\frac{55}{81}$ of its games. Which team had the better record?</p>
<p>3. MEASUREMENT Beaker A contains $4\frac{1}{3}$ fluid ounces of water, while Beaker B contains $\frac{43}{10}$ fluid ounces of water. Which beaker has the smaller amount of water?</p>	<p>4. NATURE The two trees in Opal's back yard have circumferences of $\frac{101}{8}$ inches and $12\frac{3}{5}$ inches. Which circumference is larger?</p>
<p>5. EXERCISE On Monday, Rob averaged 3.75 laps per minute. On Tuesday, he averaged $3\frac{4}{5}$ laps per minute. On which day did Rob run faster?</p>	<p>6. FOOD Hector and Carla both gave apples to their teacher. Hector's apple weighed $6\frac{7}{12}$ ounces, while Carla's apple weighed 6.65 ounces. Which apple weighed more?</p>
<p>7. NUMBER SENSE Order the following numbers from least to greatest? $3\frac{1}{5}$, 3.25, 2^2, $\sqrt{9}$</p>	<p>8. STATISTICS The median of a set of numbers can be found by first putting the numbers in order from least to greatest, then choosing the middle number. Find the median of 5.79, $\sqrt{25}$, $5\frac{7}{8}$, 3^2, and $5\frac{4}{5}$.</p>

6-1 Practice: Problem Solving***Ratios and Rates***

<p>1. FOOTBALL In the NFL 2004–2005 season, the Miami Dolphins won 4 games and the Oakland Raiders won 5 games. What is the ratio of wins for the Dolphins to wins for the Raiders?</p>	<p>2. GARDENING Rod has 10 rosebushes, 2 of which produce yellow roses. Write the ratio <i>2 yellow rosebushes out of 10 rosebushes</i> in simplest form.</p>
<p>3. TENNIS Nancy and Lisa played 20 sets of tennis. Nancy won 12 of them. Write the ratio of Nancy’s wins to the total number of sets in simplest form.</p>	<p>4. AGES Oscar is 16 years old and his sister Julia is 12 years old. What will be the ratio of Oscar’s age to Julia’s age in 2 years? Write as a fraction in simplest form.</p>
<p>5. MOVIES Four friends paid a total of \$32 for movie tickets. What is the ratio <i>\$32 for 4 people</i> written as a unit rate?</p>	<p>6. WORKING At a warehouse, the employees can unload 18 trucks in 6 hours. What is the unit rate for unloading trucks?</p>
<p>7. ANIMALS A reindeer can run 96 miles in 3 hours. At this rate, how far can a reindeer run in 1 hour? Explain.</p>	<p>8. SHOPPING Jenny wants to buy cereal that comes in large and small boxes. The 32-ounce box costs \$4.16, and the 14-ounce box costs \$2.38. Which box is less expensive per ounce? Explain.</p>

6-2

Practice: Problem Solving

Fractions, Decimals, and Percents

INTERNET For Exercises 1–4, use the table. It shows the percents of online shopping purchases made by all Internet users and the percents made by Internet users over age 55.

Most Popular Online Purchases		
	Internet Users Over 55	All Internet Users
computer software	43%	19%
books	43%	21%
computer hardware	24%	13%
music CDs	29%	22%
clothing	19%	8%

<p>1. What fraction of Internet users over 55 bought clothing online?</p>	<p>2. What fraction of all Internet users bought clothing online?</p>
<p>3. What fraction of all Internet users bought music CDs online?</p>	<p>4. Is the fraction of Internet users over 55 who bought books online greater or less than $\frac{22}{50}$? Explain.</p>
<p>5. FOOTBALL In 2001 San Francisco quarterback Jeff Garcia completed 316 out of 504 passes. What was his pass completion percentage to the nearest tenth?</p>	<p>6. COMPUTERS In Joan’s math class, there are 20 computers and 32 students. What percent of students will be able to use a computer without sharing?</p>
<p>7. VEHICLES In the town of Orick, 5 out of 13 vehicles are trucks. What percent of the vehicles are trucks? Round to the nearest tenth.</p>	<p>8. DENTISTRY Dana has fillings in 4 of her 32 teeth. What percent of her teeth have fillings?</p>

Copyright © Glencoe/McGraw-Hill, a division of The McGraw-Hill Companies, Inc.

6-3 Practice: Problem Solving***Proportions and Proportional Reasoning***

1. RUNNING Donna is planning to run a 13.1-mile half marathon. She tells of her plans to her European friend, who asks how many meters she will run. There are approximately 1609 meters in 1 mile. Write a proportion that could be used to find the distance of the marathon in meters.

2. FLOWERS The Tyler Municipal Rose Garden and Center in Tyler, Texas, is the nation's largest rose garden. It contains 38,000 rose bushes representing 500 varieties of roses set in a 14-acre park. Write a proportion that could be used to find the average number of rose bushes per acre.

3. RECYCLING Ohio is the home of two of the world's largest aluminum smelters, in which metal is separated for recycling. Together, these two facilities process an average of 15 million pounds of aluminum each month. How many pounds of aluminum do the Ohio smelting plants average per week?

4. TECHNOLOGY Elton just bought a new flash drive for his computer. He read in the literature that 7 flash drives can hold 1792 megabytes of data. Write and solve a proportion to find the number of megabytes of data that 5 flash drives can hold.

COOKING For Exercises 5 and 6, use the following information.

Ashley is planning breakfast for a family event. She wants to serve Deltan Waffles. She found this recipe, which serves 8 people.

Deltan Waffles	
$1\frac{3}{4}$ cups flour	$1\frac{1}{4}$ cups milk
$\frac{1}{2}$ teaspoon salt	$\frac{1}{2}$ cup shortening, melted
1 tablespoon baking powder	
2 egg yolks	2 egg whites

5. How much salt does she need if she uses 3 eggs?

6. How much baking powder does she need if she wants to serve 12 people?

6-4 Practice: Problem Solving***The Percent Proportion***

<p>1. DRIVING David installed a device on his car that guaranteed to increase his gas mileage by 15%. He currently gets 22 miles per gallon. How much will the gas mileage increase after installing the device?</p>	<p>2. POPULATION The number of students at Marita's school decreased to 98% of last year's number. Currently, there are 1,170 students. How many students were there last year? Round to the nearest whole number.</p>
<p>3. VOTING Yolanda's club has 35 members. Its rules require that 60% of them must be present for any vote. At least how many members must be present to have a vote?</p>	<p>4. GARBAGE This month, Chun's office produced 690 pounds of garbage. Chun wants to reduce the weight of garbage produced to 85% of the weight produced this month. What is the target weight for the garbage produced next month?</p>
<p>5. SALARIES Alma just received a 6% raise in salary. Before the raise, she was making \$52,000 per year. How much more will Alma earn next year?</p>	<p>6. SPORTS Sally's soccer team played 25 games and won 17 of them. What percent did the team win?</p>

6-5 Practice: Problem Solving***Problems Involving Percents***

<p>1. COMPUTERS The computer store pays \$250 each for flat screen monitors. The store uses a 30% markup. Find the selling price for each flat screen monitor.</p>	<p>2. SHOES A popular brand of running shoes costs a local store \$68 for each pair. Find the selling price for a pair of running shoes if the store has a markup of 75%.</p>
<p>3. RETIREMENT Han has \$410,000 in a retirement account that earns \$15,785 each year. Find the simple interest rate for this investment.</p>	<p>4. COLLEGE FUND When Melissa was born, her parents put \$8,000 into a college fund account that earned 9% simple interest. Find the total amount in the account after 18 years.</p>
<p>5. MONEY Jessica won \$800,000 in a state lottery. After paying \$320,000 in taxes, she invested the remaining money in a savings account at 4.25% interest. How much interest will she receive from her investment each year?</p>	<p>6. SAVINGS Mona has an account with a balance of \$738. She originally opened the account with a \$500 deposit and a simple interest rate of 5.6%. Suppose there were no deposits or withdrawals. How long ago was the account opened?</p>
<p>7. CLUBS Last year the chess club had 20 members. This year the club has 15 members. Find the percent of change, and state whether the percent of change is an <i>increase</i> or a <i>decrease</i>.</p>	<p>8. READING During Todd's junior year in high school, he read 15 books. In his senior year, he read 18 books. Find the percent of change, and state whether the percent of change is an <i>increase</i> or a <i>decrease</i>.</p>

6-6

Practice: Problem Solving

Direct Variation

Use direct variation to solve.

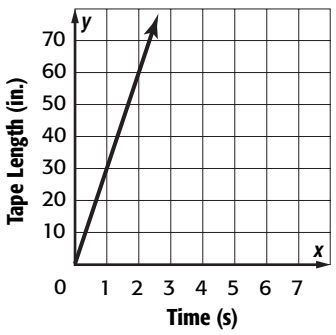
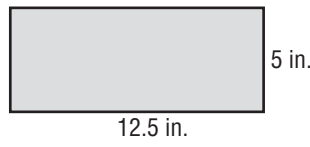
<p>1. y varies directly as x. If $y = 10$ and $x = 2$, find y when $x = 3$.</p>	<p>2. y varies directly as x. If $y = 20$ when $x = 3$, find x when $y = 50$.</p>
<p>3. y varies directly as x. If $y = 14$ and $x = 3$, find y when $x = 4.5$.</p>	<p>4. y varies directly as x. If $y = 7$ when $x = 5$, find x when $y = 21$.</p>
<p>5. DRIVING A car drives 283.5 miles in 4.5 hours. Assuming that the distance traveled is directly proportional to the time traveled, how far will the car travel in 7 hours?</p>	<p>6. MEASUREMENT The number of kilograms that an object weighs varies directly as does the number of pounds. If an object that weighs 45 kilograms weighs about 100 pounds, how many kilograms is an object that weighs 70 pounds?</p>
<p>7. RECORDING The amount of tape that passes through a recording machine varies directly with the amount of time that passes. Determine the speed at which the tape moves.</p> 	<p>8. GEOMETRY The width of a rectangle varies directly as its length. What is the area of a rectangle that is 15 feet long?</p> 

Copyright © Glencoe/McGraw-Hill, a division of The McGraw-Hill Companies, Inc.

6-7 Practice: Problem Solving***Problem-Solving Strategy: Make a Table***

For Exercises 1–4, use the ratio tables below.

Table 1

Cups of Flour	1			
Number of Cookies	30			

Table 2

Number of Books		6	
Cost in Dollars		10	

<p>1. BAKING In Table 1, how many cookies could you make with 4 cups of flour?</p>	<p>2. BAKING In Table 1, how many cups of flour would you need to make 90 cookies?</p>
<p>3. BOOKS In Table 2, at this rate how many books can you buy with \$5?</p>	<p>4. BOOKS In Table 2, at this rate, how much would it cost to buy 9 books?</p>
<p>5. FRUIT Patrick buys 12 bunches of bananas for \$9 for the after school program. Use a ratio table to determine how much Patrick will pay for 8 bunches of bananas.</p>	<p>6. HIKING On a hiking trip, LaShana notes that she hikes about 12 kilometers every 4 hours. If she continues at this rate, use a ratio table to determine about how many kilometers she could hike in 6 hours.</p>

7-1

Practice: Problem Solving

The Coordinate Plane

MONEY For Exercises 1–4, use the table and the coordinate plane.

School buttons sell for \$2 each. When you have completed the table and the graph, both the table and graph will show the costs of purchasing up to 5 school buttons.

Number of Buttons Sold	Price (\$)
1	
2	
3	
4	
5	

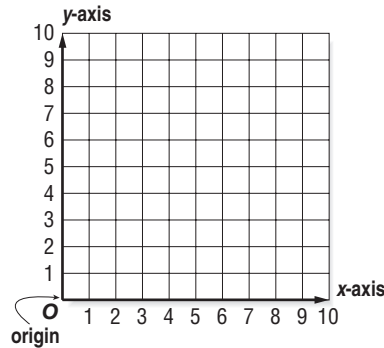

- | | |
|--|---|
| <p>1. Complete the second column of the table by writing the cost of each number of buttons.</p> | <p>2. To prepare to graph the data, make a list of ordered pairs from the table.</p> |
| <p>3. Graph the ordered pairs. Label each point with its ordered pair. Describe the graph of the points.</p> | <p>4. Describe the coordinate plane that you have completed. How is it different from other systems you have used?</p> |
| <p>5. TRACK Trixie takes 8 minutes to run a mile. The expression $8m$ represents her total time where m is the number of miles Trixie has run. List the ordered pairs (number of miles, total time) for 0, 1, 2, and 3 miles.</p> | <p>6. TRACK If you were to graph the ordered pairs from Exercise 5, what would their graph look like?</p> |

7-2 Practice: Problem Solving

Problem-Solving Strategy: Draw a Graph

For Exercises 1–6, use a graph to solve.

- 1. SURVEY** A group of students were asked to name their favorite subject in school. The circle graph shows the results of the survey. If 45 students choose math as their favorite subject, how many students were surveyed?

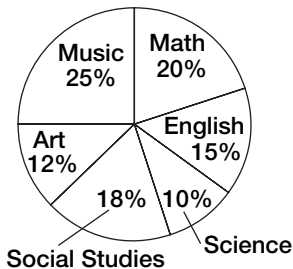

- 2. SALES** The graph shows the monthly sales of George’s Comic Book Shop. Between which two months did sales decrease the most?

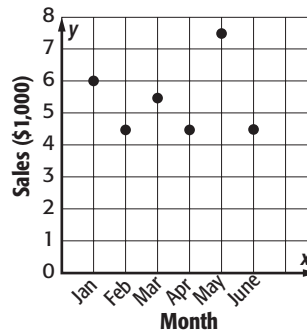

- 3. EXERCISING** Mark runs the mile race at every track meet. The graph shows his times, in minutes, for each meet. Did Mark’s time improve each time that he ran the mile race?

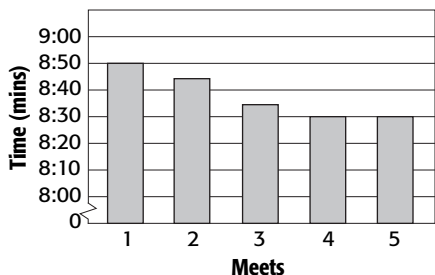

- 4. JOBS** Jerry and four friends mow lawns during summer vacation to earn money. The graph shows how much each earned during each week of vacation. Is there any relationship between the amount that the friends earn each week and the number of the week?

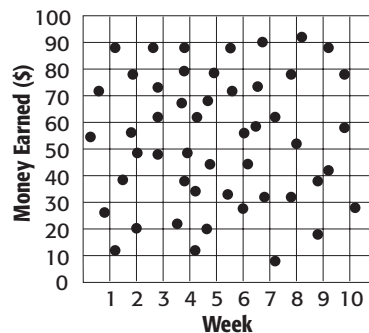

- 5. ART EXHIBIT** The graph shows the number of weekly visitors at an art exhibit. How many more people visited the art exhibit during the week with the most visitors than the week with the least visitors?

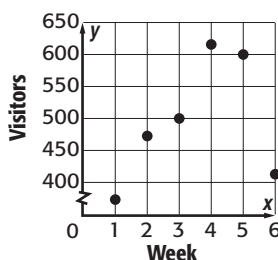

- 6. SURVEY** A group of students were asked to name their favorite color out of four colors. The circle graph shows the results of the survey. If 150 students chose blue as their favorite color, how many students chose green?

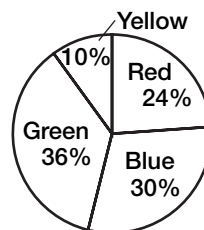

7-3

Practice: Problem Solving

Relationships Involving Equal Ratios

For Exercises 1–3, use the table that shows the relationship between the month of the year and the number of Tamika’s classmates that have their driving permits.

Month	Number of Students
January	1
February	3
March	4
April	5
May	8
June	10
July	11
August	14
September	15
October	15
November	18
December	21

1. Make a scatter plot of the data. Put the months on the horizontal axis and the number of students on the vertical axis.

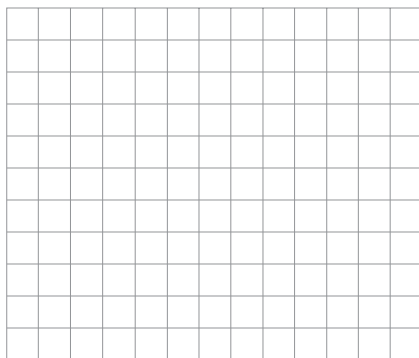

2. Describe the type of relationship there is between the two types of data.
3. Why do you think this relationship exists?

For Exercises 4–5, make a graph to find the answer.

PHOTOGRAPHY A photography store sells black and white film. The cost of 1, 2, and 3 rolls of black and white film are shown in the table.

Black and White Film Costs	
Number of Rolls	Cost (\$)
1	4
2	8
3	12

4. Graph the ordered pairs. Then describe the graph.

EXERCISE The table shows the time it takes Quentin to jog 1, 2, 3, and 4 laps around the track.

Number of Times Around Track	Total Time (min)
1	5
2	10
3	15
4	20

5. Graph the ordered pairs. Then describe the graph.

7-4 Practice: Problem Solving**Measures as Rates and Products**

1. ACADEMICS There are 15 girls and 12 boys in Mrs. Johnson's math class. Suppose each student spent 2 hours studying for an exam. How many student-hours is that?

2. SPORTS The table lists the medal count for the five countries with the most medals in the 2004 Summer Olympics. Write a ratio of the number of gold medals won for the USA to the total number of medals won for the USA.

Country	Gold	Silver	Bronze	Total
USA	35	39	29	103
Russia	27	27	38	92
China	32	17	14	63
Australia	17	16	16	49
Germany	14	16	18	48

3. TRAVEL A family of 6 travels 150 miles on a day trip. How many person-miles do they travel?

4. A family of 7 travels to a museum that is 40 miles away. How many passenger-miles do they travel?

5. RACING Greg Biffle won the Samsung/Radio Shack 500 NASCAR race at the Texas Motor Speedway in April 2005. His average speed was 130 miles per hour. How many feet per second is this?

RECYCLING For Exercises 6–7, use the following information.

In 1974, 23 crushed beverage cans weighed one pound. In 2005, beverage cans were lighter and 33 crushed beverage cans weighed one pound. Every minute of every day, an average of 123,097 beverage cans are recycled.

6. About how many pounds of beverage cans are recycled in an hour?

7. About how many tons of beverage cans are recycled in an average day?

Source: www.dnr.state.oh.us/recycling/awareness/facts/factsheets/aluminum.htm

7-5

Practice: Problem Solving

Slope

- 1. AVIATION** An airplane was at an altitude of 12,000 feet 40 minutes before landing, and at an altitude of 2000 feet 15 minutes before landing. What was the slope of the plane's altitude per minute?
- 2. TICKET SALES** A ticket sales representative at a local water park had \$175.50 in his cash register at the end of his first hour at work. Each ticket to the park cost \$1.75, and he sold an average of one ticket per minute. How much was in his register to start?
- 3. POPULATION** The table shows how residential patterns in the United States have changed over the past 200 years.

Year	Urban Population (per 1000)	Rural Population (per 1000)
1840	108	892
1880	282	718
1920	512	488
1960	631	369
2000	790	210

Source: census.gov

Compare the slopes for each time interval, and describe how the population has changed since 1840.

- 4. STAMPS** Kyuri needs \$0.81 in postage to mail some photographs to a friend. She has 3¢ and 9¢ stamps. The table shows some combinations of 3¢ and 9¢ stamps that she could use to mail the letter. Find the slope between the numbers of 3¢ stamps and 9¢ stamps.

9¢ stamps	3¢ stamps
2	21
3	18
4	15
5	12
6	9

BASEBALL For Exercises 5 and 6, refer to the following information.

This graph shows the total number of runs that the Boston Red Sox scored during the 1996–2004 seasons.

- 5.** Find the greatest slope between two seasons.

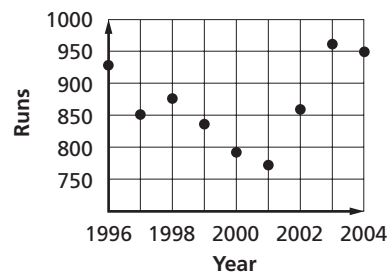

Source: baseball-reference.com

- 6.** Find the average slope from 1996 to 2004.

7-6 Practice: Problem Solving

Linear Functions

1. TEMPERATURE In the United States, temperature is most often measured in degrees Fahrenheit. Temperature is measured in degrees Celsius in the metric system.

The formula used to convert between these two units of measure is

$F = \frac{9}{5}C + 32$, where F represents degrees Fahrenheit and C represents degrees Celsius.

Complete the table. Does this equation represent a *linear* or *nonlinear* function?

C	0	10	20	30	40
F					

2. GASOLINE The table below shows gasoline prices in Springfield during a three-week period. Is the change in gas price a linear function? Explain.

Day of the Month	Price per Gallon
1	\$2.57
4	\$2.72
7	\$2.72
10	\$2.88
13	\$2.88
16	\$2.84
19	\$2.76
21	\$2.72

3. MONEY Marcus earns \$75 when he works 10 hours. He earns \$150 when he works 20 hours. He earns \$187.50 when he works 25 hours. Is Marcus's pay scale linear?

FLIGHT RESEARCH For Exercises 4 and 5, use the following information.

The equation $h = -16t^2 + 608t + 4482$ represents the height, h , in feet, of a pilot over time, t , in seconds, after he or she has ejected from a jet and falls to Earth with the aid of a parachute. A pilot is flying at an altitude of approximately 10,000 feet and is forced to eject from the jet. The equation $h = 10,000$ represents an altitude of 10,000 feet.

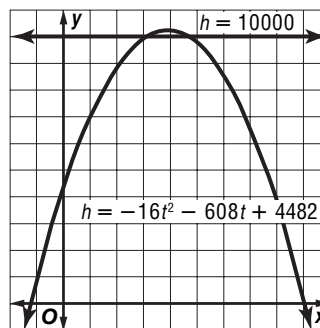

4. Which equation is a linear function?

5. Explain why the other equation is a nonlinear function.

7-7 Practice: Problem Solving**The Pythagorean Theorem**

1. ORIGAMI Chee has a piece of paper measuring 8.5 inches by 8.5 inches. If she folds the paper diagonally in half, how long is the folded side? Round to the nearest tenth.

2. COMPUTERS In a computer catalog, a computer monitor is said to be 19 inches. This distance is the diagonal distance across the screen. If the screen is 10 inches high, what is the width of the screen? Round to the nearest tenth.

3. ANTENNAS A wire 10 meters long is supporting a utility pole. The wire is anchored to the ground and is attached to the pole 9 meters above the ground. What is the distance from the bottom of the pole to the point where the wire is attached to the ground? Round to the nearest tenth.

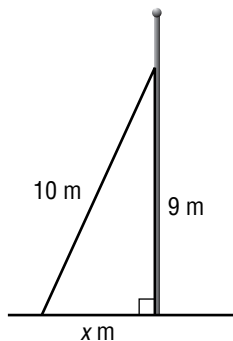

4. RAMPS Crystal wants to build a ramp that will rise 4 feet over a horizontal distance of 20 feet. How long will the ramp be? Round to the nearest tenth.

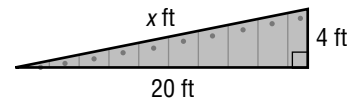

5. POOLS Salomon swims diagonally across his pool every day. If Salomon's pool is 4 meters wide and 16 meters diagonally across, how long is his pool, to the nearest tenth of a meter?

6. FRAMES Rosa has a picture frame that measures 12 inches by 18 inches. What is the diagonal distance across the frame? Round to the nearest tenth.

8-1 Practice: Problem Solving

Triangles and Quadrilaterals

1. TAILORING Each lapel on a suit jacket is in the shape of a triangle. The three angles of each triangle measure 47° , 68° , and 65° . Classify the triangle by its angles.

2. FLAGS A naval distress signal flag is in the shape of a triangle. The three sides of the triangle measure 5 feet, 9 feet, and 9 feet. Classify the triangle by its sides.

3. PARTY The front of a birthday party invitation is shown below. Find the measure of the missing angle.

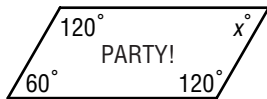

4. TABLE The top of Mr. Bautista's new coffee table is shown below. Find the measure of the missing angle.

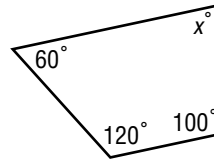

5. HIKING The figure shows the Oak Creek trail, which is shaped like a triangle. Classify the triangle by its angles and by its sides. What is the value of x in the figure?

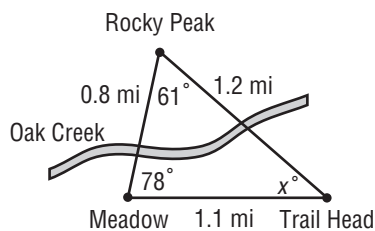

6. LADDER The figure shows a ladder leaning against a wall, forming a triangle. Classify the triangle by its angles and by its sides. What is the value of x in the figure?

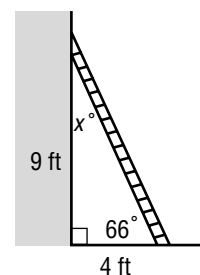

8-2

Practice: Problem Solving

Congruency and Similarity

TILING For Exercises 1–6, use the following information. Amy is using the design at the right to tile a hexagon-shaped floor. Before deciding which colors to use, she wants to identify all similar and congruent shapes.

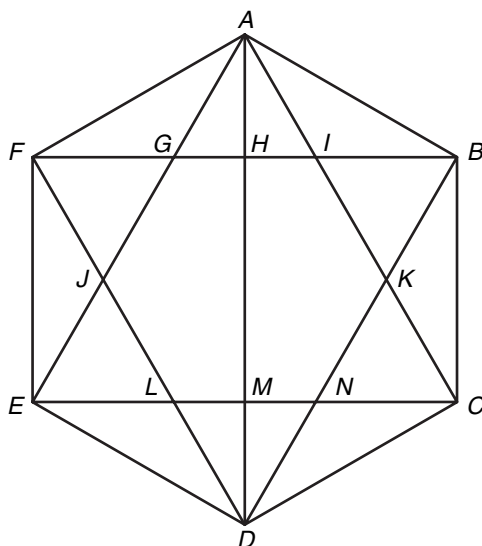

<p>1. Suppose Amy cut a red tile the size of $\triangle ACE$. What other triangle in the design would that tile fit? In other words, what triangle is congruent to $\triangle ACE$?</p>	<p>2. Amy is looking for congruent quadrilaterals that are neither squares nor rectangles. Can you identify them?</p>
<p>3. Find a triangle that is similar to but not congruent to $\triangle BCK$.</p>	<p>4. Amy’s friend suggested that she cut four congruent white triangular tiles and place them in the design so that they are not overlapping and do not share common sides. Is that possible? If so, name the four triangles.</p>
<p>5. Can you help Amy find a shape that is either similar or congruent to $AKDJ$?</p>	<p>6. Is the hexagon $GKLNJ$ similar to $ABCDEF$? How do you know?</p>

Copyright © Glencoe/McGraw-Hill, a division of The McGraw-Hill Companies, Inc.

8-3 Practice: Problem Solving**Coordinate Geometry**

1. MAPS On a map of Joe's hometown, his house is located at $(3, 4)$. His school is located at $(-2, 2)$. How many units are there from Joe's house to his school?

2. CARTOGRAPHY Nicole is looking at a map of an amusement park. The scale is one unit equals 250 feet. The roller coaster is located at $(5, 3)$ and the water slide at $(-2, -1)$. How many feet apart are the two rides? Round to the nearest foot.

3. LANDSCAPING Susan is planting some trees in her front yard. She planted a Bradford pear tree 12 feet west and 1 foot north of her flagpole and planted a Juniper tree 15 feet east and 3 feet north of her flagpole. How far apart are the two trees? Round to the nearest tenth of a foot.

4. HIKING Two scout patrols start hiking in opposite directions. Each patrol hikes 5 kilometers. Then the scouts turn 90° to their right and hike another 6 kilometers. How many kilometers are there between the two scout patrols?

MAPS For Exercises 5–7, use the following information.

Billy and Sam drew a scaled map of their town to determine who lives closer to the Arcade, a favorite weekend meeting place for Billy and Sam. The following grid shows where Billy and Sam live and also where the Arcade is located. Each unit on the grid represents $\frac{1}{2}$ mile.

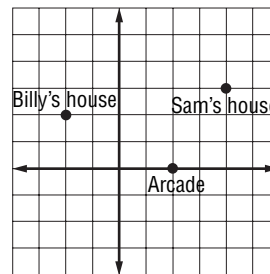

5. How far is Sam's house from the Arcade?

6. How far is Bill's house from the Arcade?

7. How far do Sam and Bill live from one another?

8-4 Practice: Problem Solving**Perimeter**

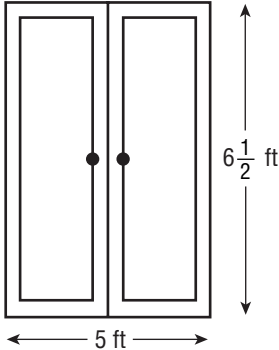
<p>1. PLATES A manufacturing company is producing dinner plates with diameters of 12 inches. They plan to put a gold edge on each plate. Determine how much gold edging they need for each plate by finding the circumference of each plate. Round to the nearest tenth.</p>	<p>2. MONEY A dime has a radius of $8\frac{1}{2}$ millimeters. Find the circumference of a dime to the nearest tenth.</p>
<p>3. MERRY-GO-ROUND Mr. Osterhout is putting trim around the edge of a circular merry-go-round that has a diameter of 15 feet. How much trim does he need to buy to the nearest tenth?</p>	<p>4. PIZZA Find the circumference of a pizza with a diameter of 10 inches. Round to the nearest tenth.</p>
<p>5. BUILD A FENCE Mrs. Chen wants to build a fence around her yard so that her dog, Fluffy, can run free. The yard she wants to fence is 60 feet by 30 feet. The fencing is sold by the linear foot, so in order to figure out how much fencing she needs, Mrs. Chen needs to know the perimeter of the yard. Find the yard's perimeter.</p>	<p>6. WINDOWS Mrs. Johnson was planning to caulk around the frame of her patio doors that measure 5 feet by $6\frac{1}{2}$ feet. In order to help her to know how much caulk to buy, find the perimeter of the doors.</p> 
<p>7. SOCCER The dimensions of a field for Men's and Women's NCAA soccer can be no more than 80 yards by 120 yards. If the field has those dimensions what is the perimeter of the field?</p>	<p>8. FENCING Mr. Lao is planning to build a rectangular cattle pen that measures 50 feet by 75 feet. Find the total length of fencing that he will need to purchase.</p>

8-5 Practice: Problem Solving

Area

1. FLOOR PLANS Matt's bedroom is shaped like a parallelogram. His parents have decided to buy a new carpet for his room. If two opposite walls are 12 feet long and the distance between these walls is 8 feet, how many square feet of carpet will they need to buy?

2. GLASS COSTS Mrs. Humphrey needs to replace a broken window at her house. The window is shaped like a trapezoid with the dimensions shown below. If glass costs \$4.50 per square foot, how much will the replacement window cost?

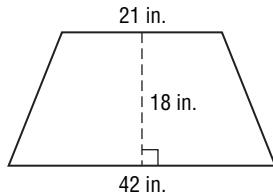

3. Melanie wants to cut her cake into triangular wedges to serve at her party. She cannot decide what kind of triangle to cut. She tries two possible triangular wedges.

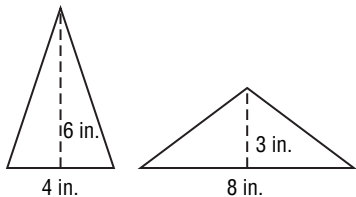

Piece 1

Piece 2

What is the area of the first wedge?
 What is the area of the second wedge?

4. DRUMS What is the area of the drumhead on the drum shown below? Round to the nearest tenth.

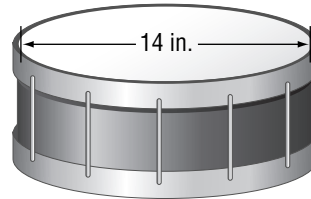

5. GARDENING Jane needs to buy mulch for the garden with the dimensions shown in the figure. For how much area does Jane need to buy mulch? Round to the nearest tenth.

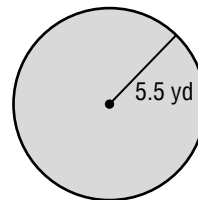

6. UTILITIES What is the area of the top surface of a circular manhole cover that has a radius of 30 centimeters? Round to the nearest tenth.

8-6

Practice: Problem Solving

Problem-Solving Strategy: Make a Model

Solve each problem using any strategy you have learned.

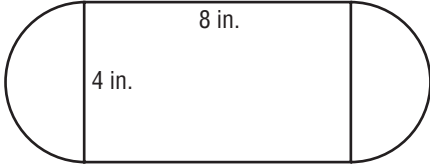
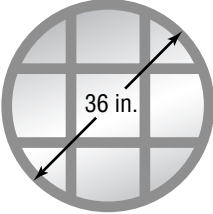
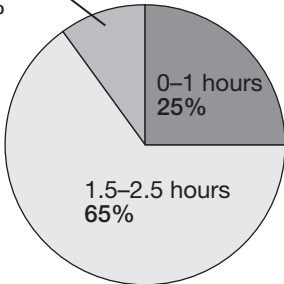
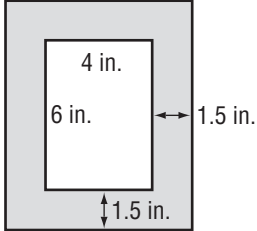
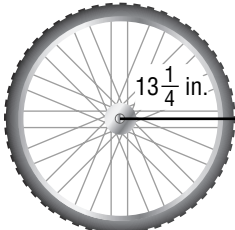
<p>1. AREA Find the area of the figure below. Use 3.14 for π.</p> 	<p>2. FOUNTAINS The circular fountain in front of the courthouse has a radius of 9.4 feet. What is the circumference of the fountain? Round to the nearest tenth.</p>
<p>3. WINDOWS Find the area of the window shown below. Round to the nearest tenth.</p> 	<p>4. SCALE DRAWING Shannon is creating a scale drawing of her classroom. If she is using the scale 1 foot = $\frac{1}{2}$ inch and the room model is 10 inches by 15 inches, what are the dimensions of the actual room?</p>
<p>5. STUDY TIME The circle graph below shows the results to a survey asking students how long they study each night. In a school of 400 students, how many students study 1.5 – 2.5 hours per night?</p> 	<p>6. PHOTOGRAPHY What is the area of the mat pictured below?</p> 
<p>7. BICYCLES A bicycle tire has a radius of $13\frac{1}{4}$ inches. How far will the bicycle travel in 40 rotations of the tire? Round to the nearest tenth.</p> 	<p>8. LANDSCAPING Joni has a circular garden with a diameter of $14\frac{1}{2}$ feet. If she uses 2 teaspoons of fertilizer for every 25 square feet of garden, how much fertilizer will Joni need for her entire garden? Round to the nearest tenth.</p>

Copyright © Glencoe/McGraw-Hill, a division of The McGraw-Hill Companies, Inc.

8-7 Practice: Problem Solving

Solid Figures and Volume

1. CAMPING A tent used for camping is shown below. Find the volume of the tent.

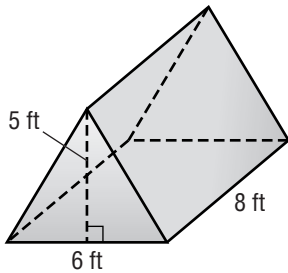

2. SOUVENIRS On a trip to Egypt, Myra bought a small glass pyramid as a souvenir. Find the volume of the glass used to make the pyramid. Round to the nearest tenth.

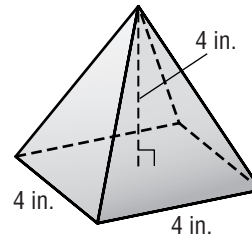

3. ART An artist created a commemorative marker in the shape of a cylinder. Find the volume of the stone used to make the marker. Round to the nearest tenth.

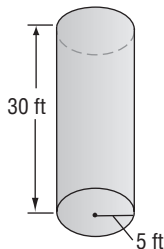

4. DONATIONS Lawrence is donating some outgrown clothes to charity. The dimensions of the box he is using are shown below. How many cubic feet of clothes will fit in the box?

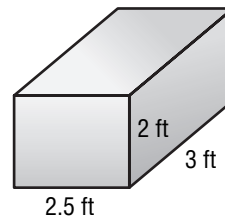

5. FARM LIFE A trough used for watering horses is shown in the figure. The trough is half of a cylinder. How many cubic feet of water will the trough hold? Round to the nearest tenth.

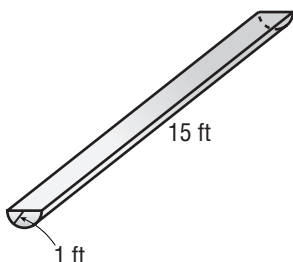

6. FARM LIFE If the volume of the water in the trough in Exercise 5 decreases by 5.6 ft^3 per day, after how many days will the trough be empty? Round to the nearest tenth if necessary.

8-8

Practice: Problem Solving

Surface Area

- DECORATING** Ms. Frank is going to wallpaper a living room with dimensions 24 feet long, 18 feet wide, and 8 feet high. What surface area does Ms. Frank plan to wallpaper?
- MANUFACTURING** The Acme Canning Company produces cans for chicken soup. If each can has a diameter of 2 inches and a height of $3\frac{1}{4}$ inches, how much aluminum is needed to make one can? Round to the nearest hundredth.
- MUSEUM** A museum curator needs to order a display case for a small artifact. The case needs to be a rectangular prism and made entirely of clear plastic. The bases must each measure $1\frac{1}{2}$ feet by $1\frac{3}{4}$ feet and the sides each 3 feet high. Find the cost of the case if the clear plastic costs \$10 per square foot.
- SIDING** The Ramirez family is going to put vinyl siding on a shed. They will cover all four walls completely, except for the door. The siding costs \$3 per square foot. How much will the siding cost for their shed?

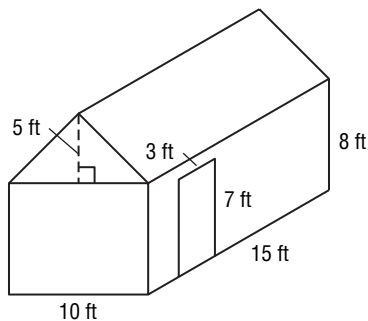

SHIPPING For Exercises 5–7, use the following information.

FPS, a shipping company, uses a container in the shape of a triangular prism to pack blueprints, posters, and other items that can be rolled up to fit inside the container. Packages-R-Us uses a container shaped like a cylinder for the same purposes. The cardboard used to make each container costs the same amount per square inch.

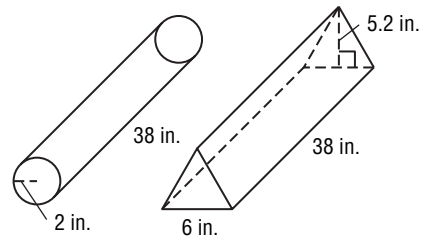

- What is the surface area of the FPS box?
- What is the surface area of the Packages-R-US box?
- If each company buys 100 of these packages, which company will spend less money per package? Explain.
- STORAGE TANKS** A water storage tank has a roof that is shaped like a square pyramid. What is the surface area of the water tank?

