

**1-1 Enrichment**

6MRI.1, 5NS2.1

***The Great State Mystery***

The United States of America has not always had 50 states. The states gradually joined the Union, starting with the first state in 1787 to the most recent state in 1959. The tables lists 15 states and their populations based on the 2000 Census. Use the 6 clues given and a problem solving process to complete the table below.

<b>Delaware</b>	783,600	<b>Iowa</b>	2,926,324	<b>New York</b>	18,976,457
<b>Georgia</b>	8,186,453	<b>Louisiana</b>	4,468,976	<b>Ohio</b>	11,353,140
<b>Hawaii</b>	1,211,537	<b>Mississippi</b>	2,844,658	<b>Texas</b>	20,851,820
<b>Illinois</b>	12,419,293	<b>New Jersey</b>	8,414,350	<b>Wisconsin</b>	5,363,675
<b>Indiana</b>	6,080,485	<b>New Mexico</b>	1,819,046	<b>Virginia</b>	7,078,515

1. The first state to enter the Union has the least population of the states listed.
2. The states beginning with the letter 'I' were the 19th, 21st, and 29th states admitted to the Union. Iowa entered the Union 30 years after Indiana.
3. New Jersey and Georgia were among the original thirteen colonies. Their entry number is the same as the digit in the hundreds place of their population.
4. Hawaii, Texas, and Wisconsin were the 28th, 30th, and 50th states admitted to the Union, but not in that order. To find their order, put them in order from greatest to least population.
5. The state with the second largest population entered the Union 15 years before Ohio and 24 years before the state with a population in the 4 millions.
6. The day of the month that Mississippi was admitted into the Union can be found by dividing its order of entry by 2.

Order of Entry	State Name	Date of Entry
1		December 7, 1787
3		December 18, 1787
4		January 2, 1788
10		June 25, 1788
11		June 26, 1788
17	Ohio	March 1,
18		April 30, 1812
	Indiana	December 11, 1816
20	Mississippi	December , 1817
21		December 3, 1818
		December 29, 1845
29		December 28, 1846
		May 29, 1848
47	New Mexico	January 6, 1912
		August 21, 1959

**1-2****Enrichment****6AF1.3*****The Four-Digit Problem***

Use the digits 1, 2, 3, and 4 to write expressions for the numbers 1 through 50. Each digit is used exactly once in each expression. (There might be more than one expression for a given number.)

You can use addition, subtraction, multiplication (not division), exponents, and parentheses in any way you wish. Also, you can use two digits to make one number, as in 34. A few expressions are given to get you started.

$1 = (3 \times 1) - (4 - 2)$

$18 =$

$35 = 2^{(4 + 1)} + 3$

$2 =$

$19 = 3(2 + 4) + 1$

$36 =$

$3 =$

$20 =$

$37 =$

$4 =$

$21 =$

$38 =$

$5 =$

$22 =$

$39 =$

$6 =$

$23 = 31 - (4 \times 2)$

$40 =$

$7 =$

$24 =$

$41 =$

$8 =$

$25 =$

$42 =$

$9 =$

$26 =$

$43 = 42 + 1^3$

$10 =$

$27 =$

$44 =$

$11 =$

$28 =$

$45 =$

$12 =$

$29 = 2^{(4 + 1)} - 3$

$46 =$

$13 =$

$30 =$

$47 =$

$14 =$

$31 =$

$48 =$

$15 = 2(3 + 4) + 1$

$32 =$

$49 =$

$16 =$

$33 =$

$50 =$

$17 =$

$34 =$

## The Geometric Mean

The square root of the product of two numbers is called their **geometric mean**.

The geometric mean of 12 and 48 is  $\sqrt{12 \cdot 48} = \sqrt{576}$  or 24.

**Find the geometric mean for each pair of numbers.**

1. 2 and 8

2. 4 and 9

3. 9 and 16

4. 16 and 4

5. 16 and 36

6. 12 and 3

7. 18 and 8

8. 2 and 18

9. 27 and 12

Recall the definition of a **geometric sequence**. Each term is found by multiplying the previous term by the same number. A missing term in a geometric sequence equals the geometric mean of the two terms on either side.

**Find the missing term in each geometric sequence.**

10. 4, 12, , 108, 324

11. 10, , 62.5, 156.25, 390.625

12. 1, 0.4, , 0.064, 0.0256

13. 700, 70, 7, 0.7, , 0.007

14. 6, , 24

15. 18, , 32

**1-4****Enrichment****6AF1.3, 6AF1.4*****Nested Expressions*****Nested Expressions**

Sometimes more than one set of parentheses are used to group the quantities in an expression. These expressions are said to have “nested” parentheses. The expression below has “nested” parentheses.

$$(4 + (3 \cdot (2 + 3)) + 8) \div 9$$

Expressions with several sets of grouping symbols are clearer if braces such as { } or brackets such as [ ] are used. Here is the same example written with brackets and braces.

$$\{4 + [3 \cdot (2 + 3)] + 8\} \div 9$$

To evaluate expressions of this type, work from the inside out.

$$\begin{aligned} \{4 + [3 \cdot (2 + 3)] + 8\} \div 9 &= \{4 + [3 \cdot 5] + 8\} \div 9 \\ &= [4 + 15 + 8] \div 9 \\ &= 27 \div 9 \\ &= 3 \end{aligned}$$

**Evaluate each expression.**

1.  $3 + [(24 \div 8) \cdot 7] - 20$

2.  $[(16 - 7 + 5) \div 2] - 7$

3.  $[2 \cdot (23 - 6) + 14] \div 6$

4.  $50 - [3 \cdot (15 - 5)] + 25$

5.  $12 + \{28 - [2 \cdot (11 - 7)] + 3\}$

6.  $\{75 + 3 \cdot [(17 - 9) \div 2]\} \cdot 2$

7.  $20 + \{3 \cdot [6 + (56 \div 8)]\}$

8.  $\{4 + [5 \cdot (12 - 5)] + 15\} \cdot 10$

9.  $\{15 \cdot [(38 - 26) \div 4]\} - 15$

10.  $\{[34 + (6 \cdot 5)] \div 8\} + 40$

## The First Lady of Science

Chinese-American physicist Chien-Shiung Wu (1912–1997) was born in Shanghai, China. At the age of 24, she came to the United States to further her studies in science. She received her doctorate in physics from the University of California, Berkeley in 1940. Dr. Wu became the first female professor at Princeton University and worked on the Manhattan Project during World War II.

Dr. Wu paved the way for many female scientists. She received numerous awards and honors from American and Chinese universities and was the first woman president of the American Physical Society. She was also the first living scientist to have an asteroid named in her honor.

**Evaluate each expression for  $p = 9$ ,  $q = 5$ ,  $r = 7$ , and  $x = 8$ .  
The problem letter and the solution form a key to decoding  
another fact about Dr. Wu shown below.**

**A.**  $r + 3$

**C.**  $10q$

**E.**  $q + r$

**G.**  $p + 5$

**H.**  $6r - x$

**N.**  $6 + 4x$

**O.**  $3q + 5p$

**P.**  $70 - 2p$

**R.**  $r^2 + 5$

**S.**  $4q^2 - 3$

**T.**  $2r^2$

**Y.**  $8r - 5$

**In Chinese, *Chien-Shiung* means...**

97   98   54   60   38   97   34   12   54   60

**1-7 Enrichment**

6AF1.1

**Equations as Models****Equations as Models**

When you write an equation that represents the information in a problem, the equation serves as a model for the problem. One equation can be a model for several different problems.

Each of Exercises 1–8 can be modeled by one of these equations.

$$n + 2 = 10 \quad n - 2 = 10 \quad 2n = 10 \quad \frac{n}{2} = 10$$

Choose the correct equation. Then solve the problem.

- Chum earned \$10 for working two hours. How much did he earn per hour?
- Ana needs \$2 more to buy a \$10 scarf. How much money does she already have?
- Kathy and her brother won a contest and shared the prize equally. Each received \$10. What was the amount of the prize?
- Jameel loaned two tapes to a friend. He has ten tapes left. How many tapes did Jameel originally have?
- In the figure below, the length of  $\overline{AC}$  is 10 cm. The length of  $\overline{BC}$  is 2 cm. What is the length of  $\overline{AB}$ ?
- Ray  $\overline{AC}$  bisects  $\angle BAD$ . The measure of  $\angle BAC$  is  $10^\circ$ . What is the measure of  $\angle BAD$ ?

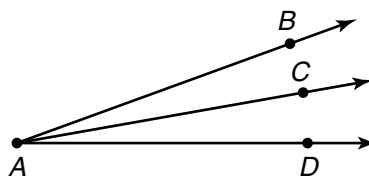
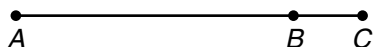

- The width of the rectangle below is 2 inches less than the length. What is the length?

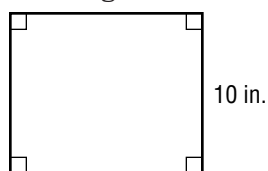

- In the triangle below, the length of  $\overline{PQ}$  is twice the length of  $\overline{QR}$ . What is the length of  $\overline{QR}$ ?

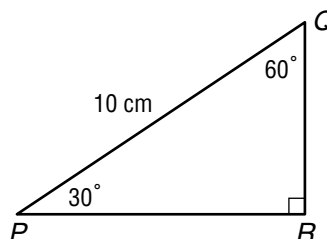

- CHALLENGE** On a separate sheet of paper, write a problem that can be modeled by the equation  $3a + 5 = 29$ .

**1-8 Enrichment**

6AF1.3

**Name That Property****Name That Property**

You know that the Commutative Property applies to the operations of addition and multiplication. You also know that the Associative Property applies to operations of addition and multiplication. What about the other operations? Does the Commutative Property apply to division? Does the Associative Property apply to subtraction? Does the Distributive Property apply to subtraction or division?

Look at these examples to determine if the properties also apply to subtraction or division.

**Commutative Property****Subtraction***Try this:*

$$5 - 4 \stackrel{?}{=} 4 - 5$$

**Division***Try this:*

$$8 \div 2 \stackrel{?}{=} 2 \div 8$$

1. Does the Commutative Property apply to division and subtraction? Explain.

**Associative Property****Subtraction***Try this:*

$$7 - (3 - 2) \stackrel{?}{=} (7 - 3) - 2$$

**Division***Try this:*

$$8 \div (4 \div 2) \stackrel{?}{=} (8 \div 4) \div 2$$

2. Does the Associative Property apply to subtraction and division? Explain.

**Distributive Property****Subtraction***Try this:*

$$\begin{aligned} 3(8 - 2) &\stackrel{?}{=} 3 \times 8 - 3 \times 2 \\ 3(6) &\stackrel{?}{=} 24 - 6 \\ 18 &= 18 \checkmark \end{aligned}$$

**Division***Try this:*

$$\begin{aligned} 3(8 \div 2) &\stackrel{?}{=} 3 \times 8 \div 3 \times 2 \\ 3(4) &\stackrel{?}{=} 24 \div 6 \\ 12 &\neq 4 \end{aligned}$$

3. Does the Distributive Property apply to multiplication over subtraction? Does it apply to multiplication over division? Explain.

**Other Sequences**

When each term in a sequence decreases, it is described as a *declining sequence*. Either subtracting the same number from the previous term or dividing the previous term by the same number creates a declining sequence.

$$\begin{array}{ccccccc} 81, & 27, & 9, & 3, & \dots & & \\ \downarrow & \downarrow & \downarrow & & & & \\ \div 3 & \div 3 & \div 3 & & & & \end{array}$$

In this sequence, each term is found by dividing the previous term by 3.

Some sequences are formed by using two operations.

$$\begin{array}{ccccccc} 2, & 5, & 11, & 23, & 47, & \dots & \\ \downarrow & \downarrow & \downarrow & \downarrow & & & \\ \times 2+1 & \times 2+1 & \times 2+1 & \times 2+1 & & & \end{array}$$

In this sequence, each term is found by multiplying the previous term by 2 and then adding 1.

**Describe the rule in each sequence. Then write the next three terms.**

1. 40, 38, 36, 34, ...

2. 128, 64, 32, 16, ...

3. 7.5, 6.4, 5.3, 4.2, ...

4. 1, 4, 13, 40, ...

5. 1, 5, 13, 61, ... Multiply by 2 and

6. 1, 5, 21, 85, ... Multiply by 4 and

**Create a five-term sequence using the rule stated. Start with the given number.**

7. Subtract 8 from each term; 78.

8. Divide each term by 10; 80.

9. Subtract 11 from each term; 132.

10. Multiply each term by 10 and subtract 9; 4.

11. Multiply each term by 7 and add 2; 1.

12. Multiply each term by 3 and subtract 2; 6.

**CHALLENGE** For Exercises 13–15, use the sequence 589, 5,889, 58,889, 588,889, ...

13. Describe the rule of the sequence.

14. Study the pattern in the sequence. Without extending the sequence, what is the sixth term of the sequence? What is the tenth term?

15. Describe how you can find any term of the sequence.



# 1-10 Enrichment

6AF1.2, 6MR2.4

To solve equations containing two variables, find ordered pair solutions for the equation by selecting values for  $x$  and completing a table. Although any value can be selected for  $x$ , values usually selected include  $-2, -1, 0, 1,$  and  $2$ .

For example, to solve the equation  $y = 2x$  given below in Exercise 1, first select values for  $x$ , then complete a table.

Ordered pair solutions for the equation  $y = 2x$  include  $(-2, -4), (-1, -2), (0, 0), (1, 2),$  and  $(2, 4)$ .

Match each equation with the point whose coordinates are a solution of the equation. Then, at the bottom of the page, write the letter of the point on the line directly above the number of the equation *each time it appears*. (The first one has been done as an example.) If you have matched the equations and solutions correctly, the letters below will reveal a message.

- |                       |           |           |
|-----------------------|-----------|-----------|
| 1. $y = 2x$           | A(-3, 8)  | N(-1, 0)  |
| 2. $y = x - 3$        | B(0, 2)   | O(3, 0)   |
| 3. $y = -x + 1$       | C(-2, 1)  | P(1, 5)   |
| 4. $y = 3x - 2$       | D(0, -5)  | Q(0, 6)   |
| 5. $y = -2x - 4$      | E(-1, -5) | R(1, 6)   |
| 6. $y = x + (-2)$     | F(1, 3)   | S(2, 1)   |
| 7. $y = -4x - 1$      | G(0, -4)  | T(-2, 3)  |
| 8. $y = \frac{1}{2}x$ | H(-1, 3)  | U(1, 2)   |
| 9. $y = x + 3$        | I(2, 0)   | V(-3, 5)  |
| 10. $y = 7x + 7$      | J(0, 4)   | W(0, -7)  |
| 11. $y = -2x - 6$     | K(-3, 1)  | X(-3, -3) |
| 12. $y = -x + 5$      | L(-4, 2)  | Y(1, 8)   |
| 13. $y = -5x + 8$     | M(-2, 2)  | Z(0, -8)  |
| 14. $y = -x$          |           |           |

14	12	3	7	4	14	12	3	6	9	8	6	8	3	7	4	
<b>U</b>																
11	12	10	5	1	12	5	4	2	13	8	9	6	4	10	9	4

**2-1****Enrichment**

6NS1.1

**Jaime Escalante**

Jaime Escalante (1930– ) was born in La Paz, Bolivia, and came to the United States in 1963. For ten years, he worked at odd jobs to support himself and his family while pursuing his dream—becoming certified to teach high school mathematics in California. As a mathematics teacher, he has become well known for his ability to inspire students to succeed in mathematics at levels they never thought possible. In 1988, the story of Mr. Escalante and a group of his students was the subject of the popular motion picture *Stand and Deliver*.

Mr. Escalante teaches concepts students must master if they are to succeed in high school and college mathematics. One of these is the concept of absolute value. For instance, a student should be able to solve an equation like  $|y| = 6$  quickly using mental math. Here's how.

You know that  $|6| = 6$  and  $|-6| = 6$ .

So, the equation  $|y| = 6$  has *two* solutions: 6 and  $-6$ .

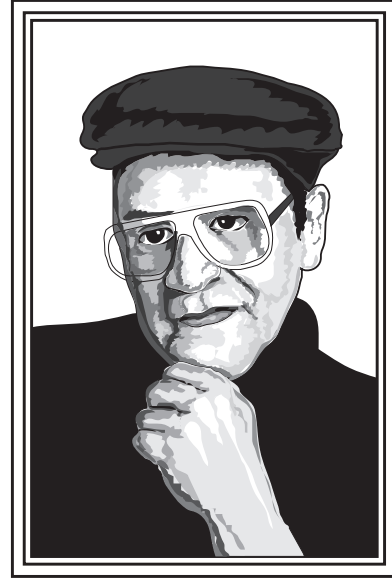

**Solve each equation. (Hint: One equation has no solution.)**

1.  $|a| = 8$

2.  $|r| = 0$

3.  $|j| = -3$

4.  $|t| + 1 = 15$

5.  $10 - |m| = 3$

6.  $|c| - 4 = 16$

7.  $5|z| = 60$

8.  $12 \div |g| = 4$

9.  $48 = 8|x|$

10.  $2|d| + 3 = 5$

11.  $4|p| - 9 = 59$

12.  $7|z| + 12 = 12$

13. Suppose that the value of  $x$  can be selected from the set  $\{-2, -1, 0, 1, 2\}$ . Find all of the solutions of the equation  $|x| = x$ .

14. One of these statements is false. Which one is it? Explain.

- The absolute value of every integer is positive.
- There is at least one integer whose absolute value is zero.
- The absolute value of an integer is never negative.

**Quantitative Comparisons**

An unusual type of problem is found on some standardized multiple-choice tests. This problem type is called the *quantitative comparison*.

In each quantitative comparison question, you are given two quantities, one in Column A and one in Column B. You are to compare the two quantities and shade one of four circles on an answer sheet.

- Shade circle A if the quantity in Column A is greater;  
 Shade circle B if the quantity in Column B is greater;  
 Shade circle C if the two quantities are equal;  
 Shade circle D if the relationship cannot be determined from the information given.

**Shade the correct oval to the left of each problem number.**

	Column A	Column B
(A) (B) (C) (D) 1.	$0.006 + 2$	$0.002 + 6$
(A) (B) (C) (D) 2.	ten billion dollars	1,000 million dollars
(A) (B) (C) (D) 3.	20 inches	the perimeter of a square with an area of 25 square inches
(A) (B) (C) (D) 4.	half of one third	one fifth
(A) (B) (C) (D) 5.	the greatest possible product of two odd positive numbers less than 20	the greatest possible product of two even positive numbers less than 20
(A) (B) (C) (D) 6.	0.000000001	$-x$ if $x$ is greater than 0
(A) (B) (C) (D) 7.	$ x $	$ x + 1 $
(A) (B) (C) (D) 8.	$ y $	$ -y $
(A) (B) (C) (D) 9.	$2 x $ if $x \neq 0$	$ x $ if $x \neq 0$
(A) (B) (C) (D) 10.	$-x$ if $x$ is less than 0	$ x $ if $x$ is less than 0

# 2-3

## Enrichment

5AF1., 6MR2.4

### Relic Hunter

The game of Relic Hunter is based on methods used to record the precise locations of artifacts discovered at archaeological digs. Archaeologists use string to position a grid over a dig site. An artifact's location is named by the row and column in the grid.

Relic Hunter is played with two players who each secretly place six artifacts on one of the coordinate grids below. Artifacts may not overlap. Each player should not be able to see where the other player's artifacts are hidden. A player must look for the artifacts by guessing an ordered pair. The other player then finds that location on the secret grid and tells the first player whether part of the artifact is located in that section and what the artifact is. Each player's empty coordinate grid should be used to mark the locations of guesses and of found artifacts. The winner is the player who first uncovers all of the opponent's artifacts.

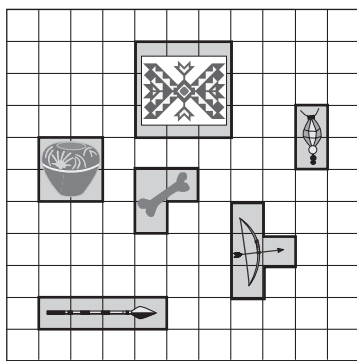

5											
4											
3											
2											
1											
0											
-1											
-2											
-3											
-4											
-5											
	-5	-4	-3	-2	-1	0	1	2	3	4	5

5											
4											
3											
2											
1											
0											
-1											
-2											
-3											
-4											
-5											
	-5	-4	-3	-2	-1	0	1	2	3	4	5

**For Exercises 1–6, list each ordered pair that could contain the rest of the artifact. Then play the game with a partner. Use one coordinate grid to keep track of the points where you hide your artifacts and another coordinate grid to keep track of the points you have guessed.**

- You uncover parts of the spear at points  $(-2, 3)$  and  $(-2, 4)$ .
- You uncover part of the animal bone at points  $(2, 1)$  and  $(2, 2)$ .
- You uncover a part of the amulet at point  $(-4, -2)$ .
- You uncover a part of the clay pot at point  $(0, -1)$ .
- You uncover a part of the bow at point  $(5, -5)$ .
- Part of the amulet is located at point  $(-5, -2)$ , and there is nothing at point  $(-2, -4)$ . You uncover a part of the mosaic panel at point  $(-4, -4)$ . What other points could contain the mosaic panel?

**2-4**

**Enrichment**

**6NS2.3**

**Adding a List of Integers**

When you need to add a list of integers, sometimes it can be helpful to reorder the list of integers so you first add all the positive integers, and then all the negative integers.

**Example**

Marcy is studying weather conditions for her science fair project. During one 24-hour period, she recorded the changes in air temperature in the table at right. If the air temperature was 76°F at the start of her observations, what was the air temperature 24 hours later?

Time	Change in Temp. (°F)	Time	Change in Temp. (°F)
02:00	-1	14:00	-16
04:00	-2	16:00	+2
06:00	+2	18:00	+1
08:00	+4	20:00	+3
10:00	+4	22:00	-1
12:00	+3	00:00	-2

First add all the positive changes in air temperature and then all the negative changes in air temperature.

$$(+2) + (+4) + (+4) + (+3) + (+2) + (+1) + (+3) = +19$$

$$(-1) + (-2) + (-16) + (-1) + (-2) = -22$$

Next add the results to find the overall change and the new temperature.

$$+19 + (-22) = -3$$

$$76^\circ + (-3^\circ) = 73^\circ\text{F}$$

**Exercises**

- The passenger elevator in the Empire State Building registered the following journey log between 9:00 A.M. and 9:15 A.M. on a Monday morning. At which floor was the elevator at 9:15 A.M. if it started in the Lobby, which is Floor 1?

Number of floors	↑ 17	↑ 21	↓ 16	↓ 3	↓ 4	↑ 11	↓ 19
------------------	------	------	------	-----	-----	------	------

- A deep-sea diver attached to a safety cable was lowered into the water to a depth of 600 feet. During the next hour, the safety cable was let out 250 feet, pulled in 36 feet, pulled in 69 feet, let out 23 feet, pulled in 51 feet, let out 68 feet, and pulled in 24 feet to allow the diver to explore. At the end of the hour, what was the depth of the diver?

- The Franklin Wildcats football team was competing in the regional championship game. The offense had the ball at the 50-yard line as they tried to score to win the game. Their progress during each play was as follows.

gain 7, gain 2, lose 1, gain 4, lose 5, gain 27, gain 4, gain 5, gain 0, gain 3, lose 2, lose 1, gain 1, gain 2

On what yard line did the Wildcats end?

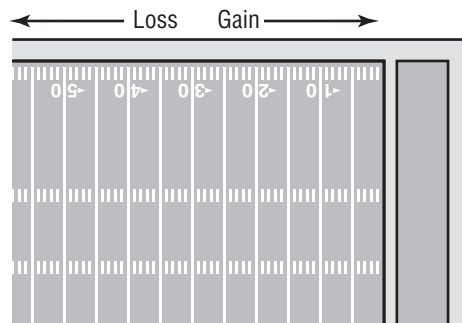

**2-5****Enrichment**

6NS2.3

**Distance on the Number Line**

To find the distance between two points on a number line, subtract their coordinates. Then, take the absolute value of the difference.

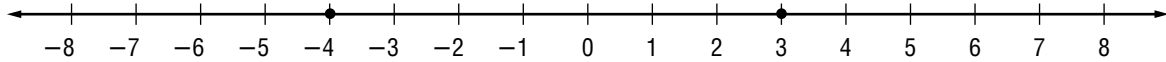

$$-4 - 3 = -7$$

$$|-7| = 7$$

You can also find the distance by finding the absolute value of the difference of the coordinates.

$$|-4 - 3| = 7$$

**Graph each pair of points. Then write an expression using absolute value to find the distance between the points.**

1.  $A$  at  $-5$  and  $B$  at  $2$

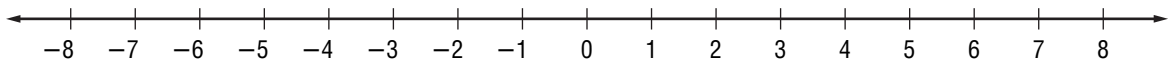

2.  $C$  at  $-7$  and  $D$  at  $-1$

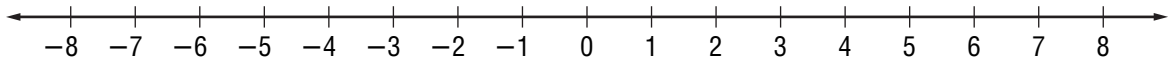

3.  $E$  at  $-5$  and  $F$  at  $5$

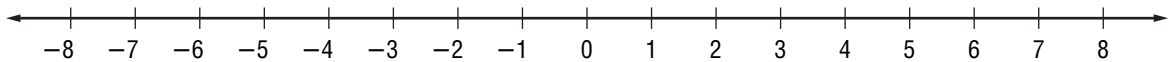

4.  $W$  at  $0$  and  $X$  at  $6$

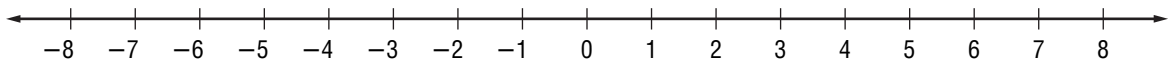

5.  $Y$  at  $-4$  and  $Z$  at  $0$

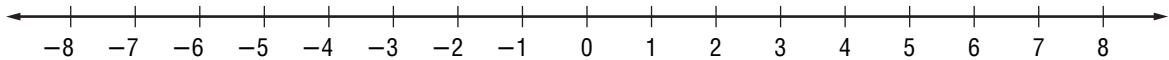

**2-6**

**Enrichment**

6NS2.3

**Integer Maze**

Find your way through the maze by moving to the expression in an adjacent section with the next highest value.

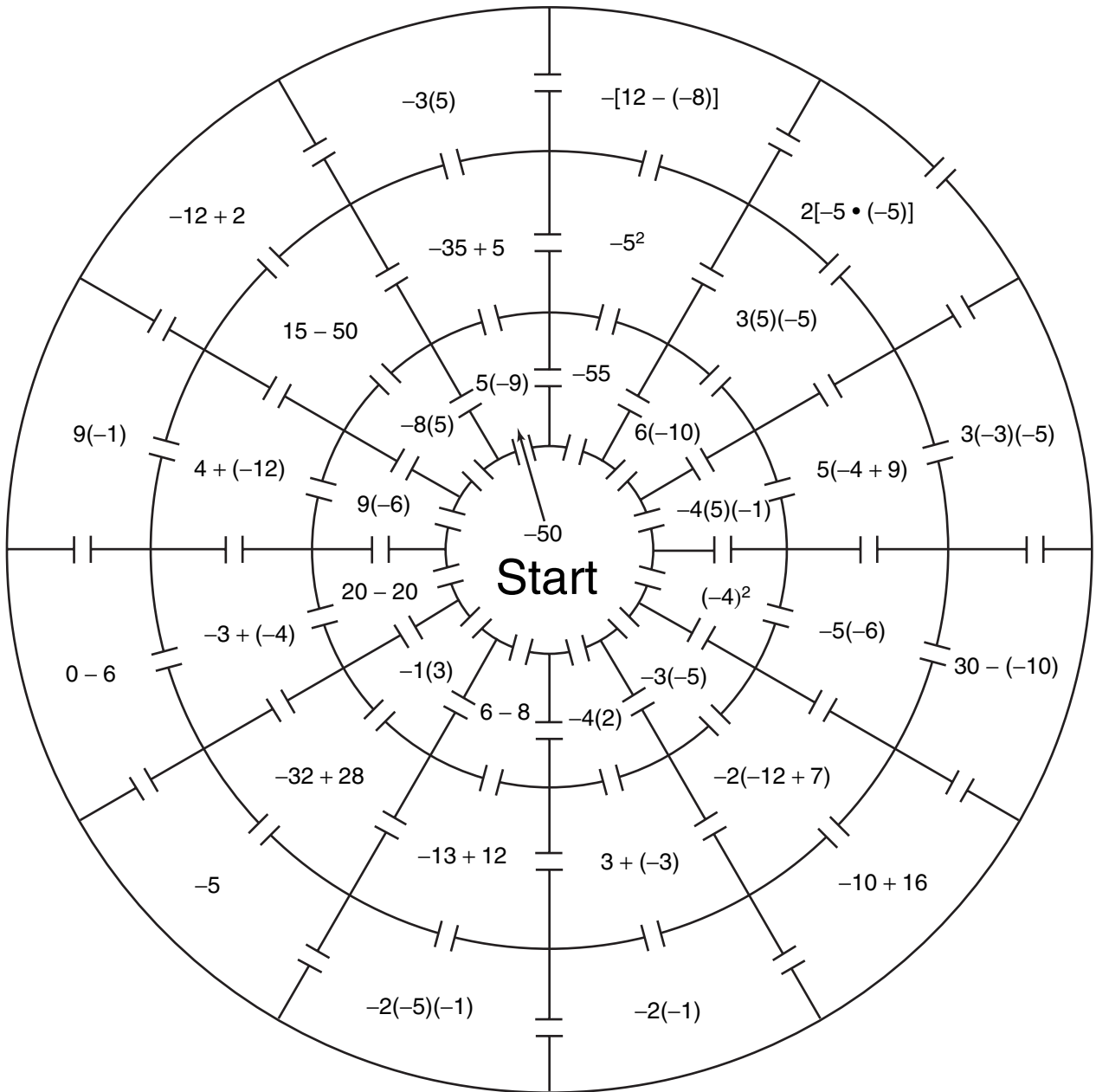

Copyright © Glencoe/McGraw-Hill, a division of The McGraw-Hill Companies, Inc.

Lesson 2-6

## Division by Zero?

Some interesting things happen when you try to divide by zero. For example, look at these two equations.

$$\frac{5}{0} = x \qquad \frac{0}{0} = y$$

If you can write the equations above, you can also write the two equations below.

$$0 \cdot x = 5 \qquad 0 \cdot y = 0$$

However, there is no number that will make the left equation true. This equation has no solution. For the right equation, *every* number will make it true. The solutions for this equation are “all numbers.”

Because division by zero leads to impossible situations, it is not a “legal” step in solving a problem. People say that division by zero is undefined, or not possible, or simply not allowed.

**Describe the solution set for each equation.**

1.  $4x = 0$

2.  $x \cdot 0 = 0$

3.  $x \cdot 0 = x$

4.  $\frac{0}{x} = 0$

5.  $\frac{0}{x} = x$

6.  $\frac{0}{x} = 5$

**What values for  $x$  must be excluded to prevent division by 0?**

7.  $\frac{1}{x^2}$

8.  $\frac{1}{x - 1}$

9.  $\frac{1}{x + 1}$

10.  $\frac{0}{2x}$

11.  $\frac{1}{2x - 2}$

12.  $\frac{1}{3x + 6}$

**Explain what is wrong with this “proof.”**

13. Step 1  $0 \cdot 1 = 0$  and  $0 \cdot (-1) = 0$

Step 2 Therefore,  $\frac{0}{0} = 1$  and  $\frac{0}{0} = -1$ .

Step 3 Therefore,  $1 = -1$ .



**3-1**

**Enrichment**

6AF1.2

**Expressions for Figurate Numbers**

Figurate numbers are numbers that can be shown with dots arranged in specific geometric patterns. Below are the first five square numbers.

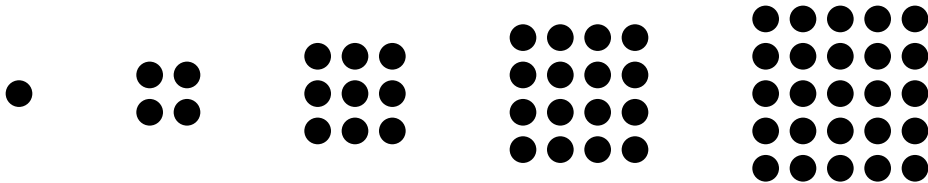

The expression  $n^2$  will give you the number of dots in the  $n$ th square number. The variable  $n$  takes on the values 1, 2, 3, 4, and so on. So, to find the 10th square number, you would use 10 for  $n$ .

- Match each set of dot patterns with its name and expression. Write exercise numbers in the boxes to show the matchings.

	Dot Patterns for Second and Third Numbers	Name of Figurate Number	Expression
a.		pentagonal <input type="checkbox"/>	$n(2n - 1)$ <input type="checkbox"/>
b.		hexagonal <input type="checkbox"/>	$\frac{n(n + 1)}{2}$ <input type="checkbox"/>
c.		triangular <input type="checkbox"/>	$\frac{n(3n - 1)}{2}$ <input type="checkbox"/>

Use the algebraic expressions on this page to compute each number. Then make a drawing of the number on a separate sheet of paper.

- 6th square
- 4th triangular
- 4th pentagonal
- 4th hexagonal
- 5th triangular
- 5th pentagonal

**3-2****Enrichment****6AF1.1, 6MR2.4****Equation Hexa-maze**

This figure is called a *hexa-maze* because each cell has the shape of a hexagon, or six-sided figure.

To solve the maze, start with the number in the center. This number is the solution to the equation in one of the adjacent cells. Move to that cell. The number in the new cell will then be the solution to the equation in the next cell. At each move, you may only move to an adjacent cell. Each cell is used only once.

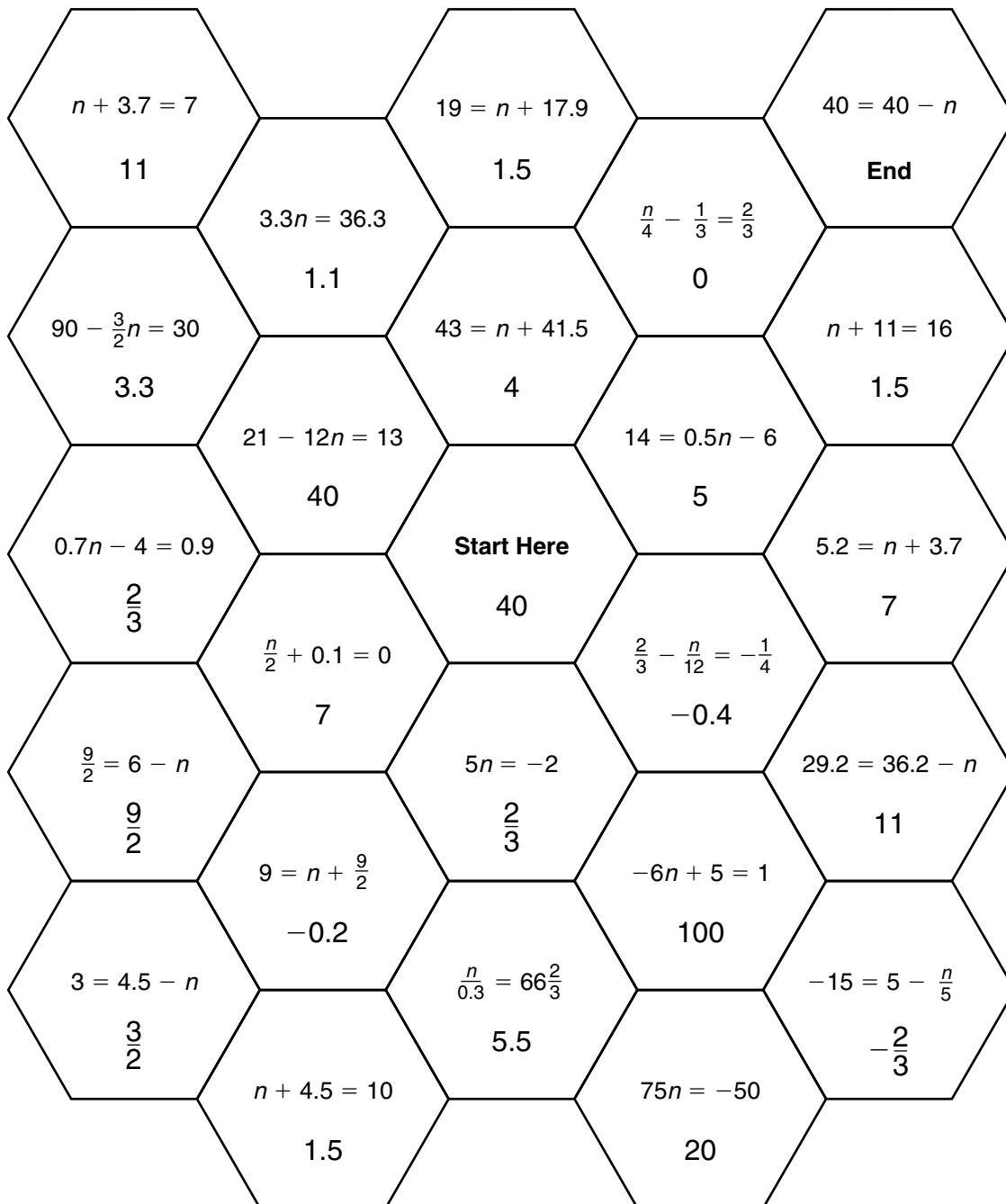

**3-3****Enrichment**

7AF1.1

***Direct Variation***

Equations of the form  $y = ax$  and  $y = x \div a$  can be used to show how one quantity varies with another. Here are two examples.

Driving at a speed of 50 miles per hour, the distance you travel  $d$  varies directly with the time you are on the road  $t$ . The longer you drive, the farther you get.

$$d = 50t$$

It is also the case that the time  $t$  varies directly with the distance  $d$ . The farther you drive, the more time it takes.

$$t = \frac{d}{50}$$

**Complete the equation for each situation. Then describe the relationship in words.**

1. If you go on a diet and lose 2 pounds a month, after a certain number of months  $m$ , you will have lost  $p$  pounds.
2. You and your family are deciding between two different places for your summer vacation. You plan to travel by car and estimate you will average 55 miles per hour. The distance traveled  $d$  will result in a travel time of  $t$  hours.
3. You find that you are spending more than you had planned on renting video movies. It costs \$2.00 to rent each movie. You can use the total amount spent  $a$  to find the number of movies you have rented  $m$ .
4. You spend \$30 a month to take the bus to school. After a certain number of months  $m$ , you will have spent a total of dollars  $d$  on transportation to school.
5. You are saving money for some new athletic equipment and have 12 weeks before the season starts. The amount you need to save each week  $s$  will depend on the cost  $c$  of the equipment you want to buy.

**3-5** **Enrichment**

7AF4.1

**Equations with Like Terms**

Some equations contain two or more expressions that are called *like terms*. For example, in the equation  $3a + 2a + 4 = 14$ , the expressions  $3a$  and  $2a$  are like terms. When you see like terms, you can combine them into one expression.

$$3a + 2a = 5a$$

When you solve an equation containing like terms, combine them first before continuing to solve the equation. To solve  $3a + 2a + 4 = 14$ , proceed as follows.

$$\begin{aligned} (3a + 2a) + 4 &= 14 \\ &\swarrow \qquad \searrow \\ &5a + 4 = 14 \\ 5a + 4 - 4 &= 14 - 4 \\ 5a &= 10 \\ \frac{5a}{5} &= \frac{10}{5} \\ a &= 2 \end{aligned} \quad \begin{array}{l} \textit{Combine like terms.} \end{array}$$

**Solve each equation. Then locate the solution on the number line below. Place the letter corresponding to the answer on the line at the right of the exercise.**

1.  $3x + 4x + 3 = -39$  \_\_\_\_\_

2.  $-3x - 2 + 5x = 12$  \_\_\_\_\_

3.  $-5 - 4x + 7x = 1$  \_\_\_\_\_

4.  $-\frac{1}{2}x + 6x - 2 = 20$  \_\_\_\_\_

5.  $-2.4x + 1.2 + 1.2x = 4.8$  \_\_\_\_\_

6.  $\frac{1}{3}(6 - x) = -1$  \_\_\_\_\_

7.  $1 = -\frac{1}{4}x + 5 + \frac{3}{4}x$  \_\_\_\_\_

8.  $7x + (-2x) + x = 42$  \_\_\_\_\_

9.  $\frac{2}{5}(5x + 5x) = -20$  \_\_\_\_\_

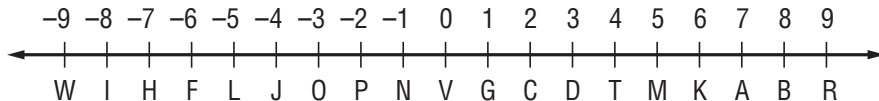

# 3-6 Enrichment

6AF3.1, 6AF3.2

## Perimeter and Area

Two shapes can have the same area and different perimeters. Each of these shapes has an area of 16 square units, but their perimeters are different.

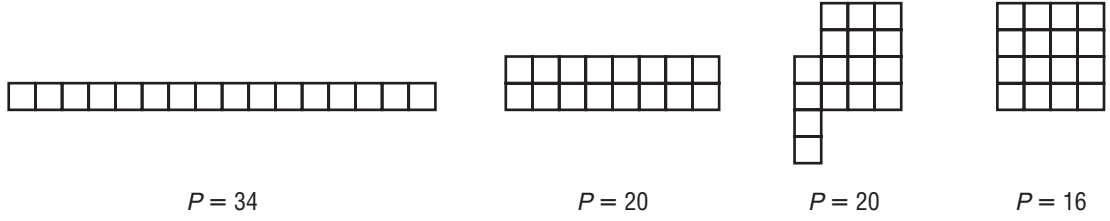

Among rectangles that have an area of 16 square feet, rectangles that are long and thin have the greatest perimeter. Rectangles with the least perimeter are more closely shaped to a square.

**The grid shows the basic floor plan of the Smith's house. The side of each grid represents 3 feet. The three bedrooms all have the same area.**

- Which of the rectangular bedrooms has the greatest perimeter? What is another dimension that will create a rectangle with the same area?
- Lisa's bedroom has an irregular shape. How does the area of her bedroom compare to the other two bedrooms? How does the perimeter of her bedroom compare to the other two bedrooms?

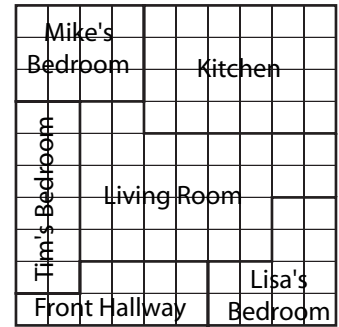

- The Smith's are moving to a new house. Design two different floor plans for them from which they may choose. Your floor plans must have five rooms including three bedrooms. Each bedroom must have an area of 162 square feet (18 squares) but not the same perimeters. You may add any other features to the house that you want.

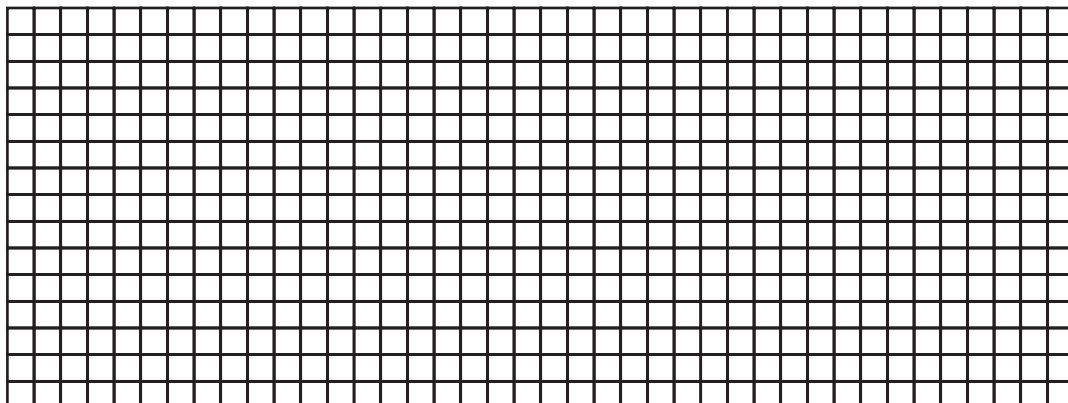

## Fundraising for Charity

Jacqui is leading a fund-raising group for a charity. The group is going to make buttons and sell them at a counter for \$6.00 each. Their goal is to raise \$1000. Jacqui creates a table to predict their earnings.

- Complete the table showing how much money will be raised based on the number of buttons sold.

Buttons Sold	Money Raised
10	
12	
14	
16	

- Make a line graph representing the functions from Jacqui's table.

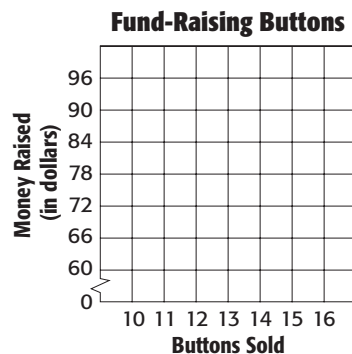

- At this rate, how many buttons does Jacqui's group need to sell to raise \$1000?
- Write an equation that relates the amount of money raised if there is a \$50 counter fee.
- If the group calculates in the \$50 counter fee, how many buttons do they need to sell in order to raise their goal of \$1000?

**4-1****Enrichment****6NS2.4****Perfect Numbers**

A positive integer is *perfect* if it equals the sum of its factors that are less than the integer itself.

If the sum of the factors (excluding the integer itself) is greater than the integer, the integer is called *abundant*.

If the sum of the factors (excluding the integer itself) is less than the integer, the integer is called *deficient*.

The factors of 28 (excluding 28 itself) are 1, 2, 4, 7, and 14.  
Since  $1 + 2 + 4 + 7 + 14 = 28$ , 28 is a perfect number.

**Complete the table to classify each number as perfect, abundant, or deficient.**

	Number	Divisors (Excluding the Number Itself)	Sum	Classification
1.	14			
2.	6			
3.	12			
4.	20			
5.	10			

**Show that each number is perfect.**

6. 496

7. 8,128

8. **CHALLENGE** 33,550,336

## Sundaram's Sieve

This arrangement of numbers is called Sundaram's Sieve. Like the Sieve of Eratosthenes, Sundaram's arrangement can be used to find prime numbers.

4	7	10	13	16	19	22	25	28	31
7	12	17	22	27	32	37	42	47	52
10	17	24	31	38	45	52	59	66	73
13	22	31	40	49	58	67	76	85	94
16	27	38	49	60	71	82	93	104	115

Here's how to use Sundaram's Sieve to find prime numbers. If a number,  $n$ , is not in the Sieve, then  $2n + 1$  is a prime number. If a number,  $n$ , is in the Sieve, then  $2n + 1$  is not a prime number.

32 is in the sieve.  $2 \times 32 + 1 = 65$  65 is not prime.

35 is not in the sieve.  $2 \times 35 + 1 = 71$  71 is prime.

- Does the sieve give all primes up to 99? all the composites?
- Sundaram's Sieve is constructed from arithmetic sequences. Describe the pattern used to make the first row.
- How is the first column constructed?
- How are the second through fifth rows constructed?
- How would you add a sixth row to the sieve?
- Use Sundaram's Sieve to find 5 four-digit prime numbers. You will need to add more numbers to the sieve to do this.



**4-4****Enrichment****6NS2.4****Parts of the World**

It can be difficult to understand comparisons of different continents and their populations because the numbers are so large. You can make these comparisons easier to understand by writing them as fractions and using rounding to find an estimated ratio.

Continent	Area (km <sup>2</sup> )	Population (2005 estimate)
Asia	44,529,000	3,879,000,000
Africa	30,065,000	877,500,000
North America	24,256,000	501,500,000
South America	17,819,000	379,500,000
Antarctica	13,209,000	0
Europe	9,938,000	727,000,000
Australia/Oceania	7,687,000	32,000,000
Total	147,503,000	6,396,500,000

Source: worldatlas.com

For example, the ratio of Asia's population to North America's population is

$\frac{501,500,000}{3,879,000,000}$  or  $\frac{5,015}{38,790}$ . If you divide both the numerator and denominator by 1,000, you get  $\frac{5.015}{38.79}$ , which can be approximated as  $\frac{5}{40}$  or about  $\frac{1}{8}$ .

1. Approximately what fraction of the world's land area is found in South America?
2. Approximately what fraction of the world's population is found in South America?
3. Approximately what fraction of Asia's land area does the North America fill? What percentage is this?
4. Which continent is more crowded, Asia or North America? Explain. *Hint:* Use the example at the top of the page and your answer to Exercise 4
5. Which continent has the largest population per square kilometer? Explain.

## Writing Repeating Decimals as Fractions

All fractions can be written as decimals that either terminate or repeat. You have learned how to use a power of 10 to write a terminating decimal as a fraction. Below, you will study a strategy to write a repeating decimal as a fraction.

**For Exercises 1–4, write each fraction as a decimal. Use bar notation if the decimal is a repeating decimal.**

1.  $\frac{1}{9}$

2.  $\frac{2}{9}$

3.  $\frac{3}{9}$

4.  $\frac{5}{9}$

5. Describe the relationship between the numerator of each fraction and its decimal equivalent.

**For Exercises 6–9, write each fraction as a decimal. Use bar notation if the decimal is a repeating decimal.**

6.  $\frac{7}{99}$

7.  $\frac{24}{99}$

8.  $\frac{37}{99}$

9.  $\frac{82}{99}$

10. Describe the relationship between the numerator of each fraction and its decimal equivalent.
11. Use the relationship from Exercise 10 to write the decimal  $0.\overline{52}$  as a fraction. Check your work using long division.
12. Using your observations from Exercises 5 and 11, make a prediction about the decimal equivalent of  $\frac{127}{999}$ . Check to see if your prediction was correct by using long division.
13. How are the decimal equivalents of  $\frac{4}{9}$ ,  $\frac{4}{99}$  and  $\frac{4}{999}$  different? Explain.

**For Exercises 14–19, write each decimal as a fraction. Check your answers with a calculator.**

14. 0.47474747...

15.  $0.\overline{22}$

16.  $0.\overline{530}$

17. 0.010010010...

18.  $0.\overline{3266}$

19.  $0.\overline{00328}$

## Margarita Colmenares

Margarita Colmenares is an environmental engineer. She is a native of Los Angeles and a 1981 graduate of Stanford University. In 1989, she became the first woman president of the Society of Hispanic Professional Engineers. Ms. Colmenares was recently appointed to direct an office at the U.S. Department of Education. She has a special interest in education and has traveled extensively to talk to student groups about careers in engineering.

Environmental engineers like Colmenares use mathematics to predict the effect that our actions will have on our environment. They may also recommend ways to protect the environment. On this page, you will consider some data and recommendations concerning water usage.

**Daily Water Usage in the United States (Per Person)**

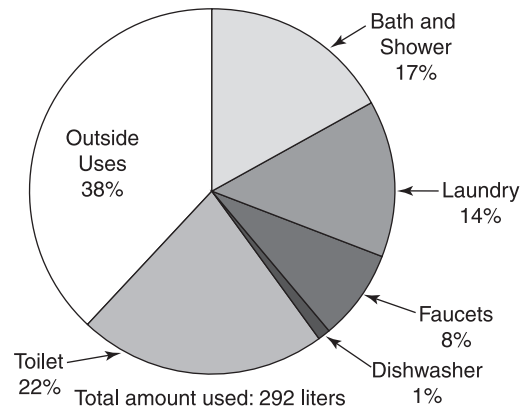

**Refer to the graph above.**

- Which one category accounts for more than  $\frac{1}{3}$  of the water usage?
- Estimate the fraction of a person's daily water usage that is for bath and shower.

**Use the graph above. Estimate the amount of water used in each category.**

- |                 |                    |
|-----------------|--------------------|
| 3. outside uses | 4. bath and shower |
| 5. toilet       | 6. laundry         |
| 7. dishwasher   | 8. faucets         |

**In each situation, what percent of the water used can be saved by following the recommendation?**

- Using a water-saving shower head can save 65 liters of water out of the 130 liters normally used in a five-minute shower.
- Turning off the water while brushing your teeth can reduce the water used from 20 liters to 2 liters.

## African-American Scientists and Inventors

When you buy a pair of shoes, you usually have a wide variety of styles, sizes, and prices to choose from. It is the work of an African-American inventor, Jan Matzeliger (1852–1889), that makes this possible. In 1882, Matzeliger patented a *lasting machine* that could shape the upper portion of a shoe and attach it to the sole in a fraction of the time it took to do the job by hand. Using this machine, shoe manufacturers were able to increase production and reduce prices dramatically.

African Americans have made many significant contributions to mathematics, science, and invention. By solving the percent problems and matching the problem and the correct solution, you will learn more about just a few of them.



### Solutions

- A. 20 Benjamin Banneker
- B. 21 Majorie Lee Browne
- C. 18 Lewis Latimer
- D. 17.5 Jane Cooke Wright

1. 35% of 50 is what number?

This physician researched and tested chemotherapy as a method of treating cancer. In 1952, she became head of the Cancer Research Foundation at Harlem Hospital.

2. What percent of 75 is 15?

This mathematician was part of the team of surveyors who created the street plan for Washington, D.C. in the late eighteenth century.

3. 4.5% of 400 is what number?

In 1876, this engineer drew up the plans that accompanied Alexander Graham Bell's application for a patent on the telephone.

4. 120% of what number is 25.2?

In 1949, she became one of the first two African-American women to earn a doctorate in mathematics. She was head of the mathematics department at North Carolina Central University from 1951 to 1970.

## Periodic Cicadas

Cicadas, also commonly known as locusts, are insects that inhabit much of the eastern United States. Some cicadas are called **periodic** because they have life cycles that span periods of several years. The *Magicicada* is a kind of cicada that has an unusually long life cycle of 13 or 17 years. These 13-year and 17-year cicadas spend much of their lives living underground. After 12 or 16 years, the cicadas start to burrow upward. All at once they emerge from the ground, taking flight and eating most of the leaves on nearby plants.

While scientists do not know for sure why the *Magicicada* life cycles last for 13 or 17 years, they do have several theories. One theory is that this life cycle pattern makes it easier for the cicadas to find food. Another theory is that the pattern helps the cicada avoid predators.

**For Exercises 1–4, refer to the following information.**

Suppose there are many kinds of cicadas. For each of the pair below, find out how many years would pass before each would again emerge at the same time.

- 11-year and 15-year cicadas
- 12-year and 16-year cicadas
- 14-year and 18-year cicadas
- 13-year and 17-year cicadas
- In what year will the 13-year and 17-year cicadas that emerged in the summer of 1998 once again emerge at the same time? Explain.

**For Exercises 6–8, refer to the following information.**

Suppose the cicada has three predators that have life cycles of 2, 3, and 5 years. The population of cicadas was nearly wiped out one summer because all three predators emerged when the cicadas emerged.

- After how many years will the three predators emerge together again?
- For each of the cicada populations in Exercises 1-4, find the number of years before the cicada population would again emerge at the same time as all three predators. Record your answers in the table below.

Cicada Type	11-year	12-year	13-year	14-year	15-year	16-year	17-year	18-year
Years								

- Which two cicada populations have the best chance of survival? Explain.

## Intersection and Union of Sets

The darker shaded areas in the Venn diagrams show the *union* and *intersection* of sets  $A$  and  $B$ .

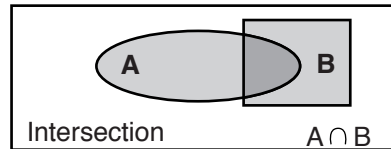
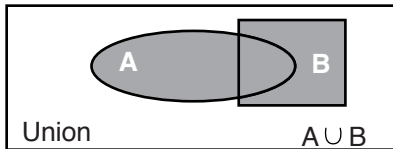

For example, if  $A = \{1, 2, 3, 4\}$  and  $B = \{3, 4, 5, 6\}$ , then their union and intersection are written as:

Union:  $A \cup B = \{1, 2, 3, 4, 5, 6\}$       Intersection:  $A \cap B = \{3, 4\}$

**Draw a Venn diagram for sets  $A$  and  $B$ . Then write the numbers included in  $A \cup B$  and  $A \cap B$ . In Exercises 2 and 4, record the numbers as decimals.**

- $A = \{\text{integers between 0 and 7}\}$   
 $B = \{\text{factors of 12}\}$
- $A = \{\text{one-place decimals between 0 and 0.5}\}$   
 $B = \{\text{fractions with 1, 2, 3, or 4 as numerator and 5 as a denominator}\}$
- $A = \{\text{perfect squares between 0 and 30}\}$   
 $B = \{\text{odd whole numbers less than 10}\}$
- $A = \left\{\frac{1}{2}, \frac{1}{3}, \frac{1}{4}, \frac{1}{5}\right\}$   
 $B = \{0.\bar{1}, 0.\bar{2}, 0.\bar{3}, 0.\bar{4}, 0.\bar{5}, 0.\bar{6}, 0.\bar{7}, 0.\bar{8}, 0.\bar{9}\}$

# 5-1 Enrichment

6NS2.1

## Fractional Areas

The figure at the right shows one square inch. Each small square equals  $\frac{1}{16}$  of a square inch.

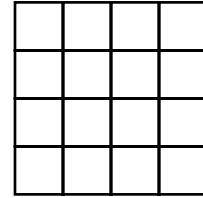

Write a fraction or mixed number for the shaded area of each drawing.

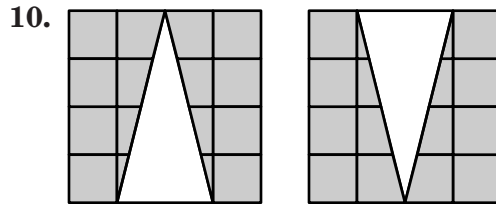
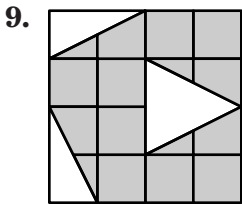
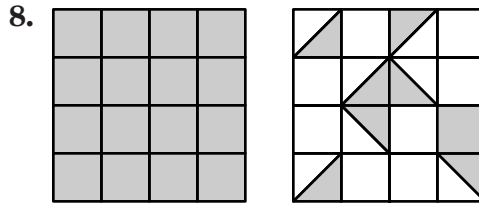
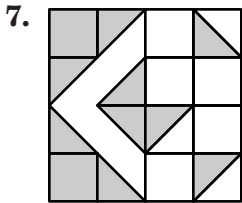
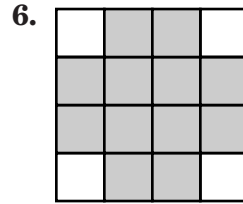
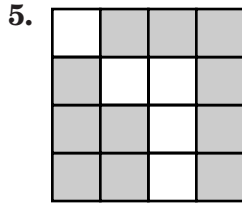
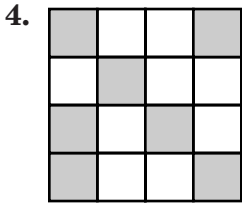
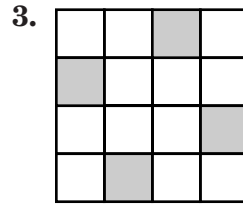
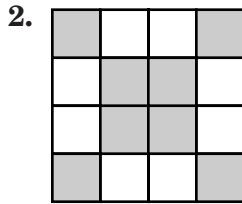
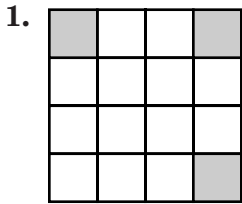

Copyright © Glencoe/McGraw-Hill, a division of The McGraw-Hill Companies, Inc.

**5-2****Enrichment****6NS2.1, 6NS2.4****Fractions Maze**

To solve this maze, start at the upper left corner. Then, draw a line to the next circle with the smallest sum or difference. The answers written in order will form a pattern.

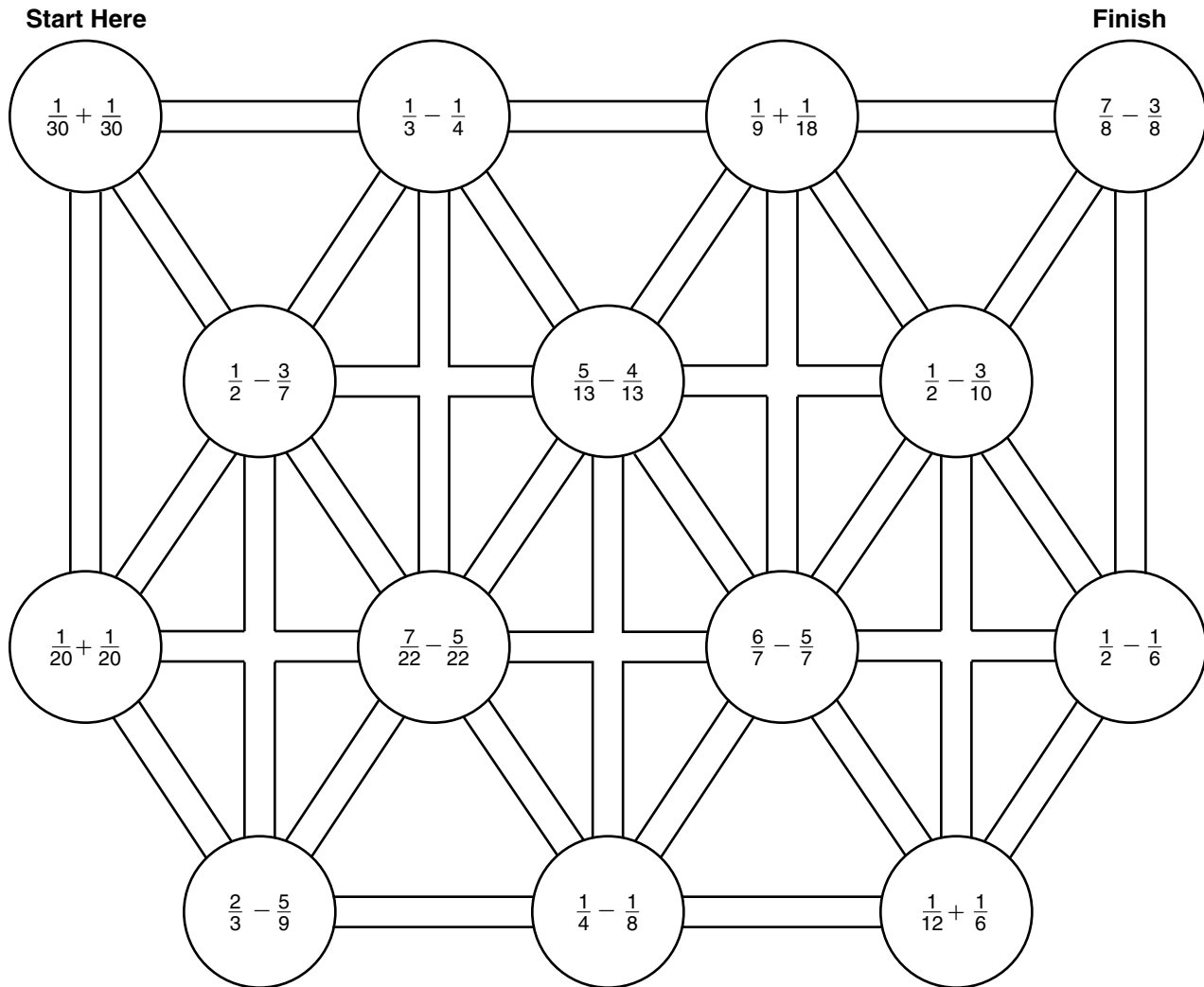

Describe the pattern in the fractions along the line you drew from start to finish.



**5-3 Enrichment****6NS2.1, 6NS2.4****Arithmetic Sequences of Fractions**

Each term in an *arithmetic* sequence is created by adding or subtracting the same number to the term before. The number added or subtracted is called the *common difference*.

The sequence below is an increasing arithmetic sequence with a common difference of  $\frac{1}{4}$ .

$$\frac{1}{8}, \frac{3}{8}, \frac{5}{8}, \frac{7}{8}, 1\frac{1}{8}$$

Below is a decreasing arithmetic sequence with a common difference of  $1\frac{1}{5}$ .

$$7\frac{3}{5}, 6\frac{2}{5}, 5\frac{1}{5}, 4, 2\frac{4}{5}$$

**Write the common difference for each arithmetic sequence.**

1.  $\frac{1}{2}, \frac{5}{8}, \frac{3}{4}, \frac{7}{8}, 1, 1\frac{1}{8}$

2.  $1\frac{1}{3}, 3\frac{5}{6}, 6\frac{1}{3}, 8\frac{5}{6}$

3.  $4\frac{1}{2}, 4\frac{2}{5}, 4\frac{3}{10}, 4\frac{1}{5}$

4.  $11, 9\frac{2}{3}, 8\frac{1}{3}, 7, 5\frac{2}{3}$

**Write the next term in each arithmetic sequence.**

5.  $\frac{2}{3}, \frac{3}{4}, \frac{5}{6}, \frac{11}{12}, 1$

6.  $\frac{13}{20}, \frac{11}{20}, \frac{9}{20}, \frac{7}{20}$

7.  $5\frac{1}{5}, 5\frac{7}{10}, 6\frac{1}{5}, 6\frac{7}{10}$

8.  $4\frac{11}{12}, 3\frac{3}{4}, 2\frac{7}{12}, 1\frac{5}{12}$

**Write the first five terms in each sequence.**

9. This increasing sequence starts with  $\frac{1}{6}$  and has a common difference of  $1\frac{1}{5}$ .

10. This decreasing sequence starts with  $6\frac{1}{3}$  and has a common difference of  $\frac{3}{4}$ .

**5-5 Enrichment****6AF2.1, 6NS2.1****Changing Measures of Length**

Fractions and mixed numbers are frequently used with customary measures.

The problems on this page will give you a chance to practice using multiplication of fractions as you change measures of lengths to different equivalent forms.

$$12 \text{ inches (in.)} = 1 \text{ foot (ft)}$$

$$3 \text{ feet} = 1 \text{ yard (yd)}$$

$$5\frac{1}{2} \text{ yards} = 1 \text{ rod (rd)}$$

$$320 \text{ rods} = 1 \text{ mile (mi)}$$

**Use a fraction or a mixed number to complete each statement. Refer to the table above as needed.**

1. 12 ft 6 in. =  ft

2. 1 rod =  ft

3.  $\frac{5}{8}$  yd =  in.

4. 10 ft =  yd

5. 7 yd 2 ft =  yd

6. 1,540 yd =  mi

7. 1,000 rd =  mi

8. 27 in. =  yd

**Use a whole number to complete each statement. Refer to the table above as needed.**

9.  $10\frac{1}{2}$  ft = 10 ft  in.

10.  $12\frac{1}{2}$  yd =  in.

11. 1 mi =  ft

12. 1 mi =  yd

13.  $\frac{1}{10}$  mi =  yd

14.  $\frac{3}{4}$  ft =  in.

15. 10 rd =  ft

16.  $\frac{3}{8}$  mi =  ft

**5-6**

**Enrichment**

6NS2.1

**Trail Blazers**

Each puzzle on this page is called a **trail blazer**. To solve it, you must find a trail that begins at any one of the small squares and ends at the goal square, following these rules.

1. The sum of all the fractions on the trail must equal the number in the goal square.
2. The trail can only go horizontally or vertically.
3. The trail cannot retrace or cross itself.

When you are solving a trail blazer, try to eliminate possibilities. For instance, in the puzzle at the right, you know that you cannot include  $\frac{3}{4}$  using  $\frac{3}{4} + \frac{1}{4} = 1$  because you can't reach the goal box.  $\frac{3}{4} + \frac{1}{2} = 1\frac{1}{4}$  will not work either as the goal for the entire trail is only 1.

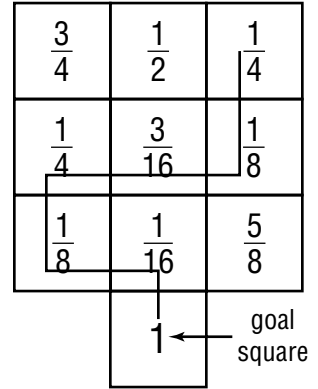

1.

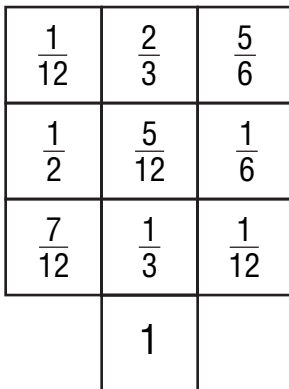

2.

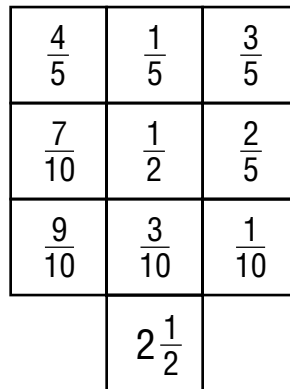

3.

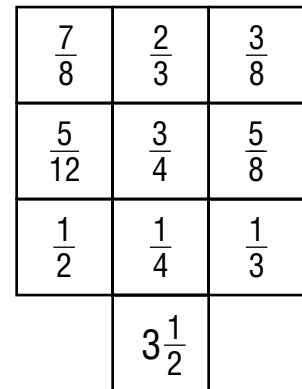

4.

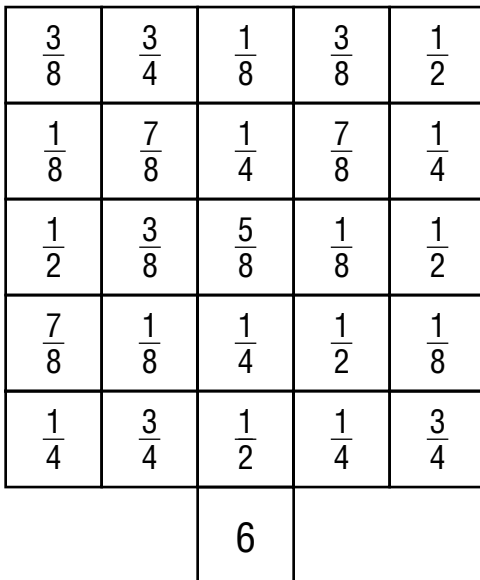

5.

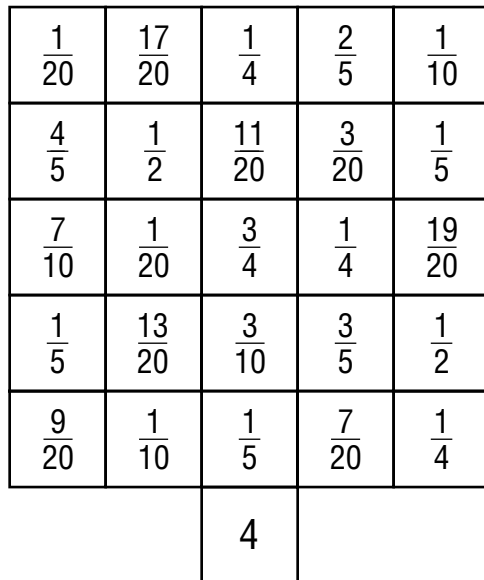

**5-7 Enrichment**

6NS2.1, 6NS2.2

**Continued Fractions**

The expression at the right is an example of a *continued fraction*. Although continued fractions may look complicated, they are just a combination of addition and division. Here is one way to simplify a continued fraction.

$$1 + \frac{1}{1 + \frac{1}{1 + \frac{1}{9}}}$$

$$\begin{aligned} 1 + \frac{1}{1 + \frac{1}{1 + \frac{1}{9}}} &= 1 + \left[ 1 \div \left( 1 + \left[ 1 \div \left( 1 + \frac{1}{9} \right) \right] \right) \right] \\ &= 1 + \left[ 1 \div \left( 1 + \left[ 1 \div \frac{10}{9} \right] \right) \right] \\ &= 1 + \left[ 1 \div \left( 1 + \frac{9}{10} \right) \right] \\ &= 1 + \left[ 1 \div \frac{19}{10} \right] \\ &= 1 + \frac{10}{19} \\ &= \frac{29}{19} \end{aligned}$$

Write each continued fraction as an improper fraction.

1.  $1 + \frac{1}{3 + \frac{1}{3}}$

2.  $2 + \frac{1}{2 + \frac{1}{2}}$

3.  $1 + \frac{2}{3 + \frac{2}{3}}$

4.  $1 + \frac{3}{3 + \frac{1}{4}}$

5.  $5 + \frac{1}{1 + \frac{1}{5}}$

6.  $2 + \frac{2}{2 + \frac{2}{5}}$

7.  $1 + \frac{1}{1 + \frac{1}{1 + \frac{1}{2}}}$

8.  $1 + \frac{1}{1 + \frac{1}{1 + \frac{1}{3}}}$

9.  $1 + \frac{1}{1 + \frac{1}{1 + \frac{1}{5}}}$

10.  $2 + \frac{1}{2 + \frac{1}{2 + \frac{1}{2}}}$

11.  $3 + \frac{1}{3 + \frac{2}{1 + \frac{1}{3}}}$

12.  $6 + \frac{1}{1 + \frac{1}{3 + \frac{1}{3}}}$

**6-1****Enrichment****6NS1.2****Golden Ratio**

The Great Pyramid at Giza utilizes a special ratio between the altitude of a triangular face and one-half the length of the base. This ratio is known as the **Golden Ratio** and has been used repeatedly by artists and architects over the centuries. It is thought to be particularly pleasing to the human eye.

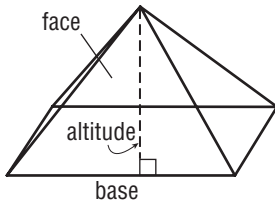

The line segment and rectangle are drawn to illustrate the relationship of the Golden Ratio.  $\frac{AB}{BC} = \frac{BC}{AC} \approx 1.618$

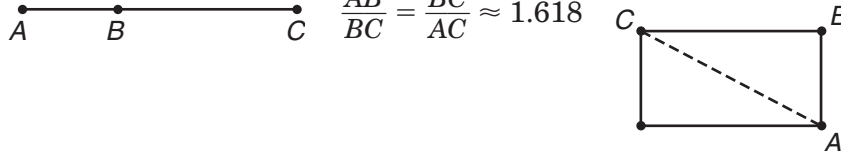
**Exercises**

Determine whether each rectangle demonstrates the Golden Ratio.

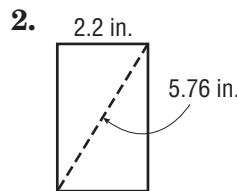
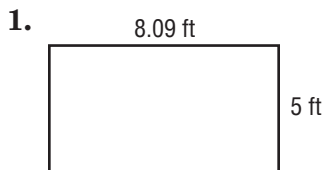

The **Fibonacci Sequence**, shown below, is related to the Golden Ratio.

0, 1, 1, 2, 3, 5, 8, 13, 21, ...

The ratio of a number to the previous number approximates the golden ratio. The greater the numbers in the sequence, the closer the approximation is to the golden ratio.

For Exercises 3–6, use the Golden Ratio to determine numbers in the Fibonacci Sequence. Round each number to the nearest whole number.

- What will the next five numbers be in the sequence?
- What will the next number be after 610?
- What will the next number be after 2,584?
- What will the next number be after 6,765?

**6-2****Enrichment****6NS1.2, 6AF2.2, 6AF2.3****An Educated Consumer**

Choosing a checking account is something that most people do at some point in their lives. Because checking accounts vary from institution to institution, and from one type of account to another, you will need to consider the options associated with each account before choosing one of them.

Suppose a bank offers two kinds of checking accounts.

**Account A:** a \$0.20 charge for writing each check and no service charge

**Account B:** a \$0.10 charge for writing each check and a monthly service charge of \$1.50

1. Which account would cost less if a person were to write 10 checks in a month?
2. Which account would cost less if a person were to write 20 checks in a month?
3. Using the guess-and-check strategy, find the number of checks that would have to be written for the cost of Account A to equal the cost of Account B. What is that cost?
4. Which account would cost less if a person were to write 250 checks in a year? By how much?
5. Diana Durbin wrote 300 checks in one year. Her total charge for the use of the account that year was \$72.00. The bank charges \$0.15 for writing one check and charges a fixed amount each month for the use of the account. What is that monthly service charge?

## Changing Measurements with Factors of 1

Multiplying an expression by the number 1 does not change its value. This property of multiplication can be used to change measurements.

Let's say you wanted to change 4.5 hours to seconds. Start by multiplying 4.5 by the number 1 written in the form  $\frac{60 \text{ minutes}}{1 \text{ hour}}$ . This first step changes 4.5 hours to minutes.

$$4.5 \text{ hours} \times \frac{60 \text{ minutes}}{1 \text{ hour}}$$

Now, multiply by the number 1 again. This time use the fact that

$$1 = \frac{60 \text{ seconds}}{1 \text{ minute}}$$

$$4.5 \cancel{\text{ hours}} \times \frac{60 \cancel{\text{ minutes}}}{1 \cancel{\text{ hour}}} \times \frac{60 \text{ seconds}}{1 \cancel{\text{ minute}}} = 16,200 \text{ seconds}$$

**Complete by writing the last factor and the answer. You may need to use a table of measurements to find the factors.**

1. Change 5 pints to fluid ounces.

$$5 \text{ pints} \times \frac{2 \text{ cups}}{1 \text{ pint}} \times$$

2. Change 0.8 miles to inches.

$$0.8 \text{ mile} \times \frac{5,280 \text{ feet}}{1 \text{ mile}} \times$$

3. Change 4 square yards to square inches.

$$4 \text{ yd}^2 \times \frac{9 \text{ ft}^2}{1 \text{ yd}^2} \times$$

4. Change 12 bushels to pints.

$$12 \text{ bushels} \times \frac{4 \text{ pecks}}{1 \text{ bushel}} \times \frac{8 \text{ quarts}}{1 \text{ peck}} \times$$

5. Change one-half of an acre to square inches.

$$\frac{1}{2} \text{ acre} \times \frac{4,840 \text{ yd}^2}{1 \text{ acre}} \times \frac{9 \text{ ft}^2}{1 \text{ yd}^2} \times$$

**6-4 Enrichment****6AF2.1****Using a Measurement Conversion Chart**

You may sometimes want to convert customary measurements to metric measurements. For example, suppose you are reading about horses and want to know how long 5 furlongs are.

Start by finding a conversion table such as the one shown here. (Dictionaries often include such tables.)

1 mil	= 0.001 inch	= 0.0254 millimeter
1 inch	= 1,000 mil	= 2.54 centimeters
12 inches	= 1 foot	= 0.3048 meter
3 feet	= 1 yard	= 0.9144 meter
$5\frac{1}{2}$ yards, or $16\frac{1}{2}$ feet	= 1 rod	= 5.029 meters
40 rods	= 1 furlong	= 201.168 meters
8 furlongs	} = 1 (statute) mile	= 1.6093 kilometers
5,280 feet		
1,760 yards		
3 miles	= 1 (land) league	= 4.828 kilometers

To change from a large unit to a small unit, multiply. To change from a small unit to a large one, divide.

**Example 1** Change 5 furlongs to meters.

$$5 \times 201.168 = 1,005.84$$

So, 5 furlongs is about 1,000 meters, or 1 kilometer.

**Change each measurement to a metric measurement. Round each answer to the nearest tenth.**

- 10 yards
- 100 leagues
- 10 inches
- 100 rods
- 1,000 mils
- 10 feet
- 50 miles
- 50 furlongs
- 50 inches
- 200 feet
- 200 miles
- 200 yards



**6-5**

**Enrichment**

6NS1.3

**What Am I?**

Solve each proportion. Then, starting at the box marked with the heavy outline, draw an arrow to the adjacent box containing the variable with the least value. (You may move horizontally or vertically. You may use each box at most once.)

	$\frac{3.5}{\frac{1}{4}} = \frac{o}{2}$	$\frac{n}{37} = \frac{54}{55\frac{1}{2}}$	$\frac{5}{e} = \frac{2\frac{1}{2}}{21}$	$\frac{16.5}{36} = \frac{11}{a}$
$\frac{z}{2} = \frac{4}{1}$	$\frac{0.7}{h} = \frac{2.1}{108}$	$\frac{0.3}{0.4} = \frac{18}{o}$	$\frac{3}{5.82} = \frac{n}{48.5}$	$\frac{p}{55} = \frac{\frac{2}{5}}{1}$
$\frac{a}{5} = \frac{9}{15}$	$\frac{2}{7} = \frac{p}{14}$	$\frac{0.5}{i} = \frac{24}{384}$	$\frac{z}{32} = \frac{7}{8}$	$\frac{43.2}{18} = \frac{u}{5}$
$\frac{4}{o} = \frac{20}{30}$	$\frac{3.4}{6.8} = \frac{2.5}{r}$	$\frac{\frac{2}{9}}{\frac{1}{3}} = \frac{t}{18}$	$\frac{\frac{1}{3}}{z} = \frac{\frac{2}{3}}{60}$	$\frac{72}{\frac{1}{2}} = \frac{t}{\frac{1}{4}}$
$\frac{p}{\frac{1}{2}} = \frac{16}{2}$	$\frac{o}{24} = \frac{10.5}{36}$	$\frac{3.5}{5.5} = \frac{7}{r}$	$\frac{2\frac{1}{2}}{9} = \frac{5}{l}$	<b>Stop here.</b> $\frac{e}{\frac{1}{5}} = \frac{12.5}{\frac{1}{2}}$
$\frac{600}{150} = \frac{o}{3.5}$	$\frac{1\frac{2}{5}}{1.4} = \frac{r}{20}$	$\frac{0.2}{o} = \frac{0.5}{35}$	$\frac{3}{8} = \frac{6}{d}$	$\frac{1}{4} = \frac{3}{96}$

Now fill in the table below with the letters in the order in which you found them. Now you can say what I am.

--	--	--	--	--	--	--	--	--	--	--	--	--	--	--	--	--	--	--	--

**Scale Drawings**

Use the scale drawings of two different apartments to answer the questions.

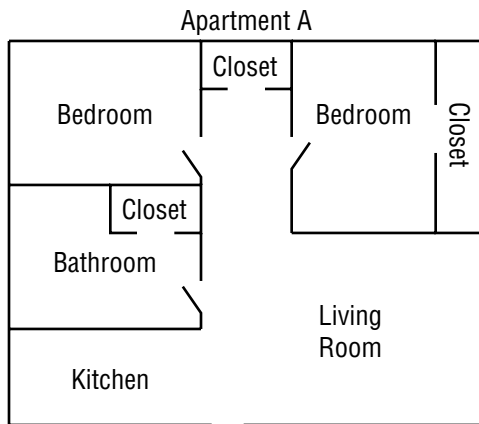

Scale: 1 inch = 12 feet

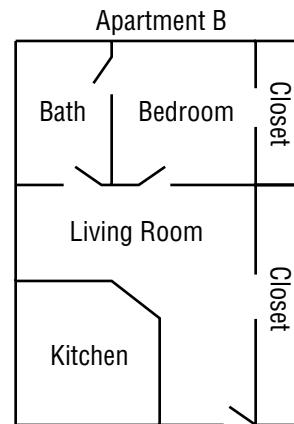

Scale: 1 inch = 16 feet

- Which apartment has the greater area?
- What is the difference in square feet between Apartment A and Apartment B?
- How much more closet space is offered by Apartment B than Apartment A?
- How much more bathroom space is offered by Apartment B than Apartment A?
- A one-year lease for Apartment A costs \$450 per month. A one-year lease for Apartment B costs \$525 per month. Which apartment offers the greatest value in terms of the cost per square foot?

**Shaded Regions**

The fractions or percents listed below each represent one of the shaded regions.

Match each fraction or percent with the shaded region it represents.

1.  $\frac{1}{2}$

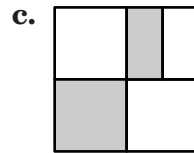
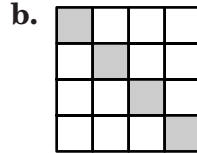
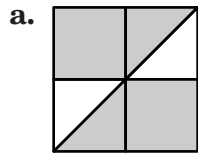

2.  $\frac{25}{64}$

3.  $\frac{11}{16}$

4. 25%

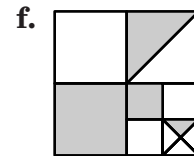
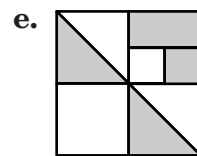
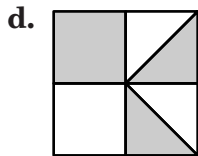

5.  $\frac{3}{4}$

6.  $62\frac{1}{2}\%$

7.  $\frac{29}{64}$

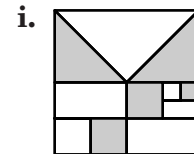
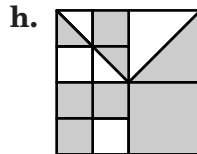
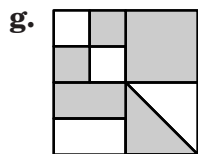

8. 37.5%

9.  $\frac{7}{16}$

**6-9****Enrichment**

6NS1.1

***Juan de la Cierva***

Helicopters became widely used in the early 1950s. However, did you know that a similar aircraft was developed in Spain nearly thirty years earlier? The inventor was Juan de la Cierva (1895–1936), and for many years his aircraft were used in rescue work. The modern helicopter is faster and more versatile, but it retains many features of Cierva’s design.

Fill in the blanks below to find what Cierva called his aircraft. On the line next to the decimal, fraction, or mixed number, write the letter matching the answer. If you have found the percents correctly, the letters read downward will spell out the name of the aircraft.

- |                    |       |          |
|--------------------|-------|----------|
| 1. $\frac{3}{2}$   | _____ | A 150%   |
| 2. 0.006           | _____ | G 0.029% |
| 3. 3.2             | _____ | I 0.006% |
| 4. 2.9             | _____ | O 350%   |
| 5. 0.00029         | _____ | O 290%   |
| 6. 0.00006         | _____ | R 0.5%   |
| 7. $\frac{1}{200}$ | _____ | T 320%   |
| 8. $3\frac{1}{2}$  | _____ | U 0.6%   |

**7-1**

**Enrichment**

6NS1.4

**Model Behavior**

When a block is painted and then separated into small cubes, some of the faces of the cubes will have paint on them and some will not.

**For each set of blocks determine the percent of cubes that are painted on the given number of faces.**

- 1. 0 faces
- 2. 1 face
- 3. 2 faces
- 4. 3 faces
- 5. 4 faces
- 6. 5 faces
- 7. 6 faces

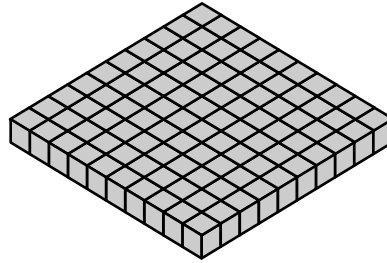

- 8. 0 faces
- 9. 1 face
- 10. 2 faces
- 11. 3 faces
- 12. 4 faces
- 13. 5 faces
- 14. 6 faces

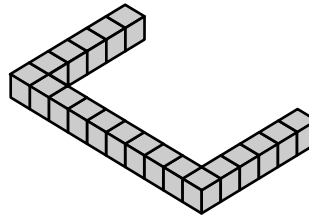

- 15. 0 faces
- 16. 1 face
- 17. 2 faces
- 18. 3 faces
- 19. 4 faces
- 20. 5 faces
- 21. 6 faces

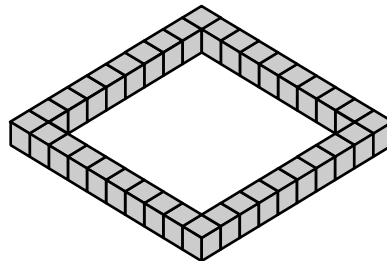

# 7-2

## Enrichment

6NS1.3, 6NS1.4

### Made in the Shade

To shade 25% of the figure below, ask yourself how many of the eight squares need to be shaded. Then use the percent proportion to find the answer.

$$\frac{x}{8} = \frac{25}{100}$$

$$100x = 8 \times 25$$

$$\frac{100x}{100} = \frac{200}{100}$$

$$x = 2$$

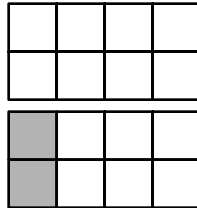

If you shade two squares, you have shaded 25% of the figure.

**Shade the indicated percent of each diagram.**

1. Shade 40%.

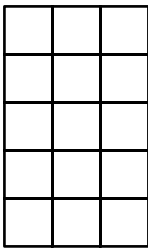

2. Shade 37.5%.

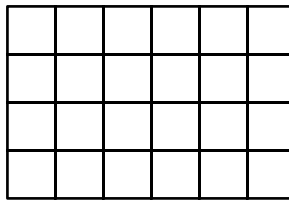

3. Shade  $16\frac{2}{3}\%$ .

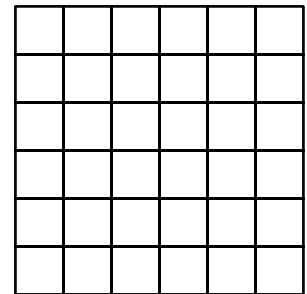

**Shade the indicated percent of each diagram. You will need to divide the squares in each diagram into smaller squares.**

4. Shade 30%.

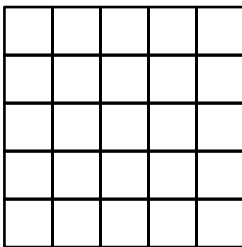

5. Shade 62.5%.

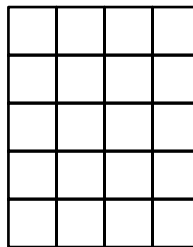

6. Shade 27.5%.

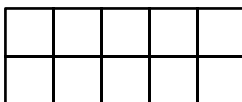

7. Shade 28.125%.

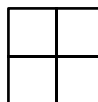

**7-3****Enrichment****6NS1.4*****The History of %***

Math historians believe that the percent symbol, %, may have been developed from the symbol,  $\text{P} \frac{\circ}{\text{C}}$ , that first appeared in an Italian writing dating back to 1425. At that time, percent was commonly written as “per 100”, “P cento”, and as a circle directly above a number,  $\overset{\circ}{\text{C}}$ . Roman Numerals were also used to represent a percent. For example, “xx.per.c.” meant 20 percent. The symbol continued to develop in mathematical writings as, Per  $\frac{\circ}{\text{O}}$ , around 1650 to,  $\frac{\circ}{\text{O}}$ , and eventually to our modern symbol, %.

**Find the estimates below to reveal the meaning of a similar symbol, %.**

**R** 32% of 123**S** 90% of 138**T** 12% of 50**O** 110% of 20**N** 25% of 83**P**  $\frac{1}{4}\%$  of 240**E** 78% of 20**U** 152% of 41**A**  $\frac{1}{2}\%$  of 18**H** 0.3% of 62**D** 25.3% of 125

_____	_____	_____
0.6	15	41

_____	_____	_____	_____	_____	_____	_____	_____	_____
5	0.2	22	60	126	0.09	20	31	

**7-4****Enrichment****6NSI.4, 6AFI.1*****Inherited Traits***

Everyone inherits traits like eye color, hair color, and skin pigmentation from their parents and grandparents, but there are other interesting traits that are also inherited. Right or left handedness is an inherited trait, as are dimples in one's cheeks. The chart below shows some inherited traits and the percentage of the general population that shows the trait.

Trait	Percent of General Population
Right-handedness	87%
Left-handedness	13%
Dimples	75%
Earlobes attached	25%
Able to roll tongue	65%

Source: [www.extension.usu.edu/aitc](http://www.extension.usu.edu/aitc) and [www.anythingleft-handed.co.uk](http://www.anythingleft-handed.co.uk)

- Based on the information presented above, predict how many of your classmates will have each of these traits.

Trait	Number of Students
Right-handedness	
Left-handedness	
Dimples	
Earlobes attached	
Able to roll tongue	

- Survey your classmates to find how many have these traits.

Trait	Number of Students	Percent of Students
Right-handedness		
Left-handedness		
Earlobes attached		
Able to roll tongue		
Dimples		

- Compare your predictions to your actual results.

- How do the class traits compare to the traits of the general population?



**7-6****Enrichment**

6NS1.2

**A Taxing Exercise**

People who earn income are required by law to pay taxes. The amount of tax a person owes is computed by first subtracting the amount of all *exemptions* and *deductions* from the amount of income, then using a tax table like this.

**Schedule X**—Use if your filing status is **Single**

If the amount on Form 1040, line 37, is: <i>Over</i> —	<i>But not over</i> —	Enter on Form 1040, line 38	<i>of the amount over</i> —
\$0	\$20,350	-----15%	\$0
20,350	49,300	\$3,052.50 + 28%	20,350
49,300	-----	11,158.50 + 31%	49,300

**Compute each person's income. Subtract \$5,550 for each person's exemption and deduction. Then use the tax rate schedule to compute the amount of federal tax owed.**

1. A cashier works 40 hours each week, earns \$7.50 per hour, and works 50 weeks each year.
2. A newspaper carrier works each day, delivers 154 papers daily, and earns \$0.12 delivering each paper.
3. A baby-sitter earns \$3.50 per hour per child. During a year, the baby-sitter works with two children every Saturday for 8 hours and with three children every other Sunday for 6 hours.
4. While home from college for the summer, a painter earns \$17.00 per hour, working 45 hours each week for 15 weeks.
5. Working before and after school in the school bookstore, an employee works 2.5 hours each day for 170 days and earns \$4.60 per hour.
6. After graduating from college, a computer programmer accepts a position earning \$2,450 monthly.

**Taxes**

Texas is one of the few states that does not impose a state income tax on residents. However, the state does collect sales and use taxes. The Texas state sales tax rate is 6.25%. Local taxing authorities can require additional tax of up to 2%, raising the total possible tax rate to 8.25%.

Use the Sales and Use Tax Chart below to solve the following problems.

Texas City	Total Sales and Use Tax
Abilene	8.25%
Corral City	8%
Sadler	7.25%
Ackerly	7.75%
San Antonio	8.125%
Raccoon Bend	6.75%
Dallas	8.25%

Source: window.state.tx.us

- Kendra purchases a sweater that costs \$24.99 at the Corral City Mall. What is the total cost of the sweater?
- Brandon agrees to buy a new car for \$21,525. As an employee of the company that produces the car, he is entitled to an additional 15% discount. He must pay the Dallas City sales tax. What is the total amount Brandon will pay for his new car?
- While at the Abilene Outlet Store, Barbara purchases an outfit that is regularly priced \$113.49 on sale for \$99.00. What is the percent of discount?
- Sara pays a total of \$32.43 for an item after a 25% discount and the Ackerly City tax were applied. What is the original amount of Sara's purchase?
- Davis makes a list of the cost of each item he would like to buy with his \$100.00 gift card. Determine if Davis has enough money to purchase everything on his list after the Sadler City tax is applied. If not, how much more money will he need? If so, what is the gift card balance?

Item	Cost of Item
CD	\$14.99
DVD	\$19.99
Headphones	\$59.99

**Taking an Interest**

When interest is paid on both the amount of the deposit and any interest already earned, interest is said to be **compounded**. You can use the formula below to find out how much money is in an account for which interest is compounded.

$$A = P(1 + r)^n$$

In the formula,  $P$  represents the principal, or amount deposited,  $r$  represents the rate applied each time interest is paid,  $n$  represents the number of times interest is given, and  $A$  represents the amount in the account.

**Example** A customer deposited \$1,500 in an account that earns 8% per year. If interest is compounded and earned semiannually, how much is in the account after 1 year?

Use the formula  $A = P(1 + r)^n$ .

Since interest is earned semiannually,  $r = 8 \div 2$  or 4% and  $n = 2$ .

$$\begin{aligned} A &= 1,500(1 + 0.04)^2 && \text{Use a calculator.} \\ &= 1,622.40 \end{aligned}$$

After 1 year, there is \$1,622.40 in the account.

**Exercises**

Use the compound interest formula and a calculator to find the value of each of these investments. Round each answer to the nearest cent.

- \$2,500 invested for 1 year at 6% interest compounded semiannually
- \$3,600 invested for 2 years at 7% interest compounded semiannually
- \$1,000 invested for 5 years at 8% interest compounded annually
- \$2,000 invested for 6 years at 12% interest compounded quarterly
- \$4,800 invested for 10 years at 9% interest compounded annually
- \$10,000 invested for 15 years at 7.5% interest compounded semiannually

**8-1****Enrichment****6SDAPI.1, 6SDAPI.2****Enhanced Line Plots**

You have learned to create line plots to analyze given data. Sometimes altering a line plot can show even more information about a data set.

**SPORTS** For Exercises 1–4, use the following data about the Super Bowl.

The National Football League began choosing its champion in the Super Bowl in 1967. The list below shows the margin of victory and the winning league for the first 40 Super Bowl games. In the list, A indicates that the winning team is from the American Football Conference (AFC), N indicates that the winning team is from the National Football Conference.

Year	Margin	Year	Margin	Year	Margin	Year	Margin
1	25-N	11	18-A	21	19-N	31	14-N
2	19-N	12	17-N	22	32-N	32	7-A
3	9-A	13	4-A	23	4-N	33	15-A
4	16-A	14	12-A	24	45-N	34	7-N
5	3-A	15	17-A	25	1-N	35	27-A
6	21-N	16	5-N	26	13-N	36	3-A
7	7-A	17	10-N	27	35-N	37	27-N
8	17-A	18	29-A	28	17-N	38	3-A
9	10-A	19	22-N	29	23-N	39	3-A
10	4-A	20	36-N	30	10-N	40	11-A

1. Make a line plot of the numerical data.

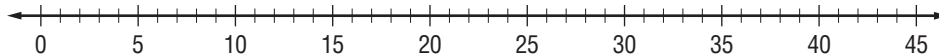

2. What do you observe about the winning margins?
3. Make a new line plot for the winning margins by replacing each  $\times$  with A for an AFC win or N for an NFC win. What do you observe about the winning margins when looking at this enhanced line plot?

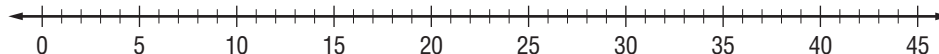

4. The list of Super Bowl margins is given in order of years: first 25-N, then 9-N, and so on. Describe any patterns you see in the margins or in the winning league over the years of the Super Bowl.

## Quartiles

The median is a number that describes the “center” of a set of data. Here are two sets with the same median, 50, indicated by  $\bigcirc$ .

25	30	$\nabla$ 35	40	45	$\bigcirc$ 50	55	60	$\triangle$ 65	70	75
0	10	$\nabla$ 20	40	50	$\bigcirc$ 50	60	70	$\triangle$ 80	90	100

But, sometimes a single number may not be enough. The numbers shown in the triangles can also be used to describe the data. They are called *quartiles*. The lower quartile is the median of the lower half of the data. It is indicated by  $\nabla$ . The upper quartile is the median of the upper half. It is indicated by  $\triangle$ .

**Circle the median in each set of data. Draw triangles around the quartiles.**

1. 

29	52	44	37	27	46	43	60	31	54	36
----	----	----	----	----	----	----	----	----	----	----

2. 

1.7	0.4	1.4	2.3	0.3	2.7	2.0	0.9	2.7	2.6	1.2
-----	-----	-----	-----	-----	-----	-----	-----	-----	-----	-----

3. 

1,150	1,600	1,450	1,750	1,500	1,300	1,200
-------	-------	-------	-------	-------	-------	-------

4. 

5	2	9	7	9	3	7	8	7	2	5	6	9	5	1
---	---	---	---	---	---	---	---	---	---	---	---	---	---	---

**Use the following set of test scores to solve the problems.**

71 57 29 37 53 41 25 37 53 27  
62 55 75 48 66 53 66 48 75 66

5. Which scores are “in the lower quartile”?

6. How high would you have to score to be “in the upper quartile”?



**8-4**

**Enrichment**

**6SDAP2.3**

**Bar Graphs and Histograms**

You can use a bar graph to compare different data sets. Bar graphs can be used to show categorical data. Solid bars are used to show the values in certain categories. You can use a histogram, which is a special kind of bar graph, to represent numerical data. It shows how many data points are within certain numerical intervals.

- These two bar graphs show the same data from the Smith family's 5-day road trip. Describe what each graph is showing and give each graph a title. Which graph is a histogram?

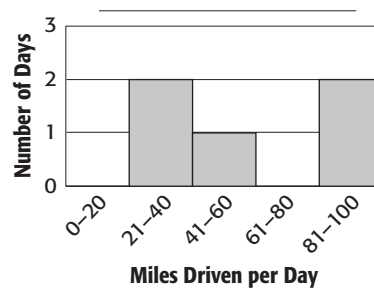
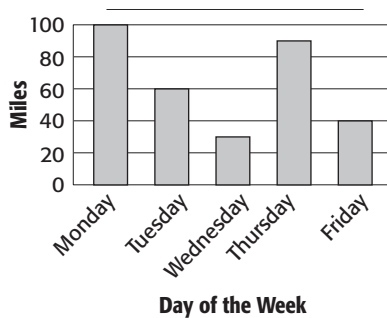

- The following two graphs show the amount of time that the family spent driving during the same road trip. Use the bar graph on the left to create a histogram on the right. Provide a title for each graph.

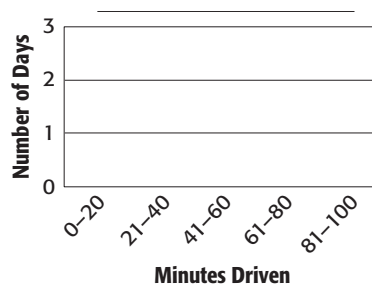
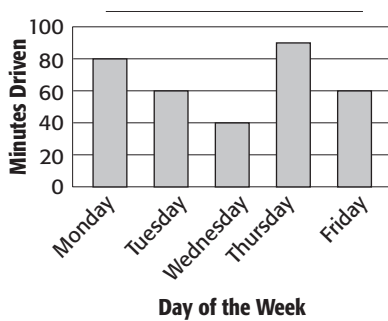

- Use the graphs to determine the average speed the Smith family drove on Wednesday.

**8-6****Enrichment****6MR2.3, 6SDAP2.5****Periodic Relationships**

You have studied scatter plots that demonstrate positive, negative, or no relationship. A **periodic relationship** is another way that two variables can be related. Periodic relationships contain patterns that repeat over time. For example, average monthly temperatures vary on a year basis. The table at right shows the average daily high temperature for each month in Los Angeles and Boston.

Temperature (°F)		
Month	Los Angeles	Boston
1	64	36
2	63	39
3	68	41
4	69	57
5	76	68
6	80	80
7	80	78
8	82	81
9	81	73
10	76	65
11	71	56
12	66	46

Source: www.wrh.noaa.gov

1. Draw a scatter plot of the data for each city on the axes below. Use a different symbol for each city (for example, an x for Los Angeles temperatures and an • for Boston temperatures).
2. Describe the trend in the data for the monthly average temperature in Boston.
3. Draw a curved line on the graph that demonstrates the trend in the data.
4. What will happen between month 12 and month 24? Describe what you think will happen for each city, and draw curved lines on the graph above to demonstrate the trends.



**8-7****Enrichment****6SDAP2.2, 6SDAP2.5****Can You Predict The Future?**

Many businesses need to be able to accurately predict the choices their customer will make. Their predictions are often based on survey results of a small population, which they apply to a larger population.

Suppose that school administrators want to know whether new technologies improve student achievement. They ask you to survey the students in your class.

**SURVEY**

1. Which of the following technologies do you have: personal computer, electronic organizer, cellular phone, internet access?
2. Which, if any, do you use to help with your school work?
3. What other technologies do you think might be helpful when completing your school work?

Based on your results from the students in your class, predict the following if there are 212 students in your grade, and a total of 639 students in the school.

**Exercises**

1. How many students in your grade have
  - a. a personal computer?
  - b. an electronic organizer?
  - c. a cellular phone?
  - d. internet access?
2. What percent of students in the entire school will have all four of the technologies asked about in the survey?
3. Which technology is used most often to help complete school work? Predict the number of students in your grade that use this technology when completing their school work.
4. Based on the results of your survey, what other type of technology would most students use to complete their school work? How many students in your school would use this technology?
5. Based on the results of your survey, what predictions or recommendations would you make to your school administrators on how to improve student achievement?

**8-8**

**Enrichment**

**6SDAP2.1, 6SDAP2.2,  
6SDAP2.5**

**Using Sampling to Predict**

According to the bar graph below, sports video game companies are leading in games sold to children and adults throughout the country. If these companies want to continue to lead in sales they will have to make sure they create games with graphics and features that their customers want. One way to do that is through customer surveys.

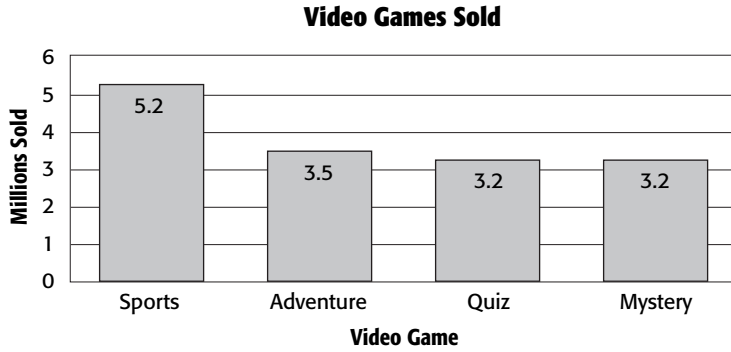

In the space below create your own customer survey for a video game. Make sure to ask questions that will give you information to create the best game possible.

**8-9**

**Enrichment**

6SDAP2.3, 6SDP2.4

**Misleading Statistics**

We hear numbers and statistics every day. A radio station says, “We’re number 1!” A store advertises, “Lowest prices in town!” The radio station and the store want us to believe their claims. But should we? Sometimes advertisers use statistics that are accurate, but do not tell the whole story. They use *misleading* statistics to help sell their products. What makes the statistics misleading is not what is said, but what is **not** said.

The radio station that says it is “Number 1” may be number 1 in terms of the number of CDs it owns, or the size of its station, or the number of people it employs. But, the station wants people to think it is number 1 in listeners. The statistic is misleading because it does not say what the station is number 1 in.

1. Explain why a store’s advertisement saying it has the “lowest prices in town” may be misleading.
2. Fode has a start-up internet business. One day, he had 1000 hits to his web site. He told advertisers that he had “30,000 hits each month.” Why might this statistic be misleading?

3. Graphs can also be misleading. A consumer group wants to show that the price of gasoline has “skyrocketed” over the past five years. The group made this line graph from the data in the table below.

Year	2000	2001	2002	2003	2004	2005
Cost per gallon	\$1.35	\$1.43	\$1.56	\$1.76	\$1.88	\$2.20

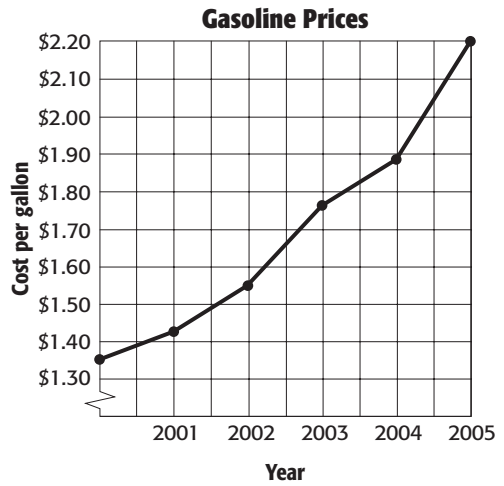

Why is this graph misleading?

4. Graph the data from Exercise 3 on the grid at the right. How does your graph that starts the y-axis scale at 0 compare to the one above?

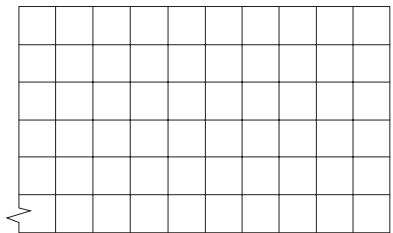

Copyright © Glencoe/McGraw-Hill, a division of The McGraw-Hill Companies, Inc.

**Lesson 8-9**

**9-1**

**Enrichment**

**6SDAP3.1**

**Coin-Tossing Experiments**

If a coin is tossed 3 times, there are 8 possible outcomes. They are listed in the table below.

Number of Heads	0	1	2	3
Outcomes	TTT	HTT	HHT	HHH
		THT	THH	
		TTH	HTH	

Once all the outcomes are known, the probability of any event can be found. For example, the probability of getting 2 heads is  $\frac{3}{8}$ . Notice that this is the same as getting 1 tail.

1. A coin is tossed 4 times. Complete this chart to show the possible outcomes.

Number of Heads	0	1	2	3	4
Outcomes	TTTT				

2. What is the probability of getting all tails?
3. Now complete this table. Make charts like the one in Exercise 1 to help find the answers. Look for patterns in the numbers.

Number of Coin Tosses	2	3	4	5	6	7	8
Total Outcomes							
Probability of Getting All Tails							

4. What happens to the number of outcomes? the probability of all tails?

Copyright © Glencoe/McGraw-Hill, a division of The McGraw-Hill Companies, Inc.

**9-2**

**Enrichment**

**6SDAP3.1**

**Probabilities and Regions**

The spinner at the right can be used to indicate that the probability of landing in either of two regions is  $\frac{1}{2}$ .

$$P(A) = \frac{1}{2} \quad P(B) = \frac{1}{2}$$

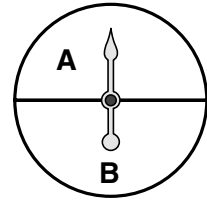

**Read the description of each spinner. Using a protractor and ruler, divide each spinner into regions that show the indicated probability.**

- Two regions A and B: the probability of landing in region A is  $\frac{3}{4}$ .  
What is the probability of landing in region B?

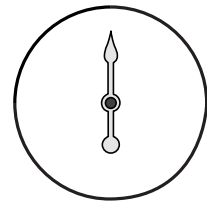

- Three regions A, B, and C: the probability of landing in region A is  $\frac{1}{2}$  and the probability of landing in region B is  $\frac{1}{4}$ . What is the probability of landing in region C?

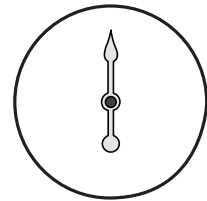

- Three regions A, B, and C: the probability of landing in region A is  $\frac{3}{8}$  and the probability of landing in region B is  $\frac{1}{8}$ . What is the probability of landing in region C?

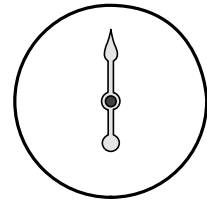

- Four regions A, B, C, and D: the probability of landing in region A is  $\frac{1}{16}$ , the probability of landing in region B is  $\frac{1}{8}$ , and the landing probability of in region C is  $\frac{1}{4}$ . What is the probability of landing in region D?

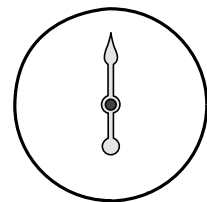

- The spinner at the right is an equilateral triangle, divided into regions by line segments that divide the sides in half. Is the spinner divided into regions of equal probability?

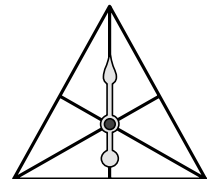

**9-3****Enrichment****6SDAP3.1****Curious Cubes**

If a six-faced cube is rolled any number of times, the theoretical probability of the cube landing on any given face is  $\frac{1}{6}$ .

**Each cube below has six faces and has been rolled 100 times. The outcomes have been tallied and recorded in a frequency table. Based on the data in each frequency table, what can you say are probably on the unseen faces of each cube?**

1.

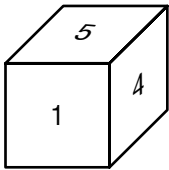

Outcome	Tally
1	15
2	14
3	18
4	16
5	19
6	18

2.

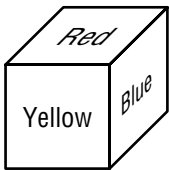

Outcome	Tally
blue	17
red	30
yellow	53

3.

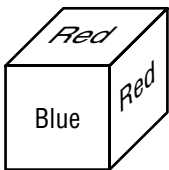

Outcome	Tally
red	30
blue	16
blank	54

4.

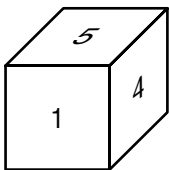

Outcome	Tally
1	34
4	32
5	34

5.

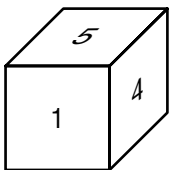

Outcome	Tally
1	14
5	13
4	18
2	16
blank	39

## Cyclic Permutations

1. George, Alan, and William are in the same math class. George has five different shirts and wears a different one each day. In how many ways can George wear his five shirts in five days?
2. Alan has three different shirts and William has four. Which of the three students, George, Alan, or William, goes the greatest number of days before he has to wear a shirt for the second time? Explain.

George, Alan, and William always wear their shirts in the same order. Suppose that George's 5 shirts are red, tan, green, black, and white. He wears his shirts following this pattern:

*B W R T G B W R T ...*

No matter where George is in the pattern, his friends can always figure out which shirt George will wear next. Since these permutations are the same when they make up part of a cycle, they are called **cyclic permutations**.

3. Alan has shirts that are white, black, and purple. Make an organized list of all the different permutations.
4. How many different ways are there for Alan to wear his shirts so that his friends recognize different patterns? Explain.
5. William has athletic shirts that are labeled 1, 2, 3, and 4. Make an organized list of all the different permutations.
6. How many different ways are there for William to wear his shirts so that his friends recognize different patterns? Explain.
7. **CHALLENGE** For any given number of shirts, how can you determine the number of ways a person could wear the shirts to produce unique patterns?

**9-5****Enrichment****6SDAP3.1****From Impossible to Certain Events**

A probability is often expressed as a fraction. As you know, an event that is impossible is given a probability of 0 and an event that is certain is given a probability of 1. Events that are neither impossible nor certain are given a probability somewhere between 0 and 1. The probability line below shows relative probabilities.

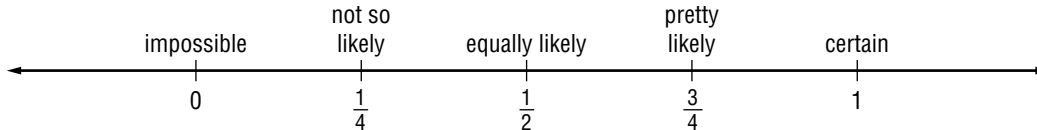

**Determine the probability of an event by considering its place on the diagram above.**

1. Medical research will find a cure for all diseases.
2. There will be a personal computer in each home by the year 2010.
3. One day, people will live in space or under the sea.
4. Wildlife will disappear as Earth's human population increases.
5. There will be a fifty-first state in the United States.
6. The sun will rise tomorrow morning.
7. Most electricity will be generated by nuclear power by the year 2010.
8. The fuel efficiency of automobiles will increase as the supply of gasoline decreases.
9. Astronauts will land on Mars.
10. The percent of high school students who graduate and enter college will increase.
11. Global warming problems will be solved.
12. All people in the United States will exercise regularly within the near future.



**9-7**

**Enrichment**

**6SDAP3.2**

**Rolling a Dodecahedron**

A **dodecahedron** is a solid. It has twelve faces, and each face is a pentagon.

At the right, you see a dodecahedron whose faces are marked with the integers from 1 through 12. You can roll this dodecahedron just as you roll a number cube. With the dodecahedron, however, there are *twelve* equally likely outcomes.

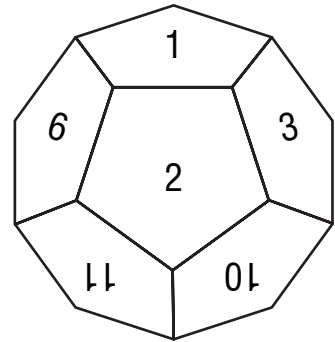

**Refer to the dodecahedron shown at the right. Find the probability of each event.**

- 1.  $P(5)$
- 2.  $P(\text{odd})$
- 3.  $P(\text{prime})$
- 4.  $P(\text{divisible by } 5)$
- 5.  $P(\text{less than } 4)$
- 6.  $P(\text{fraction})$

You can make your own dodecahedron by cutting out the pattern at the right. Fold along each of the solid lines. Then use tape to join the faces together so that your dodecahedron looks like the one shown above.

- 7. Roll your dodecahedron 100 times. Record your results on a separate sheet of paper, using a table like this.

Outcome	Tally	Frequency
1		
2		

- 8. Use your results from Exercise 7. Find the experimental probability for each of the events described in Exercises 1–6.

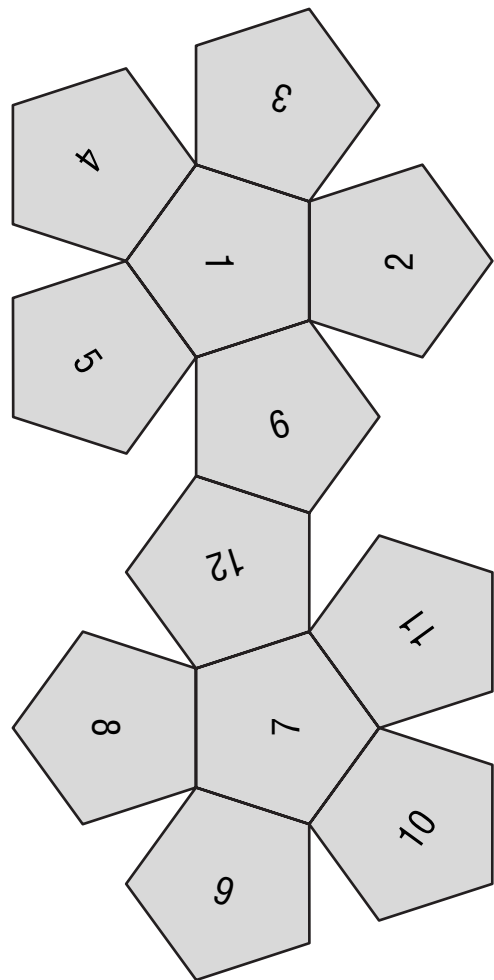

Copyright © Glencoe/McGraw-Hill, a division of The McGraw-Hill Companies, Inc.

**9-8****Enrichment****6SDAP3.4, 6SDAP3.5****Compound Events**

The game of roulette is played by dropping a ball into a spinning, bowl-shaped wheel. When the wheel stops spinning, the ball will come to rest in any of 38 locations.

On a roulette wheel, the eighteen even numbers from 2 through 36 are colored red and the eighteen odd numbers from 1 through 35 are colored black. The numbers 0 and 00 are colored green.

To find the probability of two independent events, the results of two spins, find the probability of each event first.

$$P(\text{red}) = \frac{18}{38} \text{ or } \frac{9}{19}$$

$$P(\text{black}) = \frac{18}{38} \text{ or } \frac{9}{19}$$

Then multiply.

$$P(\text{red, then black}) = \frac{9}{19} \times \frac{9}{19} \text{ or } \frac{81}{361}$$

**Find each probability.**

- black, then black
- prime number, then a composite number
- a number containing at least one 0, then a number containing at least one 2
- red, then black
- the numbers representing your age, month of birth, and then day of birth

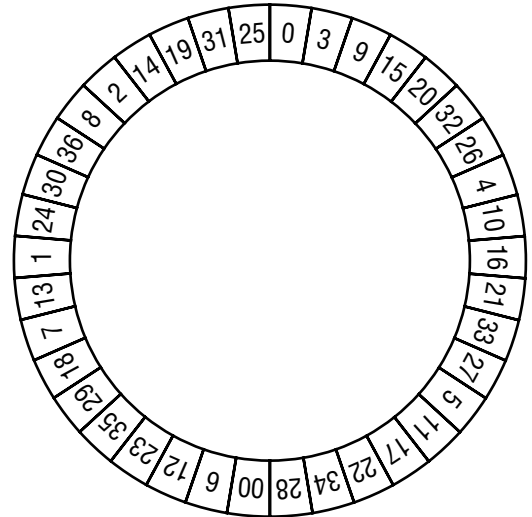

**10-1**

**Enrichment**

6MG2.1

**Angles in Baseball**

Angles play an important part in many sports. In baseball, infielders stand on and cover different parts of the infield depending on the position of the runners. Sometimes, a player will have to turn varying angles to make plays.

For Exercises 1 and 2, look at these pictures of baseball fields. In each one, the four infielders cover different areas of the diamond. Use a protractor to determine the measure of the angle of the area covered by the 2nd baseman with different runner positions.

1.

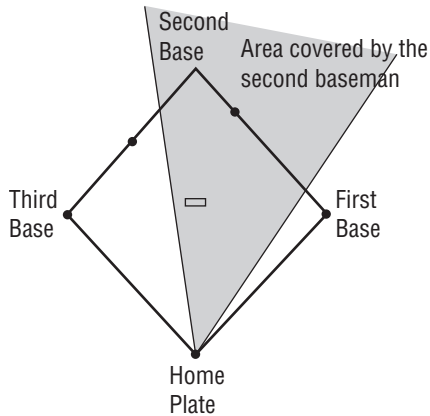

2.

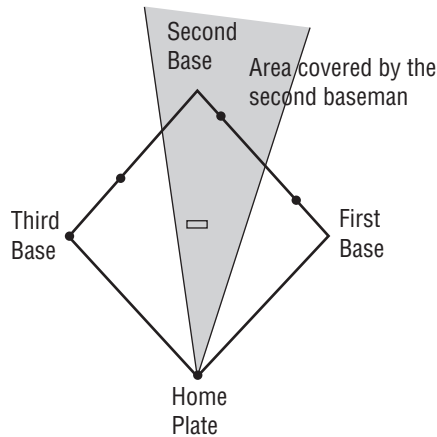

3. The outfield is covered by three other players: the left, center, and right outfielders. The areas they cover may overlap slightly depending on whomever is closest to the ball; but in general, each player has an area to cover. This figure shows the area most often covered by each outfielder. What type of angle does each area make with home plate? What type of angle do all three outfield areas combined create with home plate?

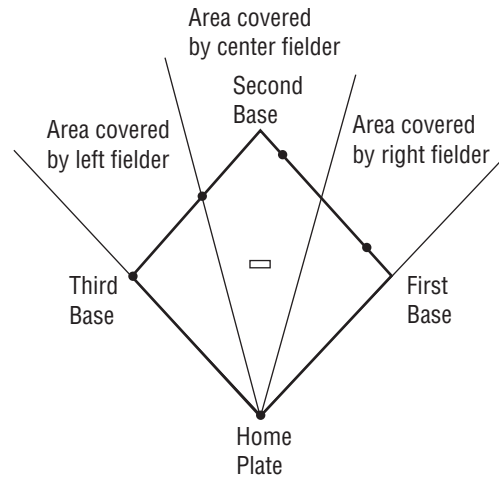

4. During a game, the pitcher notices the runner on second base wants to steal third base. If the pitcher is facing home plate, what type of angle does the pitcher have to turn through to throw the ball to third base?

5. During a different inning, a runner is on first base and appears to want to steal second base. What type of angle does the pitcher need to turn through to throw the ball to second base if the pitcher is facing home plate?

**10-2**

**Enrichment**

6MG2.3

**Matchstick Puzzles**

The puzzles on this page involve a box of wooden matches. Toothpicks or any other straight objects may be also be used.

Use the square figure at the right to make each of the following figures.

1. Move 3 matches to make 3 identical squares.
2. Move 4 matches to make 3 identical squares.
3. Remove 2 matches to make 2 squares.
4. Move 2 matches to make 7 squares. (You may cross the matches in this one only.)

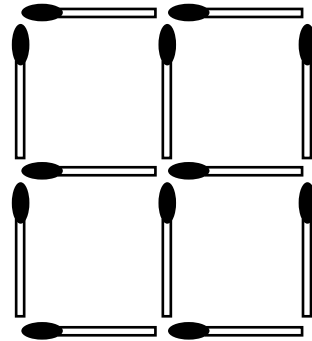

Use the hexagonal figure at the right to make each of the following figures.

5. Move 4 matches to make 3 equilateral triangles.
6. Move 4 matches to make 4 identical diamonds.

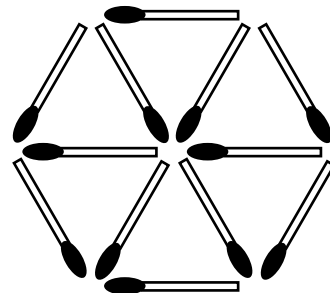

Use the square figure at the right to make each of the following figures.

5. Remove 4 matches to make 5 identical squares.
6. Remove 6 matches to make 5 identical squares.

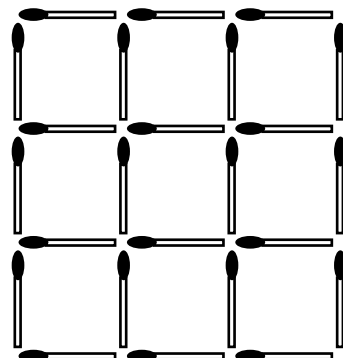

**10-3**

**Enrichment**

5SDAP1.2

**Relative Frequency and Circle Graphs**

The **relative frequency** tells how the frequency of one item compares to the total of all the frequencies. Relative frequencies are written as fractions, decimals, or percents.

For example, in Exercise 1 below, the total of all the frequencies is 50. So, the relative frequency of the grade A is  $8 \div 50$ , or 0.16.

The circle at the right is divided into 20 equal parts. You can trace this circle and then use relative frequencies to make circle graphs.

**Complete each chart to show the relative frequencies. Then sketch a circle graph for the data. Use decimals rounded to the nearest hundredth.**

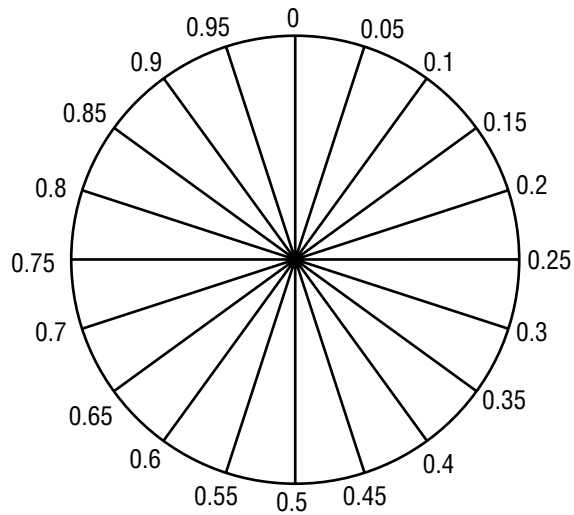

**1. History Grades for 50 Students**

Grade	Frequency	Relative Frequency
A	8	0.16
B	16	
C	18	
D	6	
F	2	

**History Grades for 50 Students**

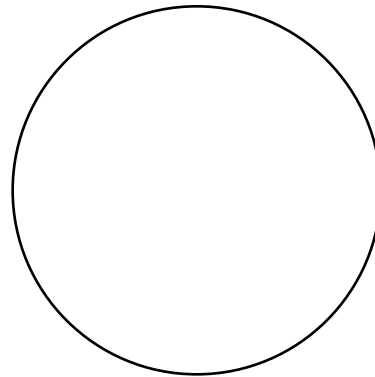

**2. Steve's Budget**

Item	Amount Spent	Relative Spending
Telephone	\$26	
Movies	\$46	
Books	\$24	
Car	\$38	
Other	\$66	

**Steve's Budget**

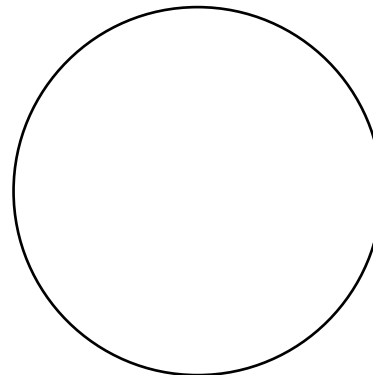

**10-4** **Enrichment****6MG2.2, 6MG2.3****Triangle Sums**

The measures of the angles of a triangle always add up to  $180^\circ$ . The sides of a triangle also have a special relationship. In this activity, you will explore the relationships of the side lengths.

Cut the strips of paper from the right side of this page. Use the 3 specified strips for each problem. Tell if a triangle can be formed with them. If so, tell what type of triangle it is.

1. 6 cm, 14 cm, and 14 cm
2. 6 cm, 6 cm, 14 cm
3. 6 cm, 8 cm, 14 cm
4. 3 cm, 3 cm, 6 cm
5. 3 cm, 6 cm, 8 cm
6. 6 cm, 6 cm, 8 cm
7. Look at your answers above. Choose any set of side lengths that form a triangle. Add the two shortest measures. Compare that sum with the longest side length. Try this with all the triangles above. What conclusion can you make about triangle side lengths?
8. Now look at the sets of side lengths that did not form triangles. Add the two shortest sides. Compare the sum with the length of the third side. What conclusion can you make about three lengths that do not make a triangle?
9. What rule can you give to test any three segment lengths to find out if the segments will form a triangle?

# 10-6

## Enrichment

6MG2.3

### The Colormatch Square

To work this puzzle, cut out the 16 tiles at the bottom of this page. The goal of the puzzle is to create a square so that the sides of any pair of adjacent tiles match. You are not allowed to rotate any of the tiles.

- Complete the solution to the colormatch square puzzle below.

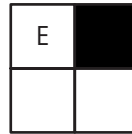
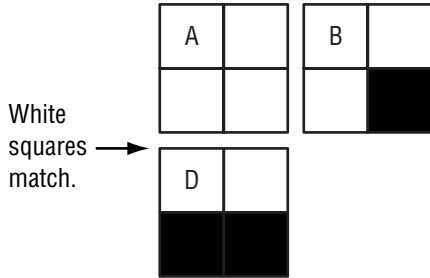

- Find at least one other solution in which the A tile is in the upper left corner.

Copyright © Glencoe/McGraw-Hill, a division of The McGraw-Hill Companies, Inc.

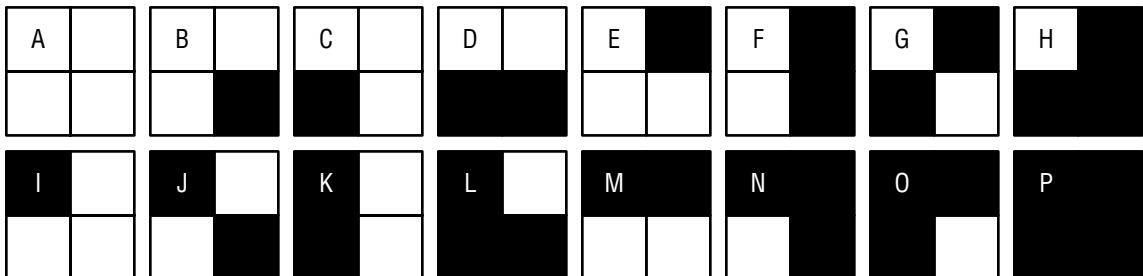

Lesson 10-6

# 10-7

## Enrichment

6NS1.3

### Similar Figures and Areas

The areas of two similar figures are related in a special way. Suppose that rectangle A is 2 units by 3 units and rectangle B is 4 units by 6 units.

The area of rectangle A is  $2 \times 3 = 6 \text{ units}^2$ .  
 The area of rectangle B is  $4 \times 6 = 24 \text{ units}^2$ .

The lengths of the sides of rectangle B are twice those of rectangle A and the area of rectangle B is four times that of rectangle A.

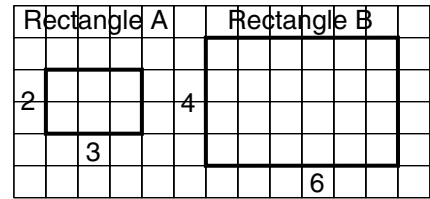

**Sketch figure B similar to figure A and satisfying the given condition.**

1. Rectangle B has sixteen times the area of rectangle A.

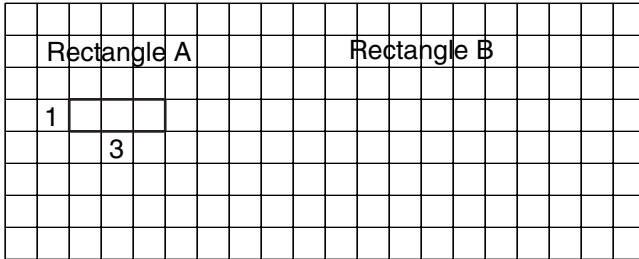

2. Square B has an area that is 4 times that of square A.

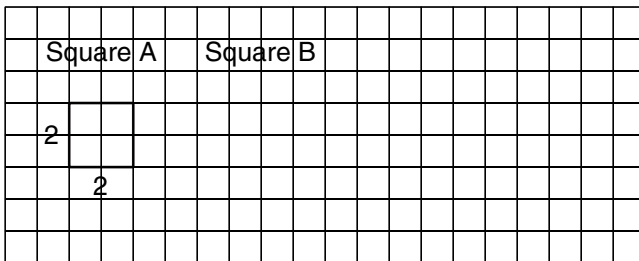

3. Circle B has an area four times that of circle A.

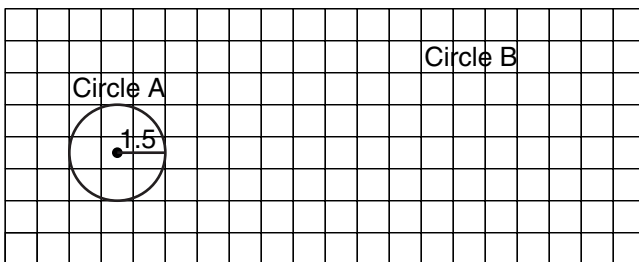



# 10-8

## Enrichment

6MR2.2 , 6AF3.2

### Tessellated Patterns for Solid Shapes

Tessellations made from equilateral triangles can be used to build three-dimensional shapes. In Exercise 1, you should get a shape like the one shown at the right. It is called a pyramid.

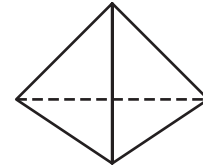

**Copy each pattern. Crease the pattern along the lines. Then follow directions for folding the pattern. Use tape to secure the folded parts. When you have finished each model, describe it in words.**

1. Fold 5 over 1.  
Repeat, in this order:  
fold 6 over 7,  
fold 2 over 6.

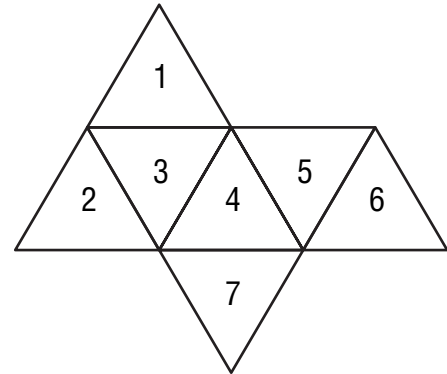

2. Cut between 4 and 5. Then fold 5 over 3.  
Repeat in this order:  
fold 6 over 5,  
fold 7 over 12, and  
fold 2 over 9.

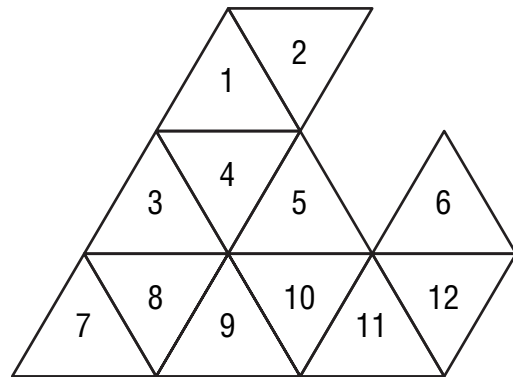

3. Cut between 1 and 2 and between 14 and 15. Then fold 15 over 14.  
Repeat, in this order:  
fold 1 over 2,  
fold 4 over 3,  
fold 11 over 1,  
fold 16 over 5, and  
fold 12 over 13.

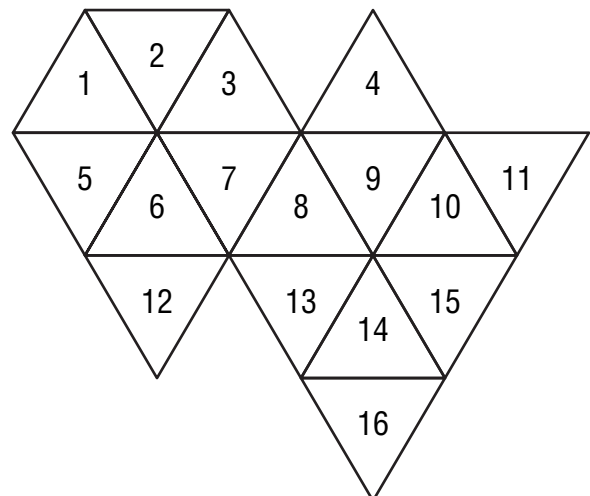

Copyright © Glencoe/McGraw-Hill, a division of The McGraw-Hill Companies, Inc.

Lesson 10-8

**10-9**

**Enrichment**

7MG3.2

**Chess Moves**

In the game of chess, a knight can move several different ways. It can move two spaces vertically or horizontally, then one space at a 90° angle. It can also move one space vertically or horizontally, then two spaces at a 90° angle. Several examples of a knight's moves are indicated on the grid at the right.

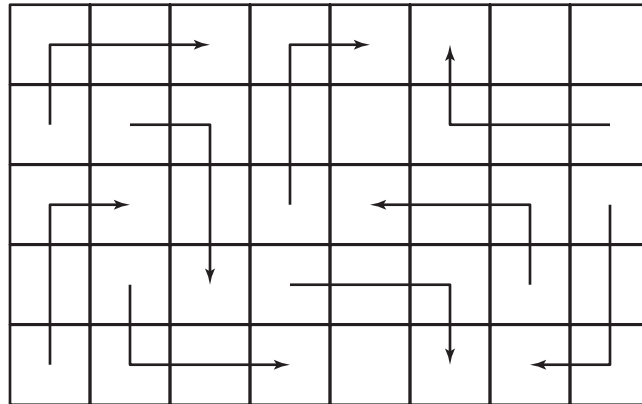

1. Use the diagram at the right. Place a knight or other piece in the square marked 1. Move the knight so that it lands on each of the remaining white squares only once. Mark each square in which the knight lands with 2, then 3, and so on.

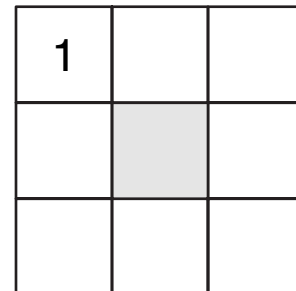

2. Use the diagram below. Place a knight or other piece in the square marked 1. Move the knight so that it lands on each of the remaining squares only once. Mark each square in which the knight lands with 2, then 3, and so on.

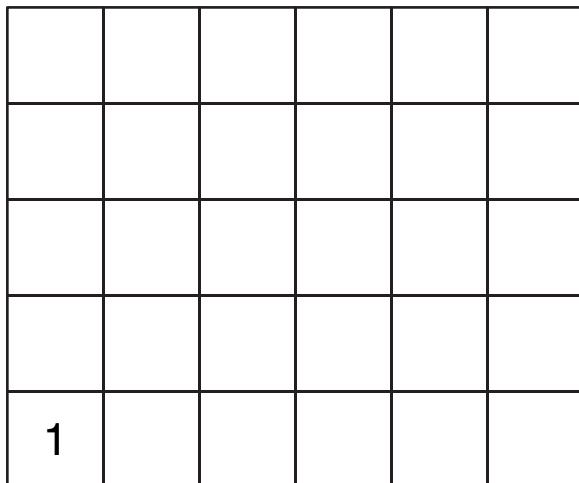

**10-10**

**Enrichment**

7MG3.2

**The Twelve Dot Puzzle**

In this puzzle, a broken line made up of 5 segments must pass through each of 12 dots. The line cannot go through a dot more than once, although it may intersect itself. The line must start at one dot and end at a different dot.

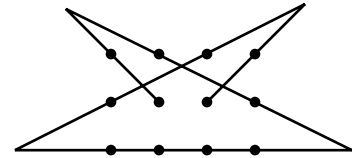

One solution to this puzzle is shown at the right. Two solutions to the puzzle are not “different” if one is just a reflection or rotation of the other.

**Find 18 other solutions.**

1.

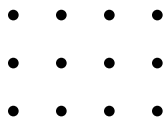

2.

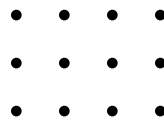

3.

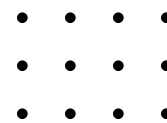

4.

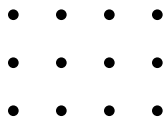

5.

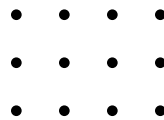

6.

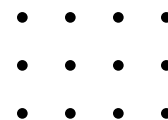

7.

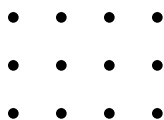

8.

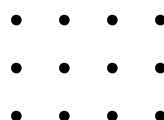

9.

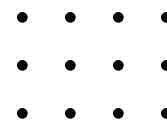

10.

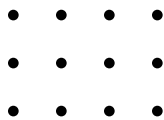

11.

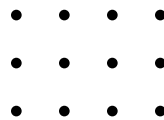

12.

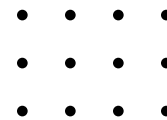

13.

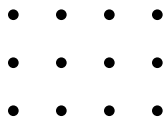

14.

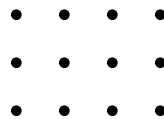

15.

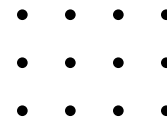

16.

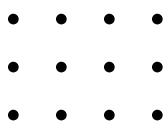

17.

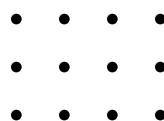

18.

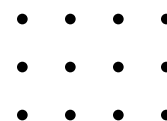

**11-1**

**Enrichment**

**6AF3.1, 6AF3.2**

**Two Area Puzzles**

Cut out the five puzzle pieces at the bottom of this page. Then use them to solve these two puzzles.

1. Use all five puzzle pieces to make a square with an area of 9 square inches. Record your solution below.
2. Use the four largest pieces to make a square with an area of 8 square inches. Record your solution below.

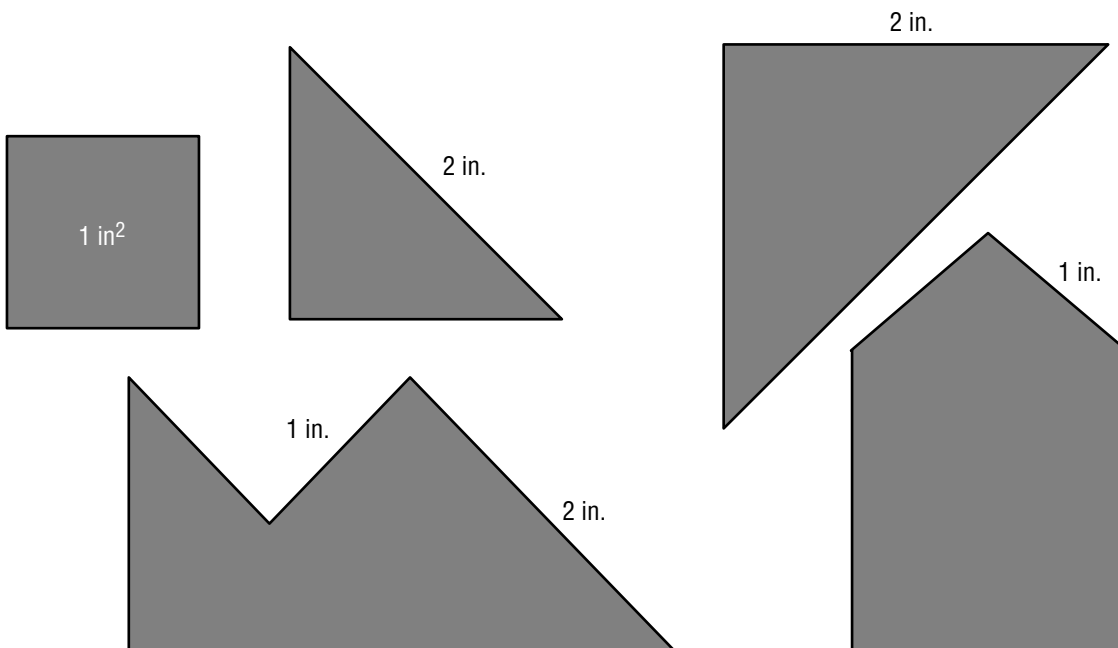
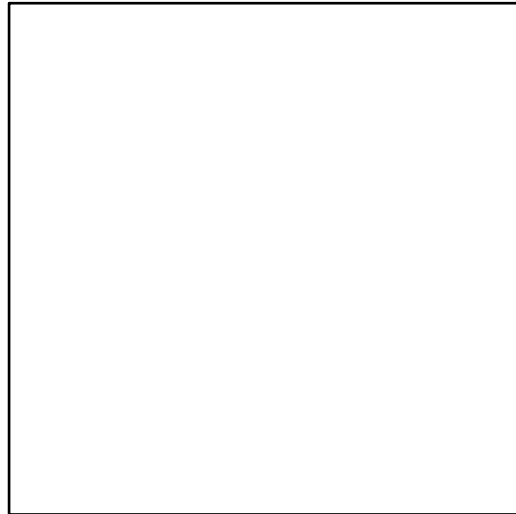
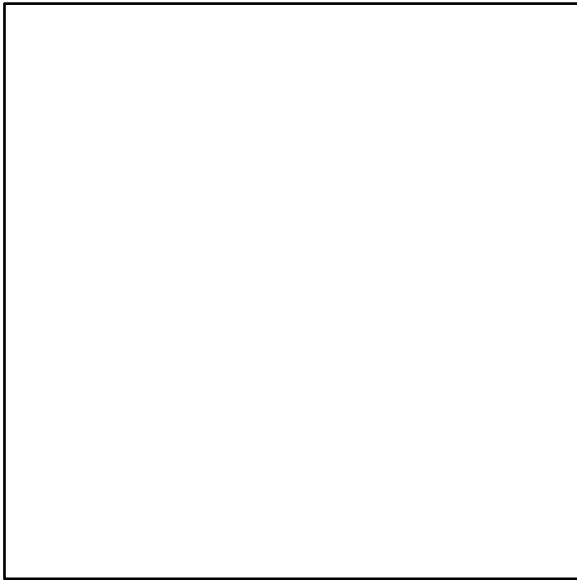

# 11-2

## Enrichment

6AF3.1, 6AF3.2

### Heron's Formula

A formula named after Heron of Alexandria, Egypt, can be used to find the area of a triangle given the lengths of its sides.

**Heron's formula** states that the area  $A$  of a triangle whose sides measure  $a$ ,  $b$ , and  $c$  is given by

$$A = \sqrt{s(s-a)(s-b)(s-c)},$$

where  $s$  is the semiperimeter:

$$s = \frac{a + b + c}{2}.$$

**Estimate the area of each triangle by finding the mean of the inner and outer measures. Then use Heron's Formula to compute a more exact area. Give each answer to the nearest tenth of a square unit.**

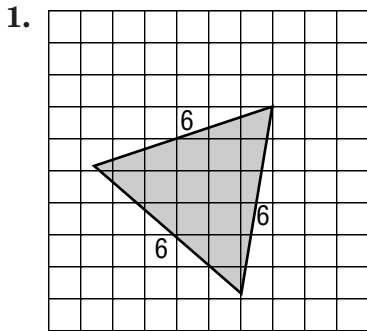

Estimated area:  
Computed area:

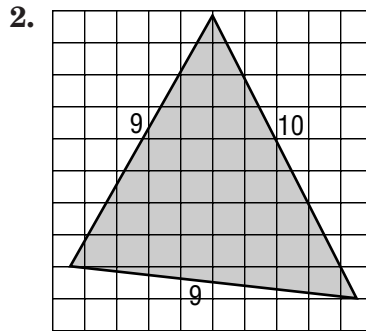

Estimated area:  
Computed area:

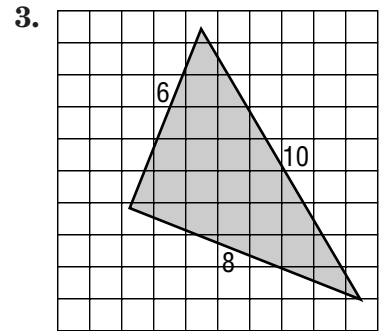

Estimated area:  
Computed area:

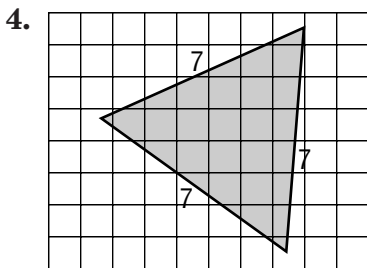

Estimated area:  
Computed area:

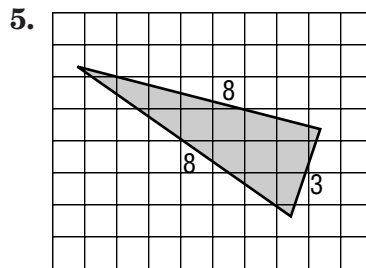

Estimated area:  
Computed area:

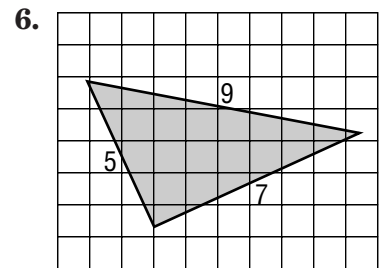

Estimated area:  
Computed area:

Copyright © Glencoe/McGraw-Hill, a division of The McGraw-Hill Companies, Inc.

Lesson 11-2

**11-3** **Enrichment**

6MGI.1, 6MGI.2

**Finding the Length of an Arc**

Recall that the circumference is the measure of the distance around a circle. A portion of the circumference is called an arc. An arc is named by the endpoints of the radii that create it. To find the measure of an arc, you can use a proportion. The ratio of the arc length to the circumference is equal to the ratio of the central angle of the arc to  $360^\circ$ .

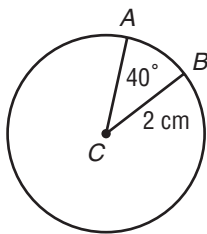

To find the measure of  $\widehat{AB}$ , first set up the ratio.  $\frac{m\widehat{AB}}{2\pi r} = \frac{m\angle ACB}{360^\circ}$

Next, fill in the known values.

$$\frac{m\widehat{AB}}{4\pi} = \frac{40^\circ}{360^\circ}$$

Simplify the fraction.

$$\frac{m\widehat{AB}}{4\pi} = \frac{1}{9}$$

Then solve for  $m\widehat{AB}$ .

$$m\widehat{AB} = \frac{4\pi}{9} \approx 1.40 \text{ cm}$$

**Solve the following problems.**

- A circle has a circumference of 48 centimeters. Find the length of an arc that has a central angle of  $90^\circ$ .  $\frac{m\widehat{AB}}{48} = \frac{90^\circ}{360^\circ}$
- A circle has a circumference of 112 meters. The length of  $\widehat{DF}$  is 14 meters. Find the measure of the central angle of  $\widehat{DF}$ .  $\frac{14}{112} = \frac{x}{360^\circ}$
- A circle has a radius of 5 inches. Find the length of an arc that has a central angle of  $72^\circ$ .  $\frac{m\widehat{AB}}{10\pi} = \frac{72^\circ}{360^\circ}$
- Two arcs in a circle have central angles of  $135^\circ$  and  $45^\circ$ . Find the ratio of the arcs' lengths.  $\frac{135^\circ}{45^\circ}$
- $\widehat{AB}$  has a central angle of  $50^\circ$  in a circle whose diameter is 12 feet, while  $\widehat{DEF}$  has a central angle of  $150^\circ$  in a circle whose diameter is 3 feet. Which of these two arcs is longer? Explain.  $\frac{m\widehat{AB}}{12\pi} = \frac{50^\circ}{360^\circ}$ ,  $\frac{m\widehat{DEF}}{3\pi} = \frac{150^\circ}{360^\circ}$ ,  $\widehat{AB}$

**11-4 Enrichment****6MG1.1, 6MG1.2****Seki Kowa**

Japanese mathematician Seki Kowa (c. 1642–1708) is called The Arithmetical Sage because of his many contributions to the development of mathematics in Japan. Before Seki, mathematics in Japan was considered a form of art to be enjoyed by intellectuals in their leisure time. Seki demonstrated the practical uses of mathematics and introduced social reforms that made it possible for anyone, not just intellectuals, to study mathematics.

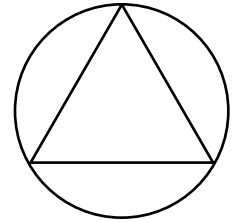

One of Seki's contributions to mathematics was his calculation of a value of  $\pi$  that was correct to eighteen decimal places.

$$\pi \approx 3.141592653589793238\dots$$

Seki had noticed the phenomenon that you see at the right: as the number of sides of a regular polygon increases, the polygon looks more and more like a circle. So, Seki calculated the following ratio for polygons of increasingly many sides.

$$\frac{\text{perimeter of regular polygon}}{\text{diameter of circle drawn around the polygon}}$$

As the number of sides of the polygon gets larger, this ratio must get closer to the ratio of the circumference of the circle to the diameter of the circle. This ratio, of course, is  $\pi$ .

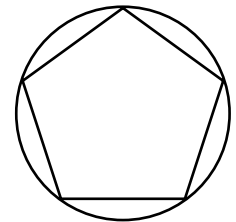
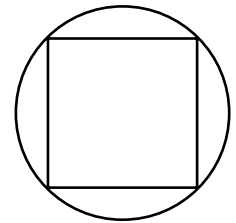

**You are given information below about a regular polygon and the circle drawn around the polygon. Use a calculator to find Seki's ratio. (Give as many decimal places as there are in your calculator display.) What do you notice about your answers?**

1. length of one side = 5  
number of sides = 6  
diameter of circle = 10

2. length of one side  $\approx 4.5922$   
number of sides = 8  
diameter of circle = 12

3. length of one side  $\approx 3.7544$   
number of sides = 20  
diameter of circle = 24

4. length of one side  $\approx 37.5443$   
number of sides = 20  
diameter of circle = 240

5. length of one side  $\approx 1.6754$   
number of sides = 150  
diameter of circle = 80

6. length of one side  $\approx 2.6389$   
number of sides = 500  
diameter of circle = 420

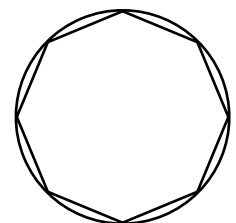
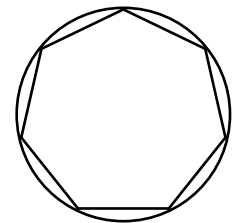
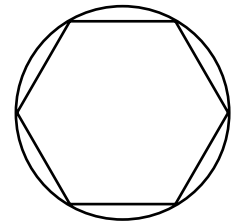

# 11-6

## Enrichment

7MG3.3

### Extending the Pythagorean Theorem

The Pythagorean Theorem says that the sum of the areas of the two smaller squares is equal to the area of the largest square. Show that the Pythagorean Theorem can be extended to include other shapes on the sides of a triangle. To do so, find the areas of the two smaller shapes. Then, check that their sum equals the area of the largest shape.

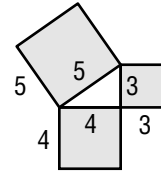

1. area of smallest shape:  
area of middle shape:  
area of largest shape:

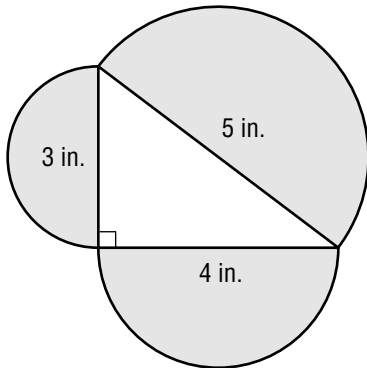

2. area of smallest shape:  
area of middle shape:  
area of largest shape:

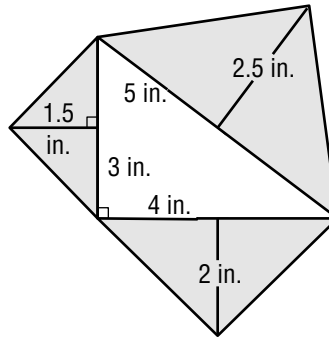

3. area of smallest shape:  
area of middle shape:  
area of largest shape:

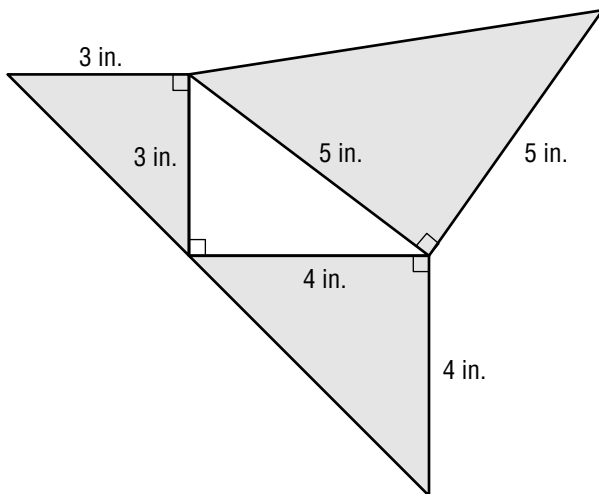

4. area of smallest shape:  
area of middle shape:  
area of largest shape:

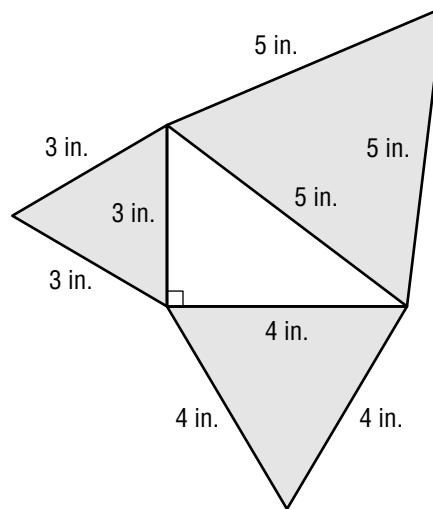

Copyright © Glencoe/McGraw-Hill, a division of The McGraw-Hill Companies, Inc.

Lesson 11-6



**11-7 Enrichment**

7MG3.6

**Properties of Prisms**

Leonard Euler, born in 1707, was one of the world's greatest mathematicians. One of his accomplishments was discovering a formula for calculating the number of faces, edges, and vertices on a three-dimensional figure. He found that  $V + F = E + 2$ . (Vertices + Faces = Edges + 2)

A triangular prism has 6 vertices, 5 faces, and 9 edges. It has the fewest faces, edges, and vertices of any prism.

1. Complete the table for a hexagonal and an octagonal prism.

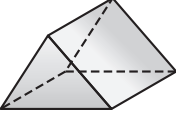
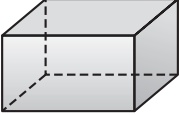
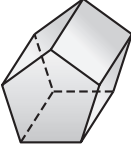
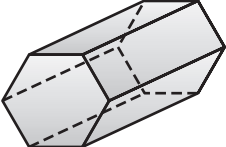
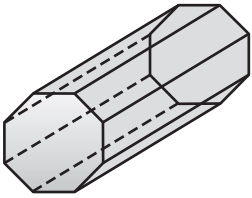
Prism	Vertices	Faces	Edges
triangular 	6	5	9
rectangular 	8	6	12
pentagonal 	10	7	15
hexagonal 			
octagonal 			

2. If a prism has 14 vertices and 21 edges, how many faces does it have? Use Euler's formula.
3. A prism has 20 vertices. How many faces does it have? How many edges?
4. An " $n$ -gonal" prism has two bases, each with  $n$  sides. Use the patterns in the table to write expressions to find the number of faces, edges, and vertices and  $n$ -gonal prism has.

# 11-8

## Enrichment

5MG2.3, 6MR2.4

### Counting Cubes

The figures on this page have been built by gluing cubes together. Use your visual imagination to count the total number of cubes as well as the number of cubes with glue on 1, 2, 3, 4, or 5, or 6 faces.

Complete this chart for the figures below.

Figure	Total Number of Cubes	Number of Faces with Glue on Them					
		1 face	2 faces	3 faces	4 faces	5 faces	6 faces
1							
2							
3							
4							
5							
6							

1.

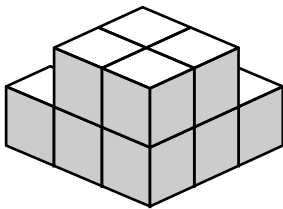

2.

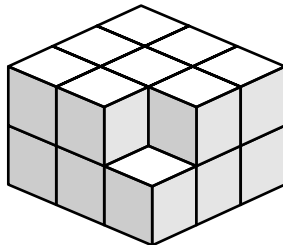

3.

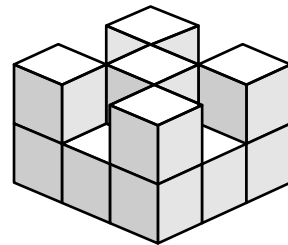

4.

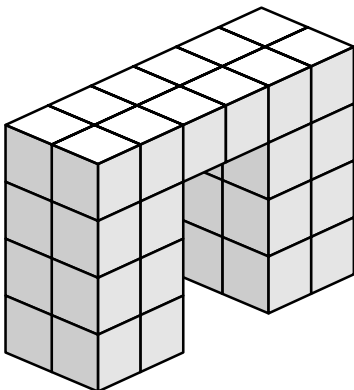

5.

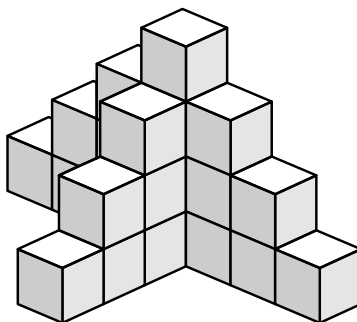

6.

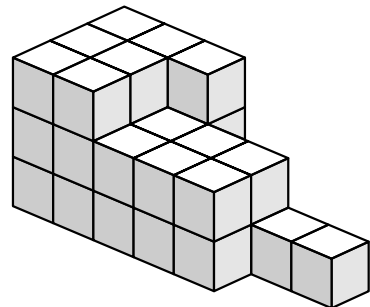

**11-9**

**Enrichment**

**6MG1.3**

**Volumes of Pyramids**

A pyramid and a prism with the same base and height are shown below.

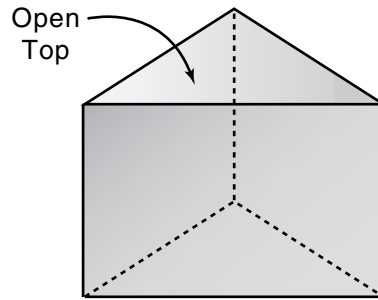
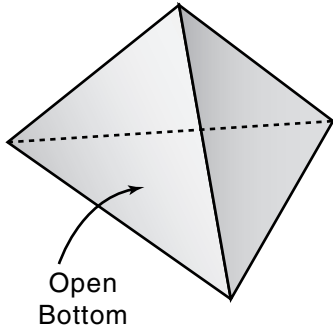

The exercises on this page will help you discover how their volumes are related.

**Enlarge and make copies of the two patterns below to make the open pyramid and the open prism shown above. (Each equilateral triangle should measure 8 centimeters on a side.)**

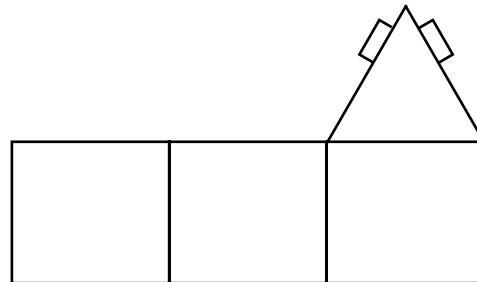
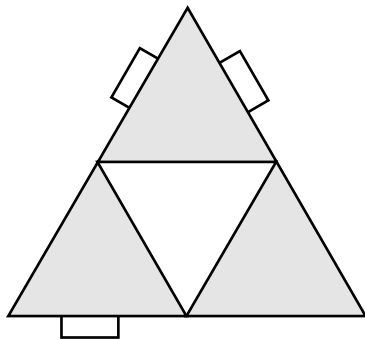

1. Describe the bases of the two solids.
2. How do the heights of the solids compare?
3. Fill the open pyramid with sand or sugar. Pour the contents into the open prism. How many times must you do this to fill the open prism?
4. Describe how you would find the volume of the pyramid shown at the right.

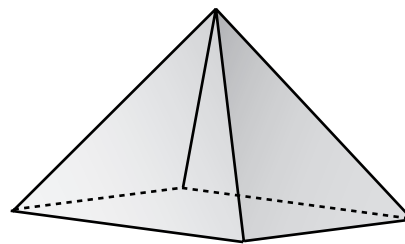

5. Generalize: State a formula for the volume of a pyramid.

# 11-10 Enrichment

6MG1.3

## Volumes of Non-Right Solids

Imagine a stack of ten pennies. By pushing against the stack, you can change its shape as shown at the right. But, the volume of the stack does not change.

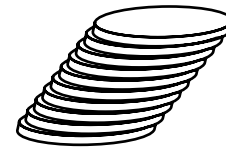
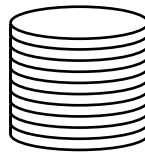

The diagrams below show prisms and cylinders that have the same volume but do not have the same shape.

Right Prism

Non-right Prism

Right Cylinder

Non-right Cylinder

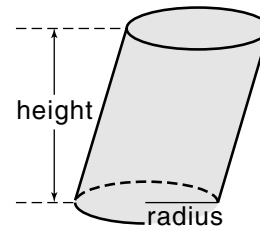
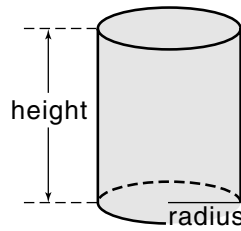
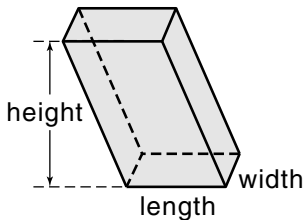
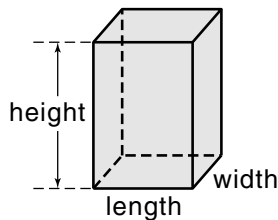

Find the volume of each solid figure. Round to the nearest tenth.

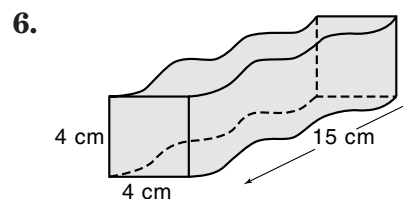
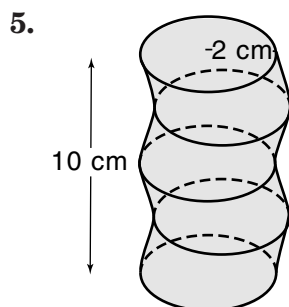
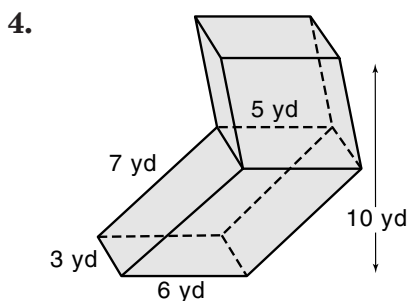
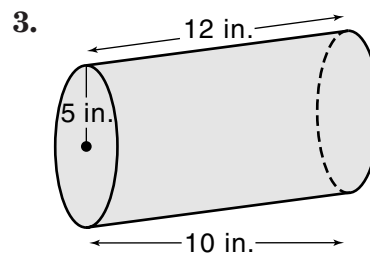
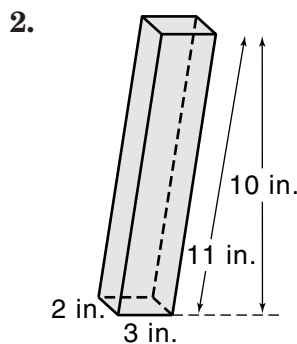
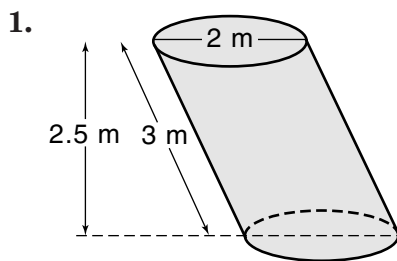

**12-1****Enrichment****7NS2.4****World Series Records**

Each problem gives the name of a famous baseball player. To find who set each record, graph the points on the number line.

**1. pitched 23 strikeouts in one World Series**

$U$  at  $\sqrt{3}$ ,  $X$  at 3.3,  $K$  at 0.75,  $O$  at  $\frac{3}{2}$ ,  $F$  at  $\sqrt{6}$ ,  $A$  at  $2\frac{7}{8}$

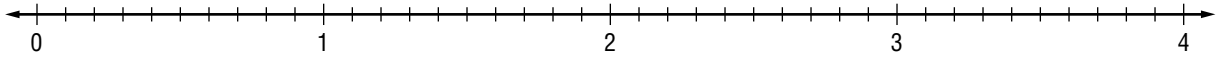
**2. 71 base hits in his appearances in World Series**

$B$  at  $\sqrt{5}$ ,  $R$  at  $\sqrt{12}$ ,  $A$  at 3.75,  $G$  at  $\frac{16}{13}$ ,  $E$  at  $\frac{5}{2}$ ,  $Y$  at 0.375,  $R$  at  $\frac{13}{4}$ ,  $I$  at 1.6, and  $O$  at  $0.\bar{7}$

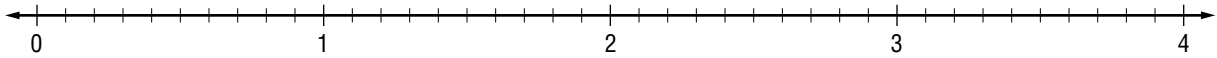
**3. 10 runs in a single World Series**

$N$  at  $\sqrt{60}$ ,  $K$  at  $\sqrt{30}$ ,  $A$  at 4.3,  $S$  at 6.2,  $C$  at  $\frac{46}{9}$ ,  $O$  at  $\sqrt{45}$ , and  $J$  at  $\sqrt{17}$

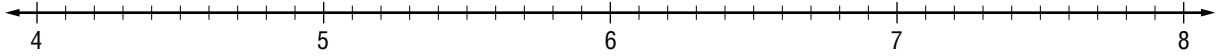
**4. batting average of 0.625 in a single World Series**

$E$  at  $\sqrt{32}$ ,  $U$  at  $6\frac{5}{6}$ ,  $A$  at  $\frac{14}{3}$ ,  $T$  at  $\sqrt{55}$ ,  $B$  at 5.3,  $R$  at  $\sqrt{40}$ ,  $H$  at 7.75,  $B$  at  $\frac{21}{5}$

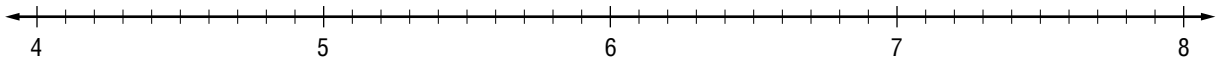
**5. 42 World Series runs in his career**

$E$  at  $\sqrt{140}$ ,  $Y$  at 9.6,  $I$  at 8.6,  $E$  at  $\sqrt{90}$ ,  $A$  at  $\frac{21}{2}$ ,  $M$  at  $\sqrt{70}$ ,  $C$  at  $8\frac{7}{8}$ ,  $M$  at  $\sqrt{100}$ ,  $N$  at 10.7,  $K$  at  $9\frac{1}{11}$ ,  $T$  at  $\sqrt{120}$ ,  $L$  at 11.4

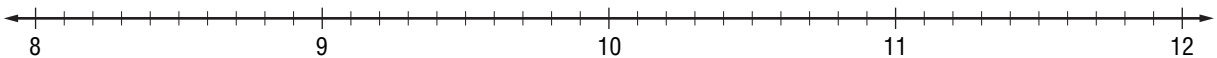

**12-2 Enrichment**

7MG3.3

**Pythagoras in the Air**

In the diagram at the right, an airplane heads north at 180 mi/h. But, the wind is blowing towards the east at 30 mi/h. So, the airplane is really traveling east of north. The middle arrow in the diagram shows the actual direction of the airplane.

The actual speed of the plane can be found using the Pythagorean Theorem.

$$\begin{aligned}\sqrt{30^2 + 180^2} &= \sqrt{900 + 32,400} \\ &= \sqrt{33,300} \\ &\approx 182.5\end{aligned}$$

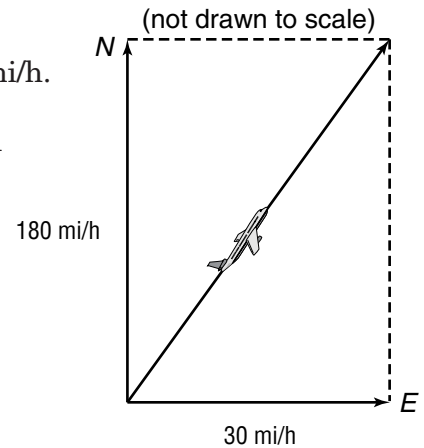

The plane's actual speed is about 182.5 mi/h.

**Find the actual speed of each airplane. Round answers to the nearest tenth. (You might wish to draw a diagram to help you solve the problem.)**

- An airplane travels at 240 mi/h east. A wind is blowing at 20 mi/h toward the south.
- An airplane travels at 620 mi/h west. A wind is blowing at 35 mi/h toward the south.
- An airplane travels at 450 mi/h south. A wind is blowing at 40 mi/h toward the east.
- An airplane travels at 1,200 mi/h east. A wind is blowing at 30 mi/h toward the north.

**12-4 Enrichment**

7MG2.1

**Pattern Puzzles**

1. Make three copies of this pattern. Fold each pattern to make a pyramid. Then, put the three pyramids together to make a cube. Draw a sketch of the completed cube.

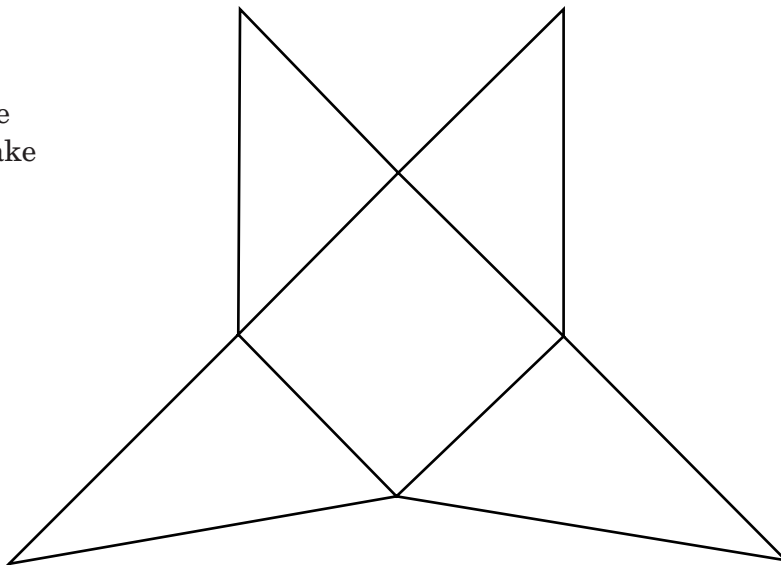

2. Make four copies of this pattern. Fold each pattern to make a solid figure. Then, put the four solids together to make a pyramid. Make a sketch of the finished pyramid.

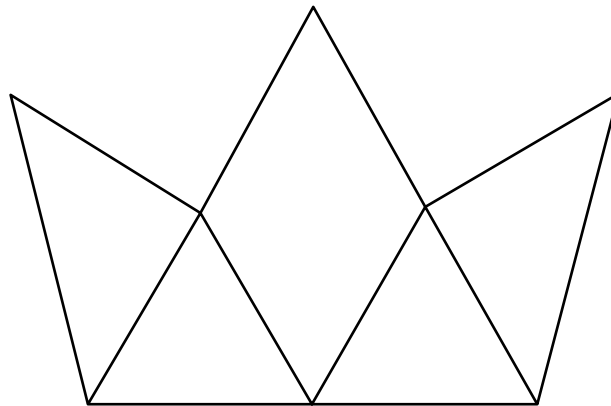

3. Find the surface area of the cube in Exercise 1.

**12-5**

**Enrichment**

7MG2.1

**Cross Sections**

In each diagram on this page, a plane cuts through a solid figure. The intersection of the plane with the solid figure is called a *cross section*.

**Sketch the cross section formed in each diagram.**

1.

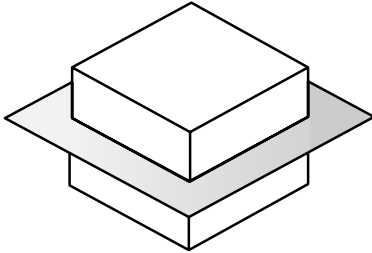

2.

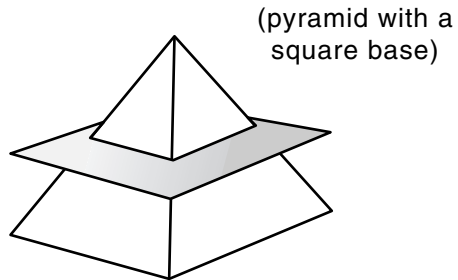

3.

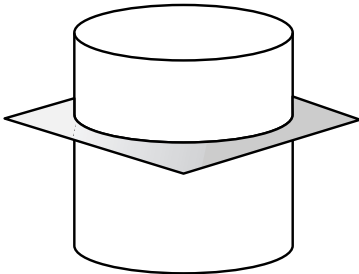

4.

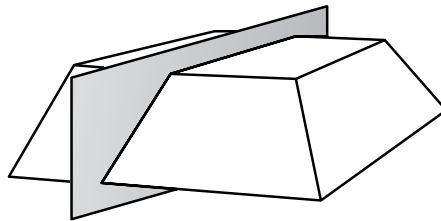

5.

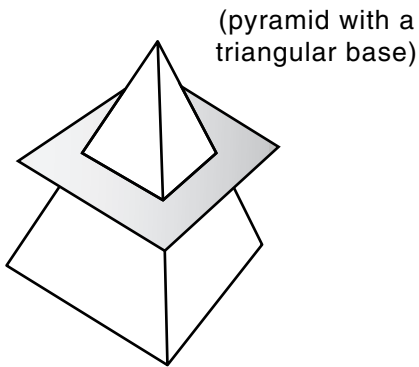

6.

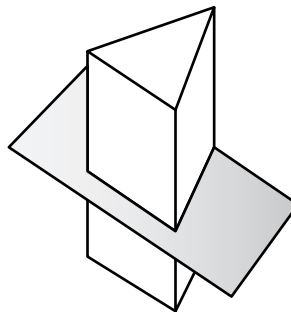

7.

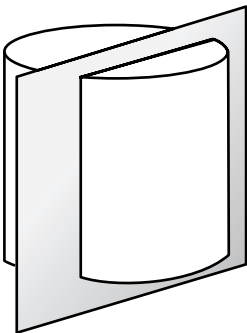

8.

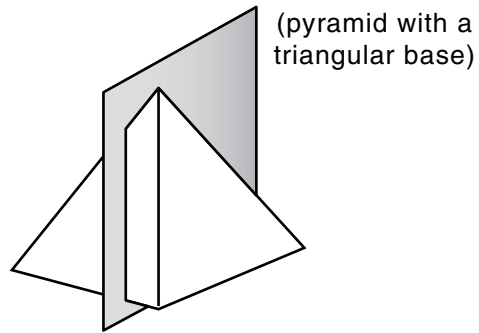

Copyright © Glencoe/McGraw-Hill, a division of The McGraw-Hill Companies, Inc.