



---

## IMPROVEMENT IN THE TRIAC COMMUTATION

---

### INTRODUCTION

In the last few years, the use of triacs has spread to all areas of electronics, including domestic appliances and industrial applications.

The use of triacs has been traditionally limited by their switching behavior in applications where there is a risk of spontaneous firing after conduction.

In order to obtain the required reliability in today's equipment, the designer must take a certain number of precautions: over dimensioning of the device, switching aid networks (snubber), significant margin of security of the junction temperature, etc. This generally involves additional costs.

After a brief discussion of commutation problem when a triac is turned off, this article will describe the progress made in this area and the newest possibilities now offered to triac user thanks to the new series Logic Level and SNUBBERLESS™ triac.

The commutation problem of the triac In its electrical representation the triac can be compared to two thyristors mounted in anti-parallel and coupled with a control device which allows activation of this AC switch with only one gate (see Figure 1a).

In considering the structure of a triac (see Figure 1b), one notices that the conduction zones, corresponding to these two thyristors and which control the current in one direction and then in the other, narrowly overlap each other and the control zone.

During the conduction time, a certain quantity of charges is injected into the structure. The biggest part of these charges disappears by recombining during the fall of the current in the circuit, while another part is extracted at the moment of blocking by the inverse recovery current.

Nonetheless an excess charge remains, particularly in the neighboring regions of the gate, which can provoke in certain cases the firing of the other conduction zone at the moment when the supply voltage of the circuit is reapplied across the triac. This is the problem of commutation.

For a given structure at a determined junction temperature, the switching behavior depends on:

1. The quantity of charges which remains at the moment when the current drops to zero. this number of charges is linked to the value of the current which was circulating in the triac approximately 100 microseconds before the cut-off. (This time corresponds to two or three times the life time of the minority carriers). Thus, the parameter to consider here will be the slope of the decreasing current which is called the commutating  $di/dt$ , or  $(di/dt)_c$ . (see Figure 2)
2. The speed at which the reapplied voltage increases at the moment when the triac turns off, which is called the commutating  $dv/dt$ , or  $(dv/dt)_c$ . (see Figure 2) A capacitive current, proportional to the  $(dv/dt)_c$ , flows into the structure, and therefore injected charges are added to those coming from the previous conduction.

Figure 1. (A) Simplified equivalent schematic of triac circuit; (B) Example of a triac structure

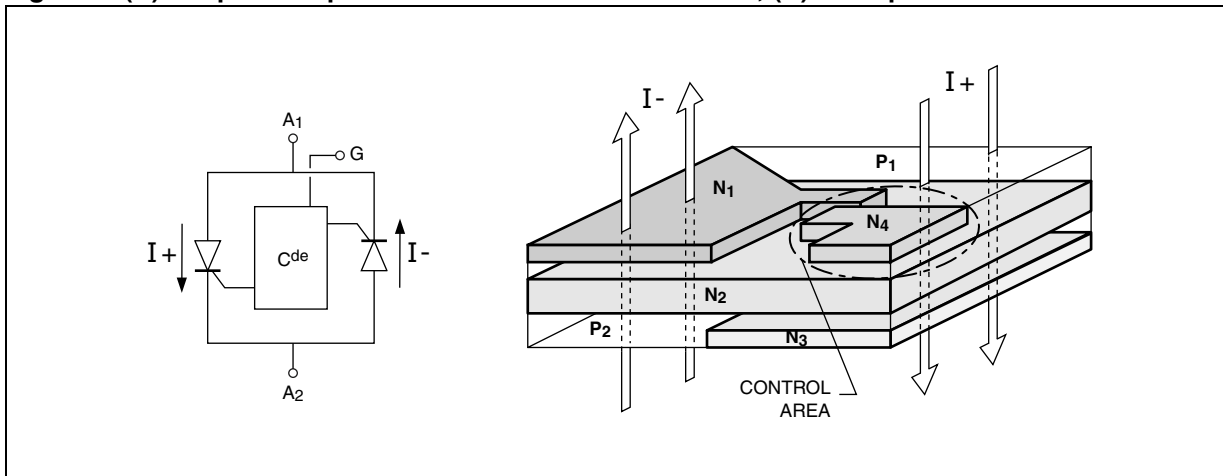

**Characterization**

In order to characterize the switching behavior of a triac when it turns off, we consider a circuit in which we can vary the slope of the decrease in current  $(di/dt)_c$ . In addition, we control the slope of the reapplied voltage by using, for example, a circuit of resistors and capacitors connected across triac to be measured. For a determined  $(dv/dt)_c$ , we progressively increase the  $(di/dt)_c$  until a certain level which provokes the spontaneous firing of the triac. This is the critical  $(di/dt)_c$  value.

Therefore, for different  $(dv/dt)_c$  values, we note the critical  $(di/dt)_c$  value for each sample. This makes possible to trace the curve of the commutation behavior of the triac under consideration.

Figure 3 represents the results obtained with a standard 12A triac ( $I_{GT}$  50mA) and a sensitive gate, 6A triac ( $I_{GT}$  10mA). For standard triacs the critical  $(di/dt)_c$  is slightly modified when we vary the  $(dv/dt)_c$ . For sensitive gate triacs, this parameter noticeably decreases when the slope of the reapplied voltage is increased.

Figure 2. Triac voltage and current at commutation

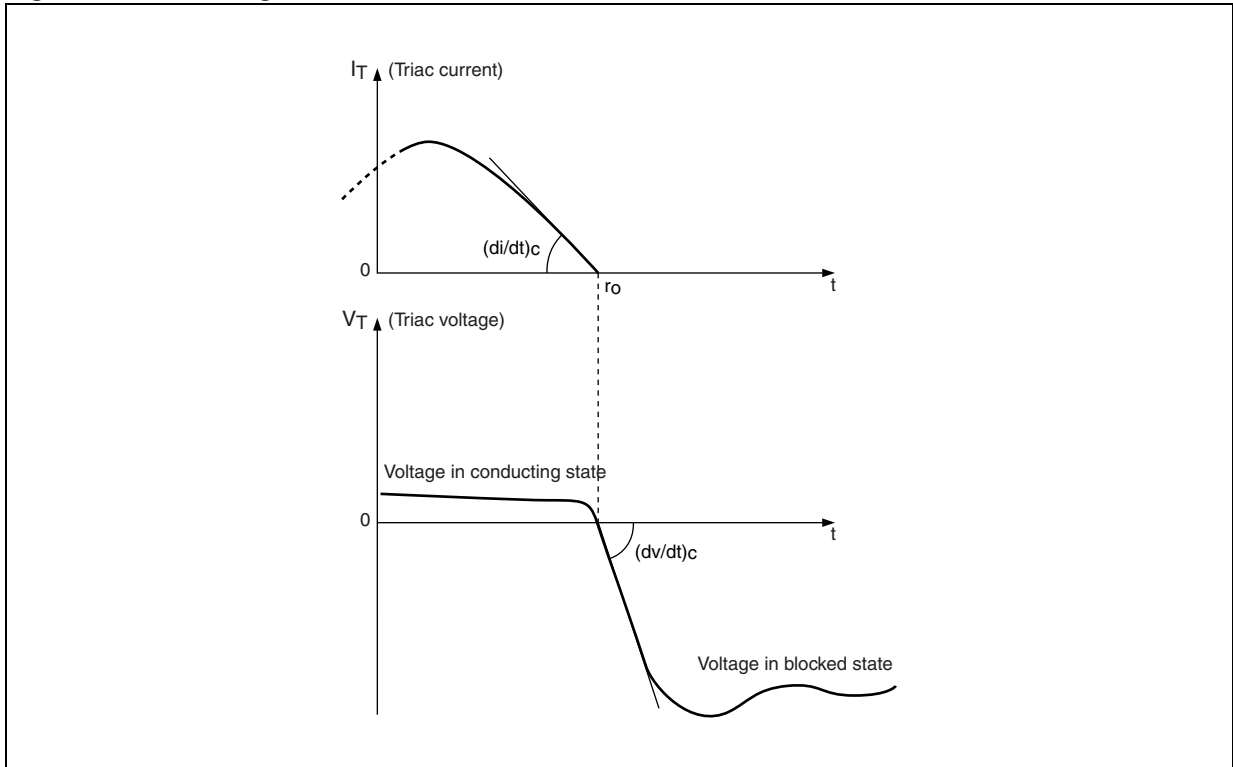
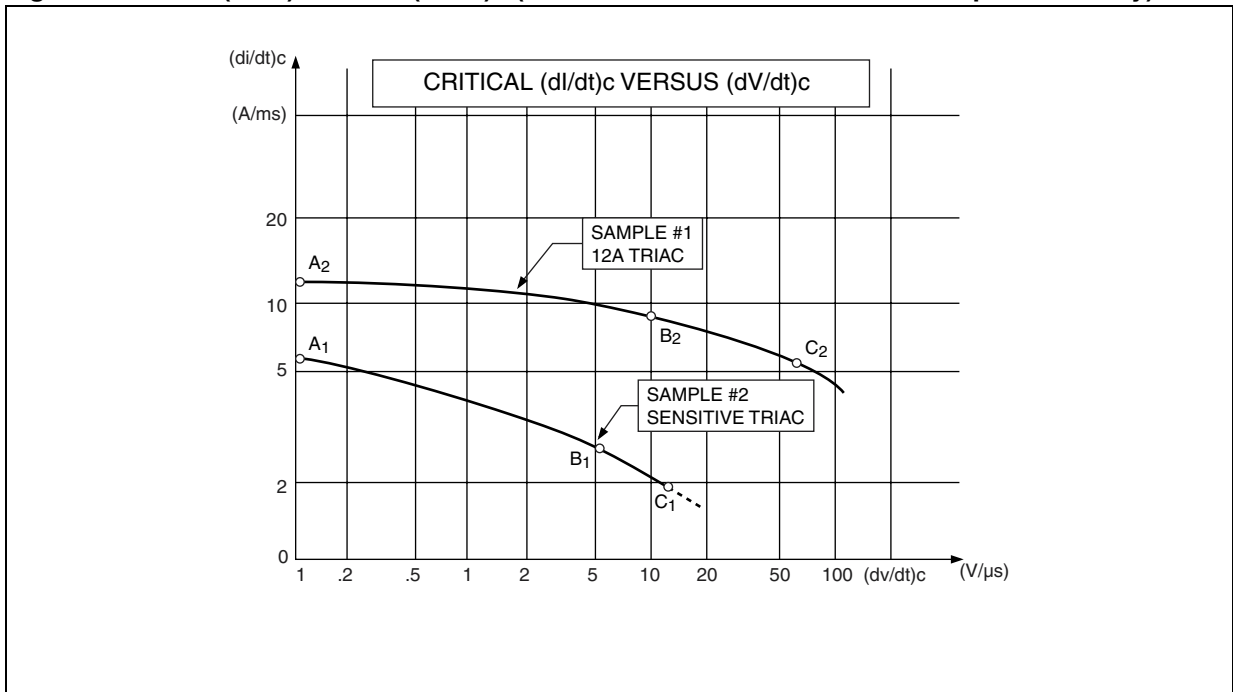

Figure 3. Critical  $(di/dt)_c$  versus  $(dv/dt)_c$  (below the curve the triac turns on spontaneously)



**Note:** A<sub>1</sub> and A<sub>2</sub>: The rate of re-application of the off-state voltage of these points corresponds to the mains (sinusoidal wave form) at zero crossing.  
 B<sub>1</sub> and B<sub>2</sub>: The  $(dv/dt)_c$  is limited by a snubber at the values generally specified in the data sheets (5V/ms or 10V/ms).  
 C<sub>1</sub> and C<sub>2</sub>: These points are obtained without snubber.

## AN439 APPLICATION NOTE

---

In practice, the current waveform, and thus the  $(di/dt)_c$ , is imposed by the circuit. Generally we cannot change it.

So, in triacs applications it is always necessary to know the  $(di/dt)_c$  of the circuit in order to choose a triac with a suitable critical  $(di/dt)_c$ . This is the most important parameter.

Suppose a circuit in which the  $(di/dt)_c$  reaches 15A/ms. The triac n°1 characterized by the upper curve in Figure 3 is not suitable in such a circuit even if the  $(dv/dt)_c$  is reduced nearly to zero by connecting a huge snubber network across it.

### Applications in basic circuits

When considering the constraints in commutation at the turn off of a triac, we can distinguish two cases:

**1. The use of a triac on resistive load (see Figure 5).** In this case the current and the voltage are in phase. When the triac switches off (i.e. when the current drops to zero), the supply voltage is nullified at this instant and will increase across the triac according to the sinusoidal law:

$$V = V_m \sin \omega t$$

Example:

For the European mains of  $V_{rms} = 220V$  at 50Hz, the slope will be:

$$(dv/dt)_c = V_m \times \omega = V_{rms} \times \sqrt{2} \times \omega = \frac{01V}{\mu S}$$

This relatively low  $(dv/dt)_c$  corresponds to points A<sub>1</sub> and A<sub>2</sub> on the curves in Figure 3.

As far as the  $(di/dt)_c$  is concerned in the circuit, it depends on the load. For a resistance of loads R and under a  $V_{rms}$  voltage, we will have:

$$(dv/dt)_c = I_m \times \omega = V_{rms} \times \frac{\sqrt{2}}{R} \times \omega$$

**2. The use of a triac on inductive load.** In this case there is a phase lag between the current and the supply voltage (see Figure 6).

When the currents drops to zero the triac turns off and the voltage is abruptly pushed to its terminals. To limit the speed of the increasing voltage, we generally use a resistive/capacitive network mounted in parallel with the triac. This "snubber" is calculated to limit the  $(dv/dt)_c$  to 5 or 10V/ $\mu$ s according to the specified value in the data sheet. This case corresponds to points B<sub>1</sub> and B<sub>2</sub> in Figure 3. The  $(di/dt)_c$  is also determined in this case by load impedance (z) and the supply voltage.

Figure 4. Current and voltage wave forms for resistive loads: (A) Case On / Off switching; (B) Case of phase control)

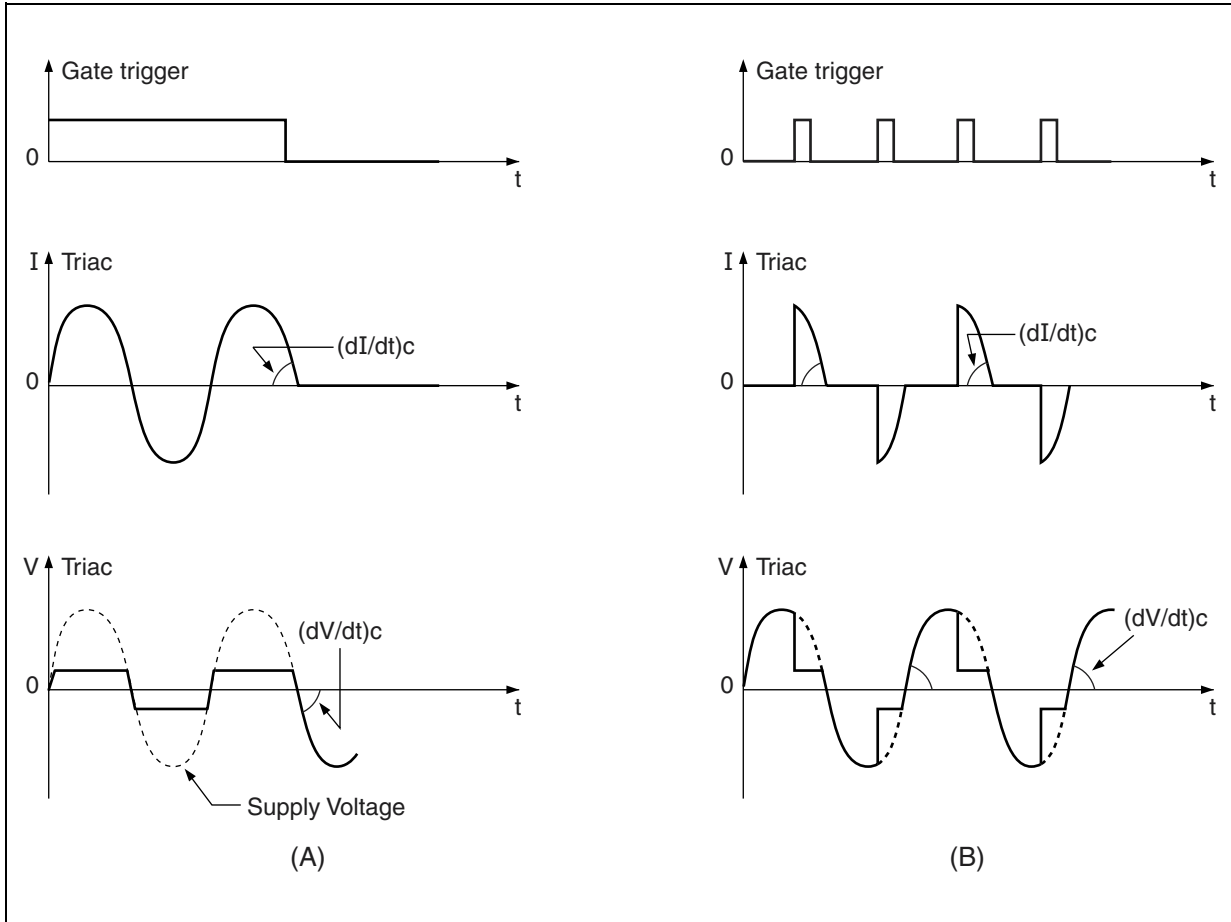
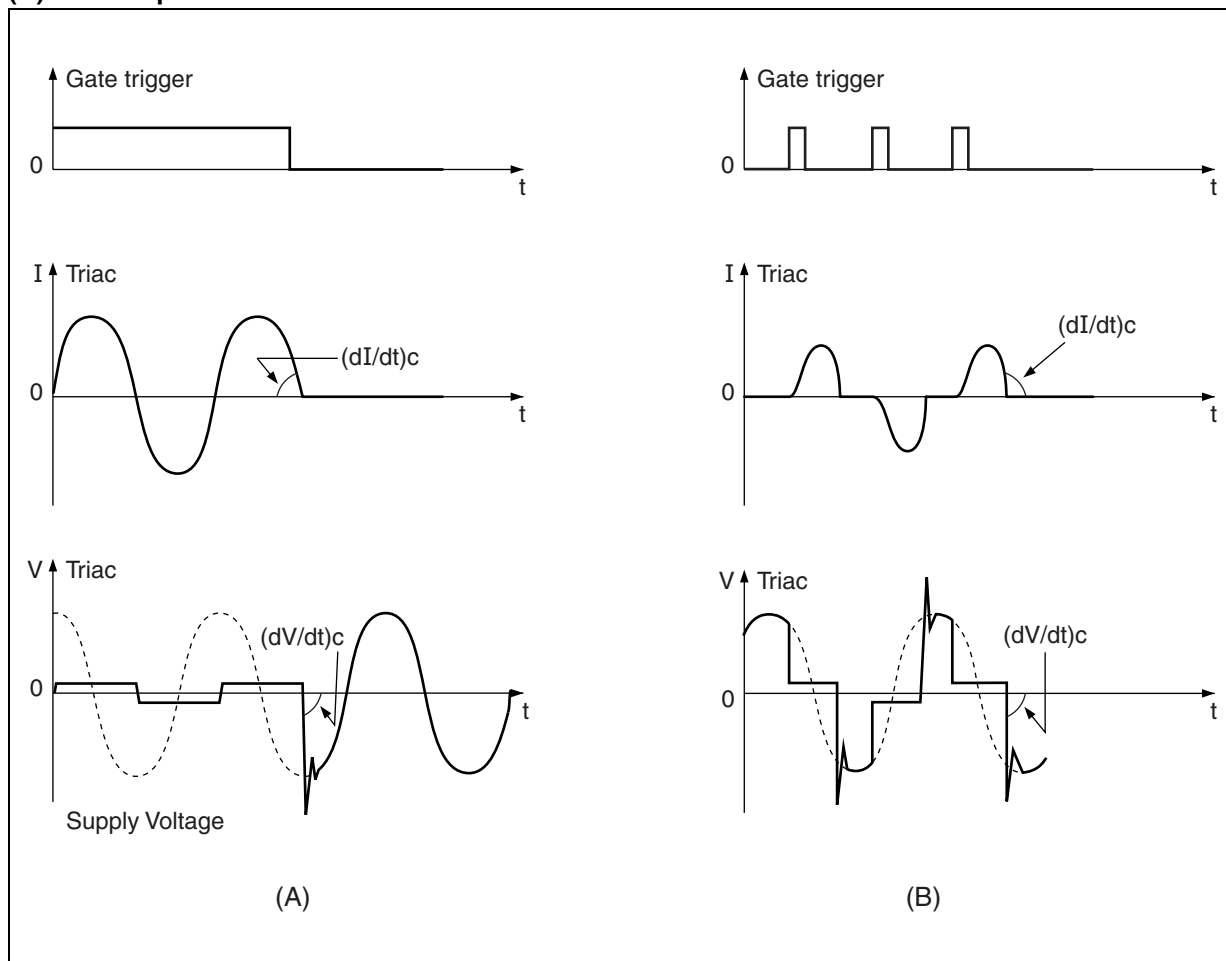

Figure 5. Current and voltage wave forms for inductance loads: (A) Case On / Off switching; (B) Case of phase control



**The use of a triac without a snubber network**

The triac can thus be considered as a switch which turns off at the moment when the current is cut off in the dampened oscillating circuit constituted by the loads L and R and the internal capacity of the triac Ct (see Figure 6). In the case of a pure inductive load, the maximum reapplied (dv/dt)<sub>c</sub> is:

$$\left(\frac{dv}{dt}\right)_c = \sqrt{2 \cdot V_{rms} \cdot I_{rms} \cdot \frac{\omega}{C_t}}$$

For example, the internal capacitance of a 12A triac is about 70pF. Therefore, on inductive load, the maximum (dv/dt)<sub>c</sub> without snubber will be limited to 50 or 100 V/S according to the characteristics of the load. It is interesting to know the behavior of the triac, in particular the critical (di/dt)<sub>c</sub> value, in these conditions. This characterization corresponds to the points C<sub>1</sub> and C<sub>2</sub> of the curve Figure 3.

Figure 6. Triac commutation on an inductance load without a snubber network

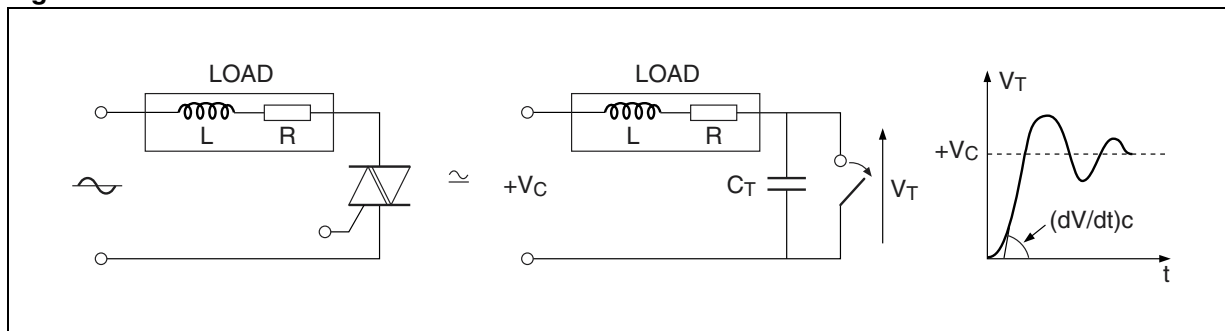

### A PROGRESS: THE NEW TECHNOLOGY

To make significant progress in the triac area is to essentially improve the commutative behavior at the turn off of the triac. In other words the critical  $(di/dt)_c$  has to be improved.

In order to reach this goal, a new structure has been developed. In this structure, the different active zones have been de-coupled to the maximum in such a way as to separate the elementary thyristors and the gate area. This is made possible by sacrificing the gate triggering in the fourth quadrant. In practice this does not pose a problem because the gate drive circuits of a triac generally use two of the third first quadrants (see Figure 7).

Figure 7. Triac commutation on an inductance load without a snubber network

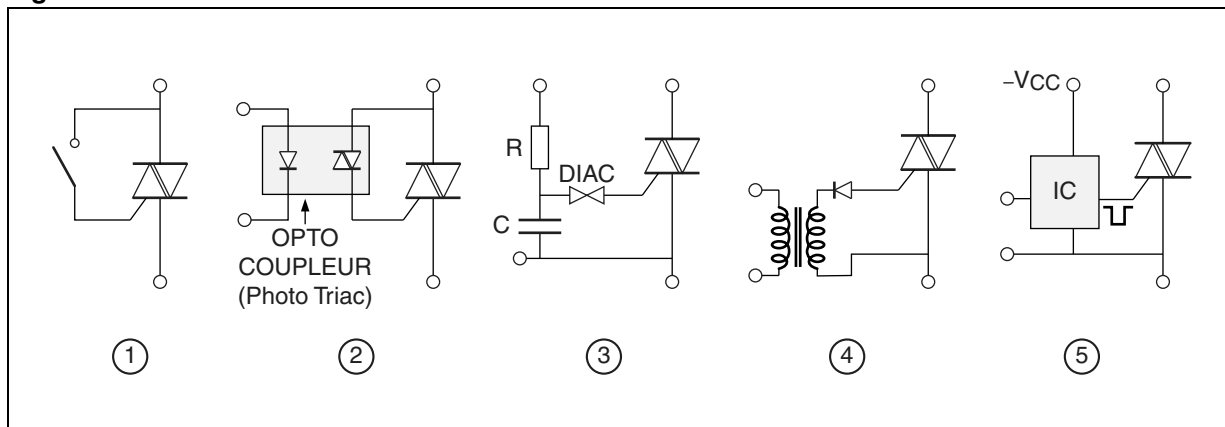

For a given technology, the commutative behavior of triacs depends on the sensitivity of the gate. The correlation between the critical  $(di/dt)_c$  and the gate current for 12A triacs is represented in Figure 8. In the same chart, we can see the results obtained with conventional triacs versus the new technology triacs. As can be seen, the progress that has been made at this level is significant.

The performances and specifications

Figure 8. Correlation between commutative behavior and sensitivity. (Measurements performed on several lots of 12A triacs)

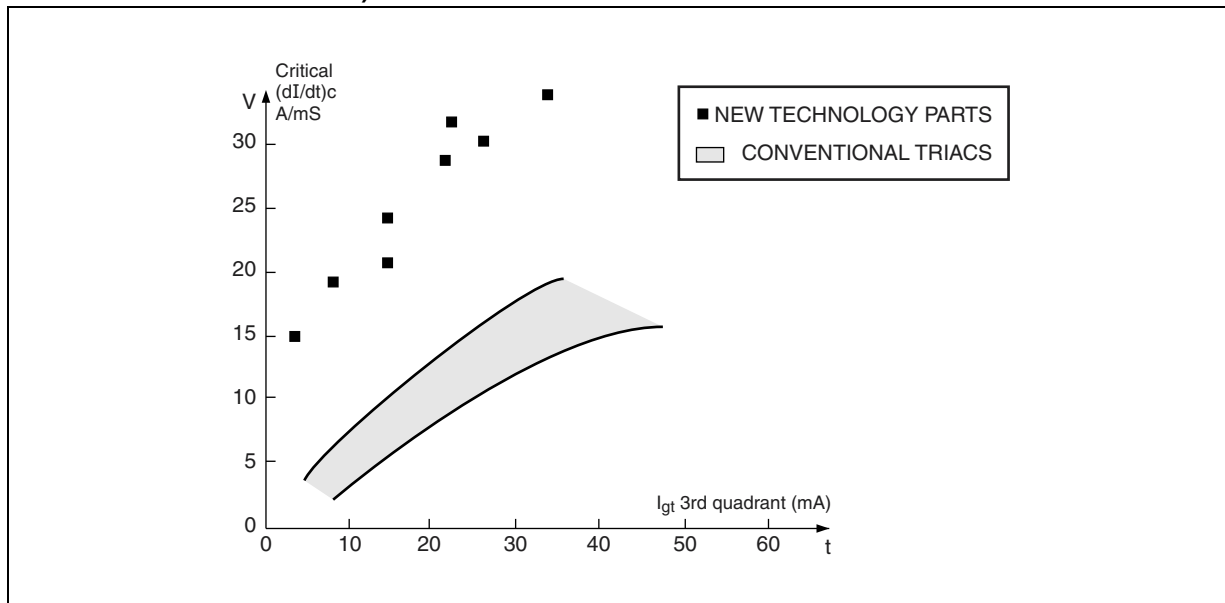

The new technology has been put into place with the manufacturing of the two new series, Logic Level and SNUBBERLESS Triacs. In the data sheets of these new triacs a critical  $(di/dt)_c$  limit is specified at the maximum junction temperature ( $T_j$  max).

Logic Level triacs

In this category we consider sensitive triacs in which the maximum gate current ( $I_{GT}$ ) is 5mA for the TW type and 10mA for the SW one.

In the data sheets of the Logic Level triacs a minimum  $(di/dt)_c$  is specified for the following cases:

- Resistive load with a  $(dv/dt)_c$  of 0.1V/ $\mu$ s.
- Inductive load with a  $(dv/dt)_c$  of 20V/ $\mu$ s

For example the 6A triac is specified as follows:

Table 1. Triac specifications

Symbol	Test conditions		Quadrant		Suffix		Unit
					TW	SW	
$t_{GT}$	$V_D = V_{DRM}$ ; $I_G = 90mA$ ; $dI_G/dt = 0.8A/ms$	$T_j = 25^\circ C$	I - II - III	Typ	2	2	$\mu s$
$(di/dt)_c$ <sup>1</sup>	$dV/dt = 0.1V/ms$	$T_j = 110^\circ C$		Min	3.5	4.5	A/ms
	$dV/dt = 20V/ms$			Min	1.8	3.5	

Note: 1. For either polarity of electrode  $A_2$  voltage with reference to electrode  $A_1$ .

SNUBBERLESS Triacs

This series of triacs presently covers the range 6 to 25A with gate currents of 35mA (CW type) and 50mA (BW type) according to the type required. This series has been specially designed so that the triacs switches from the on state to the off state without the use of an external snubber circuit.



Whatever the nature of the load, there is absolutely no risk of spurious firing at the turn off of the triac as long as it is functioning under the specified  $(di/dt)_c$  value.

The SNUBBERLESS triacs are specified at critical  $(di/dt)_c$  values which are greater than the decreasing slope of the nominal current in a sinusoidal configuration. For example, the slope of the current in a triac conducting 16A when the current drops to zero is:

$$\left(\frac{di}{dt}\right)_c = I_{rms} \times \sqrt{2} \times \omega = 7A/ms \text{ at } 50Hz$$

The BTA/BTB16-600BW is specified at  $(di/dt)_c = 14A/ms$ .

Table 2 summarizes the characteristics of the BW, CW SNUBBERLESS triacs which are presently available:

**Table 2. Characteristics of the BW, CW SNUBBERLESS triacs presently available**

						WITHOUT SNUBBER
Type	Current	Voltage	Suffix	IGT Max (mA)	Static dV/dt Min (V/μs)	$(di/dt)_c$ Min (A/ms)
BTA / BTB	06A	200 to 800V	BW	50	500	5
			CW	35	250	3.5
BTA / BTB	08A	200 to 800V	BW	50	500	7
			CW	35	250	4.5
BTA / BTB	10A	200 to 800V	BW	50	500	9
			CW	35	250	5.5
BTA / BTB	12A	200 to 800V	BW	50	500	12
			CW	35	250	6.5
BTA / BTB	16A	200 to 800V	BW	50	500	14
			CW	35	250	8.5
BTA / BTB	20A	200 to 800V	BW	50	500	18
			CW	35	250	11
BTB	24A	200 to 800V	BW	50	500	22
			CW	35	250	13
BTA	26A	200 to 800V	BW	50	500	22
			CW	35	250	13

## THE ADVANTAGES AND APPLICATIONS

### Logic Level

The goal of these triacs is to be controlled directly by logic circuits and microcontrollers like the ST6 series: Outputs of ST6 can sink currents up to 20mA per I/O line, and therefore drive TW and SW.

These triacs are ideal interface for power components supplied by 110 or 220V, such as valves, heating resistances, and small motors.

The specification of the critical  $(di/dt)_c$  value on both resistive and inductive loads allows one

1. to know the margin of security of the circuit in relation to the risk of the spurious firing, which results in improved reliability, and
2. to optimize the performance of the triac to be used, which results in a cost reduction.

Figure 9. Triac commutation on an inductance load without a snubber network

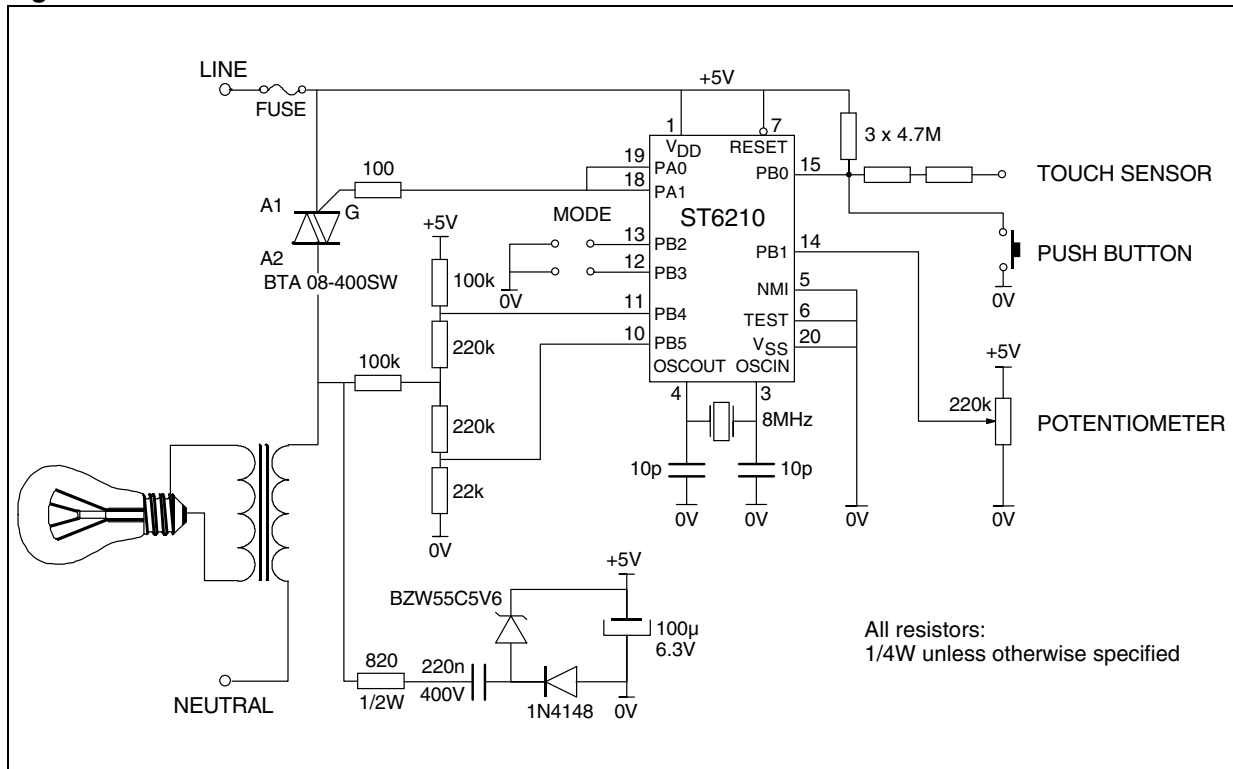

### SNUBBERLESS Triacs

The commutation of SNUBBERLESS triacs is specified without a limitation (dv/dt)<sub>c</sub>. With the suppression of the snubber in the circuit, there is a noticeable cost reduction.

Each SNUBBERLESS triac series is specified with a critical (di/dt)<sub>c</sub> value and the static (dv/dt) at the highest possible level, taking into consideration the gate sensitivity (I<sub>GT</sub>). The minimum specified levels for these two parameters allows the use of these products in circuits where there is a need for high safety factor, such as:

**Static relays in which the load is not well defined.** With conventional triacs it is difficult to adapt the snubber to all possible cases.

SNUBBERLESS triacs resolve this problem (see Figure 10).

**Motor drive circuits.** Figure 11 shows an inversion circuit of an asynchronous motor where spurious firing of the triac, normally assumed to be in off-state, must be absolutely be avoided.

The critical (di/dt)<sub>c</sub> of SNUBBERLESS triacs is greater than the slope of the nominal current of the specific type under consideration. This is important for several applications, including:

Circuits in which the (di/dt)<sub>c</sub> in a transient state is greater than in the steady state. This is the case for universal motors controlled by AC phase control circuit. Table 3 shows how to the use of a SNUBBERLESS triac can optimize the efficiency of the circuit.

Circuits which generate wave forms with a very high (di/dt)<sub>c</sub>, such as inductive load supplied by a diode bridge (see Figure 12). It is only limited by the parasitic inductance of the AC circuit.

Figure 10. Solid state relay diagram

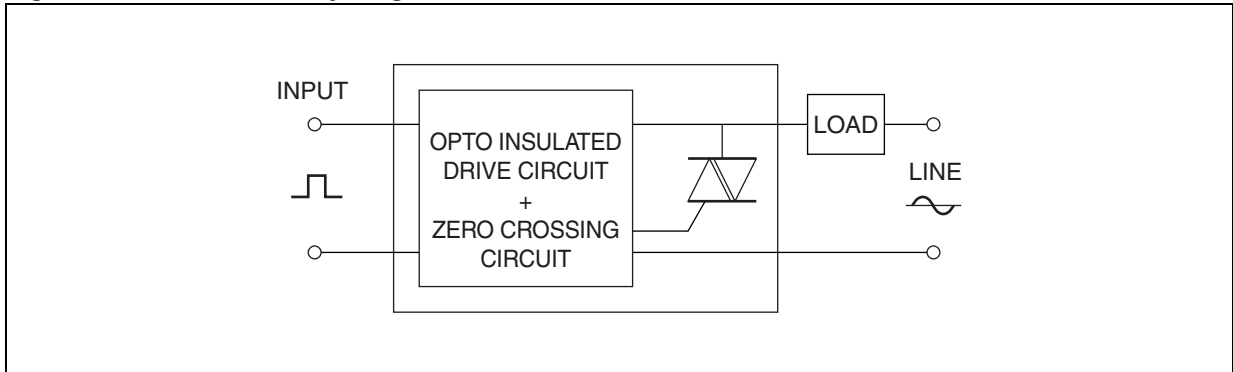

Figure 11. Triac commutation on an inductance load without a snubber network

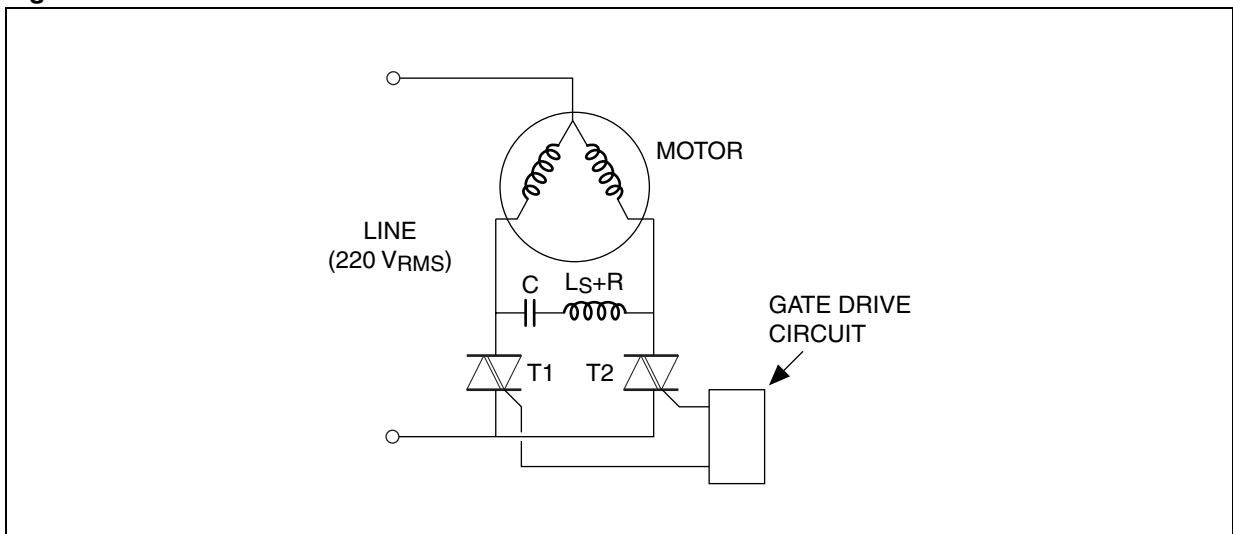
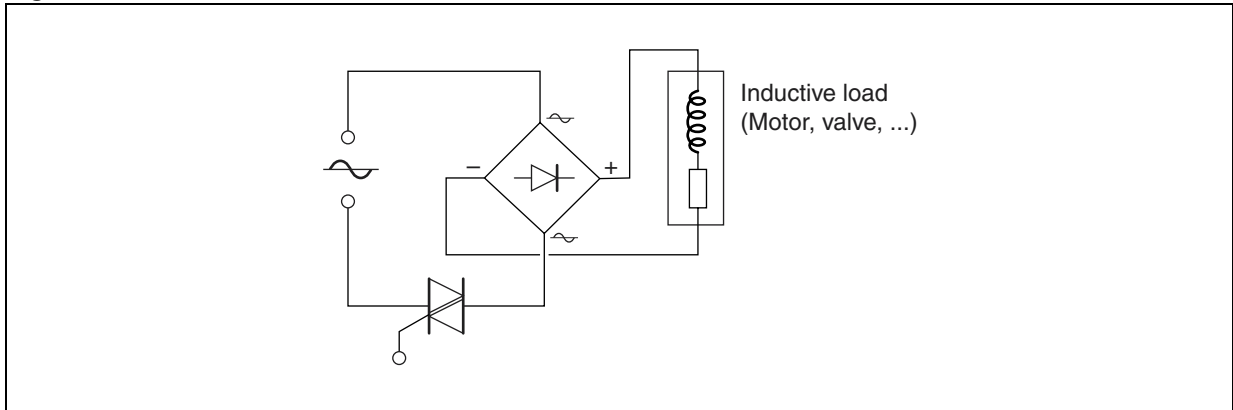

Table 3. Universal motor control: Triac choice must comply with maximum (di/dt)c  
(For example, a SNUBBERLESS 10A triac is sufficient to control a 110V AC 600 W motor)

Power	Supply Voltage	Nominal Current	Max Current to Control	Triac Range	(di/dt)c Max <sup>(1)</sup>	Standards Triac	SNUBBERLESS Triac
600 W	220V/50Hz 110V/60Hz	3 ARMS 6 ARMS	3.5 A 7 A	6 A 10 A	A A/ms 7 A/ms	BTA10-600B BTA16-400B <sup>(2)</sup>	BTA06-600BW BTA10-400BW
1200 W	220V/50Hz 110V/60Hz	6 ARMS 12 ARMS	7 A 14 A	10 A 16 A	7 A/ms 15 A/ms	BTA16-600B BTB24-400B	BTA10-600BW BTA20-600BW

Note: 1. Maximum transient (di/dt)c. This parameter depends very much on the type of the motor.  
2. This type specified at 7A/ms minimum can be too small certain applications could need 25 A standard triac.

**Figure 12. Triac commutation on an inductance load without a snubber network**



### CONCLUSION

Thanks to the recent progress made in triac technology, the designer now has at disposal devices with a commutating behavior which is compatible with all applications in the 50 or 60Hz range. This includes phase control and static commutation for loads going from a few watts to several kilowatts.

The capability of this new generation of triacs allows:

1. To increase the reliability of circuits, particularly where there is a risk of spontaneous firing even in the most difficult configurations.
2. To reduce the cost by using sensitive gate, LOGIC LEVEL triacs without the need for an interface between the gate and the logic circuit, or utilizing SNUBBERLESS triacs which are specified without a resistive/capacitive network.

Additionally, the limit of the  $(di/dt)_c$  parameter is now listed in ST data sheets.

This permits the optimization of the circuit by specifying stricter guidelines in the choice of the component.

**REVISION HISTORY****Table 4. Revision History**

<b>Date</b>	<b>Revision</b>	<b>Description of Changes</b>
May-1992	1	First Issue
19-Apr-2004	2	Stylesheet update. No content change.

Information furnished is believed to be accurate and reliable. However, STMicroelectronics assumes no responsibility for the consequences of use of such information nor for any infringement of patents or other rights of third parties which may result from its use. No license is granted by implication or otherwise under any patent or patent rights of STMicroelectronics. Specifications mentioned in this publication are subject to change without notice. This publication supersedes and replaces all information previously supplied. STMicroelectronics products are not authorized for use as critical components in life support devices or systems without express written approval of STMicroelectronics.

The ST logo is a registered trademark of STMicroelectronics.  
All other names are the property of their respective owners

© 2004 STMicroelectronics - All rights reserved

STMicroelectronics GROUP OF COMPANIES

Australia - Belgium - Brazil - Canada - China - Czech Republic - Finland - France - Germany - Hong Kong - India - Israel - Italy - Japan -  
Malaysia - Malta - Morocco - Singapore - Spain - Sweden - Switzerland - United Kingdom - United States

[www.st.com](http://www.st.com)