



32-Tap FleaPoT™, 2-Wire Digital Potentiometers

MAX5460/MAX5463/MAX5466/MAX5467/MAX5468

General Description

The MAX5460/MAX5463/MAX5466/MAX5467/MAX5468 linear-taper digital potentiometers perform the same function as a mechanical potentiometer or a variable resistor. These devices consist of a fixed resistor and a wiper contact with 32 tap points that are digitally controlled through a 2-wire serial interface.

The MAX5468 is configured as a potentiometer. The rest of the devices in this family are configured as variable resistors. See *Pin Configurations* for part functionality.

Three resistance values are available: 10kΩ (MAX5466/MAX5467/MAX5468), 50kΩ (MAX5463), and 100kΩ (MAX5460). The MAX5460/MAX5463 (100kΩ and 50kΩ) are available in a space-saving 5-pin SC70 package. The MAX5466/MAX5467/MAX5468 (10kΩ) are available in 5-pin and 6-pin SOT23 packages.

Applications

- LCD Screen Adjustment
- Volume Control
- Mechanical Potentiometer Replacement
- Gain Adjustment
- Line Impedance Matching

Features

- ◆ Miniature SC70 and SOT23 Packages
- ◆ 0.3µA Ultra-Low Supply Current
- ◆ +2.7V to +5.5V Single-Supply Operation
- ◆ Glitchless Switching Between Resistor Taps
- ◆ Power-On Reset to Midscale
- ◆ 2-Wire Up/Down Serial Interface
- ◆ 10kΩ, 50kΩ, and 100kΩ Resistance Values

Ordering Information

PART	TEMP. RANGE	PIN-PACKAGE	TOP MARK	R (kΩ)
MAX5460EXK	-40°C to +85°C	5 SC70	ACA	100
MAX5463EXK	-40°C to +85°C	5 SC70	ACB	50
MAX5466EUK	-40°C to +85°C	5 SOT23	ADQQ	10
MAX5467EUT	-40°C to +85°C	6 SOT23	AARH	10
MAX5468EUT	-40°C to +85°C	6 SOT23	AARI	10

FleaPoT is a trademark of Maxim Integrated Products.

Functional Diagram appears at end of data sheet.

Pin Configurations

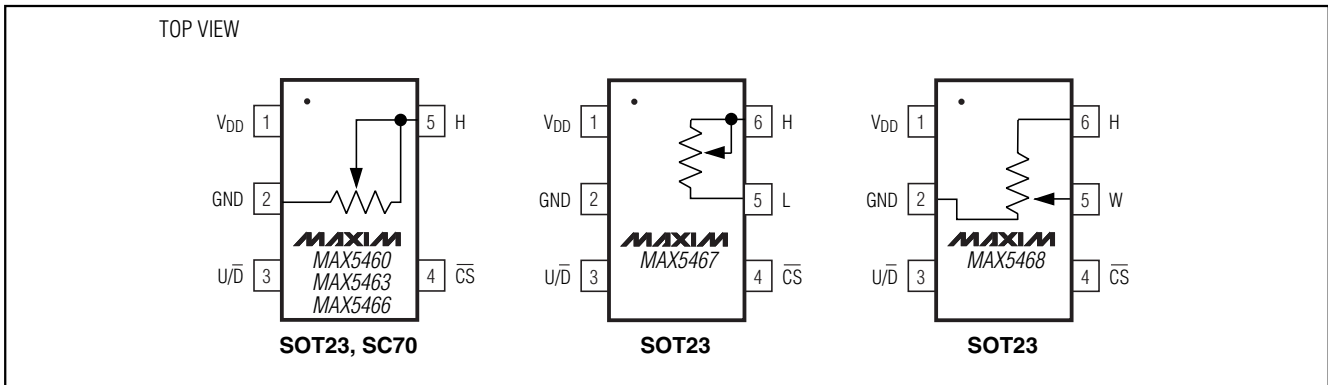

32-Tap FleaPoT™, 2-Wire Digital Potentiometers

ABSOLUTE MAXIMUM RATINGS

V_{DD} to GND	-0.3V to +6V	Continuous Power Dissipation ($T_A = +70^\circ\text{C}$)
\overline{CS} and U/\overline{D} to GND		5-pin SC70 (derate 3.1mW/°C above $T_A = +70^\circ\text{C}$).....
(MAX5460/63/66/67/68).....	-0.3V to ($V_{DD} + 0.3$)V	5-pin SOT23 (derate 7.1mW/°C above $T_A = +70^\circ\text{C}$).....
Input and Output Latch-Up Immunity	$\pm 200\text{mA}$	6-pin SOT23(derate 8.7mW/°C above $T_A = +70^\circ\text{C}$).....
Maximum Continuous Current into H, L, and W		Operating Temperature Range
MAX5460 (100k Ω)	$\pm 0.6\text{mA}$	Junction Temperature
MAX5463 (50k Ω)	$\pm 1.3\text{mA}$	Storage Temperature Range
MAX5466/MAX5467/MAX5468 (10k Ω)	$\pm 1.3\text{mA}$	Soldering Temperature (soldering, 10s).....

Stresses beyond those listed under "Absolute Maximum Ratings" may cause permanent damage to the device. These are stress ratings only, and functional operation of the device at these or any other conditions beyond those indicated in the operational sections of the specifications is not implied. Exposure to absolute maximum rating conditions for extended periods may affect device reliability.

ELECTRICAL CHARACTERISTICS

($V_{DD} = +2.7\text{V}$ to $+5.5\text{V}$, $V_H = V_{DD}$, $V_L = 0$, $T_A = -40^\circ\text{C}$ to $+85^\circ\text{C}$. Typical values are at $V_{DD} = +2.7\text{V}$, $T_A = +25^\circ\text{C}$, unless otherwise noted.)

PARAMETER	SYMBOL	CONDITIONS	MIN	TYP	MAX	UNITS
DC PERFORMANCE						
Resolution			32			Taps
End-to-End Resistance		MAX5460	75	100	125	k Ω
		MAX5463	37.5	50	62.5	
		MAX5466/MAX5467/MAX5468	7.5	10	12.5	
End-to-End Resistance Tempco	TC_R		35			ppm/°C
Ratiometric Resistance Tempco			5			ppm/°C
Integral Nonlinearity	INL		± 0.5			LSB
Differential Nonlinearity	DNL		± 1			LSB
Full-Scale Error			± 0.1			LSB
Zero-Scale Error			1			LSB
Wiper Resistance	R_W	MAX5460/MAX5463	600		1200	Ω
		MAX5466/MAX5467/MAX5468	160		240	
DIGITAL INPUTS						
Input High Voltage	V_{IH}		$0.7 \times V_{DD}$			V
Input Low Voltage	V_{IL}		$0.3 \times V_{DD}$			V
TIMING CHARACTERISTICS (Figures 1, 2)						
U/\overline{D} Mode to \overline{CS} Setup	t_{CU}		25			ns
\overline{CS} to U/\overline{D} Step Setup	t_{CI}		50			ns
\overline{CS} to U/\overline{D} Step Hold	t_{IC}		25			ns
U/\overline{D} Step Low Period	t_{iL}		25			ns
U/\overline{D} Step High Period	t_{iH}		25			ns
Up/Down Toggle Rate (Note 1)	f_{TOGGLE}		1			MHz
Output Settling time (Note 2)	t_{SETTLE}	100k Ω variable resistor configuration, $C_L = 10\text{pF}$	1			μs
		100k Ω potentiometer configuration, $C_L = 10\text{pF}$	0.25			

32-Tap FleaPoT™, 2-Wire Digital Potentiometers

MAX5460/MAX5463/MAX5466/MAX5467/MAX5468

ELECTRICAL CHARACTERISTICS (continued)

($V_{DD} = +2.7V$ to $+5.5V$, $V_H = V_{DD}$, $V_L = 0$, $T_A = -40^{\circ}C$ to $+85^{\circ}C$. Typical values are at $V_{DD} = +2.7V$, $T_A = +25^{\circ}C$, unless otherwise noted.)

PARAMETER	SYMBOL	CONDITIONS	MIN	TYP	MAX	UNITS
POWER SUPPLIES						
Supply Voltage	V_{DD}		2.7		5.5	V
Active Supply Current (Note 3)	I_{DD}				25	μA
Standby Supply Current (Note 4)	I_{SD}	$V_{DD} = +5V$		0.3	1	μA

Note 1: Up/Down Toggle Rate:

$$f_{TOGGLE} = \frac{1}{t_{SETTLE}}$$

Note 2: Typical settling times are dependent on end-to-end resistance.

Note 3: Supply current taken while changing wiper tap, $f_{TOGGLE} = 1MHz$.

Note 4: Supply current taken while wiper position is fixed.

Typical Operating Characteristics

($T_A = +25^{\circ}C$, unless otherwise noted.)

WIPER RESISTANCE vs. WIPER VOLTAGE (MAX5460/MAX5463)

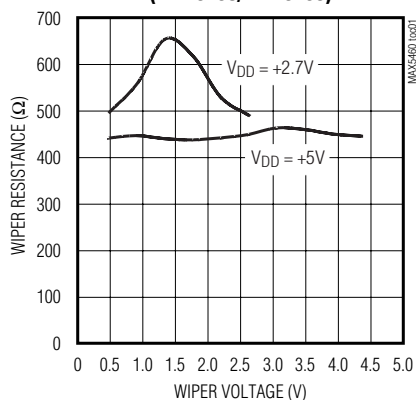

WIPER RESISTANCE vs. WIPER VOLTAGE (MAX5466/MAX5467/MAX5468)

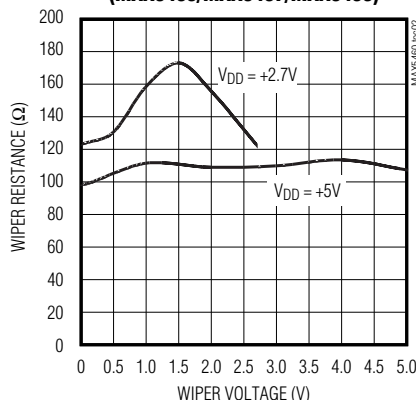

END-TO-END RESISTANCE % CHANGE vs. TEMPERATURE

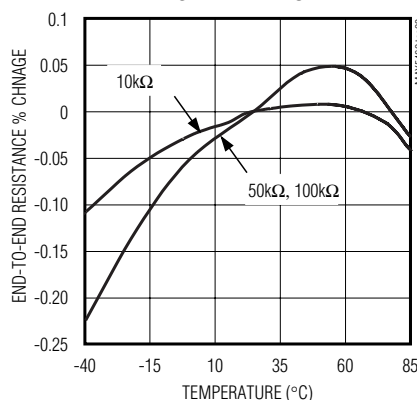

END-TO-END RESISTANCE vs. TAP POSITION

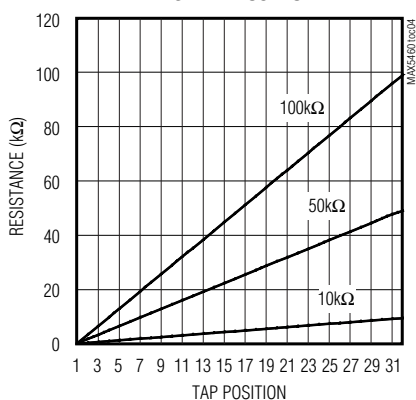

SUPPLY CURRENT vs. TEMPERATURE

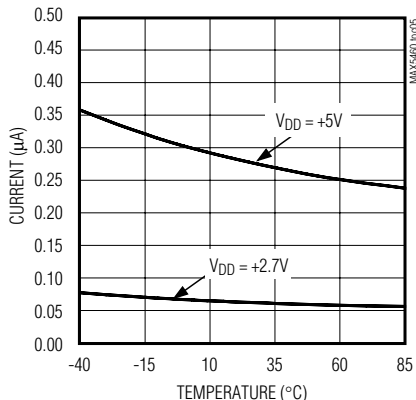

TAP-TO-TAP SWITCHING TRANSIENT (MAX5460)

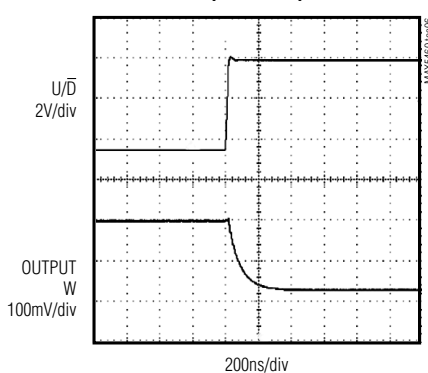

32-Tap FleaPoT™, 2-Wire Digital Potentiometers

Typical Operating Characteristics (continued)

(T_A = +25°C, unless otherwise noted.)

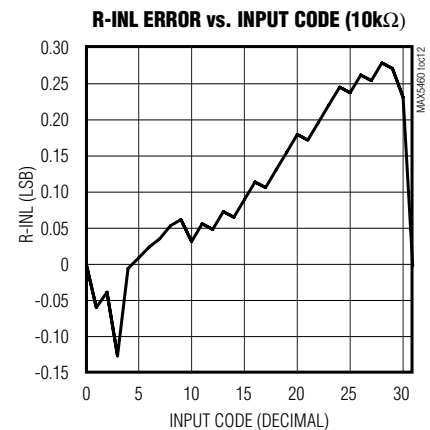
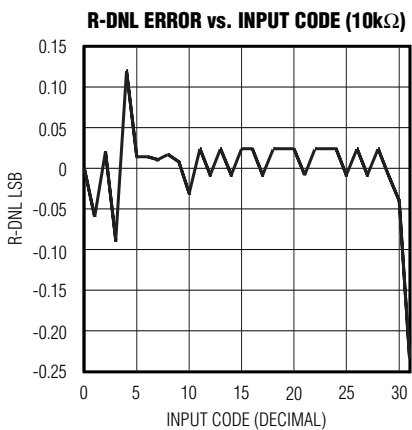
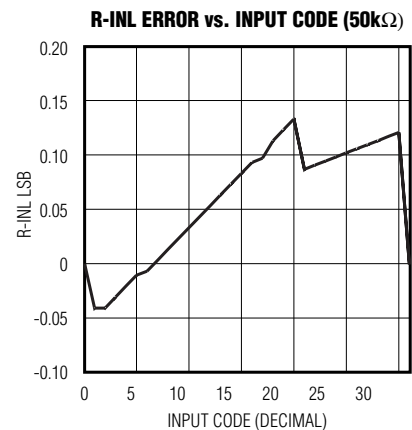
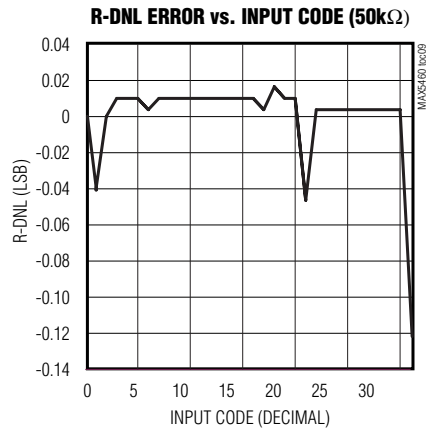
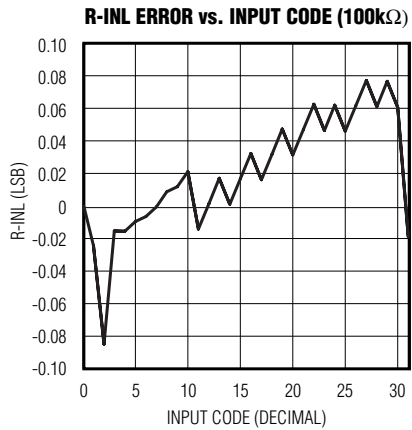
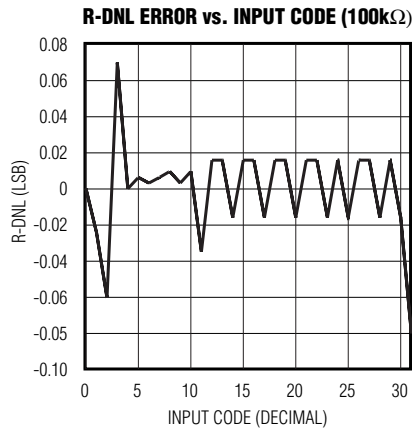

Pin Description

PIN			NAME	FUNCTION
MAX5460 MAX5463 MAX5466	MAX5467	MAX5468		
1	1	1	V _{DD}	Power Supply
2	2	2	GND	Ground
3	3	3	U/ \bar{D}	Up/Down Control Input. With \bar{CS} low, a low-to-high transition increments or decrements the wiper position.
4	4	4	\bar{CS}	Chip Select Input. A high-to-low \bar{CS} transition determines the mode: increment if U/ \bar{D} is high, or decrement if U/ \bar{D} is low.
5	6	6	H	High Terminal of Resistor
2	5	2	L	Low Terminal of Resistor
5	6	5	W	Wiper Terminal of Resistor

32-Tap FleaPoT™, 2-Wire Digital Potentiometers

Detailed Description

The MAX5460/MAX5463/MAX5466/MAX5467/MAX5468 consist of a fixed resistor and a wiper contact with 32 tap points that are digitally controlled through a 2-wire serial interface. Three resistance values are available: 10kΩ (MAX5466/MAX5467/MAX5468), 50kΩ (MAX5463), and 100kΩ (MAX5460).

The MAX5468 is designed to operate as a potentiometer. In this configuration, the low terminal of the resistor array is connected to ground (pin 2).

The MAX5467 performs as a variable resistor. In this device, the wiper terminal and high terminal of the resistor array are connected at pin 5. The MAX5460/MAX5463/MAX5466 are similar variable resistors, except the low terminal is connected to ground (pin 2).

Digital Interface Operation

The MAX5460/MAX5463/MAX5466/MAX5467/MAX5468 have two modes of operation when the serial interface is

active: increment and decrement mode. The serial interface is only active when \overline{CS} is low.

The \overline{CS} and U/\overline{D} inputs control the position of the wiper along the resistor array. When \overline{CS} transitions from high to low, the part will go into increment mode if U/\overline{D} is high, and into decrement mode if U/\overline{D} is low. Once the mode is set, the device will remain in that mode until \overline{CS} goes high again. A low-to-high transition at the U/\overline{D} pin will increment or decrement the wiper position depending on the current mode (Figures 1 and 2).

When the \overline{CS} input transitions to high (serial interface inactive), the value of the counter is stored and the wiper position is maintained.

Power-On Reset

All parts in this family feature power-on reset (POR) circuitry that sets the wiper position to midscale at power-up. By default, the chip is in the increment mode.

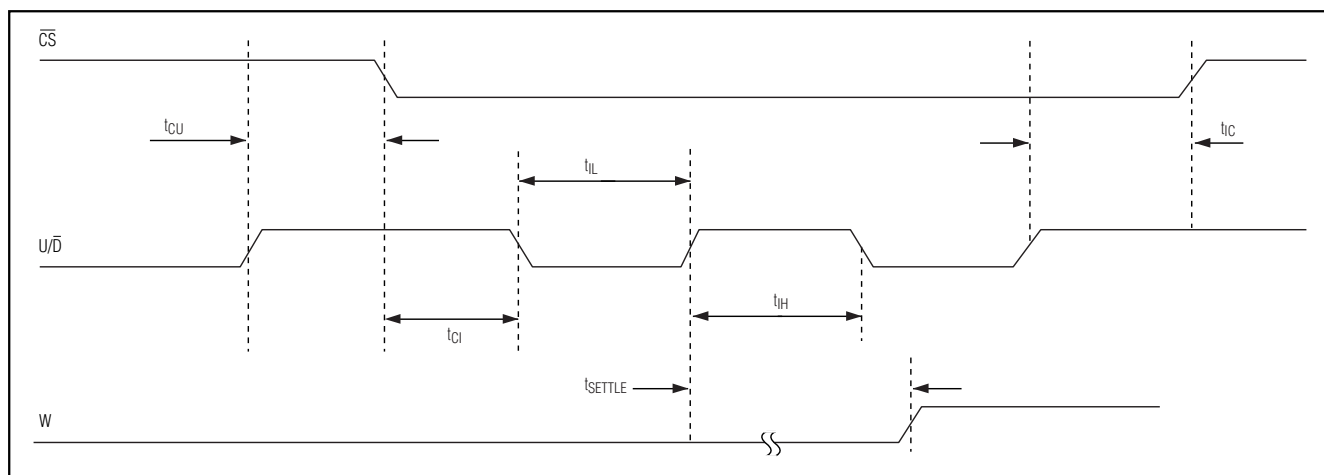

Figure 1. Serial Interface Timing Diagram, Increment Mode

MAX5460/MAX5463/MAX5466/MAX5467/MAX5468

32-Tap FleaPoT™, 2-Wire Digital Potentiometers

Applications Information

The MAX5460/MAX5463/MAX5466/MAX5467/MAX5468 are intended for circuits requiring digitally controlled adjustable resistance, such as LCD contrast control, where voltage biasing adjusts the display contrast.

Controlling a Switch-Mode LCD Bias Generator

Figure 3 shows an application where the variable resistor is used with a MAX1771 to make an adjustable positive LCD-bias circuit. The output of the MAX1771 is a positive voltage that is digitally controlled through the MAX5467. Similarly, Figure 4 shows the application of the variable resistor in a digitally controlled negative LCD-bias circuit along with the MAX774/MAX775/MAX776.

Alternative Positive LCD Bias Control

Alternatively, use an op amp to provide buffering and gain to the output of the MAX5468. Connect the mechanical potentiometer to the positive input of a non-inverting op amp (Figure 5) to select a portion of the input signal by digitally controlling the wiper terminal. Figure 6 shows a similar circuit for the MAX5467.

Adjustable Gain

Figure 7 shows how to use the variable resistor to digitally adjust the gain of a noninverting op amp configuration. Connect the MAX5467 in series with a resistor to ground to form the adjustable gain control of a noninverting amplifier. The MAX5460/MAX5463/MAX5466/MAX5467/MAX5468 have a low 5ppm/°C ratiometric tempco that allows for a very stable adjustable gain configuration over temperature.

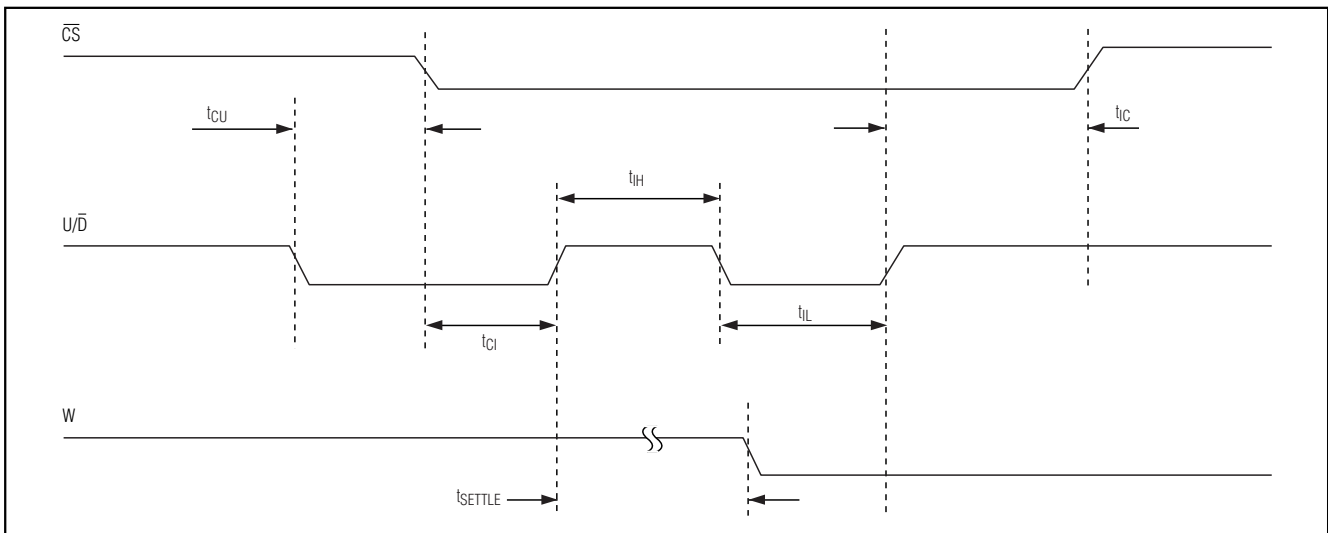

Figure 2. Serial Interface Timing Diagram, Decrement Mode

32-Tap FleaPoT™, 2-Wire Digital Potentiometers

MAX5460/MAX5463/MAX5466/MAX5467/MAX5468

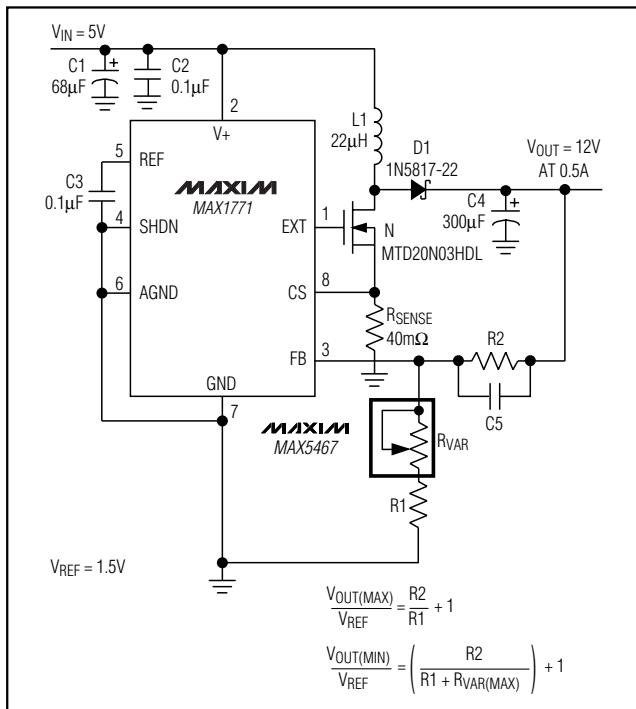

Figure 3. Adjustable Positive LCD Bias

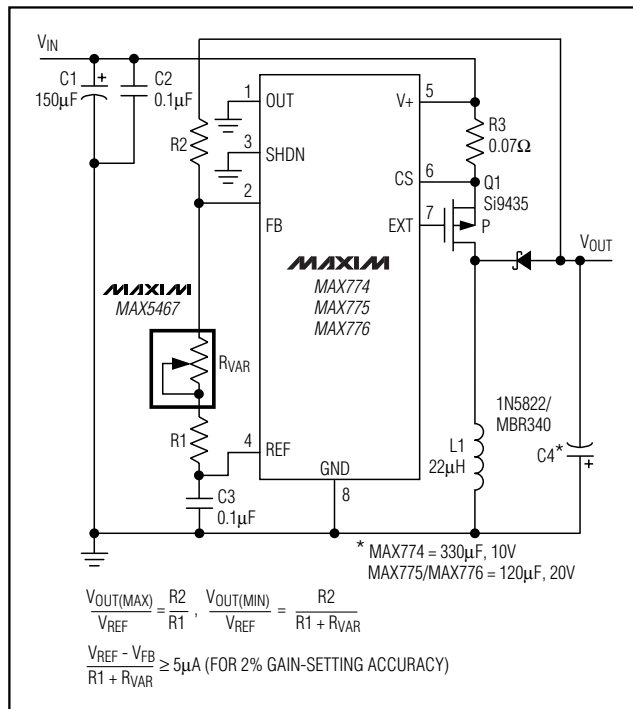

Figure 4. Adjustable Negative LCD Bias

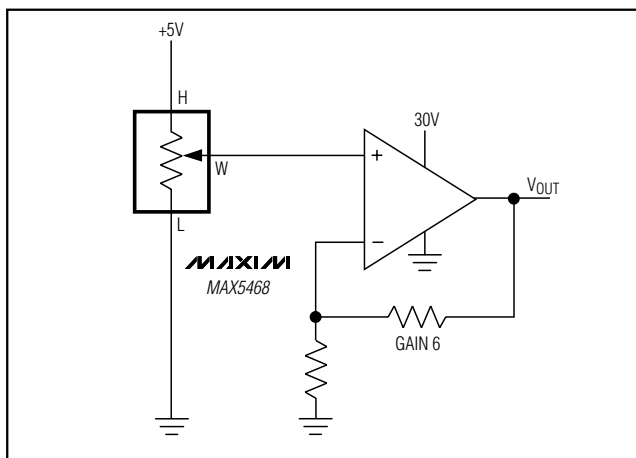

Figure 5. Positive LCD Bias Control

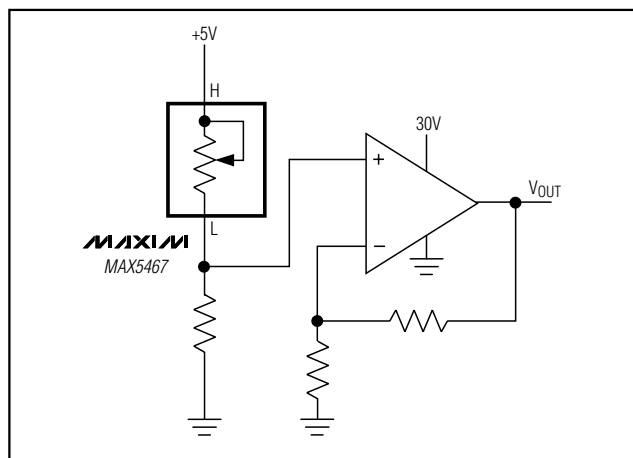

Figure 6. Positive LCD Bias Control

32-Tap FleaPoT™, 2-Wire Digital Potentiometers

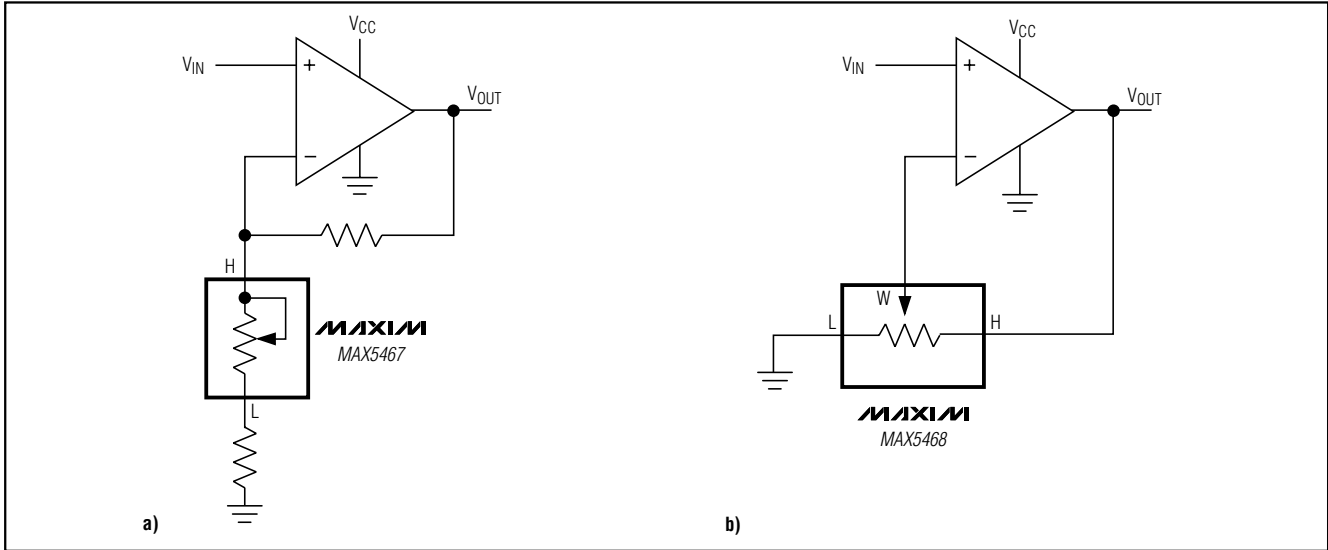
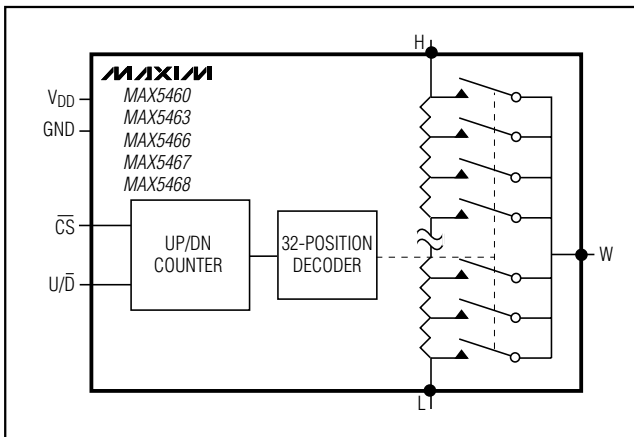

Figure 7. Adjustable Gain Circuit

Functional Diagram



Chip Information

TRANSISTOR COUNT: 792

32-Tap FleaPoT™, 2-Wire Digital Potentiometers

Package Information

MAX5460/MAX5463/MAX5466/MAX5467/MAX5468

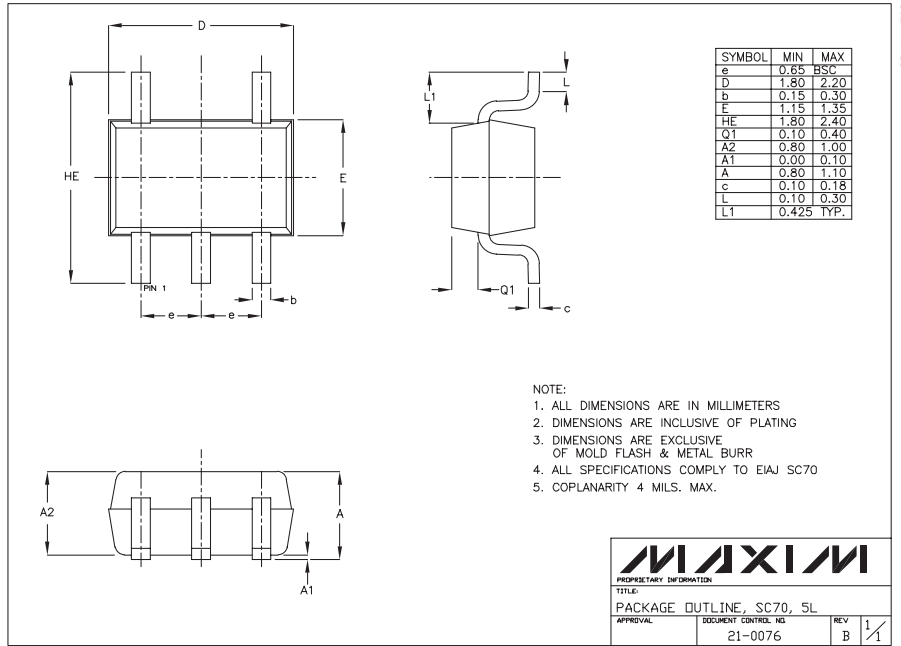

SC70-5LEFS

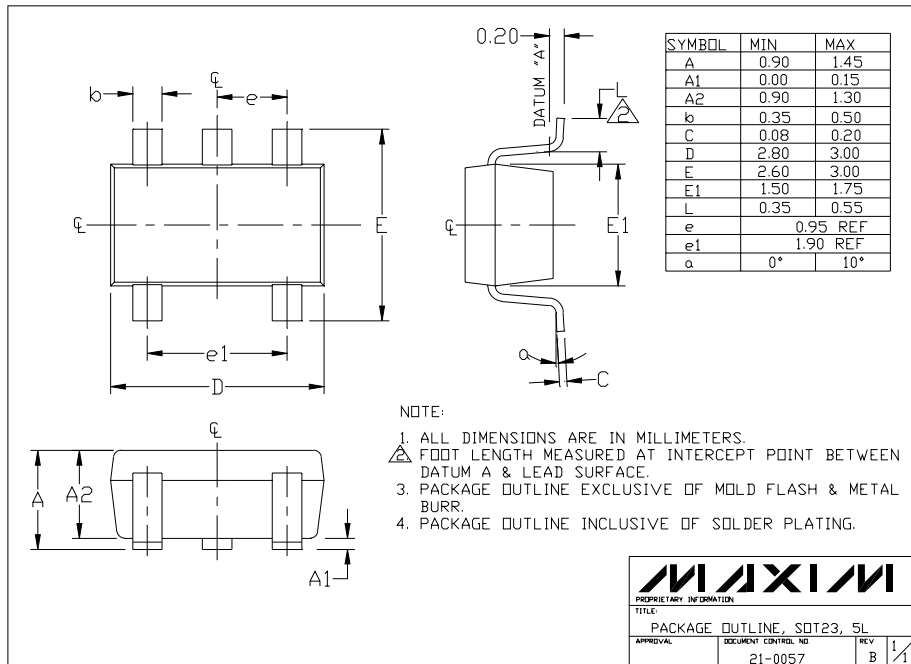

SOT23

32-Tap FleaPoT™, 2-Wire Digital Potentiometers

Package Information (continued)

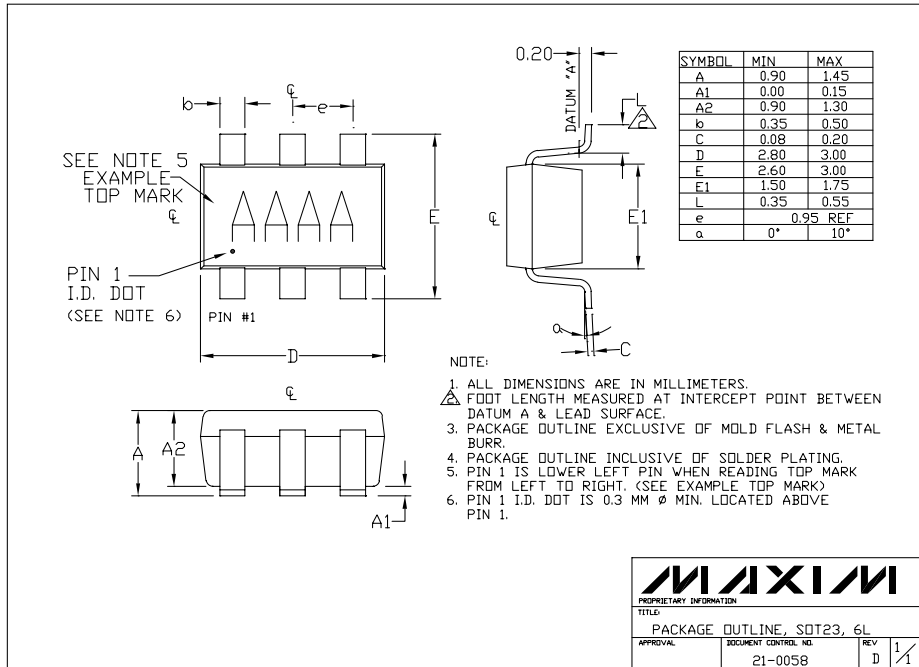

6LS0T.EPS

MAXIM
 PROPRIETARY INFORMATION
 TITLE: PACKAGE OUTLINE, SDT23, 6L
 APPROVAL: _____ DOCUMENT CONTROL NO: 21-0058 REV: D 1/1

Maxim cannot assume responsibility for use of any circuitry other than circuitry entirely embodied in a Maxim product. No circuit patent licenses are implied. Maxim reserves the right to change the circuitry and specifications without notice at any time.

10 _____ Maxim Integrated Products, 120 San Gabriel Drive, Sunnyvale, CA 94086 408-737-7600