

Glencoe Mathematics

Mastering the TAKS

(Texas Assessment of
Knowledge and Skills)

Grade 7

Diagnose Prescribe Practice Benchmark



Glencoe

New York, New York Columbus, Ohio Chicago, Illinois Peoria, Illinois Woodland Hills, California

Test-Taking Tips

- Go to bed early the night before the test. You will think more clearly after a good night's rest.
- Read each problem carefully, and think about ways to solve the problem before you try to answer the question.
- Relax. Most people get nervous when taking a test. It's natural. Just do your best.
- Answer questions that you are sure about first. If you do not know the answer to a question, skip it and go back to that question later.
- Think positively. Some problems may seem hard to you, but you may be able to figure out what to do if you read each question carefully.
- If no figure is provided, draw one. If one is furnished, mark it in any way that will help you solve the problem.
- When you have finished each problem, reread it to make sure that your answer is reasonable.
- Become familiar with a variety of formulas and when they should be used.
- Make sure that the number of the question on the answer sheet matches the number of the question on which you are working in your test booklet.



The McGraw-Hill Companies

Copyright © by The McGraw-Hill Companies, Inc. All rights reserved. Except as permitted under the United States Copyright Act, no part of this publication may be reproduced or distributed in any form or by any means, or stored in a database or retrieval system, without prior permission of the publisher.

Send all inquiries to:
Glencoe/McGraw-Hill
8787 Orion Place
Columbus, OH 43240-4027

ISBN 13: 978-0-07-876068-6
ISBN 10: 0-07-876068-2

Mastering the TAKS: Diagnose–Prescribe–Practice–Benchmark, Grade 7

Printed in the United States of America.

1 2 3 4 5 6 7 8 9 10 009 15 14 13 12 11 10 09 08 07 06

Road Map to TAKS Success

An Annotated Table of Contents

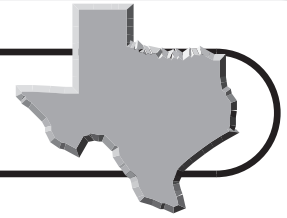

Steps to Success	Page(s)
------------------	---------

1 Diagnose Your Needs

Learn what mathematics skills are assessed on the TAKS.

Texas Essential Knowledge and Skills (TEKS), Grade 7 Mathematics	vi–ix
---	-------

Take the Diagnostic Test to find out which mathematics skills you have mastered.

Diagnostic Test.....	1–10
----------------------	------

Record your mastered skills.

Student Recording Chart.....	v
------------------------------	---

If you made a perfect score on your Diagnostic Test, proceed to Step 3 on the next page.

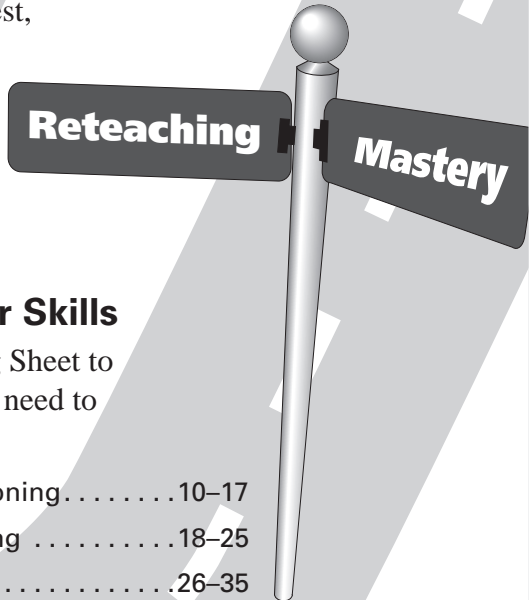

2 Prescribe Ways to Improve Your Skills

Use the information from your Student Recording Sheet to determine which Practice by Objective pages you need to complete to improve your mathematics skills.

Numbers, Operations, and Quantitative Reasoning.....	10–17
Patterns, Relationships, and Algebraic Thinking	18–25
Geometry and Spatial Reasoning	26–35
Measurement.....	36–38
Probability and Statistics	39–45
Underlying Processes and Mathematical Tools	46–53

continued on the next page

Road Map to TAKS Success

An Annotated Table of Contents

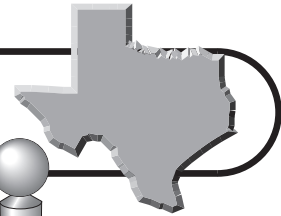

Practice

Mastery

Steps to Success

Page(s)

3

Practice Your Test Skills

Take the Practice Test to determine how you have improved your mathematics skills.

Practice Test54–62

Approximately 10 weeks before your test date, begin the Countdown to TAKS. This contains problems that are similar to those found on the TAKS.

Countdown to TAKS63–87

Work on the problems for each day unless your teacher instructs you to do otherwise. Each question tells which objective is being assessed.

4

Benchmark Your Progress

Monitor your progress as the year progresses by taking the Benchmark Tests. You can record your progress with each test.

Mastery of Objectives Chartx

Each Benchmark Test assesses the same concepts but is taken at a different time during the school year. Your test scores should improve with each test taken.

Benchmark Test 1 (take in late October) 88–97

Benchmark Test 2 (take in early January) 98–107

Benchmark Test 3 (take in early February)108–117

Welcome to
Success!

Student Recording Chart

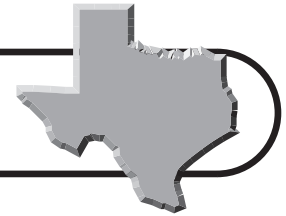

Directions Mark an \times next to each question from the Diagnostic Test that you answered *incorrectly*. If there is an \times marked for an Objective, write *Yes* in the *Need Practice?* box. Then complete the practice pages for that Objective.

Objective 1	7.1(A)	7.1(B)	7.1(C)	7.2(A)	7.2(B)
Test Questions	11 <input type="checkbox"/>	5 <input type="checkbox"/> 17 <input type="checkbox"/>	6 <input type="checkbox"/>	33 <input type="checkbox"/>	43 <input type="checkbox"/>
Need Practice?					
Practice Pages					

Objective 1	7.2(C)	7.2(D)	7.2(E)	7.2(F)	7.2(G)
Test Questions	42 <input type="checkbox"/>	48 <input type="checkbox"/>	10 <input type="checkbox"/>	32 <input type="checkbox"/>	18 <input type="checkbox"/>
Need Practice?					
Practice Pages					

Objective 2	7.3(A)	7.3(B)	7.4(A)	7.4(B)	7.4(C)	7.5(A)	7.5(B)
Test Questions	21 <input type="checkbox"/>	2 <input type="checkbox"/>	14 <input type="checkbox"/>	31 <input type="checkbox"/>	4 <input type="checkbox"/> 44 <input type="checkbox"/>	19 <input type="checkbox"/>	8 <input type="checkbox"/>
Need Practice?							
Practice Pages							

Objective 3	7.6(A)	7.6(B)	7.6(C)	7.6(D)
Test Questions	1 <input type="checkbox"/>	9 <input type="checkbox"/>	26 <input type="checkbox"/>	37 <input type="checkbox"/>
Need Practice?				
Practice Pages				

Objective 3	7.7(A)	7.7(B)	7.8(A)	7.8(B)	7.8(C)
Test Questions	35 <input type="checkbox"/>	20 <input type="checkbox"/>	16 <input type="checkbox"/>	22 <input type="checkbox"/>	41 <input type="checkbox"/>
Need Practice?					
Practice Pages					

Objective 4	7.9(A)
Test Questions	7 <input type="checkbox"/> 25 <input type="checkbox"/> 30 <input type="checkbox"/> 47 <input type="checkbox"/>
Need Practice?	
Practice Pages	

Objective 5	7.10(A)	7.11(A)	7.11(B)	7.12(A)	7.12(B)
Test Questions	23 <input type="checkbox"/> 36 <input type="checkbox"/>	29 <input type="checkbox"/>	12 <input type="checkbox"/>	3 <input type="checkbox"/> 45 <input type="checkbox"/>	27 <input type="checkbox"/>
Need Practice?					
Practice Pages					

Objective 6	7.13(A)	7.13(B)	7.13(C)	7.14(A)	7.15(A)	7.15(B)
Test Questions	13 <input type="checkbox"/> 46 <input type="checkbox"/>	34 <input type="checkbox"/>	28 <input type="checkbox"/> 40 <input type="checkbox"/>	15 <input type="checkbox"/> 38 <input type="checkbox"/>	24 <input type="checkbox"/>	39 <input type="checkbox"/>
Need Practice?						
Practice Pages						

Texas Assessment of Knowledge and Skills, Grade 7

TAKS Objectives and TEKS Student Expectations	
(7.1)	<p>Number, operation, and quantitative reasoning. The student represents and uses numbers in a variety of equivalent forms. The student is expected to:</p> <p>(A) compare and order integers and positive rational numbers;</p> <p>(B) convert between fractions, decimals, whole numbers, and percents mentally, on paper, or with a calculator; and</p> <p>(C) represent squares and square roots using geometric models.</p>
(7.2)	<p>Number, operation, and quantitative reasoning. The student adds, subtracts, multiplies, or divides to solve problems and justify solutions. The student is expected to:</p> <p>(A) represent multiplication and division situations involving fractions and decimals with models, including concrete objects, pictures, words, and numbers;</p> <p>(B) use addition, subtraction, multiplication, and division to solve problems involving fractions and decimals;</p> <p>(C) use models such as concrete objects, pictorial models, and number lines, to add, subtract, multiply, and divide integers and connect the actions to algorithms;</p> <p>(D) use division to find unit rates and ratios in proportional relationships such as speed, density, price, recipes, and student-teacher ratio;</p> <p>(E) simplify numerical expressions involving order of operations and exponents;</p> <p>(F) select and use appropriate operations to solve problems and justify the selections; and</p> <p>(G) determine the reasonableness of a solution to a problem.</p>
(7.3)	<p>Patterns, relationships, and algebraic thinking. The student solves problems involving direct proportional relationships. The student is expected to:</p> <p>(A) estimate and find solutions to application problems involving percent; and</p> <p>(B) estimate and find solutions to application problems involving proportional relationships such as similarity, scaling, unit costs, and related measurement units.</p>
(7.4)	<p>Patterns, relationships, and algebraic thinking. The student represents a relationship in numerical, geometric, verbal, and symbolic form. The student is expected to:</p> <p>(A) generate formulas involving unit conversions, perimeter, area, circumference, volume, and scaling;</p> <p>(B) graph data to demonstrate relationships in familiar concepts such as conversions, perimeter, area, circumference, volume, and scaling; and</p> <p>(C) use words and symbols to describe the relationship between the terms in an arithmetic sequence (with a constant rate of change) and their positions in the sequence.</p>
(7.5)	<p>Patterns, relationships, and algebraic thinking. The student uses equations to solve problems. The student is expected to:</p> <p>(A) use concrete and pictorial models to solve equations and use symbols to record the actions; and</p> <p>(B) formulate problem situations when given a simple equation and formulate an equation when given a problem situation.</p>

TAKS Objectives and TEKS Student Expectations

(7.6)	<p>Geometry and spatial reasoning. The student compares and classifies two- and three-dimensional figure using geometric vocabulary and properties. The student is expected to:</p> <p>(A) use angle measurements to classify pairs of angles as complementary or supplementary;</p> <p>(B) use properties to classify triangles and quadrilaterals;</p> <p>(C) use properties to classify three-dimensional figures, including pyramids, cones, prisms, and cylinders; and</p> <p>(D) use critical attributes to define similarity.</p>
(7.7)	<p>Geometry and spatial reasoning. The student uses coordinate geometry to describe location on a plane. The student is expected to:</p> <p>(A) locate and name points on a coordinate plane using ordered pairs of integers; and</p> <p>(B) graph reflections across the horizontal or vertical axis and graph translations on a coordinate plane.</p>
(7.8)	<p>Geometry and spatial reasoning. The student uses geometry to model and describe the physical world. The student is expected to:</p> <p>(A) sketch three-dimensional figures when given the top, side, and front views;</p> <p>(B) make a net (two-dimensional model) of the surface area of a three-dimensional figure; and</p> <p>(C) use geometric concepts and properties to solve problems in fields such as art and architecture.</p>
(7.9)	<p>Measurement. The student solves application problems involving estimation and measurement. The student is expected to:</p> <p>(A) estimate measurements and solve application problems involving length (including perimeter and circumference) and area of polygons and other shapes;</p> <p>(B) connect models for volume of prisms (triangular and rectangular) and cylinders to formulas of prisms (triangular and rectangular) and cylinders; and</p> <p>(C) estimate measurements and solve application problems involving volume of prisms (rectangular and triangular) and cylinders.</p>

TAKS Objectives and TEKS Student Expectations

(7.10)	Probability and Statistics. The student recognizes that a physical or mathematical model can be used to describe the experimental and theoretical probability of real-life events. The student is expected to: (A) construct sample spaces for simple or composite experiments; and (B) find the probability of independent events.
(7.11)	Probability and Statistics. The student understands that the way a set of data is displayed influences its interpretation. The student is expected to: (A) select and use an appropriate representation for presenting and displaying relationships among collected data, including line plot, line graph, bar graph, stem and leaf plot, circle graph, and Venn diagrams, and justify the selection; and (B) make inferences and convincing arguments based on an analysis of given or collected data.
(7.12)	Probability and Statistics. The student uses measures of central tendency and range to describe a set of data. The student is expected to: (A) describe a set of data using mean, median, mode, and range; and (B) choose among mean, median, mode, or range to describe a set of data and justify the choice for a particular situation.

TAKS Objectives and TEKS Student Expectations

(7.13)	<p>Underlying processes and mathematical tools. The student applies Grade 7 mathematics to solve problems connected to everyday experiences, investigations in other disciplines, and activities in and outside of school. The student is expected to:</p> <ul style="list-style-type: none"> (A) identify and apply mathematics to everyday experiences, to activities in and outside of school, with other disciplines, and with other mathematical topics; (B) use a problem-solving model that incorporates understanding the problem, making a plan, carrying out the plan, and evaluating the solution for reasonableness; (C) select or develop an appropriate problem-solving strategy from a variety of different types, including drawing a picture, looking for a pattern, systematic guessing and checking, acting it out, making a table, working a simpler problem, or working backwards to solve a problem; and (D) select tools such as real objects, manipulatives, paper/pencil, and technology or techniques such as mental math, estimation, and number sense to solve problems.
(7.14)	<p>Underlying processes and mathematical tools. The student communicates about Grade 7 mathematics through informal and mathematical language, representations, and models. The student is expected to:</p> <ul style="list-style-type: none"> (B) evaluate the effectiveness of different representations to communicate ideas. (A) communicate mathematical ideas using language, efficient tools, appropriate units, and graphical, numerical, physical, or algebraic mathematical models.
(7.15)	<p>Underlying processes and mathematical tools. The student uses logical reasoning to make conjectures and verify conclusions. The student is expected to:</p> <ul style="list-style-type: none"> (A) make conjectures from patterns or sets of examples and nonexamples; and (B) validate his/her conclusions using mathematical properties and relationships.

Mastery of Objectives Chart

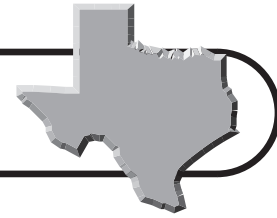

Directions Mark a ✓ by each question from the Benchmark Test that you answer *correctly*. The goal is to gain more ✓s with each Benchmark Test you take.

	Test 1	Test 2	Test 3
Objective	Date:	Date:	Date:
<i>Numbers, Operations, and Quantitative Reasoning</i>	Questions: <input type="checkbox"/> 1 <input type="checkbox"/> 19 <input type="checkbox"/> 5 <input type="checkbox"/> 23 <input type="checkbox"/> 7 <input type="checkbox"/> 29 <input type="checkbox"/> 11 <input type="checkbox"/> 32 <input type="checkbox"/> 14 <input type="checkbox"/> 37	Questions: <input type="checkbox"/> 1 <input type="checkbox"/> 19 <input type="checkbox"/> 5 <input type="checkbox"/> 23 <input type="checkbox"/> 7 <input type="checkbox"/> 29 <input type="checkbox"/> 11 <input type="checkbox"/> 32 <input type="checkbox"/> 14 <input type="checkbox"/> 37	Questions: <input type="checkbox"/> 1 <input type="checkbox"/> 19 <input type="checkbox"/> 5 <input type="checkbox"/> 23 <input type="checkbox"/> 7 <input type="checkbox"/> 29 <input type="checkbox"/> 11 <input type="checkbox"/> 32 <input type="checkbox"/> 14 <input type="checkbox"/> 37
<i>Patterns, Relationships, and Algebraic Thinking</i>	Questions: <input type="checkbox"/> 2 <input type="checkbox"/> 26 <input type="checkbox"/> 15 <input type="checkbox"/> 40 <input type="checkbox"/> 16 <input type="checkbox"/> 44 <input type="checkbox"/> 20 <input type="checkbox"/> 46	Questions: <input type="checkbox"/> 2 <input type="checkbox"/> 26 <input type="checkbox"/> 15 <input type="checkbox"/> 40 <input type="checkbox"/> 16 <input type="checkbox"/> 44 <input type="checkbox"/> 20 <input type="checkbox"/> 46	Questions: <input type="checkbox"/> 2 <input type="checkbox"/> 26 <input type="checkbox"/> 15 <input type="checkbox"/> 40 <input type="checkbox"/> 16 <input type="checkbox"/> 44 <input type="checkbox"/> 20 <input type="checkbox"/> 46
<i>Geometry and Spatial Reasoning</i>	Questions: <input type="checkbox"/> 3 <input type="checkbox"/> 12 <input type="checkbox"/> 4 <input type="checkbox"/> 25 <input type="checkbox"/> 6 <input type="checkbox"/> 30	Questions: <input type="checkbox"/> 3 <input type="checkbox"/> 12 <input type="checkbox"/> 4 <input type="checkbox"/> 25 <input type="checkbox"/> 6 <input type="checkbox"/> 30	Questions: <input type="checkbox"/> 3 <input type="checkbox"/> 12 <input type="checkbox"/> 4 <input type="checkbox"/> 25 <input type="checkbox"/> 6 <input type="checkbox"/> 30
<i>Measurement</i>	Questions: <input type="checkbox"/> 10 <input type="checkbox"/> 28 <input type="checkbox"/> 13 <input type="checkbox"/> 33 <input type="checkbox"/> 24 <input type="checkbox"/> 41	Questions: <input type="checkbox"/> 10 <input type="checkbox"/> 28 <input type="checkbox"/> 13 <input type="checkbox"/> 33 <input type="checkbox"/> 24 <input type="checkbox"/> 41	Questions: <input type="checkbox"/> 10 <input type="checkbox"/> 28 <input type="checkbox"/> 13 <input type="checkbox"/> 33 <input type="checkbox"/> 24 <input type="checkbox"/> 41
<i>Probability and Statistics</i>	Questions: <input type="checkbox"/> 17 <input type="checkbox"/> 35 <input type="checkbox"/> 21 <input type="checkbox"/> 36 <input type="checkbox"/> 22 <input type="checkbox"/> 43 <input type="checkbox"/> 34	Questions: <input type="checkbox"/> 17 <input type="checkbox"/> 35 <input type="checkbox"/> 21 <input type="checkbox"/> 36 <input type="checkbox"/> 22 <input type="checkbox"/> 43 <input type="checkbox"/> 34	Questions: <input type="checkbox"/> 17 <input type="checkbox"/> 35 <input type="checkbox"/> 21 <input type="checkbox"/> 36 <input type="checkbox"/> 22 <input type="checkbox"/> 43 <input type="checkbox"/> 34
<i>Underlying Processes and Mathematical Tools</i>	Questions: <input type="checkbox"/> 8 <input type="checkbox"/> 38 <input type="checkbox"/> 9 <input type="checkbox"/> 39 <input type="checkbox"/> 18 <input type="checkbox"/> 42 <input type="checkbox"/> 27 <input type="checkbox"/> 45 <input type="checkbox"/> 31	Questions: <input type="checkbox"/> 8 <input type="checkbox"/> 38 <input type="checkbox"/> 9 <input type="checkbox"/> 39 <input type="checkbox"/> 18 <input type="checkbox"/> 42 <input type="checkbox"/> 27 <input type="checkbox"/> 45 <input type="checkbox"/> 31	Questions: <input type="checkbox"/> 8 <input type="checkbox"/> 38 <input type="checkbox"/> 9 <input type="checkbox"/> 39 <input type="checkbox"/> 18 <input type="checkbox"/> 42 <input type="checkbox"/> 27 <input type="checkbox"/> 45 <input type="checkbox"/> 31

Mathematics Chart

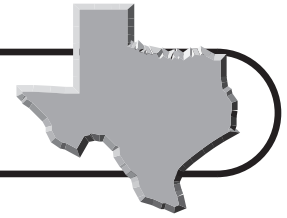

Perimeter

rectangle $P = 2\ell + 2w$ or
 $P = 2(\ell + w)$

Circumference

circle $C = 2\pi r$ or $C = \pi d$

Area

rectangle $A = \ell w$ or $A = bh$

triangle $A = \frac{1}{2}bh$ or $A = \frac{bh}{2}$

trapezoid $A = \frac{1}{2}(b_1 + b_2)h$ or
 $A = \frac{(b_1 + b_2)h}{2}$

circle $A = \pi r^2$

Surface Area

cube $S = 6s^2$

cylinder (lateral) $S = 2\pi rh$

cylinder (total) $S = 2\pi rh + 2\pi r^2$ or
 $S = 2\pi r(h + r)$

cone (lateral) $S = \pi r\ell$

cone (total) $S = \pi r\ell + \pi r^2$ or
 $S = \pi r(\ell + r)$

sphere $S = 4\pi r^2$

Volume

prism or cylinder $V = Bh^*$

pyramid or cone $V = \frac{1}{3}Bh^*$

sphere $V = \frac{4}{3}\pi r^3$

* B represents the area of the base of a solid figure.

Pi

$$\pi \approx 3.14 \text{ or } \pi \approx \frac{22}{7}$$

Pythagorean Theorem

$$a^2 + b^2 = c^2$$

Slope of a Line

$$m = \frac{y_2 - y_1}{x_2 - x_1}$$

Standard Form of an Equation

$$Ax + By = C$$

Slope-Intercept Form of an Equation

$$y = mx + b$$

Point-Slope Form of an Equation

$$y - y_1 = m(x - x_1)$$

Distance Formula

$$d = \sqrt{(x_2 - x_1)^2 + (y_2 - y_1)^2}$$

Midpoint Formula

$$M = \left(\frac{x_1 + x_2}{2}, \frac{y_1 + y_2}{2} \right)$$

Quadratic Formula

$$x = \frac{-b \pm \sqrt{b^2 - 4ac}}{2a}$$

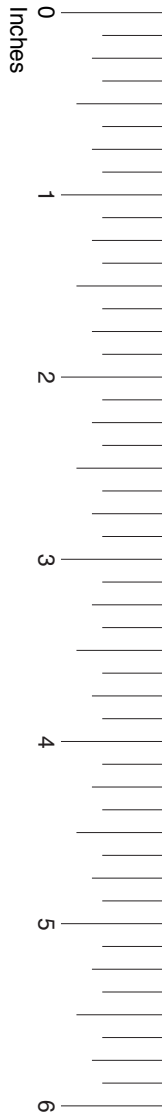

Mathematics Chart

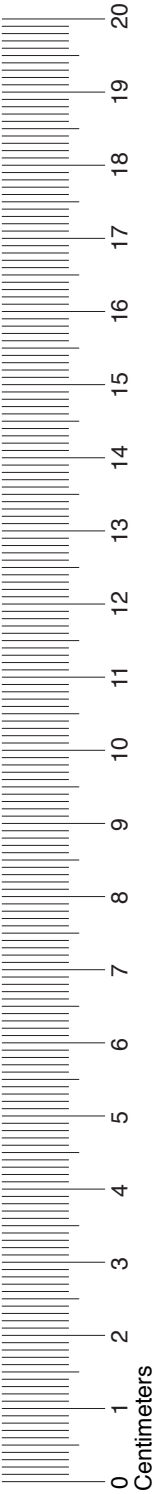
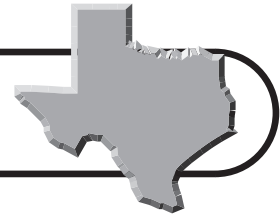

<p>LENGTH</p> <p>Metric</p> <p>1 kilometer = 1000 meters</p> <p>1 meter = 100 centimeters</p> <p>1 centimeter = 10 millimeters</p> <p>Customary</p> <p>1 mile = 1760 yards</p> <p>1 mile = 5280 feet</p> <p>1 yard = 3 feet</p> <p>1 foot = 12 inches</p>	<p>CAPACITY AND VOLUME</p> <p>Metric</p> <p>1 liter = 1000 milliliters</p> <p>Customary</p> <p>1 gallon = 4 quarts</p> <p>1 gallon = 128 ounces</p> <p>1 quart = 2 pints</p> <p>1 pint = 2 cups</p> <p>1 cup = 8 ounces</p>
<p>MASS AND WEIGHT</p> <p>Metric</p> <p>1 kilogram = 1000 grams</p> <p>1 gram = 1000 milligrams</p> <p>Customary</p> <p>1 ton = 2000 pounds</p> <p>1 pound = 16 ounces</p>	<p>TIME</p> <p>1 year = 365 days</p> <p>1 year = 12 months</p> <p>1 year = 52 weeks</p> <p>1 week = 7 days</p> <p>1 day = 24 hours</p> <p>1 hour = 60 minutes</p> <p>1 minute = 60 seconds</p>

Diagnostic Test

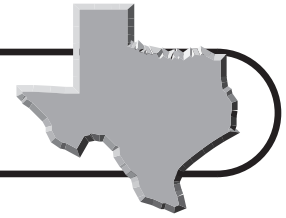

Read each question and choose the correct answer.

- 1** Which two angles in the parallelogram are supplementary? **(7.6)(A)**

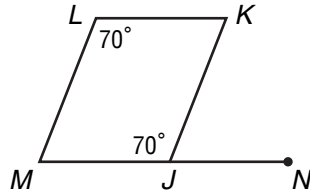

- A** $\angle MJK$ and $\angle JKL$
B $\angle MLK$ and $\angle MJK$
C $\angle LMJ$ and $\angle LKJ$
D $\angle LMJ$ and $\angle NJK$
- 2** One hundred people were surveyed to find out how much television they watch. Three out of every five people said they watch television for at least one hour each day. According to the survey, how many people watch television for at least one hour each day? **(7.3)(B)**
- F** 25
G 35
H 50
J 60
- 3** Ten students received the following scores on a math exam.
 85, 83, 91, 76, 82, 88, 96, 92, 78, 74
 What was the mean test score? **(7.12)(A)**
- A** 83.5
B 84
C 84.5
D 85

- 4** Which expression can be used to find the n th term in the sequence? **(7.4)(C)**

Position	1	2	3	4	5	n
Value of Term	5	7	9	11	13	

- F** $2n + 3$
G $n^2 + 2$
H $2n^2$
J $n + 3$
- 5** Which group does not contain equivalent fractions, decimals, and percents? **(7.1)(B)**
- A** $\frac{1}{4}$, 0.25, 25%
B $\frac{3}{5}$, 0.6, 60%
C $\frac{1}{20}$, 0.02, 2%
D $\frac{3}{10}$, 0.3, 30%
- 6** Which of the following does the model represent? **(7.1)(C)**

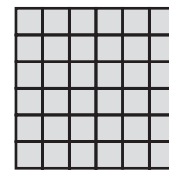

- F** $6^2 = 36$
G $6^2 = 12$
H $6^6 = 36$
J $6^2 = 8$



Diagnostic Test (continued)

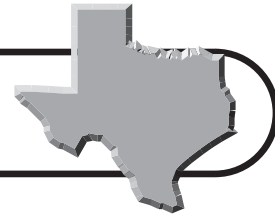

- 7** Theo bought a new aquarium that is 50 centimeters long, 28 centimeters wide, and 30 centimeters tall. He needs to find a space on his bookshelf for the aquarium. How much space does Theo need for his aquarium? **(7.9)(A)**

A 150 cm²
B 1500 cm²
C 75,000 cm²
D 125,000 cm²

- 8** Which problem situation matches the equation below? **(7.5)(B)**

$$x = 15 - 2(7.75)$$

F Paxton purchased two shirts that cost \$15.00 each. What is x , the amount of change he received from \$7.75?
G Terry bought movie tickets for \$7.75 each. What is x , the number of tickets that can be purchased for exactly \$15.00?
H Corinne bought two books for \$7.75 each, including tax. She gave the clerk \$15.00. What is x , the amount of change Corinne received?
J Gretchen measured how long it took to ride her bike from home to school, a distance of 7.75 miles. What is x , the amount of time it will take for her to ride her bike 15 miles?

- 9** Simplify the expression below. **(7.2)(E)**

$$4^2 + 3(9 - 5) \div 2$$

A 12
B 16
C 18
D 22

- 10** Roland made a sketch of a birdhouse he wants to build. Which of the following best describes the triangle with its given measures? **(7.6)(B)**

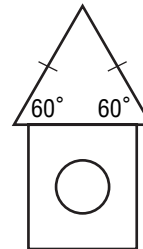

F Equilateral triangle
G Acute isosceles triangle
H Right scalene triangle
J Right isosceles triangle

- 11** A house has 4 different types of windows with each window frame having a different width. Which list shows the widths of the window frames in order from widest to most narrow? **(7.1)(A)**

A $2\frac{1}{2}$ in., $3\frac{1}{8}$ in., $\frac{3}{4}$ in., $1\frac{1}{4}$ in.
B $3\frac{1}{8}$ in., $2\frac{1}{2}$ in., $1\frac{1}{4}$ in., $\frac{3}{4}$ in.
C $2\frac{1}{2}$ in., $1\frac{1}{4}$ in., $\frac{3}{4}$ in., $3\frac{1}{8}$ in.
D $1\frac{1}{4}$ in., $3\frac{1}{8}$ in., $\frac{3}{4}$ in., $2\frac{1}{2}$ in.

- 12** Jennifer made a pizza crust with a diameter of 14 inches. Which expression could be used to find the area of the pizza crust? **(7.4)(A)**

F $\pi 14^2$ **H** $\pi 7^2$
G $14 - \pi^2$ **J** $\frac{7}{\pi}$



Diagnostic Test (continued)

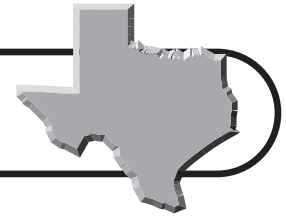

- 13** The table below shows the number of tickets sold on each day during the week for the school play.

Day of Week	Number of Tickets Sold
Monday	56
Tuesday	22
Wednesday	36
Thursday	78
Friday	112

Which statement is best supported by these data? **(7.11)(B)**

- A** The average number of tickets sold was 55.
- B** Almost twice as many tickets were sold on Friday as on Thursday.
- C** The number of tickets sold each day increased at the end of the week.
- D** Three times as many tickets were sold on Wednesday as on Tuesday.
- 14** Emily bought a leash for \$15.49, food bowls for \$7.99 each, a bag of puppy food for \$25.69, and a chew toy for \$3.79. She gave the cashier \$65.00. What information is needed to find the amount of change Emily received? **(7.13)(A)**
- F** How much her puppy eats
- G** How much food was in the bag
- H** How many food bowls she bought
- J** How many chew toys her puppy needs

- 15** The model represents the equation $2x - 10 = 4$. What is the value of x if $\ominus = -1$ and $\oplus = 1$? **(7.5)(A)**

$$\otimes \otimes \begin{matrix} \ominus & \ominus & \ominus & \ominus \\ \ominus & \ominus & \ominus & \ominus \end{matrix} = \oplus \oplus \oplus \oplus$$

- A** -3 **C** 1
- B** -1 **D** 7

- 16** In 2003, 1 out of every 20 Texans worked in the travel industry. Which equation can be used to find x , the percent of Texans who worked in the travel industry in 2003? **(7.14)(A)**

F $\frac{x}{100} = \frac{20}{1}$

G $\frac{x}{100} = \frac{1}{20}$

H $x = \frac{20}{100}$

J $100 = \frac{20}{x}$

- 17** The top, side, and front views of a solid figure made of cubes are shown below. **(7.8)(A)**

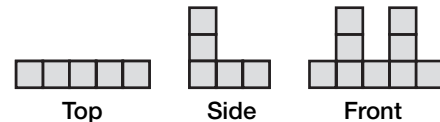

Which solid figure matches the views above?

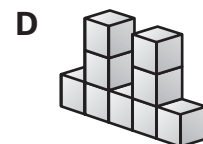
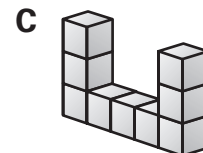
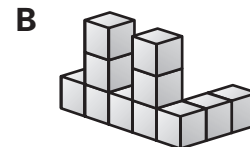
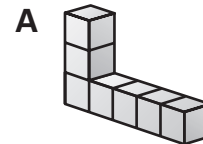

Diagnostic Test (continued)

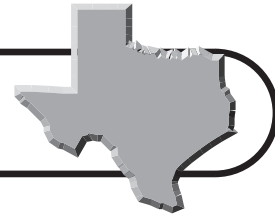

- 18** Eve made a checkerboard. She left half of the squares white and colored the other half. Of the squares she colored, she colored $\frac{1}{4}$ of them dark blue. What percent of the squares did she color dark blue? **(7.1)(B)**

F 12.5%
G 15%
H 18.5%
J 25%

- 19** Tickets to Six Flags Over Texas cost between \$35 and \$45 per person. Which is the best estimate of the total cost for a family of 6? **(7.2)(G)**

A From \$100 to \$150
B From \$150 to \$200
C From \$200 to \$250
D From \$250 to \$300

- 20** A toy company developed 32 new toys last year. Four of the toys were given awards for being educational. What percent of the new toys were not given awards for being educational? **(7.3)(A)**

F 12.5%
G 25.5%
H 75.5%
J 87.5%

- 21** Erin bought an 8-roll package of paper towels for \$9.76, tax included. How much did the towels cost per roll? **(7.2)(D)**

A \$1.22
B \$1.80
C \$17.76
D \$78.24

- 22** Triangle ABC was transformed to form Triangle $A'B'C'$ below. **(7.7)(B)**

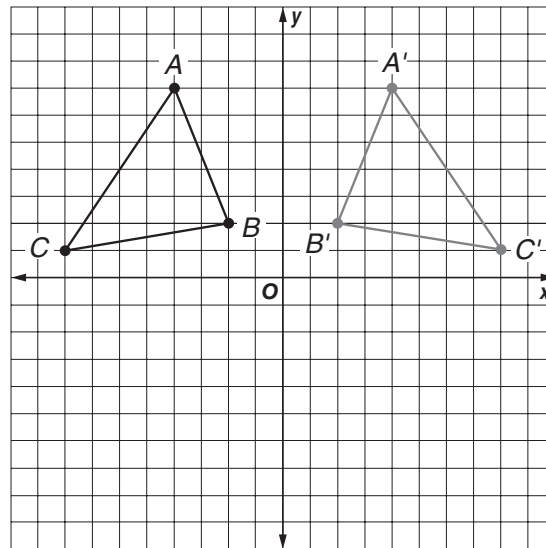

Which transformation is shown above?

F rotation
G reflection
H translation
J tessellation

- 23** In a clothes bag there are 3 green socks (G), 2 blue socks (B), and 1 red sock (R). One sock is taken out of the bag at random and not replaced. Then a second sock is taken out. Which choice shows all of the possible outcomes? **(7.10)(A)**

A GB, GR, GG, BG, BB, BR, RG, RB
B GB, GR, GG, BG, BB, BR, RG, RB, RR
C GB, GR, BG, BB, BR, RG, RB, RR
D GB, GR, GG, BG, BB, BR



Diagnostic Test (continued)

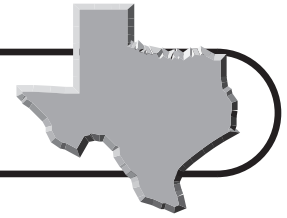

- 24** Tracy wants to make a paper ice cream cone for a school play prop. Which net can be used to make a cone? **(7.8)(B)**

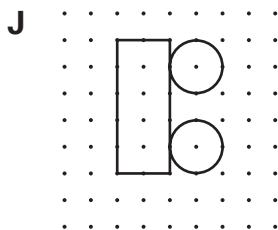
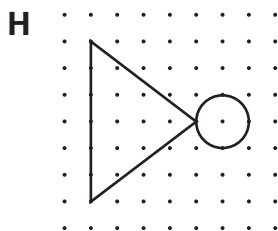
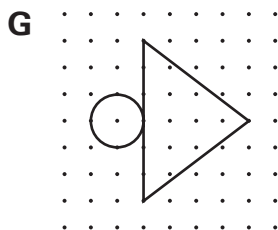
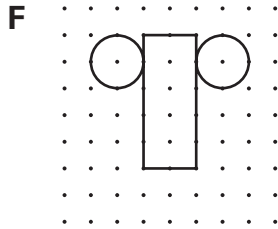

- 25** Which of the following has a base that is a polygon and has triangular sides that meet at a point? **(7.6)(C)**

- A** Cone
- B** Prism
- C** Cylinder
- D** Pyramid

- 26** Coach Jamison sorted Peter's swimming times in the 50-yard freestyle according to a certain rule. The times that follow the rule are listed in Set A. The times that do not follow the rule are in Set B. **(7.15)(A)**

Set A	52.91, 52.85, 53.02, 53.11, 52.64, 52.51
Set B	52.49, 52.35, 52.39, 52.42, 52.48

Based on this information, which statement is true?

- F** All of the numbers in Set A are greater than 52.5.
 - G** All of the numbers in Set A have exactly one 5.
 - H** All of the numbers in Set A include the digit 2.
 - J** All of the numbers in Set A are less than 53.0.
- 27** Scott is planning a new flower bed in his grandmother's yard. The bed is 3 feet wide and 5 feet long. How many feet of fencing will Scott need to buy to go around the new flower bed? **(7.9)(A)**
- A** 8
 - B** 15
 - C** 16
 - D** 30

- 28** Cory used $\frac{2}{3}$ of his money to buy a used bicycle. He then bought a new helmet for \$45.00 and had \$15.85 left over. How much did the bicycle cost? **(7.13)(C)**

- F** \$365.10
- G** \$182.55
- H** \$121.70
- J** \$60.85



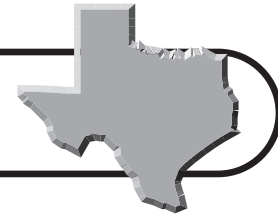

Diagnostic Test (continued)

29 Ms. Collins asked 15 students how many times they ate dinner with their families in one week. The responses are shown in the table.

Number of Times Ate Dinner with Family	Number of Students
1	0
2	2
3	1
4	4
5	3
6	5
7	0

Which measure of central tendency is best used to demonstrate that most students eat dinner with their families about 5 times a week? **(7.12)(B)**

- A** Mean
- B** Median
- C** Mode
- D** Range

30 The table below shows the number of points Sienna scored in each of the first 7 basketball games of the season.

Game	Points
1	4
2	10
3	10
4	6
5	12
6	18
7	13
8	

How many points must Sienna score in the 8th game for the mean and the mode of the set to be equal? **(7.12)(A)**

- F** 12 **H** 9
- G** 10 **J** 7

31 The table below shows which instruments students at Clearwater Middle School play. **(7.11)(A)**

Type of Instrument	Number of Students
Brass	38
Percussion	18
Wind	32
Strings	12

Which graph best shows the number of students who play each instrument compared to all students in the band?

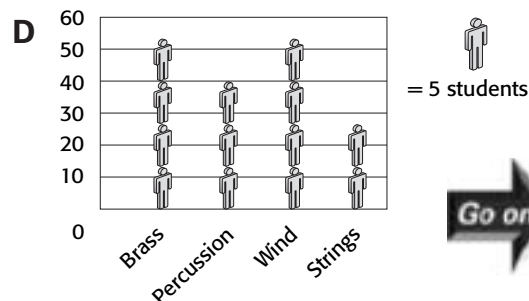
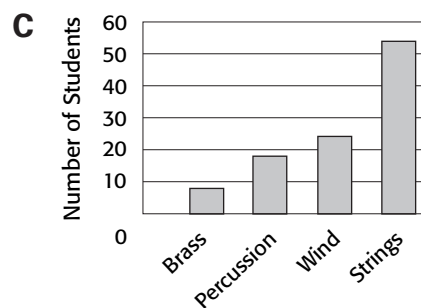
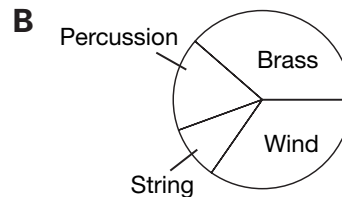
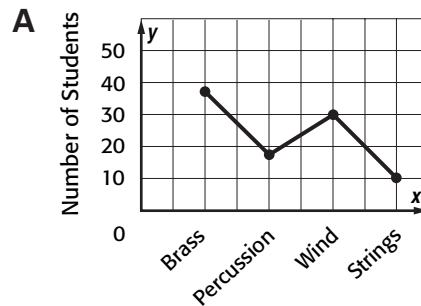

Diagnostic Test (continued)

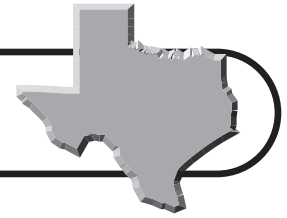

- 32** Shea made a small wooden picture frame in shop class. Use the ruler on the Mathematics Chart to measure the length and width of the picture frame. **(7.9)(A)**

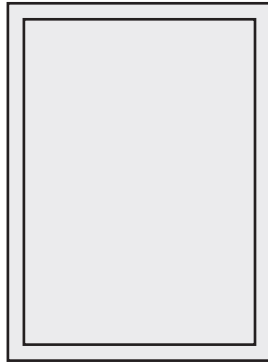

Which of the following is closest to the total length of wood Shea needed to make the four sides of the picture frame?

- F** 7 in. **H** 9 in.
G 8 in. **J** 10 in.
- 33** Jake bought 5 new CDs that were on sale for a cost of 3 CDs for \$33.33. He also bought a set of headphones for \$8.79. What is the total amount he spent? **(7.2)(F)**
- A** \$24.20
B \$41.78
C \$55.55
D \$64.34
- 34** Which graph below shows the relationship between quarts and gallons? **(7.4)(B)**

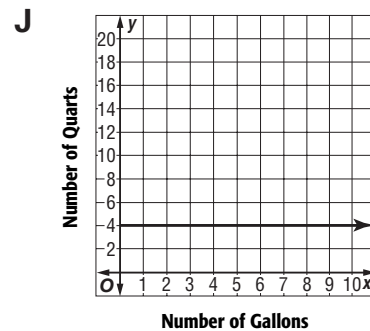
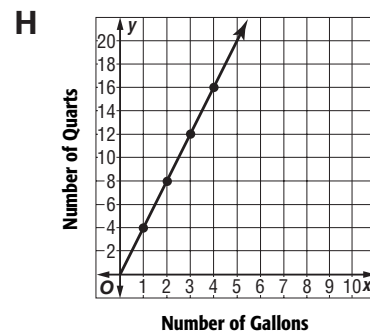
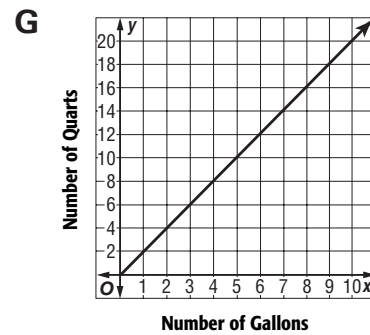
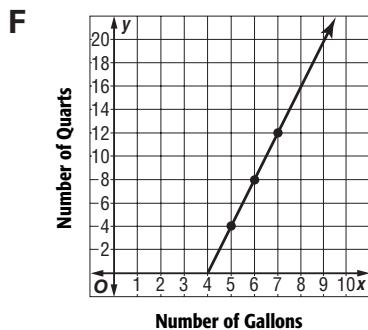

- 35** There are 79,535 miles of highway in Texas. There are also 101 rest areas along the highway. Which expression can be used to find the average number of miles of highway per rest area? **(7.2)(A)**
- A** $79,535 \div 101$
B $79,535 + 101$
C $79,535 - 101$
D $79,535 \times 101$



Diagnostic Test (continued)

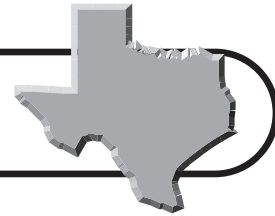

- 36** What is the first step in solving for n in the equation below? **(7.13)(B)**

$$4n + 9 - 5 = -4$$

- F** Add 5 to 4
- G** Subtract 5 from 9
- H** Divide -4 by 4
- J** Multiply -5 by -4

- 37** Which line contains the ordered pair $(-4, -5)$? **(7.7)(A)**

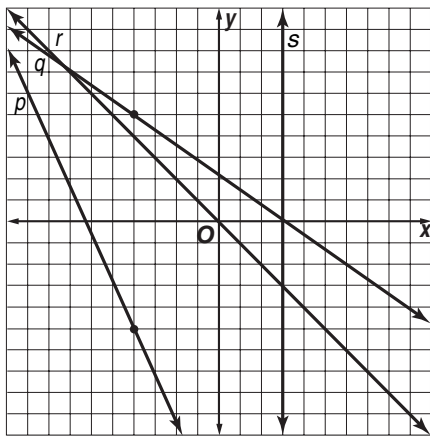

- A** Line p
- B** Line q
- C** Line r
- D** Line s

- 38** Jack made a spinner with five equal-sized sections and colored them red, green, blue, yellow, and purple. What is the probability that the pointer will stop on red or blue? **(7.10)(B)**

- F** $\frac{1}{5}$
- G** $\frac{2}{5}$
- H** $\frac{3}{5}$
- J** $\frac{2}{3}$

- 39** Which best describes two triangles that have equal corresponding angles and proportional corresponding sides? **(7.6)(D)**

- A** congruent
- B** similar
- C** symmetric
- D** regular

- 40** Five eighth-grade math students took a college-level exam. Their scores are given below.

12, 55, 58, 60, 70

Which statistic would make the test scores appear to be much lower than they actually are? **(7.12)(B)**

- F** mean
- G** median
- H** mode
- J** range

- 41** Ms. Moberly compared the prices of 4 different-sized bottles of shampoo.

Size	Price
20 oz	\$2.49
15 oz	\$1.99
12 oz	\$1.59
8 oz	\$1.29

If Ms. Moberly wants to save as much money as possible, what size bottle of shampoo should she buy? **(7.15)(B)**

- A** A 20-ounce bottle, because the shampoo costs the least per ounce.
- B** A 15-ounce bottle, because each ounce of shampoo costs about \$0.13.
- C** A 12-ounce bottle, because she prefers this bottle size.
- D** A 8-ounce bottle, because it costs the least amount of money.



Diagnostic Test (continued)

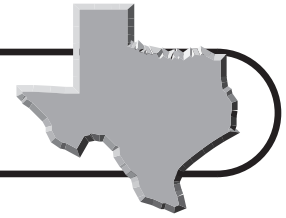

- 42** In 2000, 9.9% of the population of Texas was 65 years of age or older. The population of the state in 2000 was 22,490,022. Estimate the number of Texas residents aged 65 years old or older in 2000. **(7.13)(D)**
- F** 22,000,000 **H** 2,200,000
G 19,800,000 **J** 1,980,000

- 43** An artist is making a stained glass window. The shaded areas in the diagram will be colored blue. What area of the window will be blue? **(7.8)(C)**

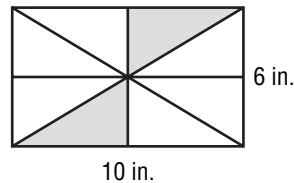

- A** 7.5 in^2 **C** 30 in^2
B 15 in^2 **D** 60 in^2
- 44** Which expression is represented by the model below? **(7.2)(C)**
-
- F** $5 + 8$
G $8 - 5$
H $5 - 8$
J $8 \div 5$
- 45** Caroline ran the 100-yard dash in 14.83 seconds. Tanya ran it in 14.59 seconds. How much faster did Tanya run the dash than did Caroline? **(7.2)(B)**
- A** 0.56 sec
B 0.46 sec
C 0.34 sec
D 0.24 sec
- 46** Which sequence follows the rule $2n^2 + 3$, where n represents the position of a term in the sequence? **(7.4)(C)**
- F** 5, 11, 21, 35, 53, ...
G 5, 7, 9, 11, 13, ...
H 4, 7, 12, 19, 28
J 7, 19, 39, 67, 103, ...
- 47** David painted one wall in his bedroom. The wall was 10 feet long and 8 feet high. It had a door opening that was 3 feet wide and 7 feet high. Which question cannot be answered with the information provided? **(7.13)(A)**
- A** What was the area of the wall that David painted?
B What was the area of the doorway?
C What was the perimeter of the doorway?
D What was the volume of paint David used?
- 48** Mr. Jones is planting grass seed in a small area of his lawn. The area to be seeded is 20 feet long and 16 feet wide. If a bag of grass seed covers between 60 and 80 square feet, what is the least number of bags he will use? **(7.9)**
- F** 2 bags
G 3 bags
H 4 bags
J 5 bags



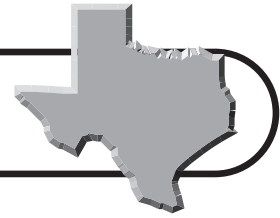

TAKS Practice

OBJECTIVE 1

Read each question and choose the correct answer.

(7.1)(A) Number, operations, and quantitative reasoning The student represents and uses numbers in a variety of equivalent forms. The student is expected to compare and order integers and positive rational numbers.

- Annabeth measured 4 lengths of string for a science experiment. The strings were 8.3 centimeters, 7.1 centimeters, 10.8 centimeters, and 9.6 centimeters. Which list shows the lengths in order from shortest to longest?
 - 7.1, 10.8, 9.6, 8.3
 - 10.8, 9.6, 8.3, 7.1
 - 9.6, 10.8, 7.1, 8.3
 - 7.1, 8.3, 9.6, 10.8
- Keith ate $\frac{5}{8}$ of his personal pizza. Claire ate $\frac{1}{2}$ of hers, Jana ate $\frac{3}{4}$ of hers, and Erik ate $\frac{9}{16}$ of his. Who ate the most of his or her pizza?

F Keith	H Jana
G Claire	J Erik
- Pam recorded the temperature in Dallas over a one-week period. Which set of numbers shows these temperatures in order from warmest to coolest?
 - 65°F, 69°F, 72°F, 73°F, 74°F, 75°F, 76°F
 - 76°F, 75°F, 74°F, 73°F, 72°F, 69°F, 65°F
 - 72°F, 75°F, 69°F, 74°F, 73°F, 76°F, 65°F
 - 76°F, 75°F, 69°F, 72°F, 73°F, 74°F, 65°F
- Which set of rational numbers is in order from least to greatest?
 - 3.2, 4.5, 4.6, -5.8, -9.7
 - 9.7, -5.8, 3.2, 4.5, 4.6, 9.4
 - 3.2, 4.5, 4.6, -5.8, 9.4, -9.7
 - 5.8, -9.7, 3.2, 4.5, 4.6, 9.4

(7.1)(B) Number, operations, and quantitative reasoning The student represents and uses numbers in a variety of equivalent forms. The student is expected to convert between fractions, decimals, whole numbers, and percents mentally, on paper, or with a calculator.

- Jessica completed $\frac{1}{5}$ of her math homework during class. Susannah completed $\frac{3}{10}$ of her homework, Jorge completed $\frac{1}{4}$ of his homework, and Xai completed $\frac{1}{3}$ of his homework. Who completed 30% of his or her math homework during class?

A Jessica	C Jorge
B Susannah	D Xai
- In 2004, 8.4% of the people living in Texas were younger than 5 years old. Which of these numbers is NOT equivalent to 8.4%?

F $\frac{8}{1000}$	H 0.084
G $\frac{8.4}{100}$	J 8.4
- Louisa landscaped $\frac{1}{4}$ of her garden with bluebonnets. What percentage of her garden did she landscape with bluebonnets?

A 20%	C 30%
B 25%	D 35%
- Which list of rational numbers does not show equivalent values?

F $\frac{1}{5}$, 0.2, 20%	H $\frac{1}{40}$, 0.025, 2.5%
G $\frac{1}{10}$, 10.0, 10%	J $\frac{1}{8}$, 0.125, 12.5%

TAKS Practice (continued)

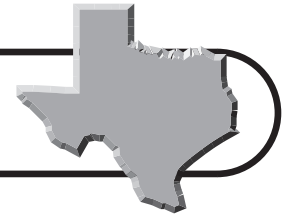

(7.1)(C) Number, operations, and quantitative reasoning The student represents and uses numbers in a variety of equivalent forms. The student is expected to represent squares and square roots using geometric models.

- 1 Which of these equations does the model represent?

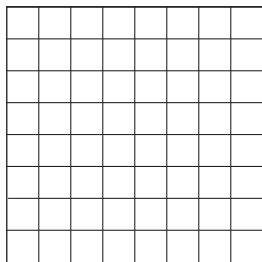

- A $8^2 = 64$
 B $8^2 = 16$
 C $8^8 = 64$
 D $8^2 = 10$

- 2 Which model represents 4^2 ?

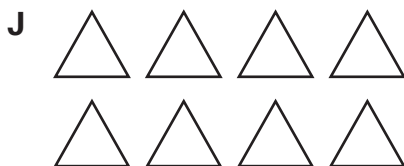
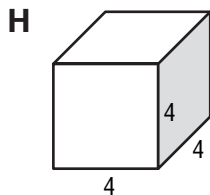
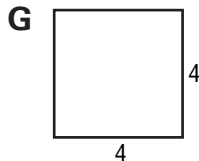
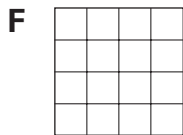

- 3 Which model of squares can be used to show $\sqrt{144}$?

- A 4 rows of 36 squares
 B 3 rows of 48 squares
 C 12 rows of 12 squares
 D 14 rows of 14 squares

- 4 Which model shows 5^2 ?

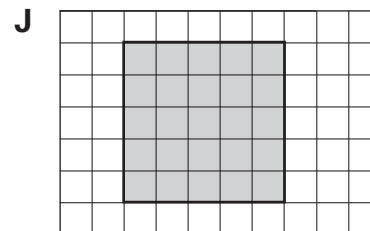
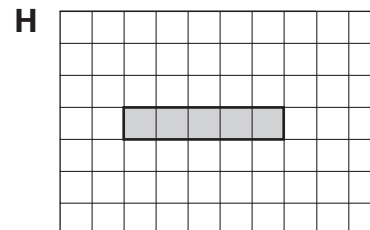
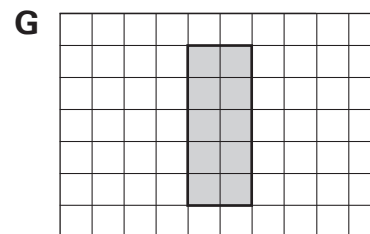
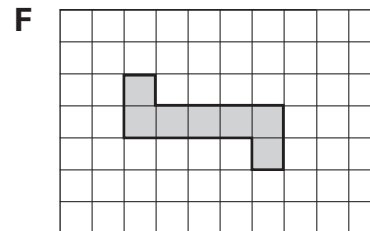

TAKS Practice (continued)

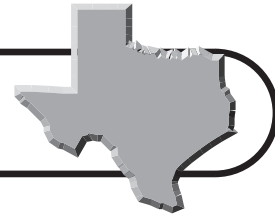

(7.2)(A) Number, operations, and quantitative reasoning The student adds, subtracts, multiplies, or divides to solve problems and justify solutions. The student is expected to represent multiplication and division situations involving fractions and decimals with models, including concrete objects, pictures, words, and numbers.

1 Which model shows $\frac{1}{2} \times \frac{1}{4}$?

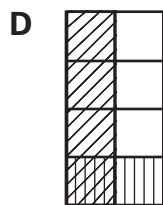
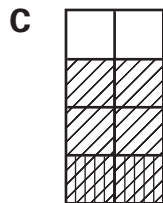
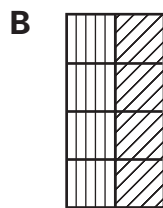
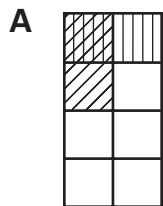

2 Carlo bought $6\frac{1}{2}$ yards of material. He can make one pair of pants from $3\frac{1}{4}$ yards of material. Which expression can he use to find how many pairs of pants he can make with the material?

F $6\frac{1}{2} \div 3\frac{1}{4}$

G $3\frac{1}{4} \div 6\frac{1}{2}$

H $3\frac{1}{4} + 6\frac{1}{2}$

J $6\frac{1}{2} \times 3\frac{1}{4}$

3 Joanna needs 150 beads to make one necklace. One packet of 50 beads costs \$1.29 with tax. Which equation can be used to find C , how much Joanna will spend on beads to make one necklace?

A $C = 50 \times 1.29$

B $C = (150 + 50) \times 1.29$

C $C = (150 \div 50) \times 1.29$

D $C = 150 \times 1.29$

4 Moriah's mother is a baker. She has a 5.4-pound brick of chocolate that she needs to divide into 0.6-pound pieces. Which expression can Moriah's mother use to find how many pieces of chocolate she will have?

F $5.4 \div 0.6$

G 5.4×0.6

H $0.6 + 5.4$

J $0.6 \div 5.4$

TAKS Practice (continued)

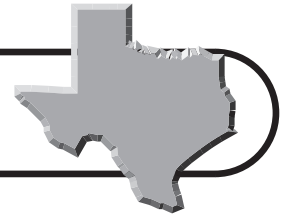

- 5 Jackson had $\frac{2}{3}$ of a chicken potpie in the refrigerator. He ate $\frac{1}{2}$ of it for lunch. Which model shows how much of the pie he ate for lunch?

A

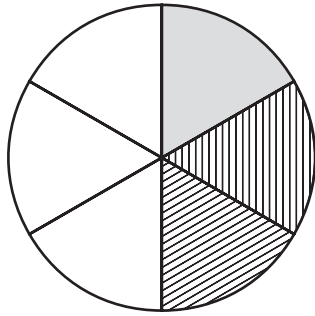

B

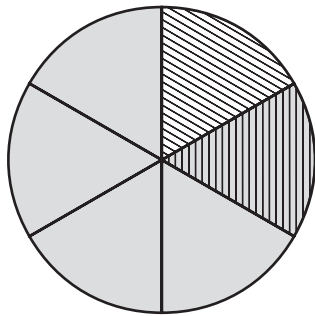

C

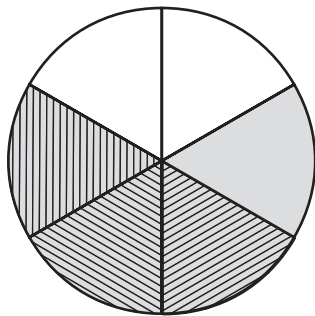

D

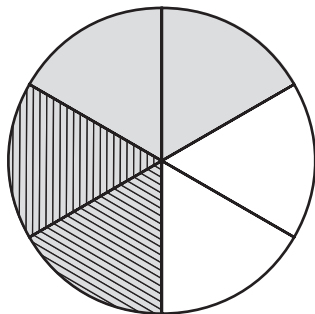

(7.2)(B) Number, operations, and quantitative reasoning The student adds, subtracts, multiplies, or divides to solve problems and justify solutions. The student is expected to use addition, subtraction, multiplication, and division to solve problems involving fractions and decimals.

- 1 Lowell buys a book for \$7.75. The sales tax on the book is 5%. If he pays with a \$10 bill, how much change should he receive?

A \$0.14
 B \$1.86
 C \$7.36
 D \$8.14

- 2 The table below shows the distance Cedric rode on each day of a five-day cycling trip.

Day	Distance (miles)
1	26.5
2	40.2
3	$50\frac{1}{5}$
4	$28\frac{3}{4}$
5	35.5

What was the total distance Cedric cycled on his trip?

F 78.95 mi
 G 102.2 mi
 H 181.15 mi
 J 192.5 mi

TAKS Practice (continued)

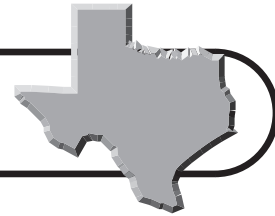

- 3 Lindsey bought a half-bushel of Texas peaches to share among her and three of her friends. What fraction of a full bushel of peaches will each person receive?

A $\frac{1}{8}$
 B $\frac{1}{6}$
 C $\frac{1}{4}$
 D $\frac{1}{2}$

- 4 Kayla wants to join the new gym in her neighborhood. Gym membership is \$45.50 per month, plus a one-time fee of \$34.95. How much is a 6-month gym membership?

F \$270.00
 G \$273.00
 H \$304.95
 J \$307.95

- 5 The park near Amanda's house has a path around its perimeter that is $\frac{3}{4}$ mile. Amanda's goal is to walk $4\frac{1}{2}$ miles a day. How many times must Amanda walk around the park to reach her goal?

A 3
 B 4
 C 6
 D 8

(7.2)(C) Number, operations, and quantitative reasoning The student adds, subtracts, multiplies, or divides to solve problems and justify solutions. The student is expected to use models, such as concrete objects, pictorial models, and number lines, to add, subtract, multiply, and divide integers and connect the actions to algorithms.

- 1 Which expression does the model show?

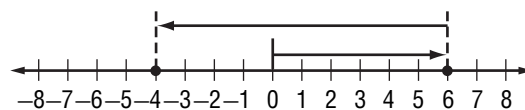

A $10 + 6$
 B $-6 + 10$
 C $10 - 6$
 D $6 - 10$

- 2 What problem does the model show?

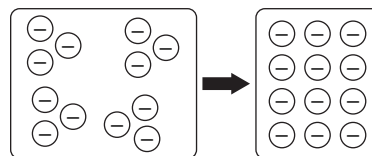

- F Eli had 4 model airplanes. His friend gave him 3 more. How many models does he have in all?
 G Mia gave 4 dollars to each of her three friends. How many dollars does Mia have now?
 H Chase gave 3 granola bars to each of 4 friends. How many granola bars did he give away?
 J Kennedy had 4 extra notebooks in her desk. She gave 3 of them to her sister. How many extra notebooks does she now have?

TAKS Practice (continued)

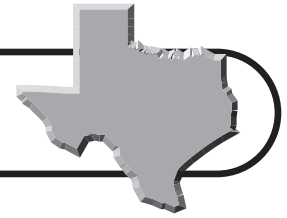

3 Which equation does the model show?

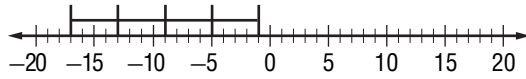

- A $16 \div 4 = -4$
 B $16 \div -4 = 4$
 C $-16 \div 4 = 4$
 D $-16 \div 4 = -4$

4 Which model matches the following problem?

Marta owes her mother \$10. She pays her \$5. How much money does Marta still owe her mother?

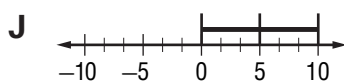
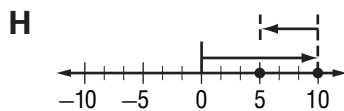
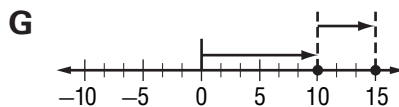
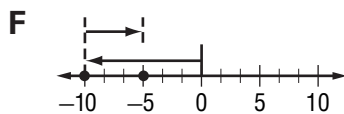

5 Which expression does the model show?

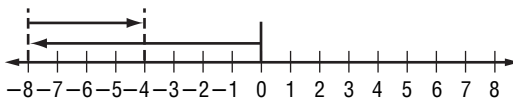

- A $8 - 5$
 B $-8 - 5$
 C $-8 + 5$
 D $8 + 5$

(7.2)(D) Number, operations, and quantitative reasoning The student adds, subtracts, multiplies, or divides to solve problems and justify solutions. The student is expected to use division to find unit rates and ratios in proportional relationships such as speed, density, price, recipes, and student-teacher ratio.

1 A 12-ounce can of soup costs \$0.96. What is the price of the soup per ounce?

- A \$0.11 per oz
 B \$0.08 per oz
 C \$0.05 per oz
 D \$0.03 per oz

2 Ahmed drove the 190-mile trip from Austin to Dallas, Texas. In the first two hours, he drove 130 miles. If Ahmed continues at the same speed, what is the best estimate for how long it will take for him to arrive in Dallas?

- F 2 h
 G 3 h
 H 4 h
 J 5 h

3 One hundred forty seventh graders are going on a field trip to the Johnson Space Center. The ratio of chaperones to students must be 1:10. How many chaperones are needed for the trip?

- A 12
 B 13
 C 14
 D 15

TAKS Practice (continued)

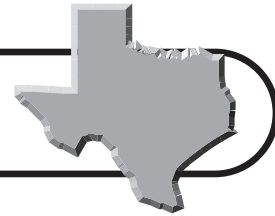

- 4 Abby is making some blueberry muffins.

The recipe calls for $1\frac{1}{2}$ cups of flour for 3 dozen muffins. How much flour does Abby need if she wants to make 1 dozen muffins?

F $1\frac{1}{4}$ cups

G 1 cup

H $\frac{3}{4}$ cup

J $\frac{1}{2}$ cup

- 5 The human heart beats an average of 4,320 times in 1 hour. How many times does the heart beat in 1 minute?

A 46

B 52

C 60

D 72

- 6 Jesse researched his hometown and learned that the population of the town is 13,932. He also found that the town covers 516 square miles. What is the population of Jesse's town per square mile?

F 27

G 72

H 129

J 258

(7.2)(E) Number, operations, and quantitative reasoning The student adds, subtracts, multiplies, or divides to solve problems and justify solutions. The student is expected to simplify numerical expressions involving order of operations and exponents.

- 1 What is the value of $8 \times (8 + 3) \div 2^2$?

A 22

C 16

B 17

D 6

- 2 Simplify $5^2 + 6(-10 + 4)$.

F 61

H -11

G 11

J -61

- 3 What is the value of $4(9 - 2) \div 2^2 + 3$?

A 4

C 8

B 5

D 10

- 4 What is the value of $5^2(3 - 4 \times 2)$?

F -125

H 50

G -50

J 125

- 5 Simplify $8^2 + 10 \div 2 \times 3$.

Record your answer and fill in the bubbles on the grid below. Be sure to use the correct place value.

0	0	0	0	.	0	0
1	1	1	1		1	1
2	2	2	2		2	2
3	3	3	3		3	3
4	4	4	4		4	4
5	5	5	5		5	5
6	6	6	6		6	6
7	7	7	7		7	7
8	8	8	8		8	8
9	9	9	9		9	9

TAKS Practice (continued)

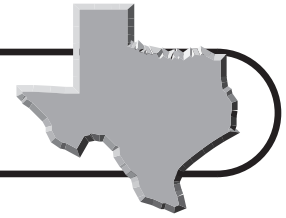

(7.2)(F) Number, operations, and quantitative reasoning The student adds, subtracts, multiplies, or divides to solve problems and justify solutions. The student is expected to select and use appropriate operations to solve problems and justify the selections.

1 Janine spent \$21.28 on groceries. She bought a wedge of cheese for \$5.29, eggs for \$1.05, bread for \$2.49, and some gallons of milk at \$2.49 a gallon. How many gallons of milk did she buy?

- A** 3
- B** 4
- C** 5
- D** 6

2 Charlie has invited 25 friends to his birthday party. He wants to buy party favors, which come in packages of 4. Charlie determines that he needs to buy 7 packages of favors and will have 3 favors left. Which equations shows that Charlie is correct?

- F** $4 \times 7 = 28$; $28 - 25 = 3$
- G** $25 - 4 = 21$; $21 \div 7 = 3$
- H** $24 \div 4 = 6$; $6 - 3 = 3$
- J** $24 \div 2 = 12$; $12 \div 4 = 3$

3 On Wednesday, 132 students bought hot lunches at school. Each lunch came with 2 cookies for dessert. Which operations can you use to find how many dozen cookies were served with hot lunches on Wednesday?

- A** Addition and division
- B** Multiplication and division
- C** Multiplication and subtraction
- D** Division and subtraction

4 Sydney bought 5 new notebooks for \$1.35 each and 12 pens that cost 3 for \$1.25. What is the total amount she spent, not including tax, on notebooks and pens?

- F** \$8.00
- G** \$10.50
- H** \$11.35
- J** \$11.75

5 Sherry's health club charges a monthly membership fee of \$42.00. She paid a one-time membership fee of \$25.00 when she joined the club. If Sherry has paid a total of \$361.00, for how many months has she been a member?

- A** 6
- B** 7
- C** 8
- D** 9

6 Tim can complete 3 math problems in 10 minutes. How many problems can Tim complete in $\frac{1}{2}$ hour?

- F** 6
- G** 9
- H** 12
- J** 20

7 Grace made 35 bracelets to sell at a craft fair. If she sells all 35 of the bracelets at a price of \$2.75 each, how much money will she earn?

- A** \$12.73
- B** \$37.75
- C** \$72.75
- D** \$96.25

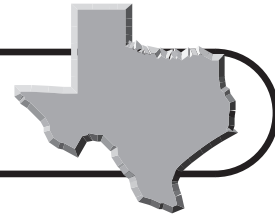

TAKS Practice

OBJECTIVE 2

Read each question and choose the correct answer.

(7.2)(G) Number, operations, and quantitative reasoning The student adds, subtracts, multiplies, or divides to solve problems and justify solutions. The student is expected to determine the reasonableness of a solution to a problem.

- 1 In 2000, about 1 in 20 people in Austin County was 5 years old or younger. There were 28,500 people living in Austin County. Jeremy wants to determine how many people in Austin County are 5 years or younger. Which is a reasonable solution to Jeremy's problem?
A 140
B 1400
C 14,000
D 140,000
- 2 Shaney uses between $1\frac{1}{2}$ and $1\frac{3}{4}$ cups of flour to make dough for one pizza crust. If she uses $14\frac{1}{2}$ cups of flour, what is a reasonable number of pizza crusts she can make?
F 7
G 8
H 9
J 10
- 3 Micha's father bought 0.75 pound of dried pears that were on sale for \$2.99 per pound. Micah thinks his father spent \$2.00 for the pears. Is his answer reasonable?
A No, 75% of \$3.00 is \$1.00.
B No, 75% of \$3.00 is \$2.25.
C Yes, 75% of \$3.00 is \$2.00.
D No, 75% of \$3.00 is \$2.50.

(7.3)(A) Patterns, relationships, and algebraic thinking The student solves problems involving proportional relationships. The student is expected to estimate and find solutions to application problems involving percent.

- 1 Tyler completed 12 of his 30 history questions before dinner. What percentage of the questions are left for Tyler to complete?
A 20%
B 40%
C 60%
D 80%
- 2 According to a survey, 33 out of 120 seventh-graders at Monroe Middle School play an instrument in the school band. What percentage of the seventh grade students at Monroe Middle School play in the school band?
F 27.5%
G 33.3%
H 37.5%
J 43.3%
- 3 The West Middle School Math Club has 15 sixth-grade members, 12 seventh-grade members, and 13 eighth-grade members. What percentage of the math club members are either sixth or seventh graders?
A 30%
B 32.5%
C 67.5%
D 72%

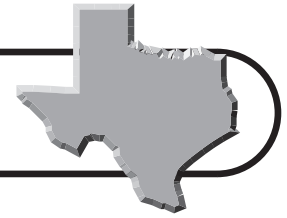

TAKS Practice (continued)

- 4** In 2003, the population of Amarillo was 178,612. Also in 2003, 20.5% of the population of Amarillo had a college education. What is a reasonable estimate of how many people in Amarillo had a college education in 2003?

F 35,000
G 37,000
H 37,500
J 38,000

- 5** Franklin surveyed his classmates at Shepherd Middle School and found that 74% of students surveyed responded that they would like an extra 5 minutes of lunchtime. If 150 students were surveyed, about how many students would respond that they would not want an extra 5 minutes of lunchtime?

A 39
B 74
C 76
D 111

- 6** Madison is hoping to buy a new pair of sneakers that cost \$89.75. One week, the sneakers go on sale for 20% off. About how much will Madison save if she buys the sneakers on sale?

F \$9.00
G \$12.50
H \$15.75
J \$18.00

(7.3)(B) Patterns, relationships, and algebraic thinking The student solves problems involving proportional relationships. The student is expected to estimate and find solutions to application problems involving proportional relationships such as similarity, scaling, unit costs, and related measurement units.

- 1** The prices of 3 different packages of eggs are given in the table.

Package Size (doz)	Price
$\frac{1}{2}$	\$.60
1	\$.98
$1\frac{1}{2}$	\$1.25

Which package of eggs has the lowest price per egg?

- A** The package of $1\frac{1}{2}$ dozen eggs.
B The package of 1 dozen eggs.
C The package of $\frac{1}{2}$ dozen eggs.
D The package of 1 dozen eggs and the package of $1\frac{1}{2}$ dozen eggs.
- 2** The distance between Abilene and Odessa is 168 miles. The scale on a map of Texas is 1 inch equals 30 miles. How many inches separate Abilene from Odessa on the map?
- F** 1.7 in. **H** 5.1 in.
G 2.8 in. **J** 5.6 in.
- 3** Travis is creating a scale drawing of his living room to explore ways to arrange his furniture. The actual size of his sofa is 78 inches long and 36 inches wide. If the scale drawing is 1 to 12 inches, how long will the sofa be on the drawing?
- A** 1.5 in. **C** 6.5 in.
B 5.6 in. **D** 7.2 in.

TAKS Practice (continued)

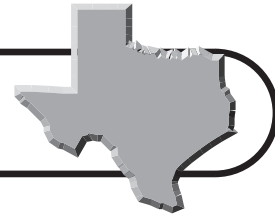

- 4** A 3-pound bag of oranges costs \$3.57. If the cost per pound is the same for a 5-pound bag of oranges, what is the cost of the 5-pound bag?
- F** \$3.57
G \$5.95
H \$10.71
J \$17.85

- 5** A 12-ounce can of peaches costs \$1.38. What is the unit cost of the can of peaches?
- A** \$0.10/oz
B \$0.105/oz
C \$0.11/oz
D \$0.115/oz

- 6** An interior designer made a scale drawing of a living room. The scale of the drawing is 1:50. Use the ruler provided in the Mathematics Chart to measure the length of the table to the nearest centimeter. What is a good estimate of the length of the actual table?

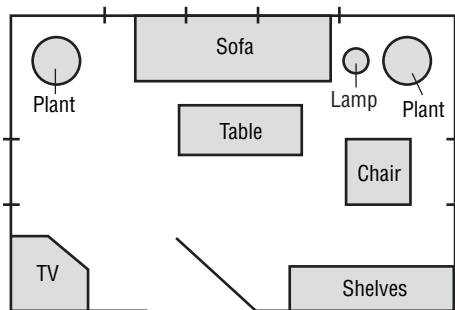

- F** 43 cm
G 95 cm
H 148 cm
J 500 cm

- 7** JoAnn can run the first 50 meters of the 200-meter race in 6.3 seconds. If she can maintain the same speed for the whole race, about how many seconds will it take for JoAnn to finish the race?

Record your answer and fill in the bubbles on the grid below. Be sure to use the correct place value.

				.		
0	0	0	0		0	0
1	1	1	1		1	1
2	2	2	2		2	2
3	3	3	3		3	3
4	4	4	4		4	4
5	5	5	5		5	5
6	6	6	6		6	6
7	7	7	7		7	7
8	8	8	8		8	8
9	9	9	9		9	9

- 8** $\triangle ABC$ is similar to $\triangle JKL$. What is the length of \overline{JK} ?

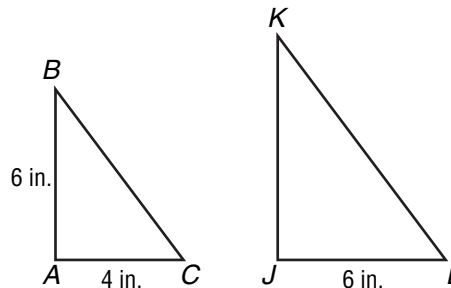

- A** 4 in.
B 6 in.
C 7 in.
D 9 in.

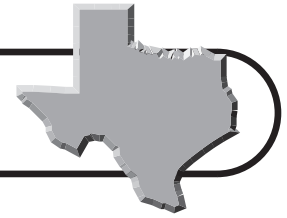

TAKS Practice (continued)

(7.4)(A) Patterns, relationships, and algebraic thinking The student represents a relationship in numerical, geometric, verbal, and symbolic form. The student is expected to generate formulas involving unit conversions, perimeter, area, circumference, volume, and scaling.

- 1** A cattle rancher is replacing the fence around a square area of pasture that measures 1,249 meters on a side. Which of the following formulas CANNOT be used to find how many meters of fencing the rancher is replacing?

A $4s$
B $s \times s$
C $2s + 2s$
D $s + s + s + s$

- 2** Atticus works at a pizza parlor. He uses 2 cups of cheese on every 14-inch pizza. Which of the following expressions can he use to calculate the area of a 14-inch pizza?

F $\pi(7)$
G $\pi^2 7$
H $\pi(7)^2$
J $\frac{7}{\pi^2}$

- 3** Bryan is making a lampshade. The diameter of the top of the shade is 15 centimeters. Which of the following can he use to find the circumference of the top of the lampshade?

A 15π
B 30π
C 56.25π
D 225π

- 4** The distance on a map between Del Rio and Odessa is 8.5 inches. The scale of the map is 1 inch = 30 miles. Which of these formulas cannot be used to find the actual distance d , between Del Rio and Odessa?

F $\frac{8.5}{30} = \frac{d}{1}$
G $\frac{8.5}{d} = \frac{1}{30}$
H $\frac{1}{8.5} = \frac{30}{d}$
J $\frac{d}{8.5} = \frac{30}{1}$

- 5** Ezra is setting up a new fish tank. The tank is 100 centimeters long, 67 centimeters wide, and 52 centimeters tall. Which of the following expressions can he use to estimate the volume of the fish tank?

A $100 + 70 + 50$
B $100 \times 70 \times 50$
C $100 + 67 + 52$
D $100 \times 67 \times 52$

- 6** LaDawn has 5 yards of ribbon that she needs to cut into 9-inch pieces. Which expression can she use to find how many 9-inch pieces she will have?

F $(50 - 12) \times 9$
G $(50 - 36) \times 9$
H $\frac{50 \times 12}{9}$
J $\frac{5 \times 36}{9}$

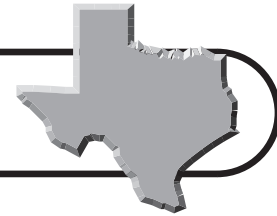

TAKS Practice (continued)

(7.4)(B) Patterns, relationships, and algebraic thinking The student represents a relationship in numerical, geometric, verbal, and symbolic form. The student is expected to graph data to demonstrate relationships in familiar concepts such as conversions, perimeter, area, circumference, volume, and scaling.

1 Which of the following relationships matches the data in the graph?

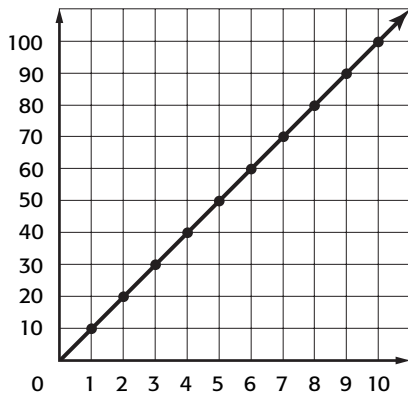

- A Liters to milliliters
- B Kilograms to grams
- C Meters to millimeters
- D Centimeters to millimeters

2 Which of the following relationships matches the data in the graph?

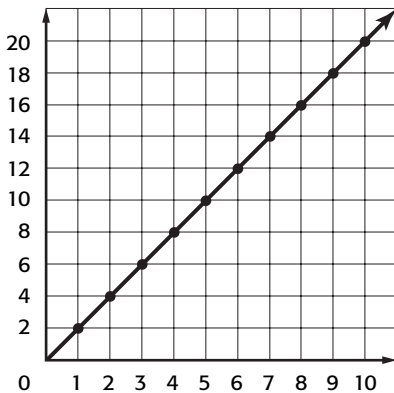

- F side length to perimeter
- G side length to area
- H side length to volume
- J side length to height

3 Which of the following graphs matches the data in the table?

Length of Side (in.)	Perimeter (cm)
1	4
2	8
3	12
4	16

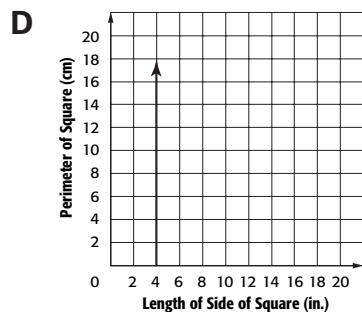
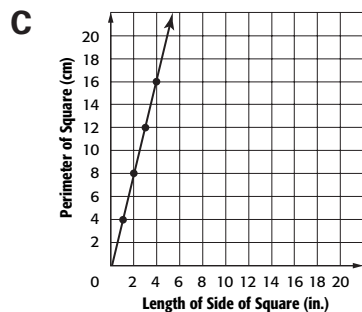
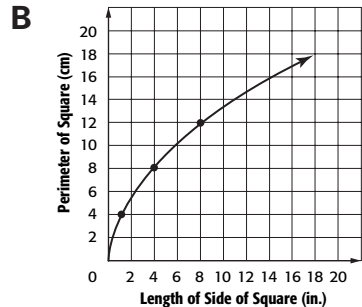
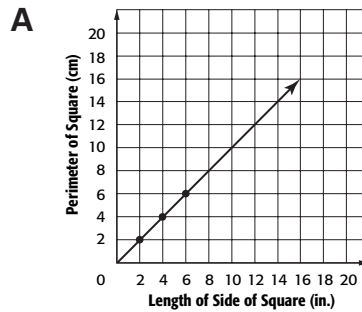

TAKS Practice (continued)

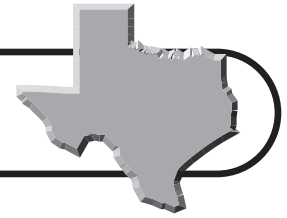

- 4 Which graph matches the data in the table?

Side length (cm)	Volume (cm ³)
1	1
2	8
3	27
4	64

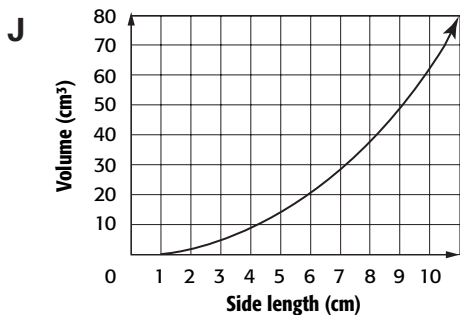
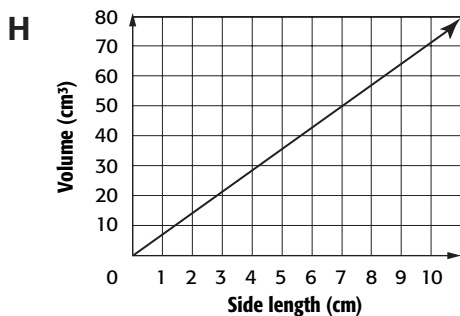
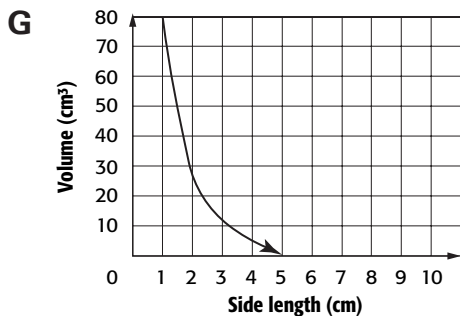
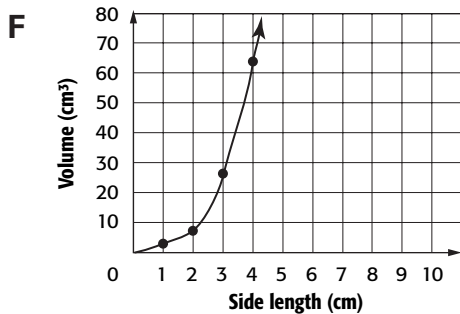

(7.4)(C) Patterns, relationships, and algebraic thinking

The student represents a relationship in numerical, geometric, verbal, and symbolic form. The student is expected to use words and symbols to describe the relationship between the terms in an arithmetic sequence (with a constant rate of change) and their positions in the sequence.

- 1 Which rule can be used to find the value of a term in the n th position in the sequence shown in the table below?

Position	Term
1	4
2	8
3	12
4	16
5	20

- A** Multiply the position number by 2.
B Multiply the position number by 4.
C Square the position number.
D Cube the position number.

- 2 Every third day it is Raheem's turn to empty the dishwasher and to set the table. If he empties the dishwasher and sets the table on the first of the month, what expression can be used to find the n th day of the month he will do these chores?

- F** $n + 3$
G $n - 3$
H $3n$
J n^3

- 3 Which sequence follows the rule $n^2 + 4$, where n represents the position of a term in the sequence?

- A** 6, 8, 10, 12, 14, ...
B 5, 8, 11, 14, 17, ...
C 6, 10, 14, 18, 22, ...
D 5, 8, 13, 20, 29, ...

TAKS Practice (continued)

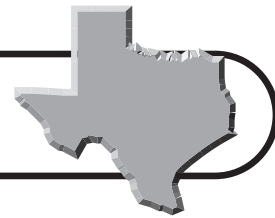

- 4 Which expression can be used to find the 5th term in the sequence shown?

0.1, 0.2, 0.3, 0.4, ...

- F** $5 + 0.1$
G $5 - 0.1$
H 5×0.1
J $5 \div 0.1$

- 5 Which rule shows the relationship between a term and n , its position in the sequence?

Position	Term
1	1
2	3
3	5
4	7
n	

- A** Multiply n by 2 and then subtract 2.
B Multiply n by 1 and then add 2.
C Multiply n by 2 and then subtract 1.
D Multiply n by 3 and then subtract 2.
- 6 Marta's exercise routine includes jogging, swimming, and cycling. She jogs one day, swims the next, rides her bike on the third day, and rests on the fourth day. Which expression can be used to find the n th day that Marta will be jogging?

- F** $n + 4$
G $n - 4$
H $n \div 4$
J $n \times 4$

(7.5)(A) Patterns, relationships, and algebraic thinking

The student uses equations to solve problems. The student is expected to use concrete and pictorial models to solve equations and use symbols to record the actions.

- 1 The model shows the equation $3x + 6 = 2y + 6$. Which of these values of x is the solution when $y = 1$?

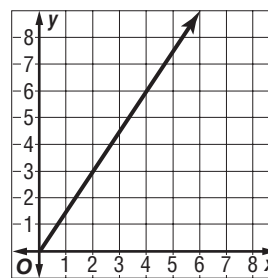

- A** $x = -\frac{3}{2}$ **C** $x = \frac{2}{3}$
B $x = -\frac{2}{3}$ **D** $x = \frac{3}{2}$

- 2 The model below represents the equation $4x + 8 = 2y$.

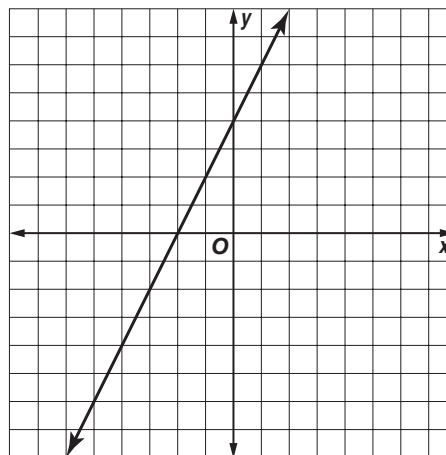

What is the solution to the equation when $y = 6$?

- F** $x = 4$ **H** $x = 1$
G $x = 2$ **J** $x = -1$

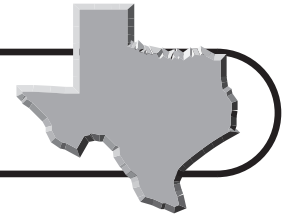

TAKS Practice (continued)

- 3** Using the model, what is the solution to the equation $2x = -16$?

$$\begin{array}{|c|} \hline x \\ \hline \end{array} \begin{array}{|c|} \hline x \\ \hline \end{array} = \begin{array}{|c|c|c|c|} \hline -1 & -1 & -1 & -1 \\ \hline -1 & -1 & -1 & -1 \\ \hline -1 & -1 & -1 & -1 \\ \hline -1 & -1 & -1 & -1 \\ \hline \end{array}$$

- A** $x = -2$ **C** $x = -8$
B $x = -4$ **D** $x = -18$

- 4** The equation $4x + 3 = 6$ is modeled below.

$$\begin{array}{|c|} \hline x \\ \hline \end{array} \begin{array}{|c|} \hline x \\ \hline \end{array} \begin{array}{|c|} \hline 1 \\ \hline \end{array} \begin{array}{|c|} \hline 1 \\ \hline \end{array} \begin{array}{|c|} \hline 1 \\ \hline \end{array} = \begin{array}{|c|c|c|} \hline 1 & 1 & 1 \\ \hline 1 & 1 & 1 \\ \hline \end{array}$$

$$\begin{array}{|c|} \hline x \\ \hline \end{array} \begin{array}{|c|} \hline x \\ \hline \end{array}$$

What is the solution to the equation?

- F** $x = 1$ **H** $x = \frac{1}{2}$
G $x = \frac{3}{4}$ **J** $x = \frac{1}{4}$

- 5** Haley and her two friends are playing a card game with 20 cards that need to be divided equally among the three. The equation shown by the model can be used to find x , the number of cards each person receives. How many cards does each person receive?

$$\begin{array}{|c|c|c|c|} \hline 1 & 1 & 1 & 1 \\ \hline 1 & 1 & 1 & 1 \\ \hline 1 & 1 & 1 & 1 \\ \hline 1 & 1 & 1 & 1 \\ \hline 1 & 1 & 1 & 1 \\ \hline \end{array} = \begin{array}{|c|c|} \hline 1 & 1 \\ \hline 1 & 1 \\ \hline 1 & 1 \\ \hline \end{array} \begin{array}{|c|c|} \hline 1 & 1 \\ \hline 1 & 1 \\ \hline 1 & 1 \\ \hline \end{array} \begin{array}{|c|c|} \hline 1 & 1 \\ \hline 1 & 1 \\ \hline 1 & 1 \\ \hline \end{array} \begin{array}{|c|} \hline 1 \\ \hline 1 \\ \hline \end{array}$$

$$\begin{array}{|c|} \hline x \\ \hline \end{array} \begin{array}{|c|} \hline x \\ \hline \end{array} \begin{array}{|c|} \hline x \\ \hline \end{array} \begin{array}{|c|} \hline x \\ \hline \end{array} \begin{array}{|c|} \hline x \\ \hline \end{array} \begin{array}{|c|} \hline x \\ \hline \end{array}$$

- A** 5 **C** 7
B 6 **D** 8

(7.5)(B) Patterns, relationships, and algebraic thinking The student uses equations to solve problems. The student is expected to formulate problem situations when given a simple equation and formulate an equation when given a problem situation.

- 1** Which situation matches the equation shown?

$$0.31x = 48,415$$

- A** 48,415 people in Texas were younger than 5 years old in 2000. 31% of these were under 1 year old. What is x , the number of children under 1 year old in 2000?
B Casey made \$48,415 in one year. What is x , the amount of money he made in one month?
C 48,415, or 31%, of the people living in Brownsville were born in another country. What is x , the number of people that live in Brownsville?
D Tyra bought a new car for \$48,415. What is x , the amount of sales tax paid on her purchase?

- 2** Which question can the equation $n = 12 \times 12 \times 15$ answer?

- F** What is the area of a triangle that has a base of 12 centimeters and height of 15 centimeters?
G What is the volume of a rectangular prism that has a length of 12 centimeters, a width of 12 centimeters, and a height of 15 centimeters?
H What is the perimeter of a triangle that has sides of 12 centimeters, 12 centimeters, and 15 centimeters?
J What is the surface area of a triangular prism that has a height of 12 centimeters, a length of 12 centimeters, and a width of 15 centimeters?

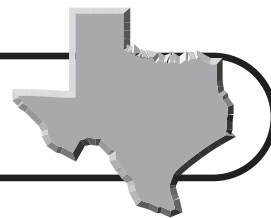

TAKS Practice

OBJECTIVE 3

- 3 Which question can this equation answer?

$$x = \frac{75 + 80 + 92}{3}$$

- A What was Mani's mean test score on her three science tests?
- B How much did Mani improve on each of her three science tests?
- C How many hours did Mani spend studying for each test?
- D What is the difference in scores among Mani's three tests?

- 4 Which problem situation matches this equation?

$$w = 52y$$

- F What is w , the number of weeks in y years?
- G What is w , the area of a square with sides of 52 units?
- H What is w , the number of weeks in y months?
- J What is w , the volume of a cylinder with a radius of 52 and a height of y ?

- 5 Which problem situation matches the equation below?

$$x = 20 - 2(7.5)$$

- A Talia buys movie tickets for \$7.50 each. What is x , the cost of 20 movie tickets?
- B Liko buys two pairs of socks for \$7.50 each. What is x , the cost of 20 pairs of socks at \$7.50 a pair?
- C Sheila buys two shirts for \$7.50 each. What is x , the amount of change she receives when she pays with a twenty-dollar bill?
- D Dimitri buys tickets to a play for \$7.50 each. What is x , the number of tickets he can purchase for exactly \$20.00?

Read each question and choose the correct answer.

(7.6)(A) Geometry and spatial

reasoning The student compares and classifies two- and three-dimensional figures using geometric vocabulary and properties. The student is expected to use angle measurements to classify pairs of angles as complementary or supplementary.

- 1 $\angle J$ and $\angle K$ are complementary angles. If $\angle J = 40^\circ$, what is the measure of $\angle K$?
- A 40°
 - B 50°
 - C 90°
 - D 140°

- 2 Use the diagram below.

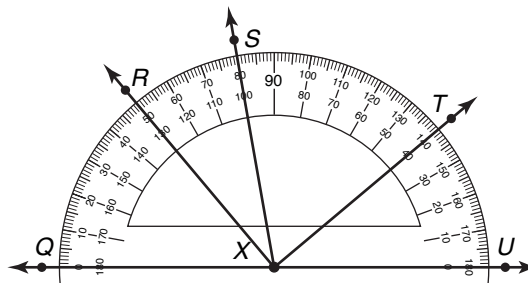

Which pair of angles are complementary angles?

- F $\angle QXS$ and $\angle SXT$
 - G $\angle QXR$ and $\angle RXS$
 - H $\angle TXU$ and $\angle SXT$
 - J $\angle QXR$ and $\angle TXU$
- 3 $\angle P$ and $\angle Q$ are supplementary angles. If $\angle P = 127^\circ$, what is the measure of $\angle Q$?
- A 37°
 - B 53°
 - C 74°
 - D 127°

TAKS Practice (continued)

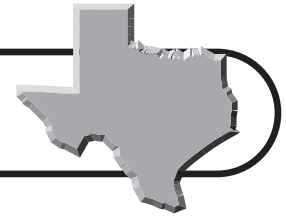

- 4 In the diagram below, which two angles are not supplementary?

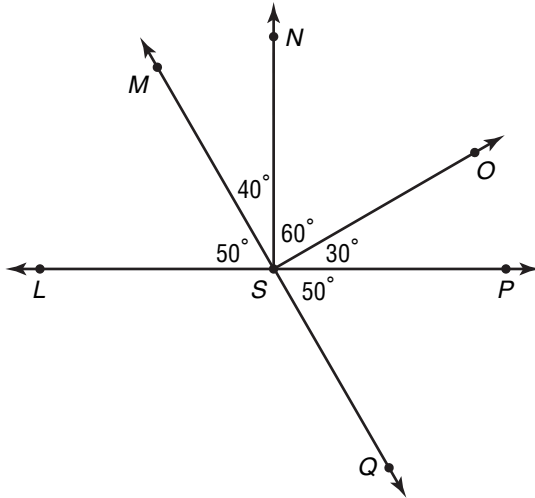

- F $\angle OSP$ and $\angle PSQ$
 G $\angle MSO$ and $\angle OSQ$
 H $\angle LSN$ and $\angle NSP$
 J $\angle LSQ$ and $\angle PSQ$

- 5 Derek is constructing a wood picture frame. He has cut a 45° angle at the end of one piece of the frame. He needs to cut an angle that is complementary to 45° in another part of the frame. What will the measure of this angle be in degrees?

Record your answer and fill in the bubbles on the grid below. Be sure to use the correct place value.

				.		
0	0	0	0		0	0
1	1	1	1		1	1
2	2	2	2		2	2
3	3	3	3		3	3
4	4	4	4		4	4
5	5	5	5		5	5
6	6	6	6		6	6
7	7	7	7		7	7
8	8	8	8		8	8
9	9	9	9		9	9

(7.6)(B) Geometry and spatial reasoning The student compares and classifies two- and three-dimensional figures using geometric vocabulary and properties. The student is expected to use properties to classify triangles and quadrilaterals.

- 1 Which statement is always true of an isosceles triangles?

- A It has 3 congruent angles.
 B The sum of its angles is 180° .
 C It has exactly 3 congruent sides.
 D The sum of any 2 angles is 180° .

- 2 Lorenzo drew the quadrilateral below as part of a design for a T-shirt. Which statement best describes the quadrilateral?

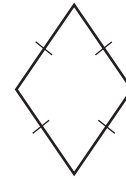

- F It is a trapezoid.
 G It is a parallelogram.
 H It is a rhombus.
 J It is a square.

- 3 Which statement is always true of an equilateral triangle?

- A It has exactly 2 congruent angles.
 B It has 1 right angle.
 C The sum of any two angles is 180° .
 D It has exactly 3 congruent sides.

TAKS Practice (continued)

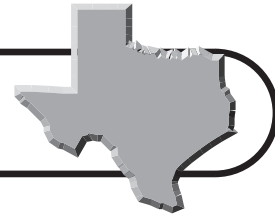

- 4 A soldier folded a United States flag in the shape of a triangle.

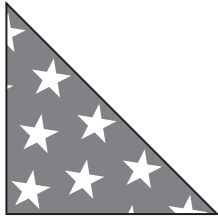

Which of the following best describes the triangle?

- F Right isosceles triangle
 - G Right scalene triangle
 - H Equilateral triangle
 - J Not here
- 5 Which statement is always true of a trapezoid?
- A It has 2 parallel sides.
 - B It has 4 congruent angles.
 - C It has 2 sets of parallel sides.
 - D It has 4 congruent sides.
- 6 Maya noticed that an old house had the following shape.



Which statement best describes the shape of the house?

- F It is a square.
- G It is a rectangle.
- H It is a trapezoid.
- J It is a parallelogram.

(7.6)(C) Geometry and spatial reasoning The student compares and classifies two- and three-dimensional figures using geometric vocabulary and properties. The student is expected to use properties to classify two- and three-dimensional figures, including pyramids, cones, prisms, and cylinders.

- 1 A company is designing a new board game and wants to have place markers that have 1 base and 4 triangular sides. Which solid will the company use for the place markers in the new game?
 - A Triangular pyramid
 - B Square pyramid
 - C Triangular prism
 - D Square prism
- 2 Which of the following attributes does a cone have?
 - F congruent lateral sides
 - G two parallel bases
 - H exactly 1 base
 - J exactly 3 lateral sides
- 3 Sofia made a solid with 2 bases and 3 congruent sides. Which solid did she make?
 - A Pentagonal pyramid
 - B Pentagonal prism
 - C Triangular pyramid
 - D Triangular prism
- 4 Which of the following attributes does a cylinder have?
 - F Exactly one circular base
 - G Two congruent bases
 - H Three congruent faces
 - J Lateral faces that meet at a vertex

TAKS Practice (continued)

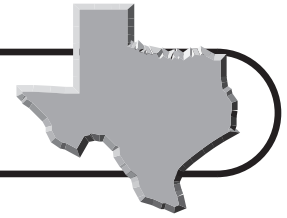

(7.6)(D) Geometry and spatial reasoning

The student compares and classifies two- and three-dimensional figures using geometric vocabulary and properties. The student is expected to use critical attributes to define similarity.

- 1 Which of the following is true of similar figures?
- A Similar figures always have the same size.
 - B Similar figures always have the same shape.
 - C Similar figures always have corresponding sides that are congruent.
 - D Similar figures always have corresponding angles that are proportional.

- 2 Which triangle is similar to $\triangle XYZ$?

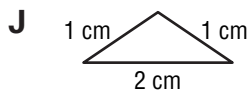
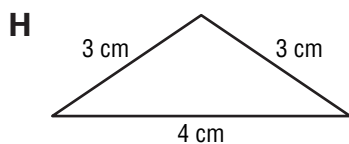
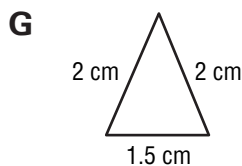
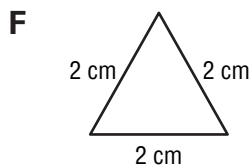
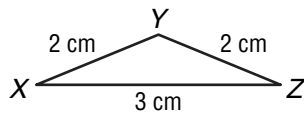

- 3 These two quadrilaterals have congruent angles and proportional sides. Which statement is true about the two quadrilaterals?

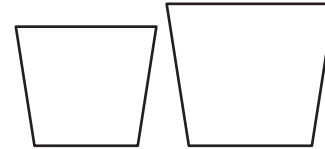

- A They are similar.
 - B They are congruent.
 - C They are symmetric.
 - D They are regular.
- 4 In two similar polygons, what is true about the lengths of the corresponding sides?
- F They are always proportional.
 - G They are always congruent.
 - H They are always symmetric.
 - J They are always parallel.

5. Triangle ABC is similar to triangle DEF . What is the measure of $\angle E$?

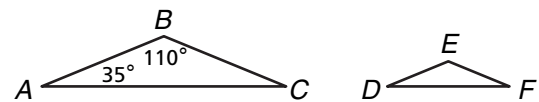

- A 35°
- B 70°
- C 110°
- D 145°

TAKS Practice (continued)

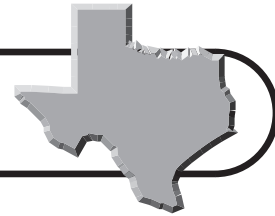

(7.7)(A) Geometry and spatial reasoning

The student uses coordinate geometry to describe location on a plane. The student is expected to locate and name points on a coordinate plane using ordered pairs of integers.

Use this graph to answer Exercises 1–3.

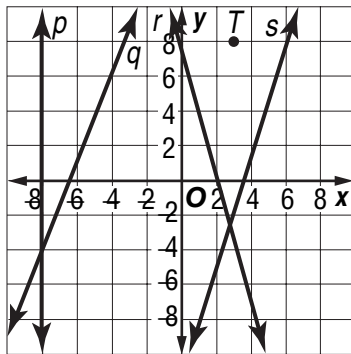

- Which line contains the ordered pair $(-5, 4)$?
A Line p
B Line q
C Line r
D Line s
- What are the coordinates for point T ?
F $(3, 8)$
G $(8, 3)$
H $(-3, 8)$
J $(-8, 3)$
- Which line contains the ordered pair $(4, -7)$?
A Line p
B Line q
C Line r
D Line s

Use the coordinate grid to answer Exercises 4–5.

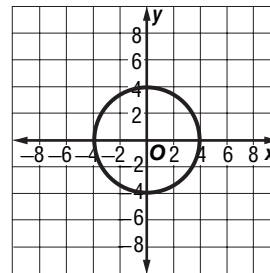

- Which of the following coordinates is not located within the graphed circle?
F $(-3, 2)$
G $(0, -3)$
H $(2, -4)$
J $(1, 2)$
- Which of the following coordinates indicates where circle O crosses the y -axis?
A $(4, 0)$
B $(-4, 0)$
C $(0, 4)$
D $(0, 0)$

TAKS Practice (continued)

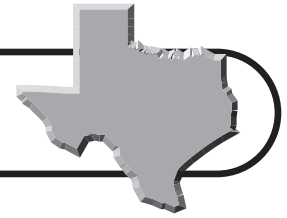

(7.7)(B) Geometry and spatial reasoning

The student uses coordinate geometry to describe location on a plane. The student is expected to graph reflections across the horizontal or vertical axis and graph translations on a coordinate plane.

- 1 Which of these shows a translation of figure B ?

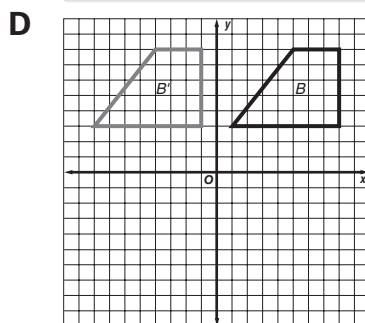
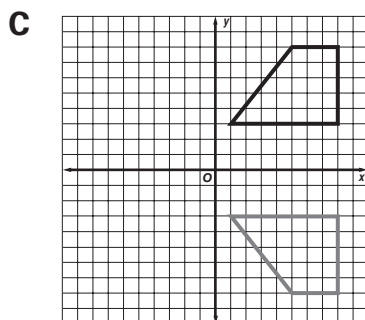
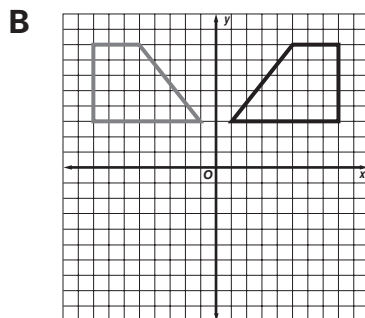
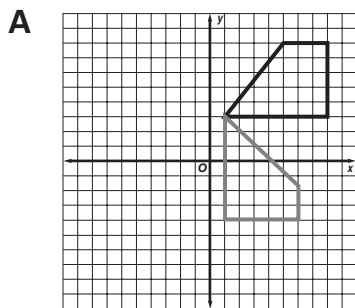

- 2 $\triangle DEF$ is a translation of $\triangle ABC$.

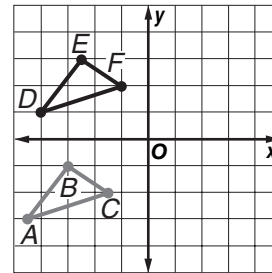

Which of the following describes the translation?

- F** 1 unit to the left and 8 units down
G 8 units to the left and 1 unit up
H 8 units up and 1 unit to the left
J 1 unit to the right and 8 units up

- 3 The figure below was transformed from Quadrant I to Quadrant IV.

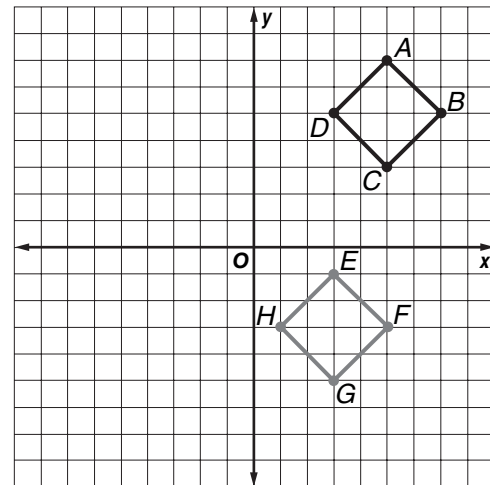

This transformation represents a —

- A** reflection.
B rotation.
C translation.
D tessellation.

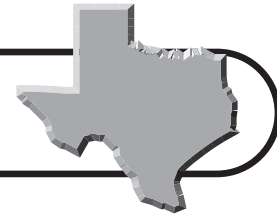

TAKS Practice (continued)

Use the coordinate grid for Exercises 4–5. $\triangle XYZ$ is a translation of $\triangle RST$.

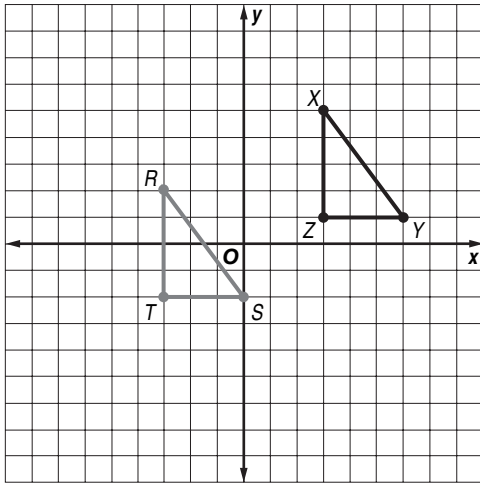

- 4 Which of the following describes the translation?
- F 6 units down and 3 units to the left
 - G 6 units to the left and 3 units down
 - H 6 units to the left and 1 unit down
 - J 3 units down and 1 unit to the left
- 5 What would be the coordinates of X' if $\triangle X'Y'Z'$ is across the x -axis?
- A (3, -5)
 - B (-3, 5)
 - C (-3, -5)
 - D (3, 5)

(7.8)(A) Geometry and spatial reasoning

The student uses geometry to model and describe the physical world. The student is expected to sketch three-dimensional figures when given the top, side, and front views.

- 1 Rose built a solid figure with cubes. The top, side, and front views of the figure are shown below.

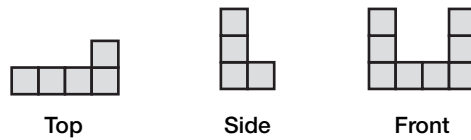

Which solid figure matches these views?

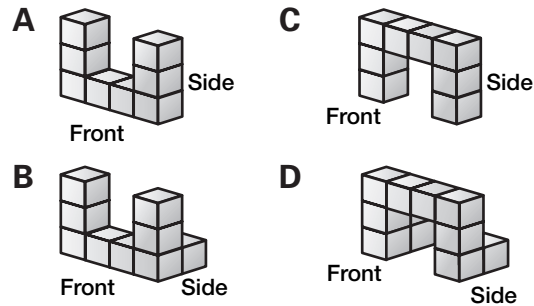

- 2 Which solid matches the top, front, and side views of the figure below?

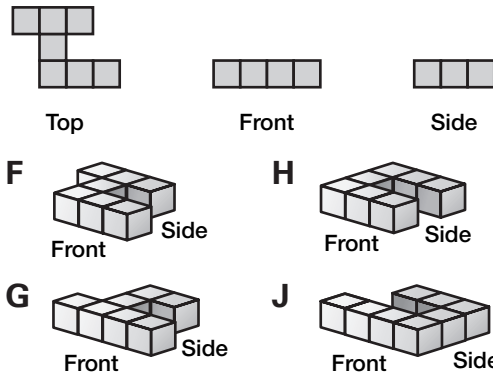

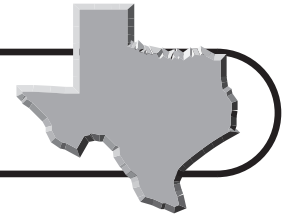

TAKS Practice (continued)

- 3 The top, side, and front views of a solid figure made of building blocks are shown below.

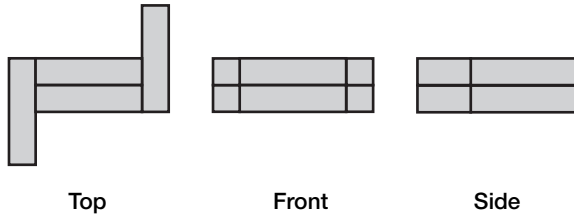

Which solid figure matches the views above?

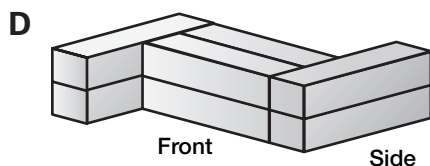
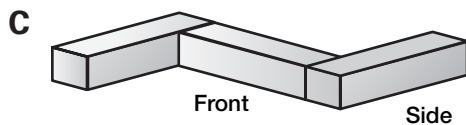
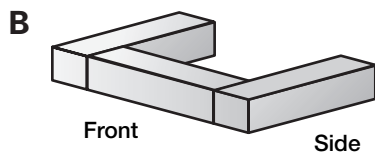
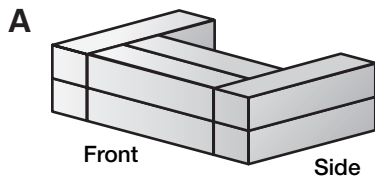

(7.8)(B) Geometry and spatial reasoning

The student uses geometry to model and describe the physical world. The student is expected to make a net (two-dimensional model) of the surface area of a three-dimensional figure.

- 1 What three-dimensional figure can be formed with net below?

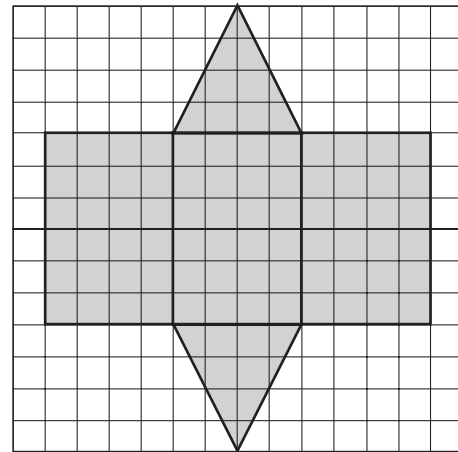

- A** Triangular prism
B Cube
C Regular pyramid
D Cone

- 2 What three-dimensional figure can be formed from the net below?

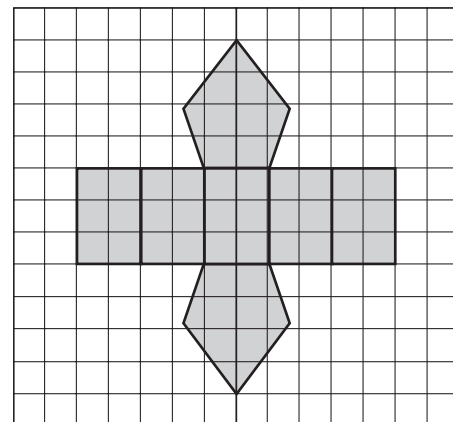

- F** Triangular pyramid
G Rectangular prism
H Pentagonal pyramid
J Pentagonal prism

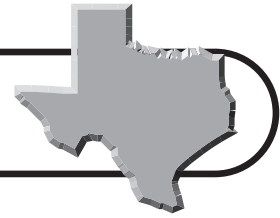

TAKS Practice (continued)

3 Which of the following nets can Jodi use to help her form a cone-shaped funnel?

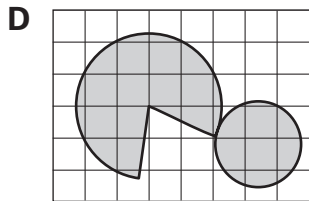
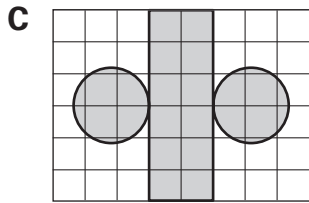
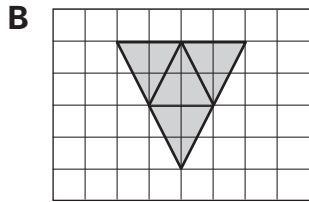
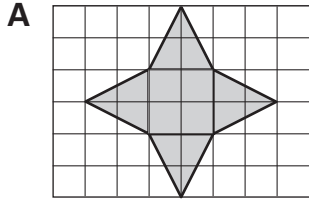

4 Which net represents the surface area of the rectangular prism shown?

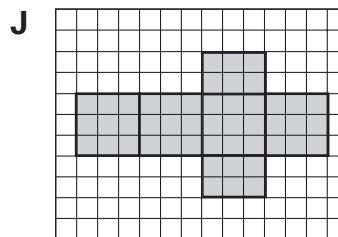
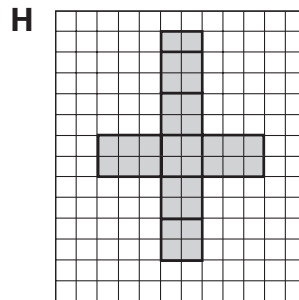
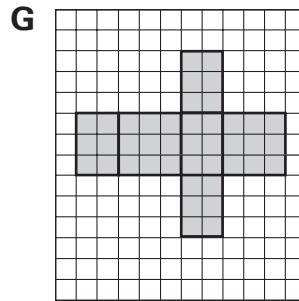
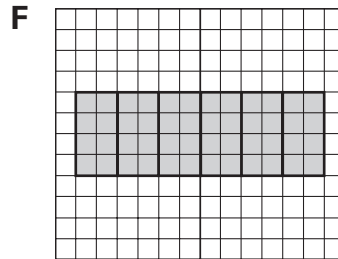
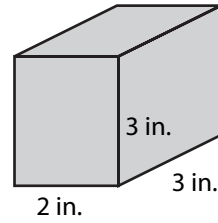

TAKS Practice (continued)

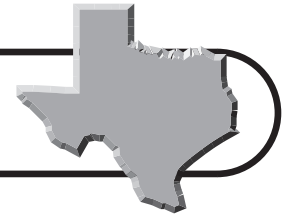

(7.8)(C) Geometry and spatial reasoning The student uses geometry to model and describe the physical world. The student is expected to use geometric concepts and properties to solve problems in fields such as art and architecture.

- 1** An architect drew blueprints for a new house. The diagram below shows the window that will be over the front door and its dimensions at a ratio of 1:6. What is the length of the window's actual base?

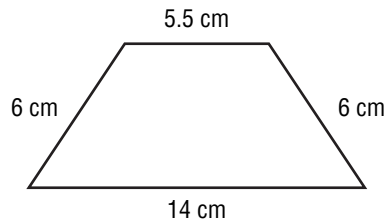

- A** 33 cm **C** 70 cm
B 36 cm **D** 84 cm

- 2** Dani drew the pattern below to use as a border for a quilt.

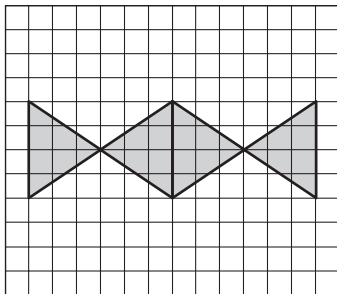

Which of the following best describes how Dani transformed the triangle to make the pattern?

- F** Reflection **H** Slide
G Translation **J** Rotation

- 3** A city planner used a coordinate grid to show the locations of parks in a city. Which ordered pair describes the location of Elver Park?

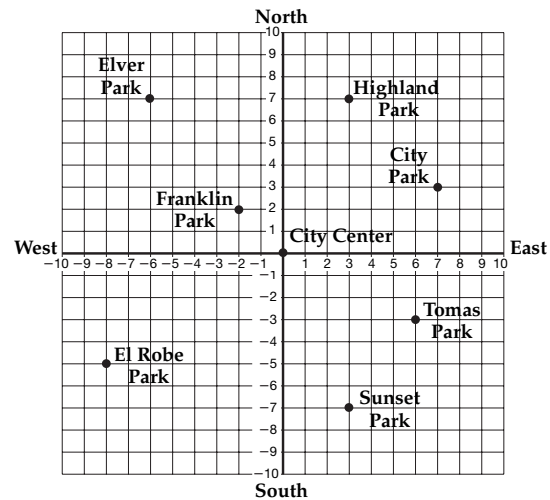

- A** (6, -3)
B (7, 3)
C (-8, -5)
D (-6, 7)

- 4** Jonas is an artist. He wants to make a design that uses only one shape repeatedly, with no overlapping shapes and no space in between shapes. Which geometric shape could he use?

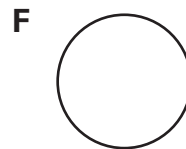

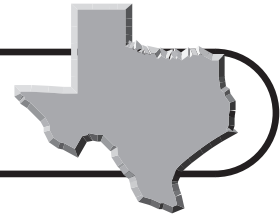

TAKS Practice

OBJECTIVE 4

Read each question and choose the correct answer.

(7.9)(A) Measurement The student solves application problems involving estimation and measurement. The student is expected to estimate measurements and solve application problems involving length (including perimeter and circumference) and area of polygons and other shapes.

- 1 Sari painted one wall of her bedroom, as shown below. She did not paint the window or the closet door.

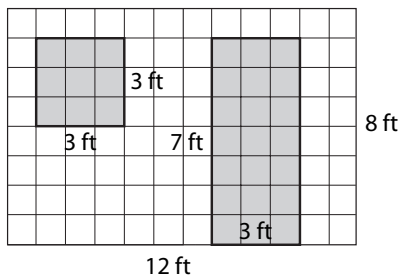

What is the area of the wall that Sari painted?

- A** 54 ft^2
B 66 ft^2
C 75 ft^2
D 96 ft^2
- 2 Carl bought a rain barrel to catch rainwater to water his garden. The rain barrel has a diameter of 3 feet. What is the approximate area of his garden that the barrel will occupy? Use 3.14 for π .
- F** 6.28 ft^2
G 7.07 ft^2
H 9.42 ft^2
J 50.27 ft^2

- 3 Joaquin bought a glass bowl that is 8 inches in diameter. He will send the bowl to his grandmother in a box. What must be the area of the bottom of the box so that the glass bowl will fit?

A 16 in^2 **C** $60\pi \text{ in}^2$
B 64 in^2 **D** 201 in^2

- 4 Jin is making a ceramic vase. The base of the vase has a radius of 4 centimeters. What is the approximate circumference of the base? Use 3.14 for π .

F 6 cm **H** 13 cm
G 8 cm **J** 25 cm

- 5 Coby competes in sandcastle building contests. He boxes an area of the beach that is 18 inches long and 48 inches wide. What is the area that Coby has boxed for his sand castle?

A 864 in^2 **C** 84 in^2
B 432 in^2 **D** 66 in^2

- 6 An indoor playground is 16.5 feet long and 9 feet wide. What is the area of the playground?

F 25.5 ft^2
G 51.05 ft^2
H 74.25 ft^2
J 148.5 ft^2

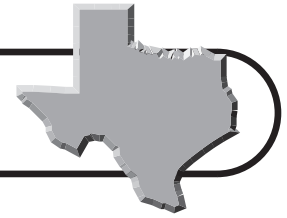

TAKS Practice (continued)

- 7** A round swimming pool has a cover with a diameter of 22 feet. Which of the following is the best estimate of the area of the swimming pool cover?
- A** 69 ft^2 **C** 484 ft^2
B 380 ft^2 **D** $1,520 \text{ ft}^2$

- 8** Mr. Yao is putting a fence around his vegetable garden, as shown below. How many feet of fencing will Mr. Yao need to buy?

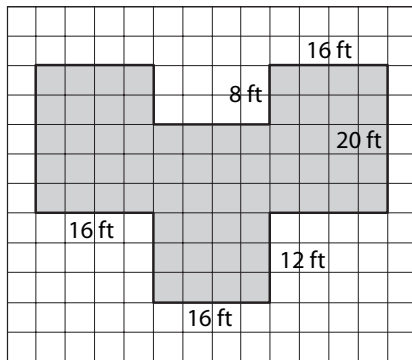

- F** 80 ft
G 124 ft
H 136 ft
J 176 ft
- 9** Jamie is putting 5-centimeter cubes in a box shaped like a rectangular prism. The dimensions of the box are 25 centimeters long, 15 centimeters wide, and 10 centimeters high. How many cubes will he need to cover one layer of the box?
- A** 15 **C** 25
B 20 **D** 30
- 10** A peach orchard is 80 meters long and has an area of 9,760 square meters. How wide is the orchard?
- F** 122 m **H** 145 m
G 130 m **J** 160 m

- 11** A school playground has an area that is covered with rubber chips. Each square of the grid represents 10 square feet. What is the approximate area of the playground that is covered with rubber chips?

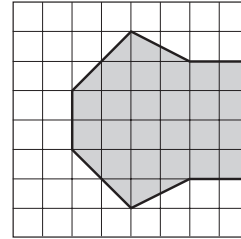

- A** 130 ft^2 **C** 260 ft^2
B 220 ft^2 **D** 300 ft^2
- 12** Ms. Hammerly is putting mulch on her flowerbed. The flowerbed is 10 feet long, 3 feet wide. Each bag of mulch will fill 2 square feet. How many bags of mulch will Ms. Hammerly need to cover the flowerbed?
- F** 7 **H** 15
G 13 **J** 60
- 13** Becca and her dad are making cement footings for a deck they are building. They use a cylindrical-shaped mold that is 22 inches high with a radius of 6 inches to make the footings. What is the approximate area of the top of the mold? Use 3.14 for π .
- A** 18.84 in^2 **C** 108 in^2
B 37.68 in^2 **D** 113.04 in^2
- 14** Mr. Dierks is building a sandbox for his children. He is using railroad ties for each side. How many feet of railroad ties will he need to build a square sandbox with sides that measure 6 feet in length?
- F** 24 ft **H** 48 ft
G 36 ft **J** 54 ft

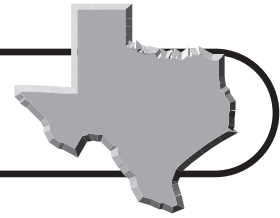

TAKS Practice (continued)

- 15** The indoor practice facility for the University of Texas football team is 125 yards long and 62 yards wide. What is the area of the practice field?
A 7,625 yd² **C** 22,875 yd²
B 7,750 yd² **D** 472,750 yd²
- 16** Mr. Tomlin is building a fishpond in his yard. The circular pond will have a diameter of 8 feet. How many square feet will the pond cover? Use 3.14 for π .
F 50.26 ft² **H** 101.06 ft²
G 78.53 ft² **J** 201.06 ft²
- 17** Keesha is decorating party hats for her younger sister's birthday party. She is gluing a piece of yarn around the base of each hat. The radius of the base is 8 centimeters. What is the approximate length of yarn that Keesha needs for each hat?
A 16 cm **C** 36 cm
B 25 cm **D** 50 cm
- 18** A model of the Texas State Capitol dome has a diameter of 40 inches. What is the approximate circumference of the model dome? Use 3.14 for π .
F 63 in. **H** 189 in.
G 126 in. **J** 251 in.
- 19** Tyler is building a small toy box for his younger sister. The dimensions of the box are 18 inches long, 12 inches wide, and 15 inches high. What is the area of the largest side of the box?
A 135 in²
B 270 in²
C 1620 in²
D 3240 in²
- 20** What is the area of a circle that has a radius of 18 centimeters? Use 3.14 for π .
F 113.04 cm²
G 703.36 cm²
H 1,017.36 cm²
J 1,720.04 cm²
- 21** A triangular window has a base of 30 inches and an area of 450 square inches. What is the height of the window?
A 15 in. **C** 45 in.
B 30 in. **D** 60 in.
- 22** What is the area of a rectangle that is 1 foot long and 6 inches wide?
F $\frac{1}{2}$ ft² **H** $2\frac{3}{4}$ ft²
G 2 ft² **J** 3 ft²
- 23** Chandra has a rectangular trampoline in her backyard. The trampoline is 12 feet long and has an area of 96 square feet. There is a net around the outside edge of the trampoline. What is the perimeter of the net in feet?
 Record your answer and fill in the bubbles on the grid below. Be sure to use the correct place value.
- | | | | | | | |
|---|---|---|---|---|---|---|
| 0 | 0 | 0 | 0 | . | 0 | 0 |
| 1 | 1 | 1 | 1 | | 1 | 1 |
| 2 | 2 | 2 | 2 | | 2 | 2 |
| 3 | 3 | 3 | 3 | | 3 | 3 |
| 4 | 4 | 4 | 4 | | 4 | 4 |
| 5 | 5 | 5 | 5 | | 5 | 5 |
| 6 | 6 | 6 | 6 | | 6 | 6 |
| 7 | 7 | 7 | 7 | | 7 | 7 |
| 8 | 8 | 8 | 8 | | 8 | 8 |
| 9 | 9 | 9 | 9 | | 9 | 9 |

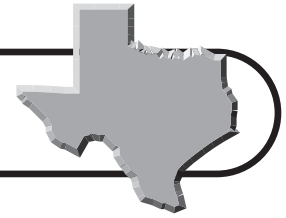

TAKS Practice

OBJECTIVE 5

Read each question and choose the correct answer.

(7.10)(A) Probability and statistics The student recognizes that a physical or mathematical model can be used to describe the experimental and theoretical probability of real-life events. The student is expected to construct sample spaces for simple or compound events.

- 1 Thea has 1 ten-dollar bill and 3 five-dollar bills in her wallet. Which list shows all of the possible outcomes if Thea randomly chooses 2 bills at the same time from her wallet without looking (and order does not matter)?

A

Dollar Bill Outcomes	
Ten	Five
Ten	Ten
Five	Five

B

Dollar Bill Outcomes	
Ten	Five
Five	Five

C

Dollar Bill Outcomes	
Ten	Five
Ten	One
Five	Five
Five	One

D

Dollar Bill Outcomes	
Five	Five
Ten	Five
Ten	One
Five	Five
Ten	Ten

- 2 A gumball machine has 2 red gumballs, 2 green gumballs, and 2 blue gumballs. Which list shows all of the possible combinations of gumballs that Damon can get if order does not matter?

F

Gumball Combinations		
Red	Red	Green
Red	Red	Blue
Red	Green	Green
Red	Blue	Blue
Red	Blue	Green
Green	Green	Blue
Green	Blue	Blue

G

Gumball Combinations		
Red	Red	Green
Red	Red	Blue
Red	Green	Green
Red	Blue	Blue

H

Gumball Combinations		
Red	Red	Green
Red	Blue	Green
Red	Green	Green
Green	Green	Blue

J

Gumball Combinations		
Red	Red	Green
Red	Red	Blue
Green	Green	Blue
Green	Blue	Blue

TAKS Practice (continued)

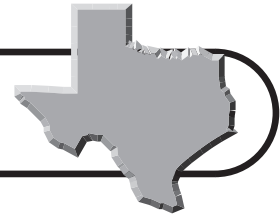

3 Michaela will toss a coin and roll a number cube and record the results. Which list shows all of the possible outcomes of her experiment?

- A** H1, H2, H3, H4, H5, H6
- B** H1, H2, H3, T4, T5, T6
- C** H1, H2, H3, H4, H5, H6, T1, T2, T3, T4, T5, T6
- D** H1, H2, H3, H4, H5, H6, T7, T8, T9, T10, T11, T12

4 In a board game, a player spins each of the two spinners shown below. Which of the following lists all of the possible combinations of an even number and either blue or red?

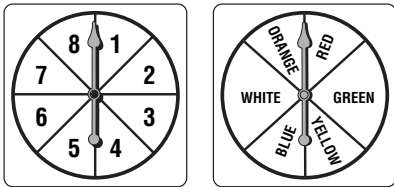

- F** 1-blue; 3-blue; 5-blue; 7-blue; 1-red; 3-red; 5-red; 7-red
- G** 1-blue; 2-blue; 3-blue; 4-blue; 5-blue; 6-red; 7-red; 8-red
- H** 2-red; 4-blue; 6-red; 8-blue; 2-red; 4-blue; 6-red; 8-blue
- J** 2-blue; 4-blue; 6-blue; 8-blue; 2-red; 4-red; 6-red; 8-red

5 Sheila's basketball team has 12 tickets to a San Antonio Spurs basketball game. Two tickets are for floor seats, 4 are box seats, 4 are for general admission seats, and 2 are for seats behind the basket. Sheila will draw one ticket without looking at its location. Which list shows all of the possible seating options Sheila can have?

- A** basket
box seats
bleachers
floor
general admission
- B** basket
box seats
floor
general admission
- C** floor
basket
general admission
bleachers
- D** box seats
basket
floor
bleachers

TAKS Practice (continued)

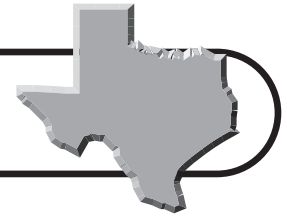

(7.11)(A) Probability and statistics The student understands that the way a set of data is displayed influences its interpretation. The student is expected to select and use an appropriate representation for presenting and displaying relationships among collected data, including line plot, line graph, bar graph, stem and leaf plot, circle graph, and Venn diagrams, and justify the selection.

1 Franklin Middle School collected information on the involvement of students in after-school activities. The school staff wants to compare how many students participate in each activity and the total number of students in the school. Which of these displays will best show this information?

- A** A bar graph
- B** A line graph
- C** A table
- D** A circle graph

2 Mr. Rockett wanted to find out how his students did on the most recent science test. He was interested in knowing how many students scored higher than 90%. Which of these displays will best show this information?

- F** Venn diagram
- G** Line plot
- H** Circle graph
- J** Line graph

3 The average daily low temperatures for January through June in Katy, Texas, are listed below.

January: 42°F

February: 46°F

March: 52°F

April: 58°F

May: 66°F

June: 72°F

Which of the following best displays how the average daily low temperature changes between January and June?

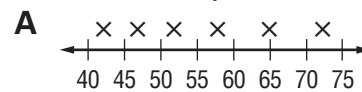

B **Daily Temperature**

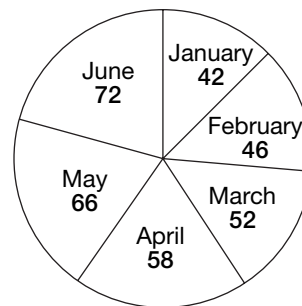

C

Stem	Leaf
4	2.6
5	2.8
6	6
7	2

D **Monthly Average Temperature**

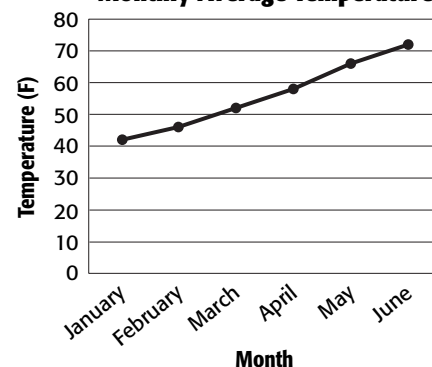

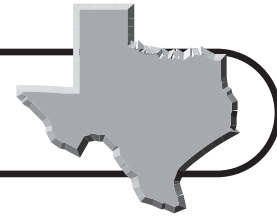

TAKS Practice (continued)

4 Anna surveyed 10 of her classmates to find out if they have sisters and brothers. Which of the following best displays which classmates have both brothers and sisters?

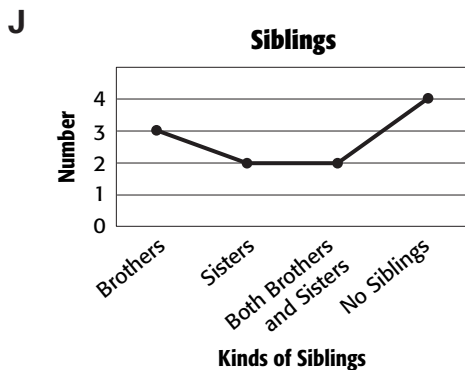
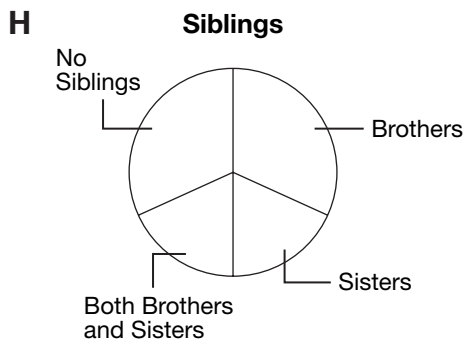
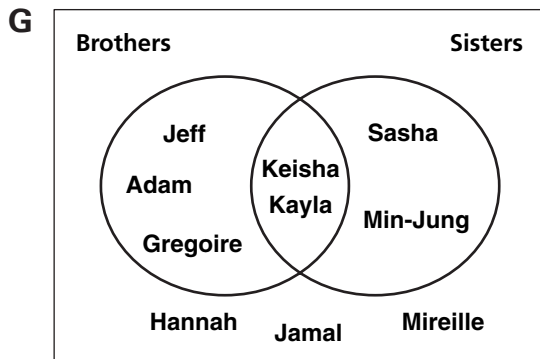
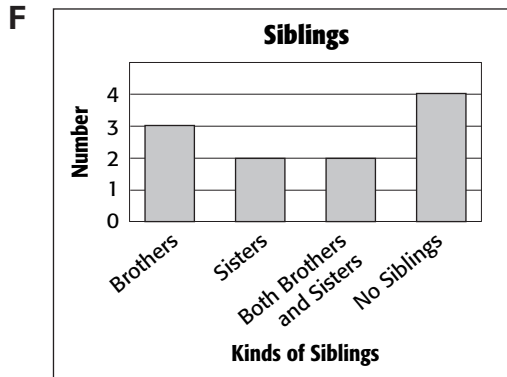

(7.11)(B) Probability and statistics The student understands that the way a set of data is displayed influences its interpretation. The student is expected to make inferences and convincing arguments based on an analysis of given or collected data.

1 The approximate population of Alamo, Texas, from 2000 to 2004 is shown below.

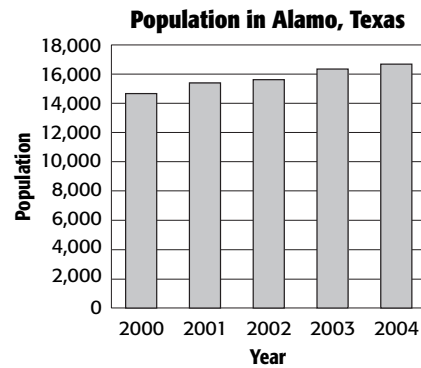

Which of these statements is supported by the data?

- A** The population of Alamo, Texas, is likely to decrease over the next 5 years.
- B** The population of Alamo, Texas, is likely to increase over the next 5 years.
- C** The population of Alamo, Texas, is likely to stay the same over the next 5 years.
- D** The population of Alamo, Texas, is likely to decrease over the next 2 years and then increase after that.

TAKS Practice (continued)

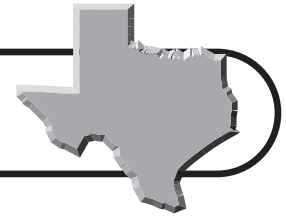

- 2 The table below shows the number of students at Midvale Middle School who are taking different foreign language classes.

Foreign Language	Number of Students
French	55
German	38
Spanish	62
Russian	17

Which of the following statements is supported by the data in the table?

- F** German is the least popular language choice.
- G** Russian is the most popular language choice.
- H** Spanish is the most popular language choice.
- J** French is the most popular language choice.
- 3 A clothing store tracked the sales of women's T-shirts for one month by color. The results are shown below.

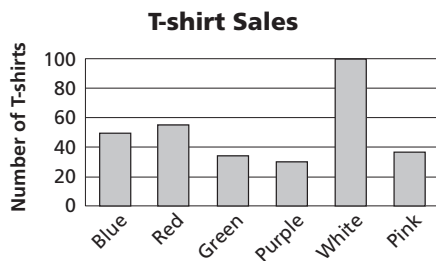

Which of the following statements is best supported by the data?

- A** The store sold out of its white T-shirts during the month.
- B** The number of purple T-shirts sold was half of the number of blue T-shirts sold.
- C** Most people prefer green T-shirts over blue T-shirts.
- D** Almost twice as many white T-shirts were sold as were red T-shirts.

The table shows the number of airline tickets sold at a travel agency each day during one week. Use this table to answer questions 4 and 5.

Day of Week	Number of Airline Tickets
Sunday	15
Monday	12
Tuesday	8
Wednesday	22
Thursday	30
Friday	14
Saturday	4

- 4 Which statement is supported by these data?
- F** Most people make their travel plans mid-week.
- G** Most people make their travel plans early in the week.
- H** Most people make their travel plans on the weekends.
- J** More people make their travel plans on Saturday than on Sunday.
- 5 Easy Travel is looking to increase their sales of airline tickets. Based on the data, what would be a good advertising promotion?
- A** Offer a discount for tickets bought on Wednesday.
- B** Offer a discount for tickets bought on Saturday.
- C** Open the agency for longer hours on Monday.
- D** Hire more staff for the weekends.

TAKS Practice (continued)

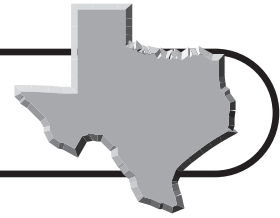

(7.12)(A) Probability and statistics The student uses measures of central tendency and range to describe a set of data. The student is expected to describe a set of data using mean, median, mode, and range.

- 1** Darla's family is landscaping their new yard. Darla's father bought 9 pecan trees for a total of \$225.00. Later that weekend, he bought another pecan tree for \$15.00. What was the mean cost of the pecan trees?
- A** \$15.00
B \$20.00
C \$24.00
D \$25.00

- 2** Michael has scores of 75, 84, and 86 on 3 math exams. What score must he get on the fourth exam to have a mean score of 85?

Record your answer and fill in the bubbles on the grid below. Be sure to use the correct place value.

				.		
0	0	0	0		0	0
1	1	1	1		1	1
2	2	2	2		2	2
3	3	3	3		3	3
4	4	4	4		4	4
5	5	5	5		5	5
6	6	6	6		6	6
7	7	7	7		7	7
8	8	8	8		8	8
9	9	9	9		9	9

- 3** The table below shows the hourly wage earned by 7 students at part-time jobs.

Student	Hourly Wage
Melissa	\$6.25
Tegan	\$6.00
Cade	\$6.25
Gabriel	\$6.50
Nell	\$7.25
Diego	\$6.75
Scott	\$6.00

What is the median hourly wage for these students?

- F** \$6.00 **H** \$6.75
G \$6.25 **J** \$7.25
- 4** Mrs. Fisk surveyed 6 of her students to find out about their homework times. The table below shows the results of her survey.

Student	Number of Weekly Hours Spent on Homework
Jessica	5
Allegra	4
Logan	7
Casey	8
Sean	6
Martina	

The number of hours that Martina spends doing homework is equal to the mean number of hours. How many hours does Martina usually spend on homework each week?

- A** 5 **C** 7
B 6 **D** 8

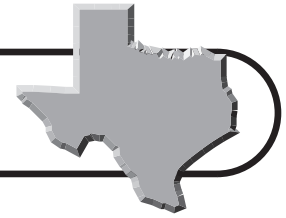

TAKS Practice (continued)

(7.12)(B) Probability and statistics The student uses measures of central tendency and range to describe a set of data. The student is expected to choose among mean, median, mode, or range to describe a set of data and justify the choice for a particular situation.

- 1** Ten of Mr. Ballard's math students received the following scores on an exam.

78, 85, 92, 91, 84, 91, 93, 88, 94, 87

Which measure of central tendency represents the most common exam score?

- A** Mean **C** Range
B Mode **D** Median

- 2** Five pairs of students each performed the same science experiment. They measured the number of seconds it took for crystals to begin to form on a piece of string in a solution. The results are shown in the table below.

Crystal Formation	
Student Pair	Number of Seconds
1	38
2	32
3	34
4	36
5	37
6	32

Which measure of central tendency does the time of 35 seconds represent?

- F** Mean
G Median
H Mode
J Range

- 3** Janet made the following number of points in five basketball games.

18, 4, 12, 9, 18

What measure of central tendency could Janet use to give the idea that she scores more points per basketball game than she actually does?

- A** Mean
B Median
C Mode
D Range

- 4** Connie rides her bicycle everyday. In the table below, she recorded the number of miles she rode every day for a week.

Day	Miles
Sunday	35
Monday	32
Tuesday	22
Wednesday	24
Thursday	41
Friday	22
Saturday	38

Which of the following does not describe the number of miles Connie rides on a typical day?

- F** Mean
G Median
H Mode
J Range

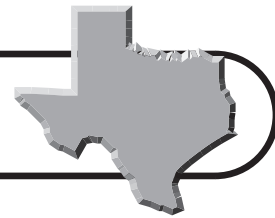

TAKS Practice

OBJECTIVE 6

Read each question and choose the correct answer.

(7.13)(A) Underlying processes and mathematical tools The student applies Grade 7 mathematics to solve problems connected to everyday experiences, investigations in other disciplines, and activities in and outside of school. The student is expected to identify and apply mathematics to everyday experiences, to activities in and outside of school, with other disciplines, and with other mathematical topics.

- 1** Four students took a science test. Dominik scored higher than Tara, Sasha, and Jake. Jake's score was lower than Sasha's and Tara's score. What information is needed to determine the order of the students' test scores from lowest to highest?
- A** Was Tara's score higher or lower than Jake's?
B Was Sasha's score higher or lower than Tara's?
C Was Dominik's score higher or lower than Tara's?
D Was Jake's score higher or lower than Sasha's?
- 2** Mr. Martinez is painting the entire inside of his house. He used $2\frac{1}{4}$ gallons of paint to cover 800 square feet in his living room. He used $\frac{1}{3}$ as much paint for his bedroom. Which equation can be used to find n , the number of gallons of paint he used in his bedroom?
- F** $n = 2\frac{1}{4} \cdot \frac{1}{3}$ **H** $n = 2\frac{1}{4} \div \frac{1}{3}$
G $n = 2\frac{1}{4} - \frac{1}{3}$ **J** $n = 2\frac{1}{4} + \frac{1}{3}$

- 3** Rita and her family are planning a trip to Corpus Christi. According to the map, it is 203 miles from their home in Tyler to Houston. From Houston, it is another 215 miles to Corpus Christi. What information is needed to estimate the number of hours it will take them to drive from Tyler to Corpus Christi?
- A** Total number of miles they will drive
B Number of miles per hour they expect to travel
C Number of gallons of gasoline the gas tank holds
D Average number of miles they can travel per gallon of gasoline
- 4** The table below shows the relationship between the volume of a cylinder and its radius if its height stays the same.

Height of Cylinder	Radius of Cylinder (cm)	Volume of Cylinder (cm ³)
5	1	15.7
5	2	62.8
5	3	141.3
5	4	251.2
5	5	392.5

Which statement is supported by information in the table?

- F** As the radius of the cylinder increases by 1, the volume stays the same.
G As the radius of the cylinder increases by 1, the volume doubles.
H As the radius of the cylinder increases by 1, the volume increases by 3 times more than the volume when the radius was 1.
J As the radius of the cylinder increases by 1, the volume of the cylinder increases as many times as the radius squared.

TAKS Practice (continued)

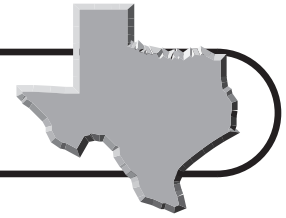

(7.13)(B) Underlying processes and mathematical tools The student applies Grade 7 mathematics to solve problems connected to everyday experiences, investigations in other disciplines, and activities in and outside of school. The student is expected to use a problem-solving model that incorporates understanding the problem, making a plan, carrying out the plan, and evaluating the solution for reasonableness.

- 1** Alexis solved the following problem.

The area of a circle is 200.96 centimeters. What is the radius of the circle?

Alexis found the radius of the circle must be 8 centimeters. Which of the following methods could NOT be used to check Alexis's solution?

- A** $3.14(8)^2 = 200.96$
- B** $\frac{200.96}{8 \times 8} = 3.14$
- C** $\frac{200.96}{8 + 8} = 3.14$
- D** $3.14 \times 8 \times 8 = 200.96$
- 2** Elisa is planning a banquet for 70 people. Each round table in the banquet hall seats 6 people. Elisa divides 70 by 6. What is the next step in finding the number of tables she needs for the banquet?
- F** Round the answer up.
- G** Round the answer down.
- H** Add 1 extra table.
- J** Subtract 1 table.

- 3** Maddie is camping with her family. They hiked each day of their five-day trip. Maddie used a pedometer to record the number of steps they hiked each day. She recorded the data in the table below.

Day	Number of Steps
1	15,278
2	12,865
3	14,654
4	10,265
5	9,202

It takes about 2,000 steps to walk a mile. What method can Maddie use to find the average number of miles they hiked each day?

- A** Add the number of steps each day, divide by 5, then divide by 2,000.
- B** Divide the number of steps each day by 2,000, then multiply by 5.
- C** Add the number of steps each day, divide by 2,000, then multiply by 5.
- D** Divide the number of steps each day by 5, then divide by 2,000.
- 4** Satchi is making a quilt. She needs to buy $1\frac{1}{4}$ yards of 4 different fabrics for the quilt top. She estimates she will need to buy 4 yards of fabric total to make the quilt. Is her solution reasonable?
- F** No, she did not add her estimates correctly.
- G** No, she needs to round up to make sure she has enough.
- H** Yes, she rounded correctly before she estimated.
- J** Yes, 4 yards is less than the total amount she needs.

TAKS Practice (continued)

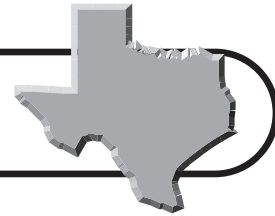

In Maya's history class, there is a 10-point quiz every week. Maya has recorded all of her scores so far in the table below. Use the data for Exercises 5 and 6.

Quiz	Score
1	9
2	9
3	7
4	8
5	8
6	7

- 5** What should Maya do to organize the data in order to identify on which quizzes she scored below her median score?
- A** She should add up all of her test scores.
B She should list her scores in order from greatest to least.
C She should list the scores in order from least to greatest with their corresponding quiz numbers.
D She should list the quiz numbers from greatest to least with their corresponding scores.
- 6** Maya decides that she would like to have an average of 9 on the 10 weekly quizzes for the term. She estimates that she will need to earn a 9 on the last 4 quizzes. Is her estimation reasonable?
- F** Yes. 9×4 is 36.
G Yes. She already has 2 scores of 9. Four more would make $6 \times 9 = 54$.
H No. She needs to earn a sum of 42 points.
J No. She will need to study longer.

(7.13)(C) Underlying processes and mathematical tools The student applies Grade 7 mathematics to solve problems connected to everyday experiences, investigations in other disciplines, and activities in and outside of school. The student is expected to select or develop an appropriate problem-solving strategy from a variety of different types, including drawing a picture, looking for a pattern, systematic guessing and checking, acting it out, making a table, working a simpler problem, or working backwards to solve a problem.

- 1** A baby tiger weighs 2.5 pounds at birth. Assuming she gains 3 pounds every 2 weeks, how much will the tiger weigh in 10 weeks?
- A** 10 lb
B 12.5 lb
C 15 lb
D 17.5 lb
- 2** Taryn earned money baby-sitting Saturday night. She spent $\frac{1}{2}$ of it on Sunday at the movies and $\frac{1}{4}$ of the remaining amount on lunch. After buying a book for \$7.55, she had \$6.25 left. How much did she earn baby-sitting on Saturday?
- F** \$13.80
G \$18.40
H \$36.80
J \$55.20

TAKS Practice (continued)

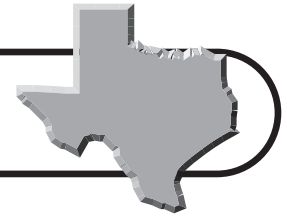

- 3** Which diagram below can best help you to solve the following problem?

Jada is sewing a flag in the shape of an equilateral triangle. Each side of the flag is 24 inches. The edging around the flag is 2 inches wide. What are the outside dimensions of the entire flag?

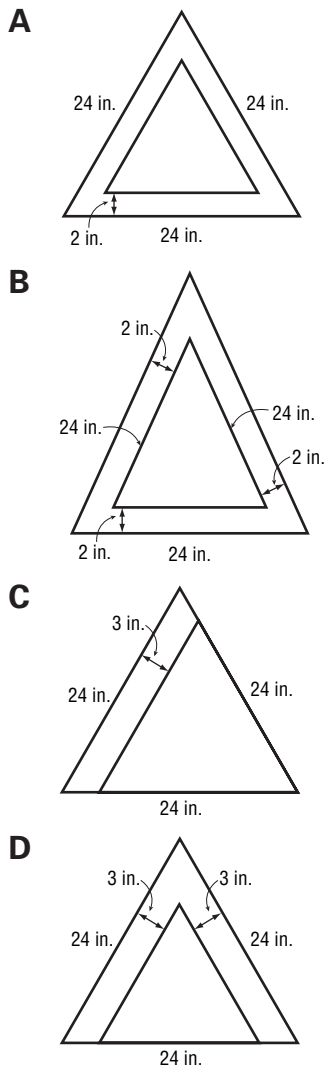

- 4** Quadrilateral $ABCD$ is similar to quadrilateral $JKLM$.

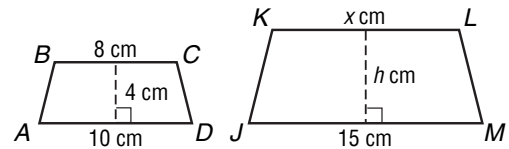

Which choice shows the equations that can be used to find the area of quadrilateral $JKLM$?

- F** First use $\frac{x}{8} = \frac{10}{15}$ and $\frac{4}{h} = \frac{10}{15}$.
Then use the formula, $A = 15h$.
- G** First use $\frac{8}{x} = \frac{10}{15}$ and $\frac{4}{h} = \frac{10}{15}$.
Then use the formula, $A = \frac{1}{2}(15 + x)h$.
- H** First use $\frac{8}{x} = \frac{10}{15}$ and $\frac{4}{h} = \frac{15}{10}$.
Then use the formula, $A = \frac{1}{2}(15 + x)h$.
- J** First use $\frac{8}{x} = \frac{10}{15}$ and $\frac{4}{h} = \frac{10}{15}$.
Then use the formula, $A = 15h$.

- 5** Kyra wants to buy a pair of running shoes that is sold at several different stores. The data set lists each store's price for the shoes.

\$46, \$48, \$58, \$44, \$48, \$48, \$52

Which of the following gives the most useful information about what price Kyra should expect to pay for the running shoes?

- A** Mean
B Median
C Mode
D Range

TAKS Practice (continued)

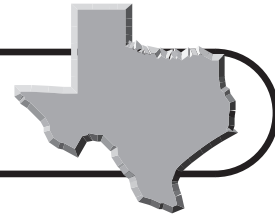

(7.14)(A) Underlying processes and mathematical tools The student communicates about Grade 7 mathematics through informal and mathematical language, representations, and models. The student is expected to communicate mathematical ideas using language, efficient tools, appropriate units, and graphical, numerical, physical, or algebraic mathematical models.

- 1 Identify the equation below that models $a(b + c) = ab + ac$.

A $2(3 + 4) = 2 \times 3 + 2 \times 4$

B $2^{3+4} = 2 \times 3 + 2 \times 4$

C $\frac{2}{3 \times 4} = \frac{2}{3} + \frac{3}{4}$

D $2(3 + 4) = 2^3 + 2^4$

- 2 Alberto is making a round table. He would like the area of the table to be about 12 square feet. Which equation can he use to find r , the radius of a table of this size?

F $r = \frac{12}{\pi}$ **H** $r = \sqrt{\frac{12}{2\pi}}$

G $r = \frac{12}{2\pi}$ **J** $r = \sqrt{\frac{12}{\pi}}$

- 3 George spends 30 hours each week training for triathlons. He is either at work or training 55 hours a week. If he works the same number of hours each day, Monday through Friday, which equation can be used to find h , the number of hours he spends at work each day?

A $h = \frac{55 + 30}{5}$ **C** $h = \frac{55 - 30}{7}$

B $h = \frac{55 - 30}{5}$ **D** $h = \frac{55 + 30}{7}$

- 4 Mr. Jamison bought 7 tickets on the lawn for a Texas Rangers baseball game for \$385. Which equation can be used to find the cost of 2 tickets on the lawn to the baseball game?

F $\frac{7}{2} = \frac{x}{385}$

G $\frac{7}{x} = \frac{2}{385}$

H $\frac{385}{7} = \frac{2}{x}$

J $\frac{7}{385} = \frac{2}{x}$

- 5 The owner of a camping store buys water bottles wholesale and sells them for \$6.99 each. The table shows the number of water bottles she sold each week in June.

Week	Number of Water Bottles
1	21
2	36
3	42
4	29

What piece of information is needed to find the amount of profit she made from the sale of water bottles in June?

- A** The total number of water bottles she sold
B The number of water bottles she bought
C How much she paid for each water bottle
D The number of water bottles she sold each day

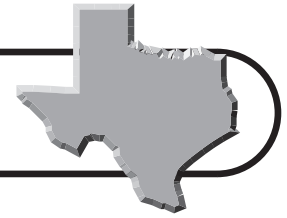

TAKS Practice (continued)

- 6** Jennifer is making a quilt for her bed. She would like the quilt to be 48 inches wide and 84 inches long. She has some scrap material she may be able to use for the edging. What equation can she use to find p , the perimeter of the quilt, to know if she has enough material for the edging?

F $P = 48 \times 84$

G $P = 2(48) \times 2(84)$

H $P = 2(48) + 2(84)$

J $P = 48 + 84$

- 7** A recipe for 8 muffins calls for $1\frac{1}{2}$ cups of flour. Which equation can be used to find how much flour is needed to make two-dozen muffins?

A $\frac{8}{1\frac{1}{2}} = \frac{24}{x}$ **C** $\frac{1\frac{1}{2}}{x} = \frac{24}{8}$

B $\frac{1\frac{1}{2}}{8} = \frac{24}{x}$ **D** $\frac{8}{x} = \frac{24}{1\frac{1}{2}}$

- 8** A home appliance repair company charges \$50 to come to your home. The cost to repair an appliance is \$45 per hour. Which equation best models how much the company would charge to repair your dishwasher?

F $C = h(50 + 45)$

G $C = 50 + 45h$

H $C = 45 + 50h$

J $C = (50 - 45)h$

(7.15)(A) Underlying processes and mathematical tools

The student uses logical reasoning to make conjectures and verify conclusions. The student is expected to make conjectures from patterns or sets of examples and nonexamples.

- 1** Katrina and her neighbor have started walking together to keep fit. The first week they walked $1\frac{1}{2}$ miles each day. The second week they walked 2 miles each day. If this pattern continues, how far will they walk each day the fifth week?

A $2\frac{1}{2}$ mi

B 3 mi

C $3\frac{1}{2}$ mi

D 4 mi

- 2** The table below shows the number of movies in each category that were rented from a local video store in one week.

Film Category	Number of Films Rented
Action	266
Comedy	451
Drama	202
Family	56

Based on the information in the table, which of the following is a reasonable assumption?

- F** About 4 times more drama films were rented than family films.
- G** Comedy films were more than twice as popular as action films.
- H** Drama films were the most popular type of film rented.
- J** Only half as many drama films as action films were rented.

TAKS Practice (continued)

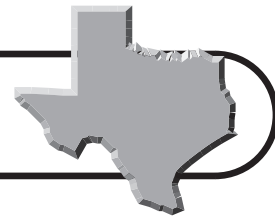

- 3** The numbers in the table below were sorted according to a certain rule. The numbers that follow the rule are in the “Blue” group and the numbers that do not follow the rule are in the “Red” group. Which of the following best describes the rule for the numbers in the Blue row?

Blue	3.54	2.73	18.3	23.5	34.8	5.38	13.85
Red							

- A** Include the digit 3
B Have exactly 3 digits
C Are written to the hundredths place
D Have odd numbers in the tenths place
- 4** Six geometric figures were sorted according to a rule.

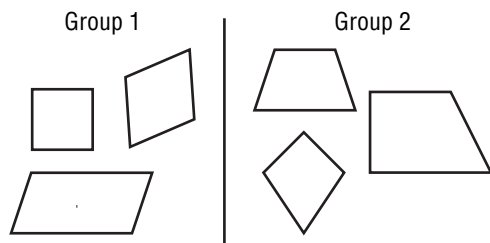

Which figure belongs in Group 1?

- F**
- G**
- H**
- J**

(7.15)(B) Underlying processes and mathematical tools The student uses logical reasoning to make conjectures and verify conclusions. The student is expected to validate his/her conclusions using mathematical properties and relationships.

- 1** At Casey’s Supermarket, you can buy apples in 4 different size bags. The bags and their prices are listed in the table.

Size of Bag of Apples	Price
$\frac{1}{2}$ lb	\$1.99
1 lb	\$2.99
$1\frac{1}{2}$ lb	\$4.29
2 lb	\$5.29

Which bag of apples should you choose if you want to pay the least amount of money per pound of apples?

- A** $1\frac{1}{2}$ lb **C** $1\frac{1}{2}$ lb
B 1 lb **D** 2 lb
- 2** $\angle RST$ and $\angle XYZ$ are complementary angles. If the measure of $\angle RST$ is 32° , what is the measure of $\angle XYZ$?
- F** 32° , because the measures of complementary angles are equal
G 58° , because the sum of the measures of complementary angles is 90°
H 148° , because the sum of the measures of complementary angles is 180°
J 328° , because the sum of the measures of complementary angles is 360°

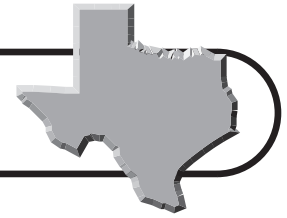

TAKS Practice (continued)

The table below shows the prices of chicken noodle soups made by four different companies. Use this table to answer questions 3 and 4.

Soup Manufacturer	Size of Can	Price
Sonny's Soups	20 oz	\$2.20
Soup Tonight	16 oz	\$1.80
A Cup a Day	8 oz	\$0.95
Grandma Jane's	12 oz	\$1.30

- 3** Which can of soup should Jeret buy if he is trying to save money?
- A** Soup Tonight, because it costs less than \$2.00
- B** Sonny's Soups, because it is the biggest can of soup
- C** A Cup a Day, because it costs the least amount of money
- D** Grandma Jane's, because it is the most soup for the money
- 4** Sonny's Soups will package a 10-ounce can of soup. What price should the manufacturers sell the 10-ounce can if they want it to cost less per ounce than Grandma Jane's 12-ounce can?
- F** \$1.05
- G** \$1.15
- H** \$1.25
- J** \$1.30

- 4** Which of the following is a valid conclusion from the data in this graph?

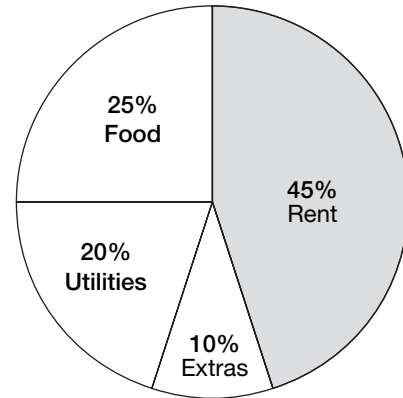

- A** More than half of the total amount is devoted to rent.
- B** The greatest single expense is less than half the total.
- C** Rent represents a smaller percent than food and utilities combined.
- D** The greatest single expense is food.
- 5** Jackie drew the following figures.

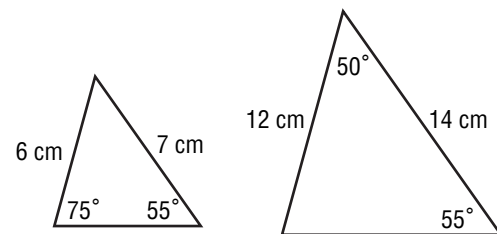

Which of the following best describes the relationship between the two figures?

- F** regular, because their side lengths are the same
- G** congruent, because they have the same angle measures
- H** similar, because they have the same angle measures and their corresponding sides are proportional
- J** symmetric, because they have the same angle measures and their corresponding sides are the same length

Practice Test

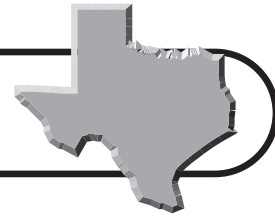

Read each question and choose the correct answer.

- 1 The table below shows the favorite kinds of pizza toppings for students at Jefferson Middle School.

Topping	Number of Students
Pepperoni	300
Sausage	210
Cheese	180
Veggie	155

Based on the information in the table, which of the following is a reasonable assumption?

- A** Cheese pizza is the most popular kind of pizza.
- B** Veggie pizza is twice as popular as pepperoni.
- C** Sausage pizza is almost twice as popular as cheese pizza.
- D** Nearly two times as many students like pepperoni pizza as cheese pizza.
- 2 Some sixth-, seventh-, and eighth-grade students spend time at the elementary school tutoring students. Of the students who tutor, 12 are sixth-graders, 18 are seventh-graders, and 6 are eighth-graders. What percent of the tutors are seventh-graders?
- F** 18%
- G** 36%
- H** 50%
- J** 75%

- 3 The model below represents the equation $3x + 3 = 6y + 3$.

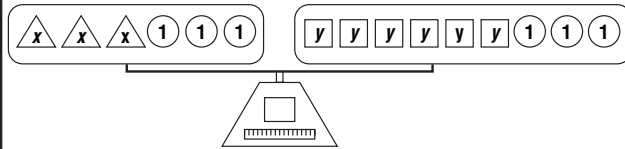

What is the value of x ?

- A** $x = 2y$
- B** $x = 6y$
- C** $x = 6y + 3$
- D** $x = 3y + 3$
- 4 Simplify the expression below.
- $$(8 - 5)^2 \div 3 + 16 \times 2$$
- F** 33 **H** 37
- G** 35 **J** 39
- 5 The seventh-grade class is going on a field trip to the state capital in Austin. The adult to student ratio for the field trip is 1:14. If there are 252 seventh-grade students, how many adults will go on the field trip?
- A** 14 **C** 22
- B** 18 **D** 26
- 6 A map of downtown San Antonio has a scale of 1 inch equals 1,000 feet. If the walking distance between the Children's Museum and the Alamo on the map is 1.4 inches, what is the actual walking distance?
- F** 1.4 ft **H** 140 ft
- G** 14 ft **J** 1,400 ft



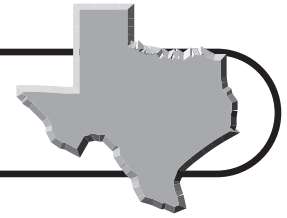

Practice Test (continued)

7 Sadie drew the following 4 figures.

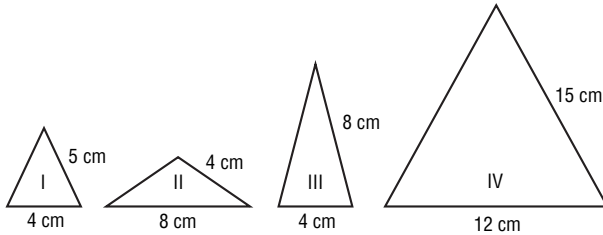

Which two figures are similar?

- A Figure I and Figure II
- B Figure I and Figure IV
- C Figure II and Figure III
- D Figure II and Figure IV

8 The table below shows what 5 students charge per hour for baby-sitting.

Baby-sitter	Fee per Hour
Tanner	\$6.50
Yuriko	\$7.00
Natalia	\$5.50
Aldon	\$7.00
Kaitlyn	\$8.00

What is the mean fee per hour for baby-sitting?

- F \$2.50
- G \$5.50
- H \$6.80
- J \$7.00

9 Alejandro is making a cylinder to hold his posters. He wants the circumference of the base to be 11 centimeters. What equation can he use to find r , the radius of the base of the cylinder?

- A $r = \frac{11}{2\pi}$
- B $r = \frac{11}{\pi}$
- C $r = \frac{2}{11\pi}$
- D $r = \frac{2}{\pi}$

10 If quadrilateral $ABCD$ is translated 5 units to the right and 6 units up, what will be the new coordinate of point B ?

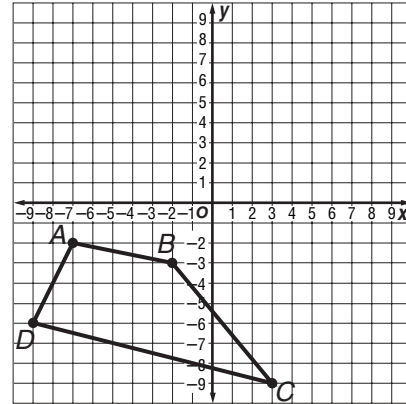

- F (3, 3)
- G (3, -9)
- H (-7, 3)
- J (-7, -9)

11 Robert runs between 4 and 8 miles every day. Which is the best estimate of the total number of miles he runs in a week?

- A 20
- B 40
- C 60
- D 80

12 Mr. Jeffries is making a wooden clock. The round face of the clock has a diameter of 9 inches. What is the area of the face of the clock to the nearest tenth of a square inch?

- F 254.3 in.^2
- G 63.6 in.^2
- H 28.3 in.^2
- J 14.13 in.^2



Practice Test (continued)

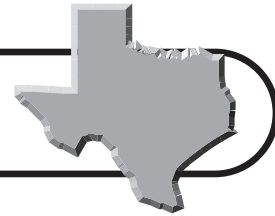

- 13** The top, front, and side views of a solid figure are shown below.

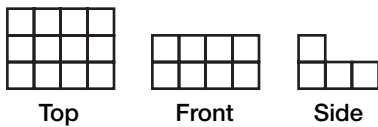

Which solid figure matches the views above?

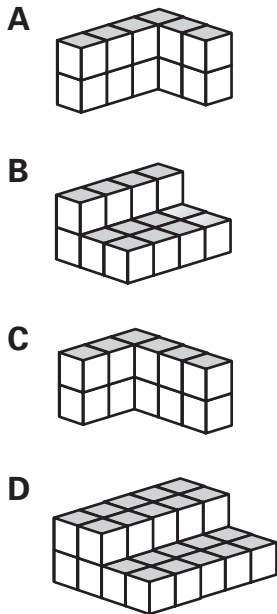

- 14** Jill and Bryan are estimating the monthly cost of utilities for an apartment they plan to rent. They must pay for electricity and telephone service. The telephone service will cost \$36.99 a month, and they expect to use an average of 80 kilowatts of electricity each month. What additional information do they need to estimate their monthly utility bill?
- F** The cost per kilowatt hour for electricity.
- G** The cost of telephone service per phone call.
- H** The cost of long distance and their net income.
- J** The cost of light bulbs and the number of daylight hours.

- 15** If $\angle K$ and $\angle J$ are complementary angles and the measure of $\angle K$ is 53° , what is the measure of $\angle J$?
- A** 123° **C** 53°
B 80° **D** 37°

- 16** Maggie had $\frac{2}{5}$ of her birthday cake left after her party. She put $\frac{3}{4}$ of what was left in the freezer. Which diagram is shaded to show the part of the cake she put in the freezer?

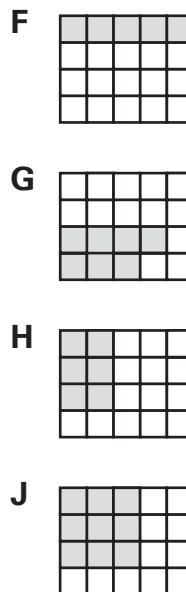

- 17** Which sequence follows the rule $2n - 3$, where n represents the position of a term in the sequence?
- A** $-1, 1, 3, 5, 7, \dots$
B $-1, 3, 7, 11, 15, \dots$
C $1, 3, 5, 7, 9, \dots$
D $3, 6, 9, 12, 15, \dots$



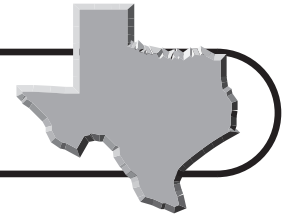

Practice Test (continued)

- 18** Which expression is represented by the model below?

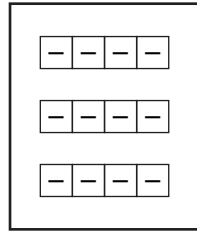

- F** $-12 + 3$
G $-12 \div 3$
H -3×4
J $-4 + 3$
- 19** The population of Houston increased by 15.1% between 1990 and 2000. Which number is equivalent to 15.1%?
- A** $\frac{15.1}{1,000}$
B $\frac{15.1}{100}$
C 0.0151
D 1.51
- 20** Which of the following relationships is best represented by the data in the graph?

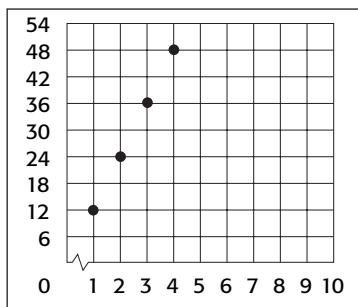

- F** Conversion of hours to minutes
G Conversion of yards to feet
H Conversion of months to days
J Conversion of years to months

- 21** Which problem situation matches the equation below?

$$x + 10.55 = 11.18$$

- A** Kylie bought a shirt that had a price of \$10.55. The total cost was \$11.18. What is x , the amount of sales tax?
B Suzette paid \$11.18 for a book. She gave the cashier \$10.55. What is x , the amount of change she received?
C Calvin ran the 100-yard dash in 11.18 seconds. His friend ran it in 10.55 seconds. What is x , the number of seconds Calvin was faster than his friend?
D Devin measured the distance on a map from Houston to Dallas as 11.18 inches. The distance from Houston to Austin was 10.55 inches. What is x , the number of miles from Austin to Dallas?
- 22** Which of the following has lateral faces that are parallelograms?
- F** Cone **H** Pyramid
G Prism **J** Cylinder
- 23** A painting company is painting 4 different houses. They have completed $\frac{5}{8}$, $\frac{1}{4}$, $\frac{3}{4}$, and $\frac{3}{8}$ of the work on the houses. Which list shows the percentage of work completed on the houses in order from least to greatest?
- A** 25%, 40%, 60%, 75%
B 75%, 62.5%, 37.5%, 25%
C 0.25%, 0.375%, 0.625%, 0.75%
D 25%, 37.5%, 62.5%, 75%



Practice Test (continued)

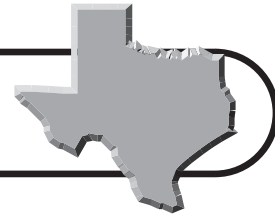

24 Choose the best description for the figure.

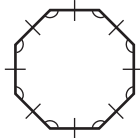

- F** Regular hexagon
- G** Hexagon
- H** Regular octagon
- J** Octagon

25 Which of the following coordinates is within the circle graphed below?

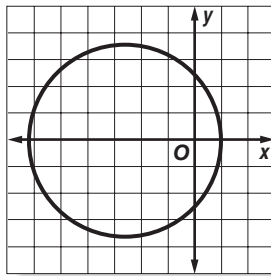

- A** $(-3, 4)$
- B** $(0, 3)$
- C** $(-4, -3)$
- D** $(-3, 4)$

26 Deidre purchases a book for \$6.58 and a calendar for \$10.99. If she gives the cashier \$20.00, how much change should she receive?

- F** \$2.43
- G** \$4.41
- H** \$9.01
- J** \$13.42

27 In a science experiment, Jada collected the following data.

Distance Toy Car Rolled from Ramp

Trial	Distance (cm)
1	33
2	29
3	27
4	35
5	25
6	22

Which measure of data is represented by 28?

- A** Mean
- B** Median
- C** Mode
- D** Range

28 Marissa flies roundtrip from Dallas to Houston for meetings. The flight distance from Dallas to Houston is 247 miles. In January, she flew to Houston 3 times. What is a good estimate of the number of miles she flew in January?

- F** 2,000 miles
- G** 1,500 miles
- H** 1,000 miles
- J** 750 miles

29 The form of a cement wall for an outdoor fountain is 18 feet long, 2 feet high, and 6 inches wide. How many cubic feet of cement will fill the form?

- A** 18 ft^3
- B** 36 ft^3
- C** 48 ft^3
- D** 54 ft^3



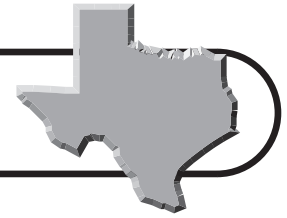

Practice Test (continued)

- 30** Which three-dimensional figure can be formed from the net below?

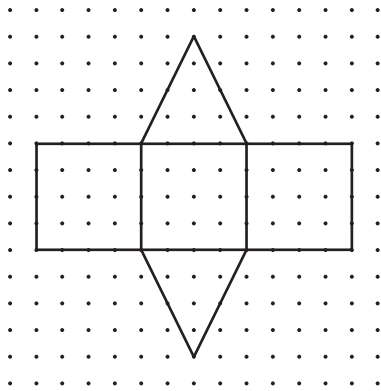

- F** Cube
G Triangular prism
H Rectangular prism
J Triangular pyramid
- 31** Nine students received the following scores on a 10-point quiz. What does the score of a 10th student need to be for the data set to have a range of 7?

8, 4, 5, 8, 6, 7, 9, 10, 9

- A** 3
B 7
C 9
D 10
- 32** Trevor goes for a run every 3 days and a bike ride every 4 days. If he bikes and runs on Tuesday, in how many days will he bike and run on the same day again?
- F** 3 days
G 4 days
H 8 days
J 12 days

- 33** Lilly has a bag of silk scarves with 1 blue scarf, 3 yellow scarves, and 1 red scarf. She pulls one scarf out of the bag and does not replace it. Then she pulls a second scarf out of the bag. Which list shows all of the possible outcomes if order is important?

A

Blue	Yellow
Blue	Red
Yellow	Blue
Yellow	Yellow
Yellow	Red
Red	Blue

B

Blue	Blue
Blue	Yellow
Blue	Red
Yellow	Blue
Yellow	Yellow
Yellow	Red
Red	Blue

C

Blue	Yellow
Blue	Red
Yellow	Blue
Yellow	Yellow
Yellow	Red
Red	Blue
Red	Yellow

D

Blue	Red
Yellow	Blue
Yellow	Yellow
Yellow	Red
Red	Blue
Red	Yellow

Go on

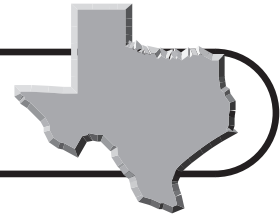

Practice Test (continued)

34 The table shows the population of Texas every 10 years from 1940 to 1990.

Texas Population	
1940	6,414,824
1950	7,677,832
1960	9,579,677
1970	11,196,730
1980	14,229,191
1990	16,986,510

Based on the data in the table, which of the following is not a reasonable statement?

- F** Between 1950 and 1970, the population of Texas increased by about 1.5 times.
- G** The population of Texas in 2010 will be greater than 15,000,000.
- H** Between 1940 and 1970, the population of Texas nearly doubled.
- J** The population of Texas in 1975 was more than 14,000,000.

35 Which of the following does the drawing represent?

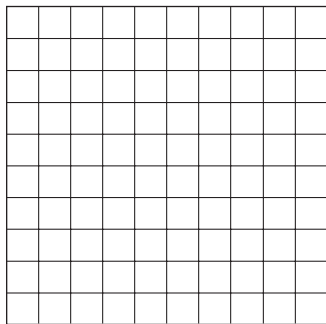

- A** $10^2 = 12$
- B** $10^2 = 8$
- C** $10^2 = 20$
- D** $10^2 = 100$

36 Mrs. Holland determined her students' grades for the first semester. Which of the following representations makes it easiest to see what part of the class got each grade?

F First Semester Grades

Grade	Number of Students
A	10
B	8
C	5
D	1
E	1

G First Semester Grades

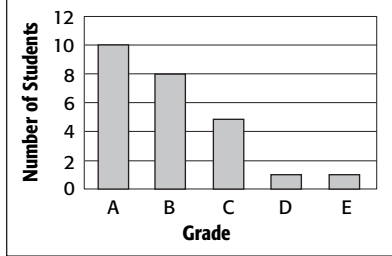

H First Semester Grades

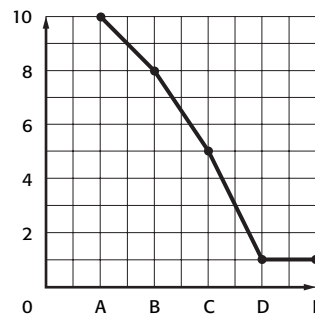

J First Semester Grades

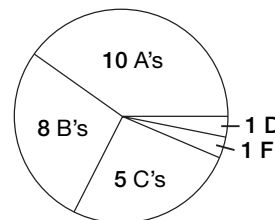

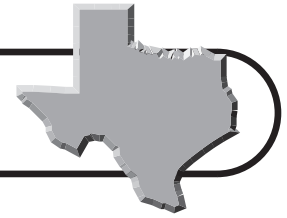

Practice Test (continued)

37 Jamal is having a barbecue. He invites 25 people. He buys hot dogs in packages of 12 and hot dog buns in packages of 8. If he buys enough hot dogs and hot dog buns for each person to have 2 hot dogs, how many more hot dogs will he have than hot dog buns?

- A** 4
- B** 8
- C** 12
- D** 16

38 The sixth-grade class has 325 students. Twenty-four percent of the students in sixth grade participate in an after-school program. Estimate the number of students that participate in the after-school program.

- F** 60
- G** 75
- H** 90
- J** 105

39 Beth is making a cylindrical cup from clay in art class. The base of her cup is shown below. Use the ruler on the Mathematics Chart to measure the radius of the base of the cup in inches.

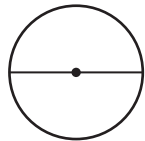

Which of the following is the closest to the area of the base of the cup? Use 3.14 for π .

- A** 7 in²
- B** 9 in²
- C** 14 in²
- D** 28 in²

40 Luke is designing a game with a number cube numbered 1–6 and a spinner with 3 equal parts, numbered 1–3. How many different combinations of 1 roll of the number cube and 1 spin of the spinner must Luke consider for his game?

- F** 6
- G** 9
- H** 12
- J** 18

41 A bicycle shop sells a certain bicycle for \$450. Three other bicycle shops sell the same bicycle for \$400, \$400, and \$600, respectively. What measure of central tendency should the first bicycle shop use to describe these data to its customers?

- A** Mean
- B** Median
- C** Mode
- D** Range

42 The following sequence forms a pattern.

0.5, 1, 1.5, 2, 2.5, 3

If this pattern continues, which expression can be used to find the 6th term?

- F** $6 \div 0.5$
- G** 6×0.5
- H** $6 + 0.5$
- J** $6 - 0.5$



Practice Test (continued)

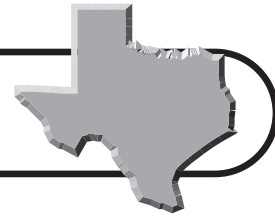

- 43** Mr. Mendez gave his science class two sets of measurements that were sorted according to a certain rule. The measurements that follow the certain rule were listed as “Correct” and the numbers that did not follow the rule were listed as “Incorrect.”

Correct	29.65	30.82	45.39	52.61	84.62
Incorrect	35.1	88.2	95.4	17.4	18.6

Based on this information, what can be said of the correct measurements?

- A** They all have exactly 4 non-zero digits.
 - B** They all include the digit 2.
 - C** They all measure to the nearest tenth.
 - D** They all measure to the nearest hundredth.
- 44** Jessica is going to a movie with 7 friends. Four theaters have Saturday matinees as shown in the table.

Theater	Saturday Afternoon Matinee
Hillcrest	3 tickets for \$12.50
East Point	4 tickets for \$14.00
Galaxy	2 tickets for \$8.50
Windgate	1 ticket for \$3.75

If Jessica and her friends want to pay as little as possible for movie tickets, to which theater should they go?

- F** East Point; they can buy 8 tickets at a cost of \$3.50 per ticket.
- G** Windgate; they can each buy their own tickets.
- H** Hillcrest; the choice of movies is better.
- J** Galaxy; the price of each ticket is \$4.25.

- 45** Maria bought 2 bottles of orange juice for \$1.25 each, a bag of bagels for \$4.55, and a container of cream cheese for \$2.19. She paid 8.5% sales tax. What other information is necessary to find Maria’s correct change?

- A** The amount of money she gave to the cashier
- B** The amount of money she paid in sales tax
- C** The total cost of her purchase
- D** The number of bagels she bought

- 46** Louis hired bricklayers to make a sidewalk that is 12 feet long and 3 feet wide. Each bricklayer covers 20 square inches. What is the first step in finding how many bricklayers he hired to make the sidewalk?

- F** Find the area of the sidewalk.
- G** Divide the area of the sidewalk by 20.
- H** Convert square feet to square inches.
- J** Convert 20 square inches to square feet.

- 47** Evan cut a cardboard box that is 10 cm by 6 cm by 15cm to make a bed for his hamster. He filled it with shredded paper. What is the volume of shredded paper Evan used to fill the bed?

- A** 75 cm³
- B** 150 cm³
- C** 450 cm³
- D** 900 cm³

- 48** In Flower Mound, 97.4% of the residents in 2000 had graduated from high school. Which number is not equivalent to 97.4%?

- F** $\frac{97.4}{100}$
- G** $\frac{974}{1000}$
- H** 0.974
- J** 97.4



Countdown to TAKS

25 Weeks to TAKS

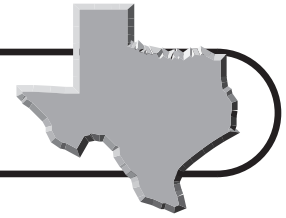

Monday

- 1 The first four figures of a pattern are shown. How many cubes will be used to construct the next figure in the pattern? **(7.2)(F)**

- A** 50
B 64
C 100
D 125

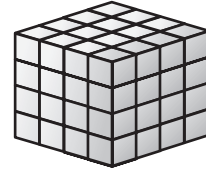
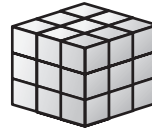

Tuesday

- 2 Texas farmers produce about $\$10^9$ worth of cotton each year. Which of the following amounts is equal to this expression? **(7.2)(E)**

- F** \$100,000,000
G \$1,000,000,000
H \$10,000,000,000
J \$100,000,000,000

Wednesday

- 3 What is the value of the following expression? **(7.2)(E)**

$$12 + 4(5 - 3) - 6 \times 1$$

0	0	0	0	.	0	0
1	1	1	1		1	1
2	2	2	2		2	2
3	3	3	3		3	3
4	4	4	4		4	4
5	5	5	5		5	5
6	6	6	6		6	6
7	7	7	7		7	7
8	8	8	8		8	8
9	9	9	9		9	9

Thursday

- 4 What is the common difference of the sequence? **(7.4)(C)**

2.5, 3.7, 4.9, 6.1, 7.3, 8.5, ...

- A** 1.2
B 1.5
C 2.5
D 2.6

Friday

- 5 The table shows how much money Jamie has saved this year. The amounts represent a geometric sequence. What is the common ratio of the sequence? **(7.4)(C)**

- F** 1.1
G 1.25
H 1.5
J 2

Month	Amount Saved
1	\$100
2	\$150
3	\$225
4	\$337.50
5	\$506.25

Countdown to TAKS

24 Weeks to TAKS

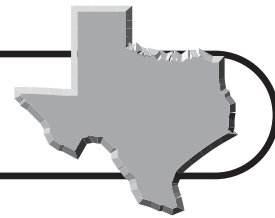

Monday

1 Petra is using square tiles to model an arithmetic sequence. What is the common difference of her sequence? **(7.4)(C)**

- A 1
- B 3
- C 5
- D 7

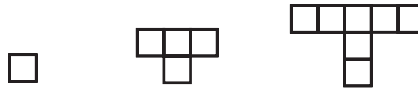

Tuesday

2 The highest point in Texas is Guadalupe Peak. If you subtract 1,247 feet from three times the elevation of this point, the result is 25,000 feet. Write an equation that can be used to solve for the height of Guadalupe Peak. **(7.5)(B)**

- F $3(x + 1,247) = 25,000$
- G $3(x - 1,247) = 25,000$
- H $3x + 1,247 = 25,000$
- J $3x - 1,247 = 25,000$

Wednesday

3 Use the equation that you wrote in Exercise 2 to solve for the elevation of Guadalupe Peak. **(7.5)(A)**

- A 7,918 ft
- B 8,306 ft
- C 8,749 ft
- D 8,874 ft

Thursday

4 The table shows how far a lion can run in different amounts of time. What is the missing value in the table? **(7.3)(B)**

Time	Distance
5 sec	350 ft
10 sec	700 ft
15 sec	1,050 ft
20 sec	1,400 ft
25 sec	1,750 ft
30 sec	?

- F 2,050 ft
- G 2,100 ft
- H 2,200 ft
- J 2,450 ft

Friday

5 Which of the following shows the numbers in order from least to greatest? **(7.1)(A)**

- A $4^2, 3^3, 8^2, 5^3$
- B $4^2, 3^3, 5^3, 8^2$
- C $3^3, 4^2, 8^2, 5^3$
- D $3^3, 4^2, 5^3, 8^2$

Countdown to TAKS

23 Weeks to TAKS

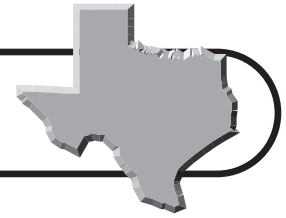

Monday

- 1 The record low temperatures for several states are shown in the table. Which of the following shows these temperatures in order from least to greatest? **(7.1)(A)**

State	Record Low Temperature
AK	-80°F
FL	-2°F
OH	-39°F
TX	-23°F

- A** $-2, -23, -39, -80$
B $-2, -39, -23, -80$
C $-80, -23, -39, -2$
D $-80, -39, -23, -2$

Tuesday

- 2 What are the coordinates of point B ? **(7.7)(A)**

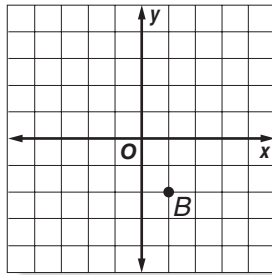

- F** $B(2, -1)$
G $B(-2, 1)$
H $B(1, -2)$
J $B(-1, 2)$

Wednesday

- 3 A submarine dives 240 meters below the surface of the water and then rises 65 meters. Which integer describes the position of the submarine in relation to the surface of the water? **(7.2)(C)**

- A** -305
B -175
C 175
D 305

Thursday

- 4 Rock 'n' roll legend Roy Orbison was born in Vernon, TX, in 1936. He died in 1988. How old was the famous singer and songwriter when he died? **(7.2)(C)**

- F** 52 yr
G 55 yr
H 62 yr
J 67 yr

Friday

- 5 There are about 7.3×10^3 acres of state forests in Texas. How can you write this number in standard form? **(7.2)(E)**

- A** 73 ac
B 730 ac
C 7,300 ac
D 73,000 ac

Countdown to TAKS

22 Weeks to TAKS

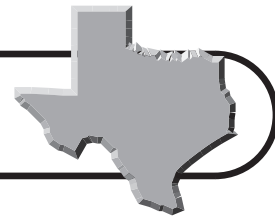

Monday

1 Aaron is making a map of his hometown on a coordinate grid. What are the coordinates of the school? **(7.7)(A)**

- A $(-4, 5)$
- B $(4, -5)$
- C $(-5, -4)$
- D $(5, -4)$

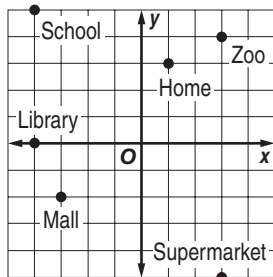

Tuesday

2 What is the value of $3abc$ if $a = 2$, $b = -5$, and $c = -3$? **(7.2)(G)**

- F -90
- G -30
- H 30
- J 90

Wednesday

3 At a car wash fundraiser, the director estimates that each group of 4 students can wash 8 cars per hour. If there are 20 student volunteers, how many cars can the group wash in 6 hours? **(7.7)(F)**

- A 192 cars
- B 225 cars
- C 240 cars
- D 480 cars

Thursday

4 The state of Texas has 591 kilometers of coastline. How many meters of coastline does the state have? **(7.3)(B)**

- F 591 m
- G 5,910 m
- H 59,100 m
- J 591,000 m

Friday

5 What are the coordinates of the point that is 4 units to the left and 2 units below the origin? **(7.7)(A)**

- A $(-4, 2)$
- B $(-4, -2)$
- C $(-2, -4)$
- D $(-2, 4)$

Countdown to TAKS

21 Weeks to TAKS

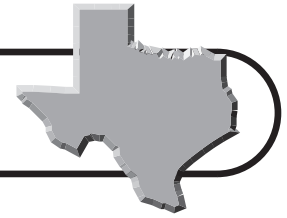

Monday

1 The United States Capitol building was originally built in 1793. It has housed the Senate and the House of Representatives for over 200 years. What is the height of the building in kilometers? **(7.3)(B)**

- A** 0.088 km
- B** 0.88 km
- C** 8,800 km
- D** 88,000 km

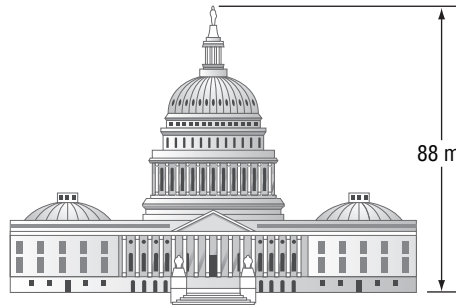

Tuesday

2 Texas is the second largest state in America with an area of about 268,000 square miles. How can you write this number using scientific notation? **(7.2)(E)**

- F** 2.68×10^4
- G** 2.68×10^5
- H** 2.68×10^6
- J** 2.68×10^7

Wednesday

3 Which of the following integers has the largest absolute value? **(7.1)(A)**

- A** -99
- B** -38
- C** 75
- D** 101

Thursday

4 Which of the following symbols will make a true number sentence when placed in the blank? **(7.1)(A)**

$$0 \text{ ____ } -5$$

- F** >
- G** <
- H** =
- J** +

Friday

5 A carpenter needs a 1.6-meter length of wood for a project. How many centimeters should the carpenter cut off of a 2-meter long board? **(7.3)(B)**

- A** 0.4 cm
- B** 4 cm
- C** 40 cm
- D** 400 cm

Countdown to TAKS

20 Weeks to TAKS

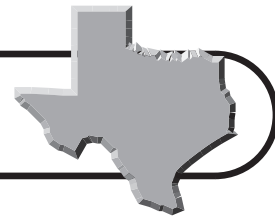

Monday

- 1** The coordinate grid shows the locations of different areas on the school playground. Suppose you leave the school and travel 8 units up and 2 units right. Then you travel 1 unit up and 7 units right. Finally, you travel 2 units left and 9 units down. What is your final location? **(7.7)(A)**

- A** four-square
- B** monkey bars
- C** swing set
- D** tether ball

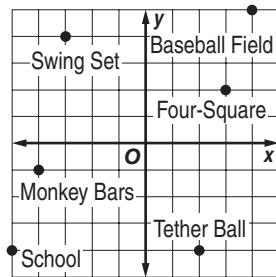

Tuesday

- 2** Guadalupe Peak is the highest point in Texas at an elevation of 2,667 meters. What is the elevation of Guadalupe Peak in kilometers? **(7.3)(B)**

- F** 0.2667 km
- G** 2.667 km
- H** 26.67 km
- J** 266.7 km

Wednesday

- 3** Steve earns \$7.60 per hour at a department store. At this rate, how much would he earn for working a 6.5-hour shift? **(7.2)(B)**

- A** \$45.15
- B** \$49.40
- C** \$53.25
- D** \$56.80

Thursday

- 4** A giraffe can run at speeds up to about 46.9 feet per second. At this rate, how long would it take a giraffe to run 117.25 feet? **(7.2)(B)**

- F** 1.5 sec
- G** 2 sec
- H** 2.5 sec
- J** 3 sec

Friday

- 5** Three less than the product of a number and 2 is 33. What is the number?

- (7.2)(F)**
- A** 18
 - B** 20
 - C** 23
 - D** 25

Countdown to TAKS

19 Weeks to TAKS

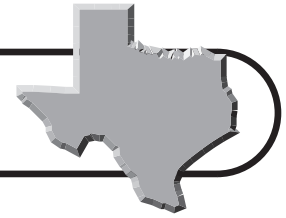

Monday

- 1** The function $h(t) = -16t^2 + 64t$ shows the height of a soccer ball t seconds after it was kicked up into the air. What is the maximum height of the ball? **(7.2)(G)**

- A** 4 ft
B 16 ft
C 32 ft
D 64 ft

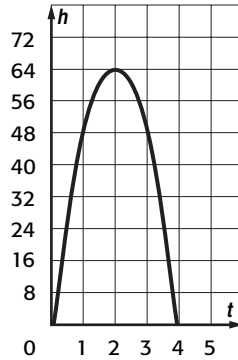

Tuesday

- 2** If an airplane travels 1,050 miles in 1 hour and 45 minutes, what is the average speed of the plane in miles per hour? Use the formula $d = rt$. **(7.2)(D)**

- F** 520 mph **H** 580 mph
G 550 mph **J** 600 mph

Wednesday

- 3** Tri has saved \$65 so far toward a new stereo system. The system costs \$185. If Tri plans to save an additional \$20 each week, for how many more weeks will he need to save? **(7.5)(A)**

- A** 4 wk **C** 6 wk
B 5 wk **D** 7 wk

Thursday

- 4** The distance from Amarillo to Lubbock, along I-27, is 124 miles. If Tyrone drives from Amarillo to Lubbock in 2 hours, what is his average speed in miles per hour? Use the formula $d = rt$. **(7.2)(D)**

0	0	0	0	.	0	0
1	1	1	1		1	1
2	2	2	2		2	2
3	3	3	3		3	3
4	4	4	4		4	4
5	5	5	5		5	5
6	6	6	6		6	6
7	7	7	7		7	7
8	8	8	8		8	8
9	9	9	9		9	9

Friday

- 5** Four more than the product of a number and 5 is 49. What is the number? **(7.2)(F)**

- F** 3
G 7
H 9
J 10

Countdown to TAKS

18 Weeks to TAKS

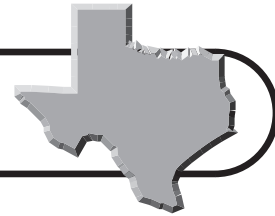

Monday

- 1 The table shows how much money Keith earns for walking different numbers of dogs after school. What is the missing value in the table? **(7.3)(B)**

Number of Days	Amount Earned
2	\$15
4	\$30
6	?
8	\$60
10	\$75

- A** \$32
B \$35
C \$40
D \$45

Tuesday

- 2 Amanda earns \$8 for each hour that she baby-sits. How many hours does she have to baby-sit to earn \$56? **(7.2)(F)**

- F** 8 h
G 7 h
H 6 h
J 5 h

Wednesday

- 3 The sum of the measures of the angles of a triangle is 180° . What is the missing measure in the figure below? **(7.13)(B)**

- A** 54°
B 59°
C 64°
D 67°

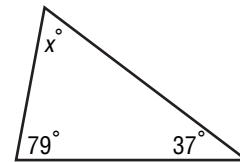

Thursday

- 4 If you add 46 to the number of counties in the state of Texas, the result is 300. How many counties are there in Texas? **(7.2)(C)**

- F** 254
G 276
H 324
J 346

Friday

- 5 When a number is multiplied by -6 , the result is -108 . What is the number? **(7.5)(B)**

- A** 22
B 18
C -18
D -22

Countdown to TAKS

17 Weeks to TAKS

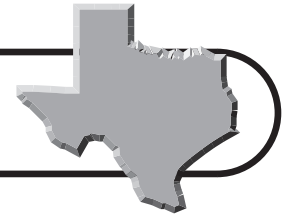

Monday

1 What fraction is modeled by the grid? **(7.2)(A)**

A $\frac{3}{5}$

B $\frac{33}{50}$

C $\frac{18}{25}$

D $\frac{11}{15}$

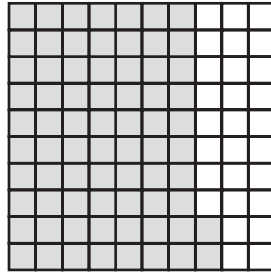

Tuesday

2 In a survey, 33 out of 46 seventh-graders said that they have homework at least 4 nights a week. How can you write this fraction as a decimal to the nearest hundredth? **(7.1)(B)**

F 0.64

G 0.72

H 0.76

J 0.83

Wednesday

3 Texas covers an area of about 270,000 square miles. This includes about 6,750 square miles of inland water. What percent of the state is covered by water? **(7.3)(A)**

A 2.5%

B 3%

C 4.5%

D 5%

Thursday

4 Emily practiced the piano for 2 hours and 36 minutes last week. How can you write the total time she spent practicing as a decimal? **(7.2)(B)**

F 2.2 h

G 2.3 h

H 2.4 h

J 2.6 h

Friday

5 Which of the following percents represents 0.015? **(7.1)(B)**

A 0.15%

B 1.5%

C 15%

D 150%

Countdown to TAKS

16 Weeks to TAKS

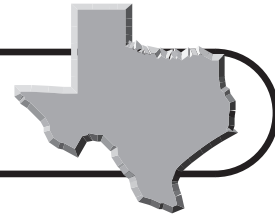

Monday

- 1** The table shows the number of shots taken and made by the seventh-grade basketball team during their first 5 games. What was the lowest success rate during these games? Round to the nearest tenth if necessary. **(7.1)(B)**

- A** 40.8%
B 41.5%
C 41.9%
D 42.2%

Attempted Shots	Made Shots
48	21
51	25
55	30
45	19
52	24

Tuesday

- 2** How can you express the shaded portion of the rectangle as a decimal? **(7.2)(B)**

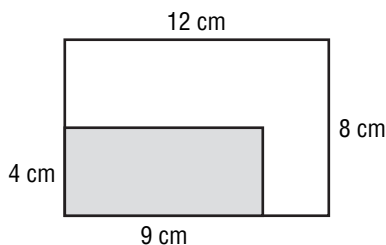

- F** 0.25
G 0.3125
H 0.35
J 0.375

Wednesday

- 3** A carpenter has drill bits of different sizes in a toolbox. Which of the following shows the bits in order from smallest to largest? **(7.1)(A)**

- A** $\frac{11}{32}$ -in., $\frac{1}{4}$ -in., $\frac{5}{16}$ -in., $\frac{3}{8}$ -in.
B $\frac{1}{4}$ -in., $\frac{3}{8}$ -in., $\frac{5}{16}$ -in., $\frac{11}{32}$ -in.
C $\frac{1}{4}$ -in., $\frac{5}{16}$ -in., $\frac{11}{32}$ -in., $\frac{3}{8}$ -in.
D $\frac{5}{16}$ -in., $\frac{1}{4}$ -in., $\frac{11}{32}$ -in., $\frac{3}{8}$ -in.

Thursday

- 4** Valeria can type 40 words per minute. At this rate, how long would it take her to type 200 words? **(7.2)(F)**

- F** 4 min
G 5 min
H 6 min
J 7 min

Friday

- 5** The population of Texas is about 22 million people. About 2 million of these people are age 65 or older. What percent of the population of Texas is age 65 or older? Round to the nearest tenth. **(7.1)(B)**

- A** 9.1%
B 12.4%
C 14.5%
D 15.3%

Countdown to TAKS

15 Weeks to TAKS

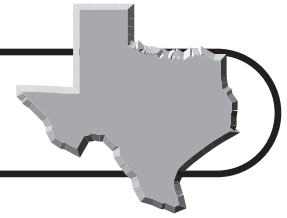

Monday

- 1** Mrs. Rodriguez measured the Texas flag hanging in her classroom. How much material was used to make the flag? **(7.8)(C)**

A $10\frac{2}{3}$ ft²

B $11\frac{1}{2}$ ft²

C $11\frac{3}{4}$ ft²

D $12\frac{1}{3}$ ft²

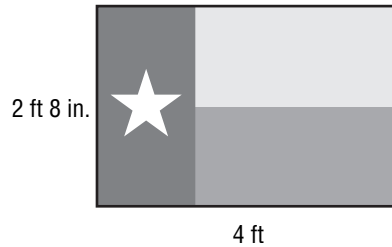

Tuesday

- 2** Add the mixed numbers $4\frac{1}{9} + 3\frac{8}{9}$. **(7.2)(B)**

F 7

G $7\frac{4}{9}$

H $7\frac{7}{9}$

J 8

Wednesday

- 3** Suppose there are 5 out of 8 slices of pizza remaining. If two friends each take half of the remaining pizza, what fraction of the whole pizza does each one receive? **(7.2)(B)**

A $\frac{3}{16}$

B $\frac{5}{16}$

C $\frac{1}{2}$

D $\frac{5}{8}$

Thursday

- 4** The weight in pounds p of an object with a mass m of 40 kilograms is given by the equation $\frac{p}{m} = 2.2$. What is the object's weight in pounds? **(7.5)(B)**

F 18.2 lb

G 44 lb

H 66 lb

J 88 lb

Friday

- 5** What is $\frac{14}{25}$ divided by $\frac{2}{25}$? **(7.2)(B)**

A 5

B 6

C 7

D 8

Countdown to TAKS

14 Weeks to TAKS

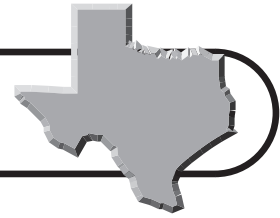

Monday

1 The length of the flag is $1\frac{1}{3}$ times the width. What is the width of the flag? **(7.13)(C)**

A $4\frac{1}{8}$ ft

B $4\frac{1}{3}$ ft

C $6\frac{3}{4}$ ft

D $7\frac{1}{3}$ ft

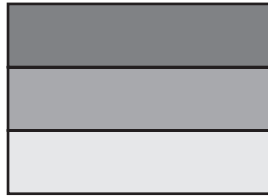

$5\frac{1}{2}$ ft

Tuesday

2 The average precipitation for July and August in El Paso, is $1\frac{1}{2}$ inches and $1\frac{3}{4}$ inches, respectively. What is the total average precipitation for these two months? **(7.2)(B)**

F 3 in.

G $3\frac{1}{4}$ in.

H $3\frac{3}{8}$ in.

J 4 in.

Wednesday

3 What number sentence is shown in the model? **(7.2)(A)**

A $\frac{1}{3} \times \frac{1}{2} = \frac{1}{6}$

B $\frac{1}{4} \times \frac{1}{3} = \frac{1}{12}$

C $\frac{1}{4} \times \frac{1}{2} = \frac{1}{8}$

D $\frac{3}{4} \times \frac{1}{2} = \frac{3}{9}$



Thursday

4 Reggie can swim 1.2 laps per minute. At this rate, how long will it take him to swim 18 laps? **(7.2)(F)**

F 8 min

G 10 min

H 12 min

J 15 min

Friday

5 Which of the following percents represents 1.45? **(7.1)(B)**

A 145%

B 14.5%

C 1.45%

D 0.145%

Countdown to TAKS

13 Weeks to TAKS

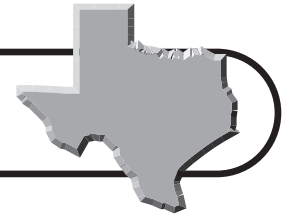

Monday

1 Suzie is making a scale drawing of her room. If each inch represents 1.5 feet, what are the actual dimensions of Suzie's room? **(7.3)(B)**

- A** 10 ft by 12 ft
- B** 12 ft by 15 ft
- C** 12 ft by 16 ft
- D** 14 ft by 16 ft

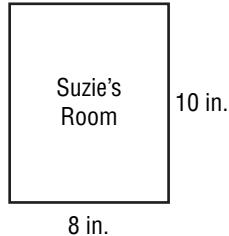

Tuesday

2 The Fred Hartman Bridge allows Texas State Road 146 to cross the Houston ship channel. The bridge is 0.237 mile long. How many feet long is the bridge? **(7.3)(B)**

0	0	0	0	.	0	0
1	1	1	1		1	1
2	2	2	2		2	2
3	3	3	3		3	3
4	4	4	4		4	4
5	5	5	5		5	5
6	6	6	6		6	6
7	7	7	7		7	7
8	8	8	8		8	8
9	9	9	9		9	9

Wednesday

3 A grocery store sells 3 pounds of mixed nuts for \$11.49. What is the unit price? **(7.2)(D)**

- F** \$3.49/lb
- G** \$3.57/lb
- H** \$3.83/lb
- J** \$3.95/lb

Thursday

4 How many ounces are there in a 3-pound bag of apples? **(7.3)(B)**

- A** 36 oz
- B** 42 oz
- C** 48 oz
- D** 56 oz

Friday

5 Which of the following represents the best buy for aspirin? **(7.2)(G)**

- F** 50 for \$5.10
- G** 75 for \$6.55
- H** 90 for \$7.75
- J** 100 for \$8.49

Countdown to TAKS

12 Weeks to TAKS

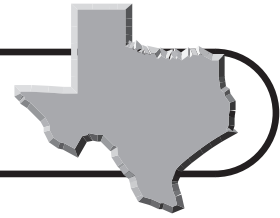

Monday

- 1** The table shows the number of student volunteers representing each grade at a community fundraiser. It also shows how much money was raised by each grade. Which grade had the highest rate of money raised per student? **(7.2)(D)**

Grade	Number of Students	Amount Raised
5th	25	\$800
6th	30	\$900
7th	28	\$980
8th	26	\$754

- A** 5th graders
B 6th graders
C 7th graders
D 8th graders

Tuesday

- 2** Antonio scored 14 points in his last basketball game. If his team scored 56 points altogether, which ratio compares Antonio's points to the team's points? **(7.14)(A)**

- F** 1:3
G 1:3.5
H 1:4
J 1:4.5

Wednesday

- 3** The population of Texas is about 21.9 million people. The population of Houston is about 1.9 million people. What percent of the population of Texas is made up of Houston residents? Round to the nearest tenth. **(7.3)(A)**

- A** 7.9%
B 8.7%
C 9.4%
D 9.8%

Thursday

- 4** An ink jet printer can print 15 pages in 3 minutes. At this rate, how long would it take to print a 45-page report? **(7.3)(B)**

- F** 3 min
G 6 min
H 9 min
J 12 min

Friday

- 5** What is the ratio of shaded squares to non-shaded squares? **(7.14)(A)**

- A** 2 to 3
B 2 to 5
C 3 to 5
D 3 to 10

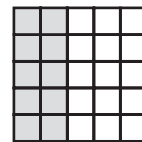

Countdown to TAKS

11 Weeks to TAKS

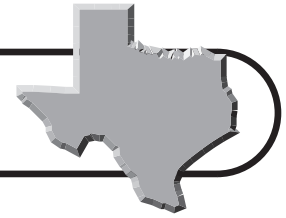

Monday

- 1** The table shows the approximate population of Texas during different years of the U.S. Census. What was the percent increase in population from 1900 to 2000? **(7.3)(A)**

Population of Texas

Year	Population
1850	200,000
1900	3,000,000
1950	8,000,000
2000	21,000,000

- A** 60%
B 70%
C 600%
D 700%

Tuesday

- 2** Tamara can read 9 pages in 6 minutes. At this rate, how long would it take her to read 30 pages? **(7.3)(B)**

- F** 15 min
G 16 min
H 18 min
J 20 min

Wednesday

- 3** A computer monitor that regularly sells for \$280 is on sale for 20% off. What is the sale price of the monitor? **(7.3)(A)**

0	0	0	0	.	0	0
1	1	1	1		1	1
2	2	2	2		2	2
3	3	3	3		3	3
4	4	4	4		4	4
5	5	5	5		5	5
6	6	6	6		6	6
7	7	7	7		7	7
8	8	8	8		8	8
9	9	9	9		9	9

Thursday

- 4** Suppose \$1,500 is invested in a CD for 3 years at a simple interest rate of 4.5%. How much will the CD be worth after 3 years? **(7.13)(A)**

- A** \$1,680.25
B \$1,702.50
C \$1,715.90
D \$1,742.75

Friday

- 5** Christy's haircut cost \$24.95. She wants to leave a 15% tip. About how much of a tip should she leave? **(7.3)(A)**

- F** \$2.50
G \$3.50
H \$3.75
J \$4.90

Countdown to TAKS

10 Weeks to TAKS

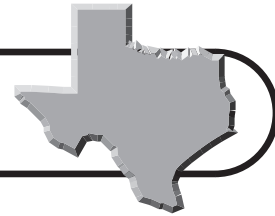

Monday

- 1** The circle graph shows the three main elements in the human body. If Martin weighs 150 pounds, how many pounds of carbon are in his body? **(7.3)(A)**

- A** 15 lb
- B** 19 lb
- C** 27 lb
- D** 32 lb

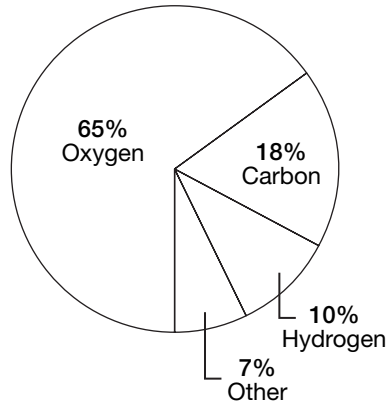

Tuesday

- 2** Which of the following is the best estimate for $\frac{1}{4}\%$ of 794? **(7.3)(A)**

- F** 1
- G** 2
- H** 4
- J** 8

Wednesday

- 3** A barbecue grill originally priced at \$180 is on sale for \$135. What percent of the original cost is the sale price? **(7.3)(A)**

- A** 25%
- B** 30%
- C** 70%
- D** 75%

Thursday

- 4** On average, Houston has 106 days each year with precipitation. What percent of the year (365 days) does Houston have precipitation? Round to the nearest whole number. **(7.3)(A)**

- F** 25%
- G** 29%
- H** 32%
- J** 35%

Friday

- 5** In a survey, 22% of teens said they have a computer in their room. If there are 15,000 teens living in a county, predict how many of them have a computer in their room. **(7.11)(B)**

- A** 3,300
- B** 3,500
- C** 3,750
- D** 3,975

Countdown to TAKS

9 Weeks to TAKS

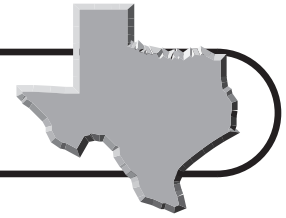

Monday

- 1 The bar graph shows the results of a survey on favorite types of music. How many more people said that they prefer hip hop music to classical music? **(7.11)(B)**

- A** 5
B 10
C 15
D 25

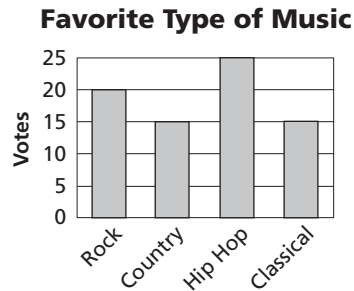

Tuesday

- 2 What is the mean number of books read in the line plot? **(7.12)(A)**

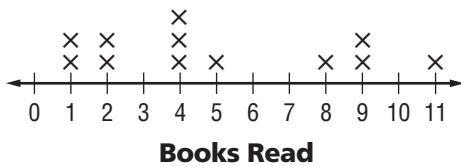

- F** 5 books
G 5.2 books
H 5.5 books
J 6 books

Wednesday

- 3 Pablo's test scores this quarter are 79, 88, 84, and 88. Which of the following measures makes his typical test score appear as high as possible? **(7.12)(A)**

- A** Mean
B Median
C Mode
D Range

Thursday

- 4 In Exercise 2, what is the range in the number of books read? **(7.12)(A)**

- F** 1 book
G 4 books
H 7 books
J 10 books

Friday

- 5 Each year, Texas farmers raise about \$880 million from chickens, \$766 million from dairy products, \$257 million from chicken eggs, and \$114 million from hogs. Which data display would be most appropriate to show this information? **(7.11)(A)**

- A** Bar graph
B Circle graph
C Line graph
D Line plot

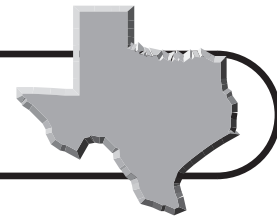

Countdown to TAKS

8 Weeks to TAKS

Monday

1 The line plot shows the number of absent students during different weeks of the school year. Which of the following measures best represents the number of absent students per week? (7.12)(B)

- A Mean
- B Median
- C Mode
- D Range

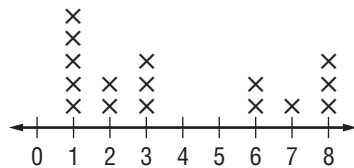

Absent Students

Tuesday

2 What is the median population density (people per square mile) for the five Texas counties shown? (7.12)(A)

County	People Per Square Mile
Anderson	51.5
Bowie	100.6
Gaines	9.6
Liberty	60.5
Parker	97.9

- F 51.5
- G 60.5
- H 64
- J 91

Wednesday

3 The Venn diagram shows how many students are acting in the play and singing in the school choir. How many students perform in both activities? (7.11)(A)

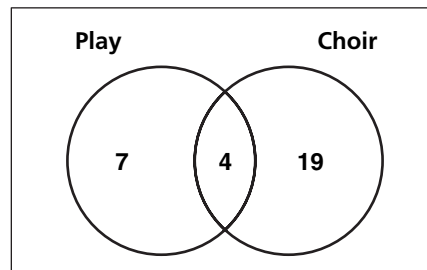

- A 4 students
- B 5 students
- C 7 students
- D 11 students

Thursday

4 Which of the following is the best estimate for $\frac{1}{2}\%$ of 404? (7.3)(A)

- F 0.5
- G 1
- H 2
- J 4

Friday

5 Which of the following types of data displays is most appropriate for showing how much you have grown over the past two years? (7.11)(A)

- A Bar graph
- B Circle graph
- C Histogram
- D Line graph

Countdown to TAKS

7 Weeks to TAKS

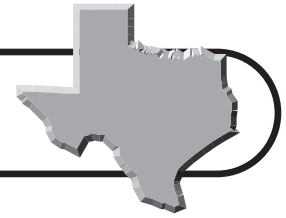

Monday

- 1** Paulie's family is making pizza. They can choose from thin or thick crust. The topping choices are pepperoni or sausage. Which list shows all possible outcomes? **(7.10)(A)**

A

Outcomes	
thin	pepperoni
thick	pepperoni
thin	sausage
thick	sausage

C

Outcomes	
thin	sausage
thick	pepperoni
thin	sausage
thick	pepperoni

B

Outcomes	
thin	pepperoni
thin	sausage
thick	pepperoni

D

Outcomes	
thin	sausage
thick	pepperoni
thick	sausage

Tuesday

- 2** To play a board game, players must roll a number cube and spin the spinner below. How many possible outcomes are there on each turn? **(7.10)(A)**

- F** 12
G 15
H 20
J 24

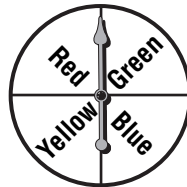

Wednesday

- 3** Mr. Thomas gave a quiz to his math students. The scores were 9, 8, 3, 5, 5, 10, and 6. What is the median score? **(7.12)(B)**

- A** 5
B 6
C 7
D 8

Thursday

- 4** There are 210 seats in a movie theater. If 60% of the seats are filled, how many people are sitting in the movie theater? **(7.3)(A)**

- F** 150
G 145
H 130
J 126

Friday

- 5** If you choose a vowel and toss a coin, how many possible outcomes are there in the sample space? **(7.10)(A)**

- A** 5
B 10
C 12
D 16

Countdown to TAKS

6 Weeks to TAKS

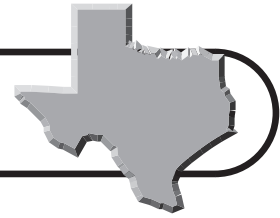

Monday

1 The line graph shows the overnight low temperatures on five consecutive days. What is the mean low temperature for the days shown? **(7.12)(A)**

- A 8°F
- B 9°F
- C 10°F
- D 11°F

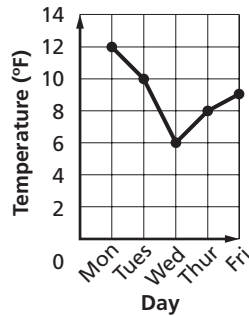

Tuesday

2 A set of 25 playing cards is numbered 1, 2, 3, 4, 5, ..., 25. What is the median number? **(7.12)(B)**

- F 10
- G 11
- H 12
- J 13

Wednesday

3 Christine needs to choose between brown, blue, and white socks with either boots, gym shoes, dress shoes, or loafers. How many different outcomes are possible? **(7.10)(A)**

- A 9
- B 10
- C 12
- D 15

Thursday

4 East Texas is made up of 49 counties and covers about 40,000 square miles. What is the average area of an East Texas county? Round your answer to the nearest whole number. **(7.12)(A)**

- F 816 mi²
- G 825 mi²
- H 839 mi²
- J 845 mi²

Friday

5 Which list shows the following integers in order from least to greatest? **(7.1)(A)**

2, -12, 6, -6, 3, -5

- A -5, -6, -12, 2, 3, 6
- B -12, -6, -5, 2, 3, 6
- C 6, 3, 2, -5, -6, -12
- D -12, -6, -5, 6, 3, 2

Countdown to TAKS

5 Weeks to TAKS

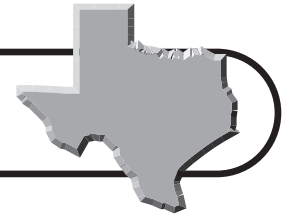

Monday

- 1** Which of the following terms best describes the relationship between the angles? **(7.16)(A)**
- A** Adjacent
 - B** Complementary
 - C** Supplementary
 - D** Vertical

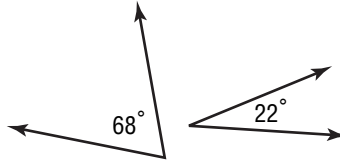

Tuesday

- 2** The population of Dallas is about 1,200,000. About 9.5% of these people are children under 5 years of age. If you were to make a circle graph of the different age groups, how many degrees would you make the sector for under 5 years? **(7.13)(B)**
- F** 22.9°
 - G** 30.6°
 - H** 34.2°
 - J** 45.5°

Wednesday

- 3** Which of the following terms best describes the triangle below? **(7.16)(B)**



- A** Equilateral
- B** Isosceles
- C** Right
- D** Scalene

Thursday

- 4** Which of the following terms best describes a parallelogram with four right angles? **(7.6)(B)**
- F** Quadrilateral
 - G** Rectangle
 - H** Square
 - J** Trapezoid

Friday

- 5** Which of the following statements is always true about two similar figures? **(7.6)(D)**
- A** Corresponding angles are congruent
 - B** Corresponding sides are congruent
 - C** Opposite angles are complementary
 - D** Opposite sides are parallel

Countdown to TAKS

4 Weeks to Weeks

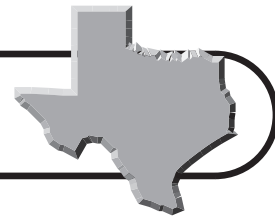

Monday

1 The two triangles at the right are similar. What is the value of x ? (7.6)(D)

- A 9 cm
- B 8 cm
- C 7 cm
- D 6 cm

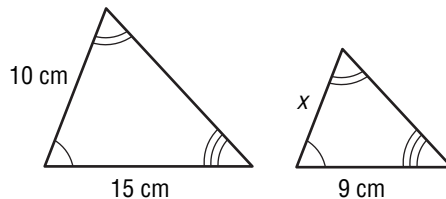

Tuesday

2 About 7 out of 20 Texas citizens live in a renter-occupied housing unit. How can you express this as a percent? (7.3)(B)

- F 25%
- G 30%
- H 35%
- J 40%

Wednesday

3 What number sentence does the model represent? (7.1)(C)

- A $4^2 = 16$
- B $5^2 = 25$
- C $6^2 = 36$
- D $7^2 = 49$

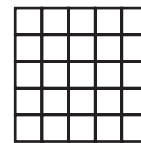

Thursday

4 Which of the following terms best describes the two angles below? (7.6)(A)

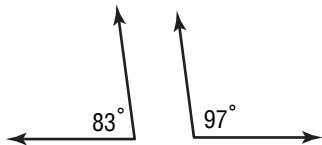

- F adjacent
- G complementary
- H obtuse
- J supplementary

Friday

5 If the triangle is reflected across the y -axis, what will the coordinates of point C' be? (7.7)(B)

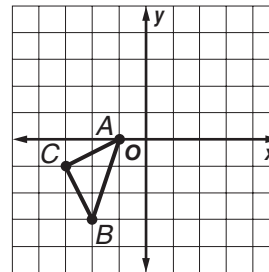

- A $C'(1, 0)$
- B $C'(3, -1)$
- C $C'(-3, -1)$
- D $C'(-3, 1)$

Countdown to TAKS

3 Weeks to TAKS

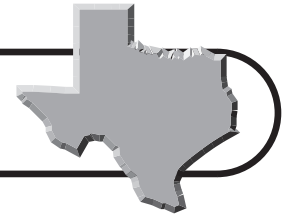

Monday

- 1** Ming is having carpet installed in her family room. If she also wants to have baseboard installed around the perimeter of the room, how many feet will she need? **(7.9)(A)**

- A** 22 ft
B 44 ft
C 88 ft
D 96 ft

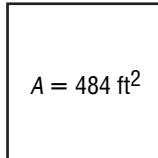

Tuesday

- 2** What will the coordinates of point R' be if the triangle is reflected across the x -axis? **(7.7)(B)**

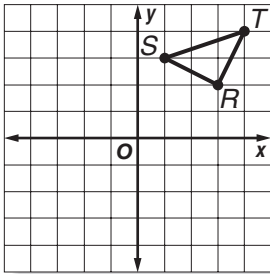

- F** $R'(-2, -3)$
G $R'(3, -2)$
H $R'(2, -3)$
J $R'(-3, -2)$

Wednesday

- 3** What is the circumference of an ice skating rink with a radius of 30 yards? Use 3.14 for π . Round your answer to the nearest tenth. **(7.9)(A)**

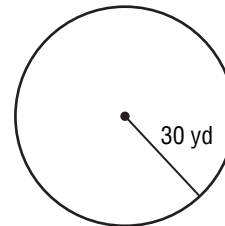

- A** 172.1 yd
B 188.4 yd
C 205.5 yd
D 212.4 yd

Thursday

- 4** The Texas Rangers play at Ameriquest Field in Arlington. Which of the following best describes the infield of the ballpark shown below? **(7.6)(B)**

- F** Parallelogram
G Rectangle
H Rhombus
J Square

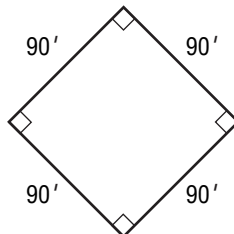

Friday

- 5** Suppose quadrilateral $QRST$ is dilated about point Q with a scale factor of 2. Which of the following expressions can be used to find the length of segment $S'T'$? **(7.4)(A)**

- A** $4 \cdot ST$
B $2 \cdot ST$
C $0.5 \cdot ST$
D $0.25 \cdot ST$

Countdown to TAKS

2 Weeks to TAKS

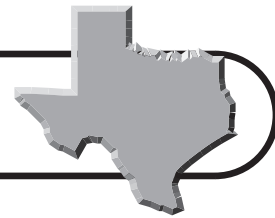

Monday

- 1** The table shows the volumes, in cubic units, of cubes with different side lengths. What is the side length of a cube with a volume of 512 cubic units? **(7.4)(B)**

A 7 units
B 8 units
C 9 units
D 10 units

Side Length	Volume
1	1
2	8
3	27
4	64
5	125
6	216

Tuesday

- 2** The distance from Odessa to Abilene along Interstate 20 is about 170 miles. If there are about 1.61 kilometers per mile, what is the distance in kilometers? **(7.4)(A)**

F 273.7 km
G 248.9 km
H 146.2 km
J 105.6 km

Wednesday

- 3** What three-dimensional figure has the top, side, and front views shown? **(7.8)(A)**

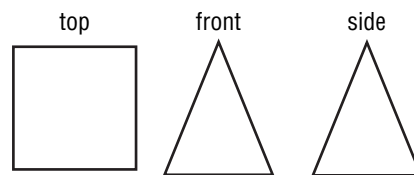

A Cone
B Cylinder
C Pyramid
D Triangular prism

Thursday

- 4** What is the surface area of the prism that has the net below? **(7.8)(B)**

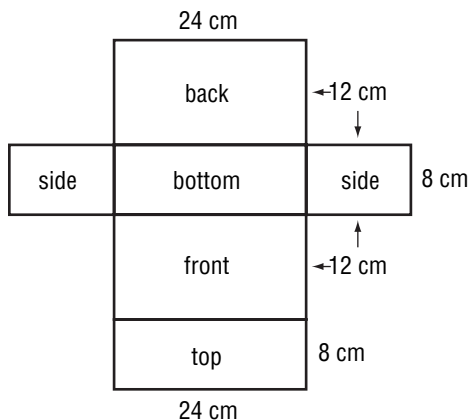

F 2,304 cm²
G 1,860 cm²
H 1,570 cm²
J 1,152 cm²

Friday

- 5** What fraction of a foot is 4 inches? **(7.2)(B)**

A $\frac{1}{6}$
B $\frac{1}{4}$
C $\frac{1}{3}$
D $\frac{1}{2}$

Countdown to TAKS

1 Weeks to TAKS

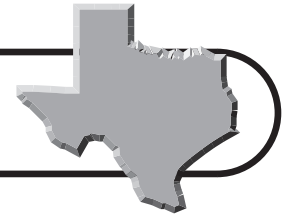

Monday

1 In this figure, the side view is 3 squares by 4 squares. The front view is 3 squares by 5 squares. Which describes the top view? **(7.8)(A)**

- A** 5 squares by 5 squares
- B** 4 squares by 5 squares
- C** 4 squares by 3 squares
- D** 4 squares by 4 squares

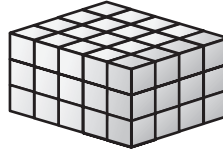

Tuesday

2 Which three-dimensional figure has a top view, side view, and front view that all look like rectangles? **(7.6)(C)**

- F** Cone
- G** Rectangular prism
- H** Rectangular pyramid
- J** Triangular prism

Wednesday

3 The Texas quarter was the 28th state quarter released, first appearing in 2004. The radius of the coin is about 12 millimeters. How far would the coin roll during 1 complete revolution? (*Hint: What is the circumference of the coin?*) Use 3.14 for π . **(7.9)(A)**

- A** 58.3 mm
- B** 65.5 mm
- C** 75.4 mm
- D** 88.1 mm



Thursday

4 Which three-dimensional figure has two circular bases? **(7.6)(C)**

- F** Cone
- G** Cylinder
- H** Square
- J** Triangular prism

Friday

5 What is the surface area of a cylinder that has a radius of 2 meters and a height of 7 meters? Use 3.14 for π . Round your answer to the nearest tenth. **(7.8)(B)**

- A** 29.3 m²
- B** 56.8 m²
- C** 72.1 m²
- D** 113.0 m²

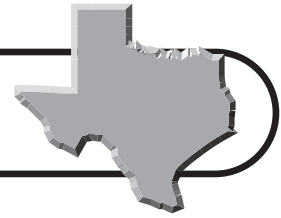

Benchmark Test 1

Read each question and choose the correct answer.

- 1** About one-fourth of the residents in Dallas were born in a foreign country. What percent of the residents of Dallas were born in a foreign country?

A 15%
B 25%
C 50%
D 66%

- 2** Which statement describes the relationship between a term and n , its position in the sequence?

Position	1	2	3	4	5	6	n
Term	0	3	8	15	24	35	

- F** Multiply n by itself.
G Multiply n by 2 and then add 2.
H Multiply n by 3 and then subtract 1.
J Multiply n by itself and then subtract 1.
- 3** Which statement is always true of a rhombus?
- A** It has exactly 1 obtuse angle.
B It has 4 parallel sides.
C It has 2 right angles.
D It has 4 equal sides.

- 4** Which net, when folded, forms a square pyramid?

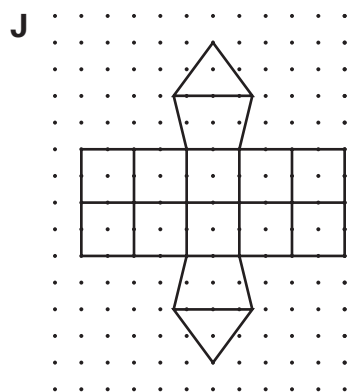
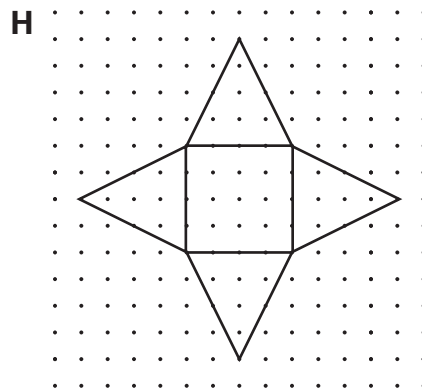
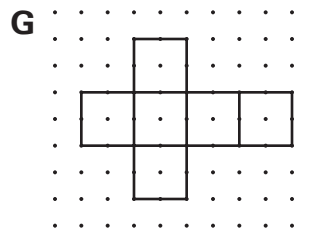
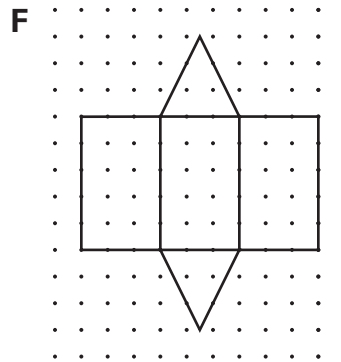

Benchmark Test 1 (continued)

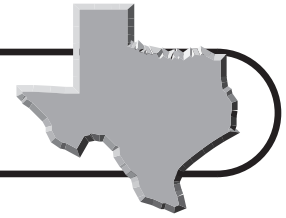

- 5 Mariah scored between 45 and 55 points in each of 6 card games. Which is the best estimate of the total points she scored in 6 games?
- A** 300
B 350
C 450
D 550

- 6 Which of the following ordered pairs is outside the circle graphed below?

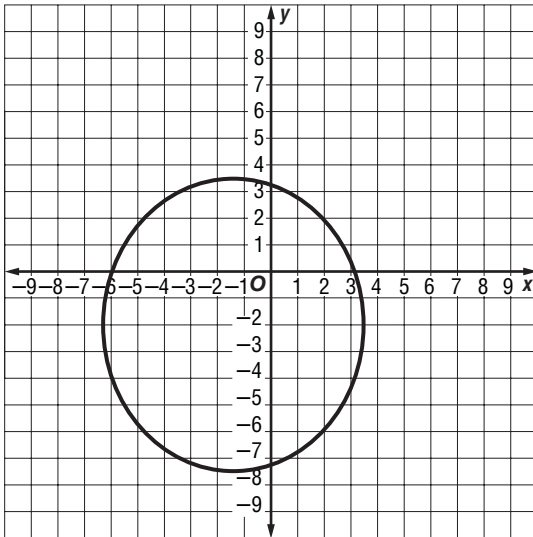

- F** $(-6, -3)$
G $(3, 0)$
H $(0, 3)$
J $(-6, 3)$
- 7 Ninety-six students and 6 teachers from Tori's school are going on a field trip. What is the student-to-teacher ratio?
- A** 16:1
B 1:16
C 6:96
D 31:3

- 8 Look at the pattern below.

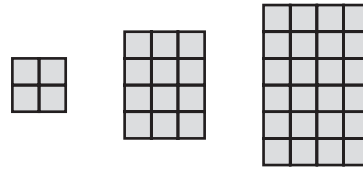

Step 1

Step 2

Step 3

How many squares will be in Step 6?

- F** 40
G 60
H 84
J 112
- 9 Shirley needs to simplify the expression $12 - 3(4 + 8)$. Which operation will she do first?
- A** Subtract 3 from 12.
B Multiply 3 by 8.
C Multiply 3 by 4.
D Add 8 and 4.
- 10 The width of the doorframe of Tito's bedroom is 80 centimeters. Its height is 215 centimeters. What is the perimeter of the door in meters?
- F** 590 m
G 59.0 m
H 5.9 m
J 0.59 m



Benchmark Test 1 (continued)

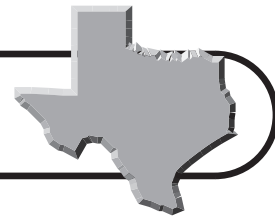

- 11** Which of these models best represents 3^2 ?

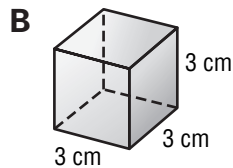
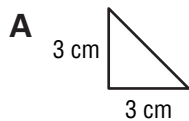

- 12** $\angle M$ and $\angle N$ are complementary angles. The measure of $\angle M$ is 33° . What is the measure of $\angle N$?

- F** 57°
G 67°
H 77°
J 147°

- 13** Which expression does the model show?

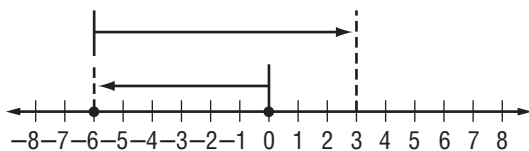

- A** $-9 - 6$
B $-9 + 6$
C $-6 - 9$
D $-6 + 9$

- 14** Mr. Vasquez is picking out tiles for his bathroom floor. Use the ruler on the Mathematics Chart to measure the sides of the tile shown below.

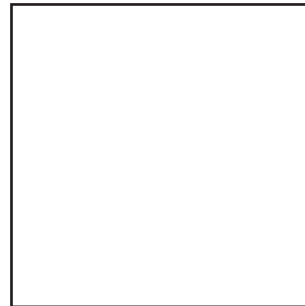

What is the area of one tile?

- F** 6 cm^2
G 16 cm^2
H 24 cm^2
J 36 cm^2

- 15** Dani made a spinner for a game. The diameter of the spinner is 12 inches. Which expression represents the circumference of the spinner?

- A** 12π
B $12 - \pi$
C $6\pi^2$
D 36π



Benchmark Test 1 (continued)

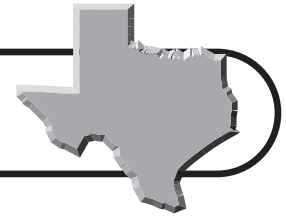

- 16** Simplify the expression below.

$$(15 - 3) \div 4 + 2^2$$

- F** 1
G 2
H 7
J 12

- 17** Which of these situations represents the greatest percent of change?

- A** A pair of shoes that was originally priced at \$50 is on sale for \$35.
B A child grew from 43 inches to 46 inches in one year.
C A car that was driving 40 miles per hour is now driving 65 miles per hour.
D A person who was working 40 hours a week is now working 24 hours a week.

- 18** Josie bought a sandwich for \$2.99, a drink for \$1.25, and a bag of crackers. She gave the cashier \$6.00. What information is needed to find how much Josie spent for lunch?

- F** The amount of change she received
G The size of the bag of crackers
H The number of crackers she bought
J The size of her drink

- 19** Tovah has 3 red scarves, 2 blue scarves, and 3 yellow scarves in her drawer. Which list shows all of the possible combinations of scarves if Tovah pulls 2 scarves at random from her drawer?

A

Scarf Combinations		
Red	Red	Red
Red	Red	Blue
Red	Blue	Blue

B

Scarf Combinations		
Red	Red	Red
Red	Red	Blue
Red	Blue	Blue

C

Scarf Combinations		
Red	Red	Red
Red	Red	Blue
Blue	Blue	Blue

D

Scarf Combinations		
Red	Red	Red
Red	Red	Blue
Red	Red	Yellow
Red	Blue	Blue



Benchmark Test 1 (continued)

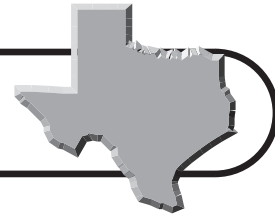

- 20** Which problem situation matches the equation $x - 4(3.35) = 1.60$?
- F** Amelia paid \$3.35 each for 4 books. She received change of \$1.60. What is x , the amount of money she gave to the cashier?
- G** Jonathan paid \$1.60 for a jar of jam that was on sale at a cost of 4 for \$3.35. What is x , the amount of change he received?
- H** Teresa ran 3.35 miles in a race with her 4 friends. The combined total time of the 5 friends was 1.6 hours. What is x , the time it took Teresa to run?
- J** Janna cut 4 pieces of yarn that were each 1.6 feet long from a piece of yarn. She had 3.35 feet of yarn leftover. What is x , the length of the original piece of yarn?

- 21** The ages of 8 young people who attended a family reunion are shown below.

15, 14, 10, 7, 17, 9, 8, 10

Which age is both the mode and the range?

- A** 7 **C** 11
B 10 **D** 17

- 22** The fraction $\frac{4}{9}$ is found between which pair of fractions on a number line?

- F** $\frac{7}{18}$ and $\frac{18}{36}$
G $\frac{8}{18}$ and $\frac{16}{36}$
H $\frac{10}{18}$ and $\frac{16}{36}$
J $\frac{11}{18}$ and $\frac{20}{36}$

- 23** A study in Texas counted the number of Monarch butterfly eggs found on milkweed plants at certain research stations. Data about the number of eggs found on milkweed plants are shown in the table.

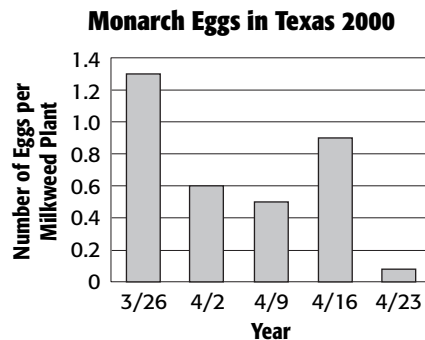

Which statement is best supported by these data?

- A** Only half as many Monarch butterfly eggs were found on April 23rd as on April 16th.
- B** More Monarchs butterflies lay eggs as the weather in Texas gets warmer.
- C** Nearly twice as many Monarch butterfly eggs were counted on April 2nd as on April 9th.
- D** More Monarch butterflies laid eggs at the beginning of April than at the end of April.
- 24** At a restaurant, Marco spent \$6.95 for his main course, \$1.20 for a drink, and \$2.25 for a dessert. The tax on the bill was 10%. If he left a 20% tip on the total bill, what is a good estimate of the tip he left?
- F** \$0.50 **H** \$4.00
G \$2.00 **J** \$8.00



Benchmark Test 1 (continued)

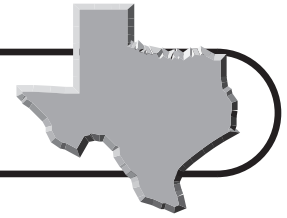

- 25** Callie matted a photo by placing a 2-inch mat over an 8×10 photo. What is the area of the photo in inches that is framed by the mat?

Record your answer and fill in the bubbles on the grid below. Be sure to use the correct place value.

				.		
0	0	0	0		0	0
1	1	1	1		1	1
2	2	2	2		2	2
3	3	3	3		3	3
4	4	4	4		4	4
5	5	5	5		5	5
6	6	6	6		6	6
7	7	7	7		7	7
8	8	8	8		8	8
9	9	9	9		9	9

- 26** Which of the following solid figures has 2 bases and 4 sides that are all congruent?

- F** Square pyramid
G Triangular pyramid
H Triangular prism
J Cube

- 27** Carlotta runs $2\frac{3}{4}$ miles every day.

How many miles does she run in a week?

- A** $13\frac{3}{4}$ mi
B $16\frac{1}{2}$ mi
C $19\frac{1}{4}$ mi
D 22 mi

- 28** The data in the table represent the relationship between the area of a circle and its radius.

Radius (cm)	Area (cm ²)
1	3.14
2	12.56
3	28.26
4	50.24

Which graph matches the data in the table above?

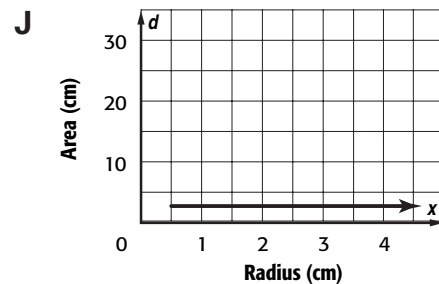
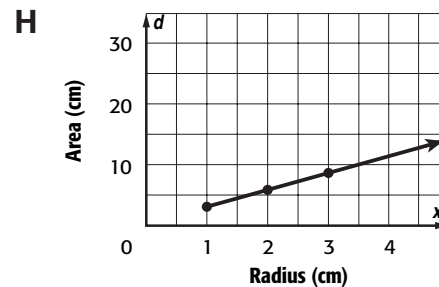
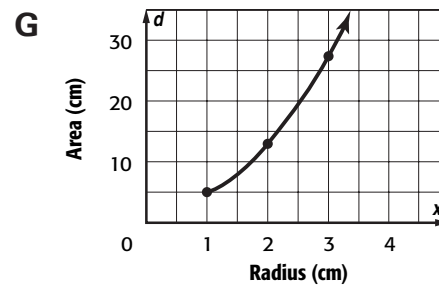
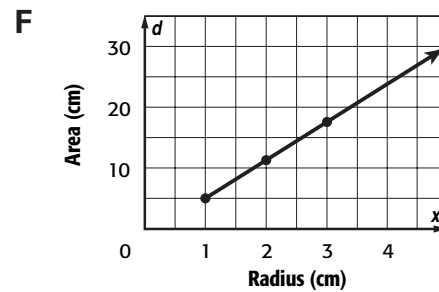

Go on

Benchmark Test 1 (continued)

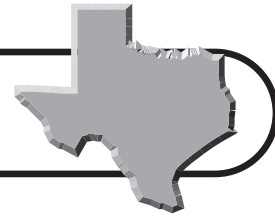

29 Members of the Drama Club bought supplies to make props for the school play. They bought 8 sheets of tag board for \$0.85 each, 3 quarts of paint for \$7.95 each, and 6 pieces of wood. The total cost was \$42.30, not including tax. Which question below cannot be answered using the information given?

- A** How much did each sheet of tag board cost?
- B** How much did each quart of paint cost?
- C** How much did the 6 pieces of wood cost?
- D** How much tax did the members pay?

30 Cedrick bought an aquarium that is 15 inches high, 10 inches wide, and 30 inches long. He wants to put a piece of cloth under the aquarium. What is the area of the cloth that he will need?

- F** 150 in²
- G** 300 in²
- H** 450 in²
- J** 3,900 in²

31 Sarah made punch for a party. She used 7 quarts of lemonade and 2 quarts of mineral water. Which equation can be used to find x , the percent of mineral water in the punch?

- A** $\frac{2}{9} = \frac{100}{x}$
- B** $\frac{2}{7} = \frac{x}{100}$
- C** $\frac{2}{7} = \frac{100}{x}$
- D** $\frac{2}{9} = \frac{x}{100}$

32 The top, side, and front views of a solid figure made of cubes are shown below.

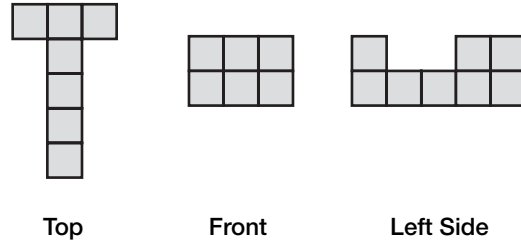

Which solid figure is represented by these views?

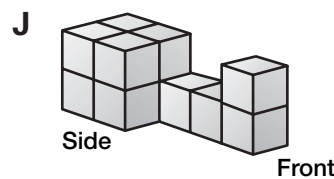
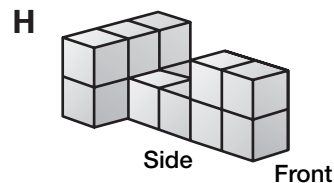
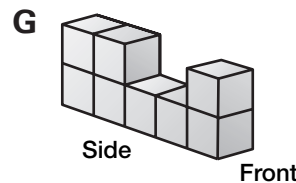
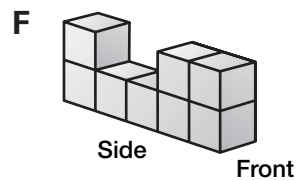

Benchmark Test 1 (continued)

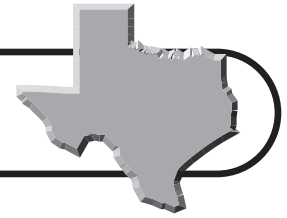

- 33** Trevor bought 2 pairs of jeans for \$21.99 each. He also bought one shirt that was priced at 3 shirts for \$15. What is the total amount he spent, not including tax, on the jeans and shirt?

A \$36.99 **C** \$48.98
B \$43.98 **D** \$58.98

- 34** Liko is making an area rug for his bedroom. He made a plan for the rug.

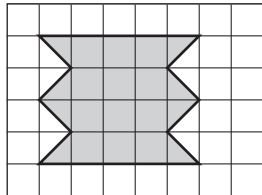

Each square on the grid represents 2 square feet. What will be the approximate area of the rug?

F 20 ft² **H** 28 ft²
G 24 ft² **J** 32 ft²

- 36** $\triangle ABC$ is similar to $\triangle PQR$. The scale factor of $\triangle ABC$ to $\triangle PQR$ is 3:2. If \overline{AB} is 18 centimeters, what is the length of \overline{PQ} ?

A 12 cm
B 18 cm
C 21 cm
D 27 cm

- 37** Rose has her MP3 music files sorted into folders based on types of music. Which graph best displays these data for comparing the number of folders in each category to the total number of folders?

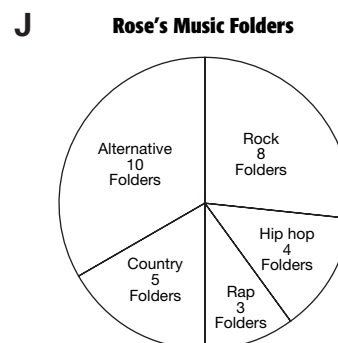
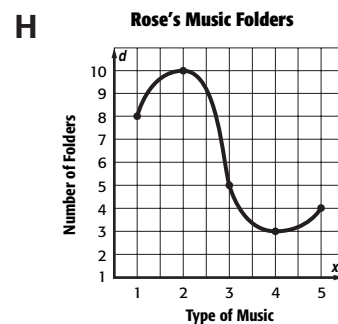
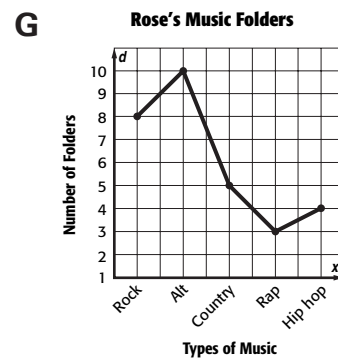
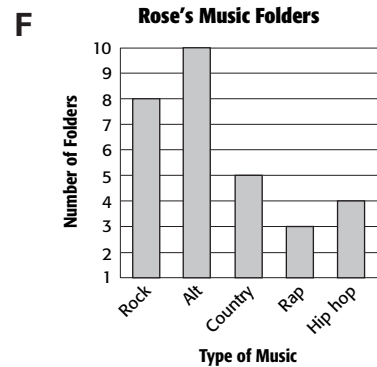

Benchmark Test 1 (continued)

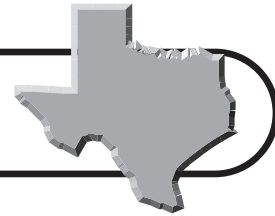

38 Shakira's math teacher gives weekly quizzes that are grade out of 20. Shakira earned a 15, 17, 14, 12, and 18 on the first five math quizzes. What must she earn on the sixth quiz for her median score to be 16?

- A** 13
- B** 15
- C** 16
- D** 18

39 Luz conducted an experiment. She tossed two coins at the same time and recorded the results. The table shows her results.

Toss	Outcome
1	HH
2	HT
3	HT
4	TT
5	TT
6	TT
7	HT
8	HH
9	HT
10	HH

What was the experimental probability of the coins both landing heads up?

- F** $\frac{1}{5}$
- G** $\frac{3}{10}$
- H** $\frac{2}{5}$
- J** $\frac{7}{10}$

40 David and his family are driving from Texarkana to Brownsville, Texas, a distance of 645 miles. Which expression can be used to find the distance David's family will drive each day if they drive equal distances over 4 days?

- A** $645 + 4$
- B** 645×4
- C** $645 \div 4$
- D** $645 - 4$

41 Kirsten is 65 inches tall. The heights of her family members are 59, 48, 65, and 72 inches. Which statistic makes it appear that Kirsten is taller than the average person in her family?

- F** Mean
- G** Median
- H** Mode
- J** Range

42 Mr. Haynes travels for his work. The table below lists the distances and the amounts of time Mr. Haynes traveled for work each day during a given week.

Day	Distance (miles)	Amount of Time (minutes)
Monday	58	65
Tuesday	104	125
Wednesday	32	45
Thursday	96	110

On which day did Mr. Haynes drive the fastest?

- A** Monday
- B** Tuesday
- C** Wednesday
- D** Thursday



Benchmark Test 1 (continued)

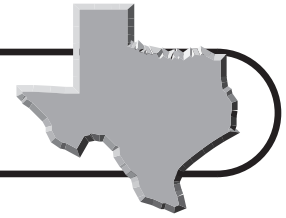

43 Which sequence follows the rule $n^2 + 4$, where n represents the position of a term in the sequence?

F 1, 5, 9, 13, 17, ...

G 1, 4, 9, 16, 25, ...

H 5, 8, 11, 14, 17, ...

J 5, 8, 13, 20, 29, ...

44 Manny is placing tape around all of the baseboard of a rectangular room before he paints the walls. The room is 13 feet long and 9 feet wide. If the doorway is 3 feet wide, how much tape will Manny need to cover all of the baseboards?

A 41 ft **C** 88 ft

B 44 ft **D** 117 ft

45 Which expression can be used to find the n th term in the sequence below, where n represents the position of the term in the sequence?

−2, 1, 4, 7, 10

F $n + 3$ **H** $3n$

G $3n - 5$ **J** $2n + 1$

46 Which model matches the following problem?

Diana is sewing a quilt top that is 78 inches long and 60 inches wide.

She will add a 3-inch border to the two ends and a 2-inch border to the two sides. What will be the length and width of the finished quilt?

F 84 inches long and 64 inches wide

G 82 inches long and 66 inches wide

H 81 inches long and 62 inches wide

J 80 inches long and 63 inches wide

47 Mrs. Brand asked 25 students how many times they used a calculator while completing the same math assignment. Their responses are shown in the table.

Calculator Use

Number of Times Used	Number of Students
22	3
24	5
29	8
30	2
31	2
34	4
38	1

Which measure of central tendency does 29 represent?

A Mean **C** Median

B Mode **D** Range



Benchmark Test 2

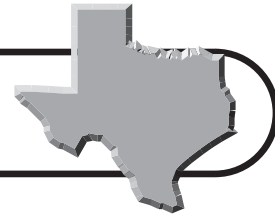

Read each question and choose the correct answer.

1 Which set of rational numbers shows equivalent values?

- A** $\frac{1}{5}$, 0.02, 20%
- B** $\frac{1}{4}$, 2.5, 25%
- C** $\frac{1}{8}$, 0.125, 12.5%
- D** $\frac{1}{3}$, 0.33, 33%

2 Which expression describes the relationship between a term and n , its position in the sequence?

Position	1	2	3	4	5	6	n
Term	-4	-1	4	11	20	31	

- F** $n^2 - 5$
- G** $2n - 5$
- H** $2n^2 + 5$
- J** $2n^2 - 5$

3 What polygon has 5 equal sides?

- A** Octagon
- B** Regular hexagon
- C** Irregular pentagon
- D** Regular pentagon

4 What solid figure is made by folding the net below?

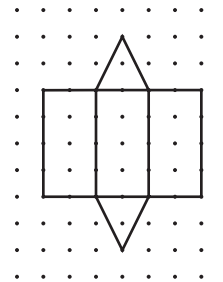

- F** Triangular prism
- G** Square pyramid
- H** Triangular pyramid
- J** Square prism

5 Mariah had scores between 86 and 99 in each of 6 rounds of golf. Which is the best estimate of her total score in 6 rounds?

- A** 280
- B** 360
- C** 550
- D** 670

6 How is a square different from a rhombus?

- F** It has 4 equal sides.
- G** It has perpendicular diagonals.
- H** All 4 angles are 90° .
- J** Opposite angles are congruent.



Benchmark Test 2 (continued)

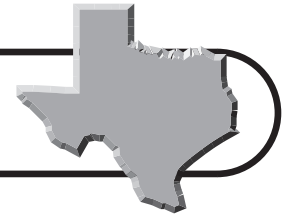

- 7 Which point on the grid below is at $(7, -7)$?

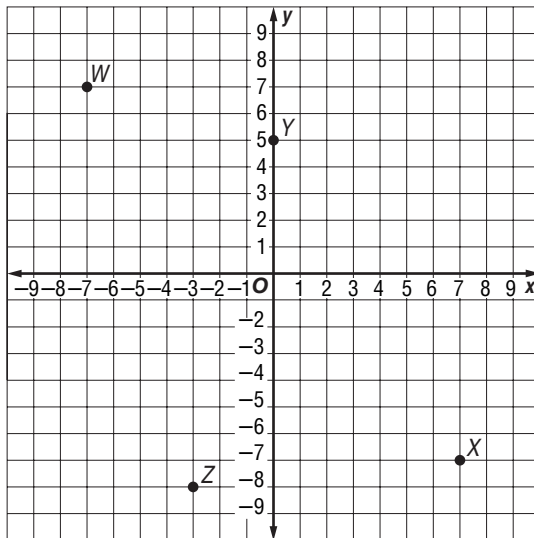

A *W*
B *X*

C *Y*
D *Z*

- 8 Kirk and his classmates went on a field trip to the State Capitol in Austin. Eight teachers and 136 students went on the trip. What was the student-to-teacher ratio?

F 1:17
G 17:1

H 4:34
J 68:2

- 9 Shannon's goal is to exercise for an hour each day. During the first week, she exercised 15 minutes each day. In Week 2, she increased the time to 30 minutes each day. If the pattern continues, in which week will she reach her exercise goal of one hour a day?

A Week 3
B Week 4

C Week 5
D Week 6

- 10 Robert needs to simplify the expression $18 - 4^2 \times 2 + 8$. Which operation will he do first?

F Add 2 and 8.
G Simplify 4^2 .
H Subtract 4^2 from 18.
J Multiply 2 by 4^2 .

- 11 Isabel drew a sketch of her flower garden. She wants to place edging around the garden. How many inches of edging does she need?

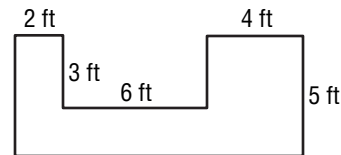

A 40 in.
B 48 in.
C 400 in.
D 480 in.

- 12 Which of the following does the model show?

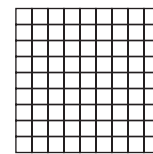

F $9^2 = 18$
G $9^2 = 81$
H $9^2 = 11$
J $9^9 = 91$

- 13 $\angle PQR$ and $\angle LMN$ are complementary angles. The measure of $\angle PQR$ is 60° . What is the measure of $\angle LMN$?

A 30°
B 60°
C 120°
D 240°



Benchmark Test 2 (continued)

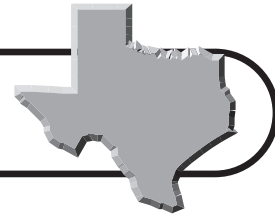

- 14** Melinda is cutting squares of different colored corkboard to make a bulletin board for her wall. Use the ruler on the Mathematics Chart to measure the sides of the square shown below to the nearest centimeter.

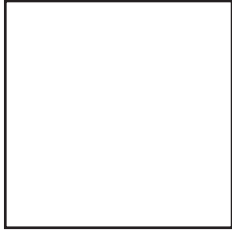

What is the area of the corkboard piece above?

- F** 18 cm^2
G 12 cm^2
H 9 cm^2
J 6 cm^2
- 15** Which expression is represented by the model below?
-
- A** $-8 + (-12)$
B $8 + (-12)$
C $(-8) + 12$
D $8 + 12$
- 16** Ushi made a vase in pottery class. Its base has a diameter of 8 centimeters. Which expression can be used to find the circumference of the base?
- F** 8π
G $8 - \pi$
H $4\pi^2$
J 16π

- 17** Which of the following situations represents the greatest percent of change?
- A** The cost of a postage stamp increased from 37¢ to 39¢ .
B A kitten grew from 2 pounds to 8 pounds in one year.
C A jacket that a store bought wholesale for $\$30.00$ is sold for $\$60.00$.
D A person who diets went from a 40-inch waist to a 32-inch waist in one year.
- 18** Anika has 2 dimes, 3 nickels, and 4 pennies in a jar on her desk. Which list shows all of the possible outcomes if Anika chooses 3 coins from the jar without looking?

F

Coin Combinations		
dime	dime	nickel
dime	dime	penny
dime	nickel	nickel
dime	penny	penny
dime	nickel	penny
nickel	nickel	nickel
nickel	nickel	penny
nickel	penny	penny
penny	penny	penny

G

Coin Combinations		
dime	dime	nickel
dime	dime	penny
dime	nickel	nickel
dime	penny	penny
dime	nickel	penny
nickel	nickel	nickel
nickel	penny	penny
penny	penny	penny



Benchmark Test 2 (continued)

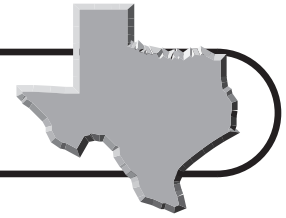

H

Coin Combinations		
dime	dime	dime
dime	dime	penny
dime	nickel	nickel
dime	penny	penny
dime	nickel	penny
nickel	nickel	nickel
nickel	nickel	penny
nickel	penny	penny

J

Coin Combinations		
dime	dime	nickel
dime	dime	penny
dime	nickel	penny
dime	penny	penny
dime	nickel	penny
nickel	nickel	nickel
nickel	nickel	penny

19 Casey bought a notebook for \$0.99, a calendar for \$8.99, and some books. He received \$4.28 in change. What information is needed to find the cost of the books?

- A** The cost of one book
- B** The number of books he bought
- C** The amount of money he gave the cashier
- D** The amount of money he has in his pocket

20 Simplify the expression below.

$$4^2 \div 2 - 2^2 + 3$$

- F** 2
- G** 3
- H** 7
- J** 9

21 Which situation matches the equation below?

$$\frac{x + 4.2 + 3.8 + 4.5}{4} = 4.25$$

- A** Carl bought 3 books. The average cost of the books was \$4.25. What is x , the amount of tax he paid?
- B** Elise measured the lengths of 4 worms for a science experiment. The average length of the worms was 4.25 centimeters. What is x , the length of the first worm?
- C** Jessie went for a walk 4 days in a row. She walked a total of 4.25 miles. What is x , the distance she walked on the fourth day?
- D** Kelvin bought 4 boxes of cereal. Each box cost between \$3.80 and \$4.50. What is x , the average cost for a box of cereal?

22 The science test scores of 8 students are shown below.

86, 72, 91, 89, 83, 96, 78, 84

What is the median test score?

- F** 83
- G** 84
- H** 85
- J** 86



Benchmark Test 2 (continued)

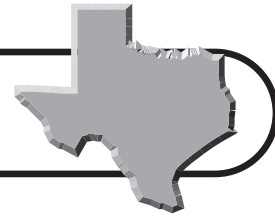

- 23** The graph below shows the average amount of money visitors from other countries spend per person when visiting the state of Texas.

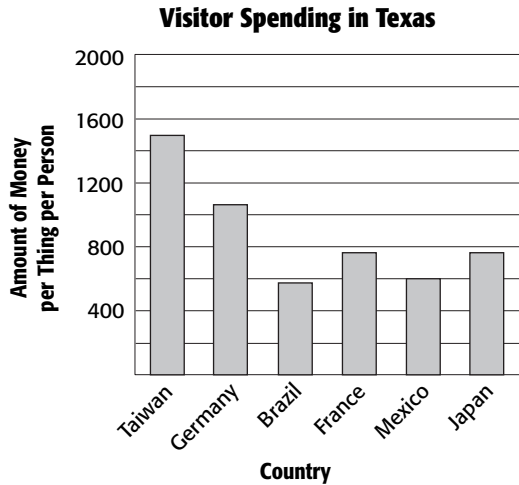

Which statement is best supported by these data?

- A** People from Taiwan spend more money per trip than people from other countries.
- B** People from Germany and Japan spend about the same amount of money per trip.
- C** People from Mexico spend about twice as much money as people from Brazil.
- D** People from France spend about half as much money as people from Germany.

- 24** The fraction $\frac{3}{7}$ is found between which pair of fractions on a number line?

- F** $\frac{4}{14}$ and $\frac{8}{21}$
- G** $\frac{5}{14}$ and $\frac{10}{21}$
- H** $\frac{6}{14}$ and $\frac{9}{21}$
- J** $\frac{7}{14}$ and $\frac{11}{21}$

- 25** Mr. Gonzalez is making a cover for a children's sandbox. The dimensions of the sandbox are 96 inches long and 72 inches wide. He is making a cover that will hang 2 inches over the edge of the sandbox on all sides. What will be the area of the cover in square inches?

Record your answer and fill in the bubbles on the grid below. Be sure to use the correct place value.

0	0	0	0	.	0	0
1	1	1	1		1	1
2	2	2	2		2	2
3	3	3	3		3	3
4	4	4	4		4	4
5	5	5	5		5	5
6	6	6	6		6	6
7	7	7	7		7	7
8	8	8	8		8	8
9	9	9	9		9	9

- 26** Which solid figure is shown?

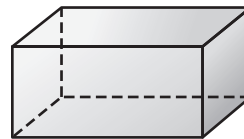

- F** Rectangular pyramid
- G** Rectangular prism
- H** Rectangular cone
- J** Cube



Benchmark Test 2 (continued)

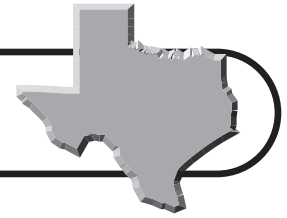

- 27** The data in the table represent the relationship between quarts and pints.

Number of Quarts	Number of Pints
1	2
2	4
3	6
4	8

Which graph matches the data in the table above?

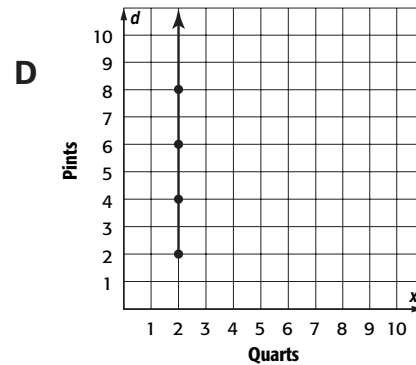
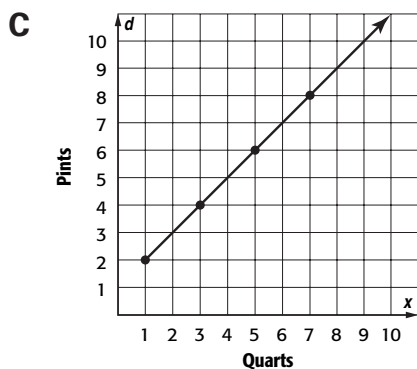
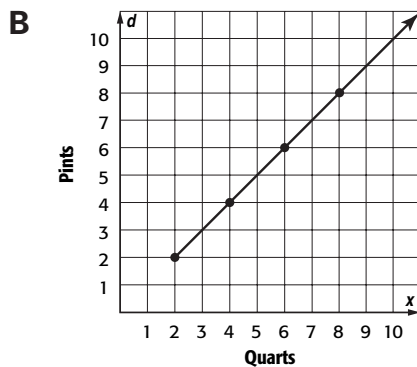
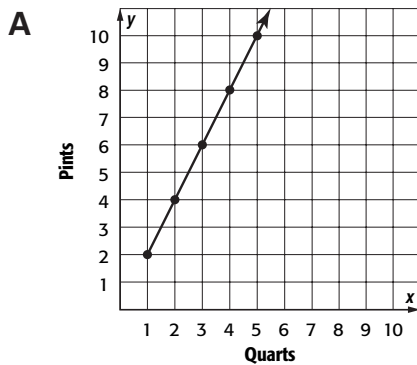

- 28** Erika bought supplies to knit scarves for her sisters. She bought skeins of yarn for \$3.50 each, 2 bags of beads for \$1.99 each, and 2 sets of knitting needles for \$15.00. The total before tax was \$29.48. She gave the cashier \$32.00 and received \$0.95 in change. Which of the following questions cannot be answered with the information provided?
- F** How many skeins of yarn does Erika need for each scarf?
 - G** How much did each set of knitting needles cost?
 - H** What was the total amount for the beads?
 - J** What was the amount of tax on her purchase?

- 29** Sandy wants to make a flower bed that is 24 square feet. Which of the following cannot be the dimensions of her flower bed?

- A** 8 ft by 3 ft
- B** 2 ft by 1 ft
- C** 4 ft by 6 ft
- D** 5 ft by 5 ft



Benchmark Test 2 (continued)

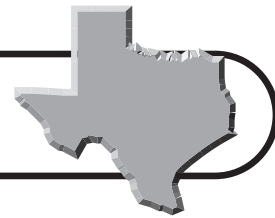

- 30** Luke rode his bicycle $25\frac{1}{4}$ miles each day for five days. If he continues to ride at the same rate, how many miles will he ride his bicycle in a week?

F $126\frac{1}{4}$ mi

G $151\frac{1}{2}$ mi

H $176\frac{3}{4}$ mi

J 202 mi

- 31** The top, side, and front views of a solid figure are shown below.

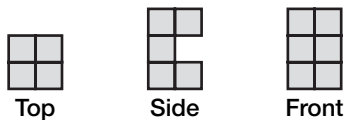

Which solid figure is best represented by these views?

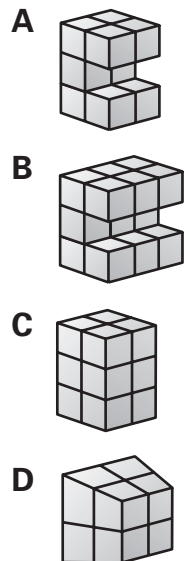

- 32** Annabeth mixed 2 pints of red paint with 5 pints of blue paint to make a shade of purple. Which equation can be used to find x , the percent of blue paint in the paint mixture?

F $\frac{5}{7} = \frac{x}{100}$

G $\frac{2}{5} = \frac{x}{100}$

H $\frac{5}{2} = \frac{100}{x}$

J $\frac{5}{7} = \frac{100}{x}$

- 33** Derek has 3 baseball cards that are worth \$12 each. He also has 1 baseball card worth \$20.00 and 2 that are worth \$50.00 each. What is the total value of Derek's 6 baseball cards?

A \$82.00

B \$132.00

C \$144.00

D \$156.00

- 34** Lila painted a picture to be displayed at an art show like the picture below. Each square on the grid represents 4 square inches. What is the approximate area of the shaded part of the painting?

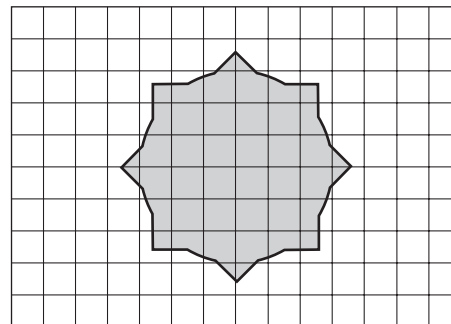

F 144 in^2

G 120 in^2

H 104 in^2

J 88 in^2



Benchmark Test 2 (continued)

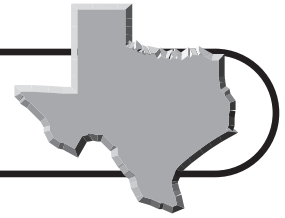

- 35** Aldon recorded the outside temperature each day at 4:00 P.M. for a week. He wants to show how much the temperature changes from day to day. Which of the following graphs best displays the change in temperature from day to day?

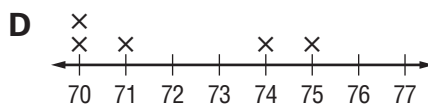
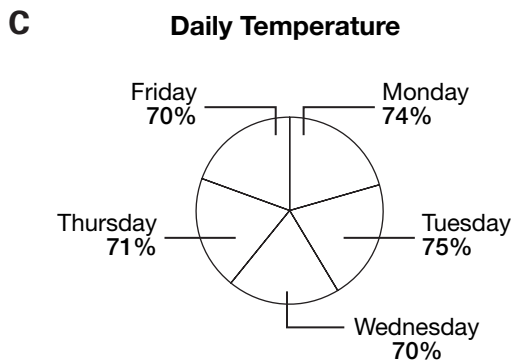
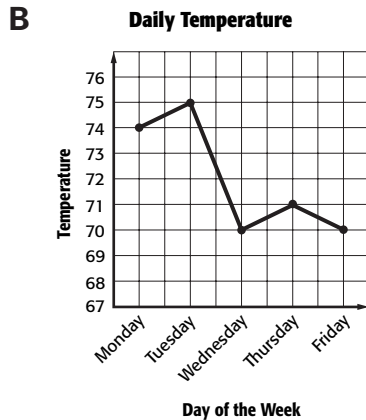
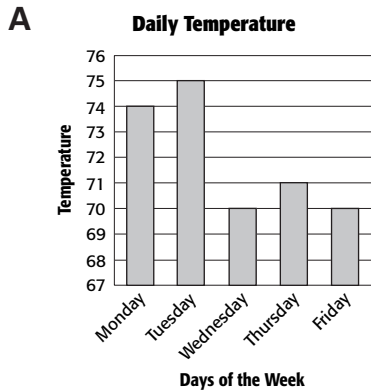

- 36** Samantha scored 8, 12, 6, 6, and 14 points in her first five basketball games. How many points must she score in her sixth game so that the median of the points she scores is 10?

F 8
G 9
H 10
J 12

- 37** A number cube for a game is numbered 7–12. Which of these lists shows all of the possible outcomes?

A 7, 9, 11
B 8, 9, 10, 11
C 7, 8, 9, 10, 11, 12
D 8, 10, 12

- 38** Alexis has a 24-piece pack of chewing gum. She wants to share the pieces of gum equally among her three friends and herself. Which expression can Alexis use to find how many pieces of gum she will give to each friend?

F 24×4
G $24 \div 4$
H $24 \div 3$
J 24×3

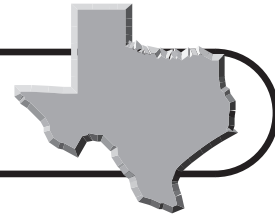

Benchmark Test 2 (continued)

- 39** Ben bowled 5 games. His scores were 98, 155, 98, 122, and 118. Which measure of central tendency would make Ben's scores appear to be lower than they actually are?

A Mean
B Median
C Mode
D Range

- 40** Dacia is comparing the prices of different boxes of spaghetti noodles. The sizes and prices of 4 different boxes are shown in the table.

Brand	Size	Cost
Noodles Now	16 oz	\$1.08
Spaghetti Tonite	7 oz	\$0.54
Pasta Perfecto	24 oz	\$1.92
Panini's Pasta	32 oz	\$1.79

Which brand of spaghetti noodles should Dacia buy to get the best value?

F Noodles Now
G Spaghetti Tonite
H Pasta Perfecto
J Panini's Pasta

- 41** Which sequence follows the rule $2n^2 - 10$, where n represents the position of a term in the sequence?

A $-8, 2, 4, 10, 16, \dots$
B $-8, -2, 8, 22, 40, \dots$
C $-9, -6, -1, 6, 15, \dots$
D $-9, 1, 11, 21, 31, \dots$

- 42** Sharon has a cylindrical-shaped glass candleholder. She is decorating the outside of the glass by wrapping a string of beads around the bottom of its base 5 times. The base of the candleholder has a diameter of 4 inches. How long will the string of beads need to be?

F 12.56 in.
G 25.12 in.
H 31.4 in.
J 62.8 in.

- 43** Sean is designing a steering wheel for his go-cart. The inside diameter of the steering wheel must be at least 12 inches, and the thickness cannot be greater than 3 inches. What strategy can best help Sean determine the outside diameter of the steering wheel?

A Solving a simpler problem
B Making a drawing or a model
C Looking for a pattern
D Making a table



Benchmark Test 2 (continued)

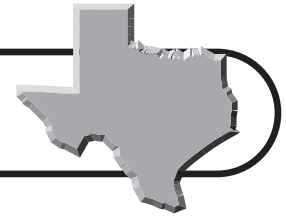

Grace collected the following data during a science experiment. Use this information to answer questions 44–45.

Paper Airplane Throw

Trial	Flying Time (in seconds)
1	5
2	3
3	7
4	3
5	5
6	2

44 Which measure of central tendency does 4 represent?

- F** Mean
- G** Median
- H** Mode
- J** Range

45 What is the range of the data Grace collected?

- A** 7
- B** 5
- C** 4
- D** 3

46 Mr. Presser bought a gallon of paint for \$20.95, two paintbrushes for \$2.95 each, a paint tray for \$0.99, and a paint scraper for \$4.15. The tax is 8%. What is a good estimate of the amount of tax that Mr. Presser paid?

- F** \$1.50
- G** \$2.00
- H** \$2.50
- J** \$3.00

47 Quadrilateral $LMNO$ is similar to quadrilateral $WXYZ$. The scale factor of quadrilateral $LMNO$ to quadrilateral $WXYZ$ is 4:5. If \overline{MN} is 14 inches, what is the length of \overline{XY} ?

- A** 14.4 in.
- B** 17.5 in.
- C** 22.5 in.
- D** 42.8 in.

48 Which expression can be used to find the n th term in the sequence below, where n represents the position of the term in the sequence?

6, 9, 14, 21, 30

- F** $2n^2 + 3$
- G** $2n + 4$
- H** $n^2 - 1$
- J** $n^2 + 5$



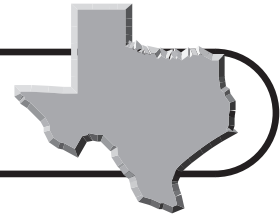

Benchmark Test 3

Read each question and choose the best answer.

1 Which set of rational numbers does NOT show equivalent values?

- A** $\frac{3}{8}$, 0.375, 37.5%
- B** $\frac{2}{5}$, 0.40, 4%
- C** $\frac{3}{4}$, 0.75, 75%
- D** $\frac{4}{5}$, 0.80, 80%

2 Which expression describes the relationship between a term and n and its position in the sequence?

Position	1	2	3	4	5	n
Term	-7	0	19	56	117	

- F** $n - 8$
- G** $2n^3 + 4$
- H** n^3
- J** $n^3 - 8$

3 Darius drew a sketch of the dollhouse he plans to build for his younger sister.

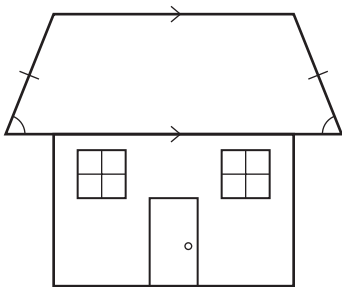

Which of the following best describes the shape of the roof?

- A** Rhombus
- B** Parallelogram
- C** Trapezoid
- D** Kite

4 Katie is making a cylindrical-shaped container to collect aluminum can tops for a charity. Which net can she use to make the cylinder?

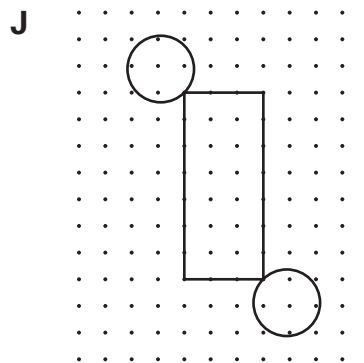
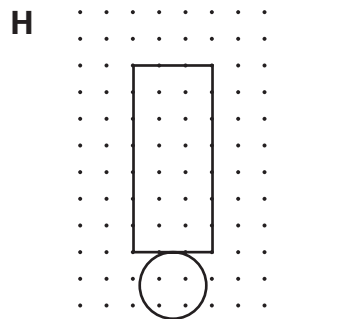
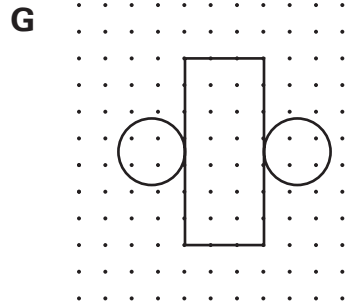
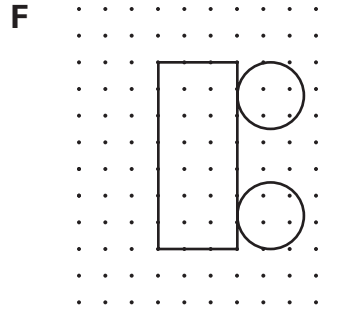

Benchmark Test 3 (continued)

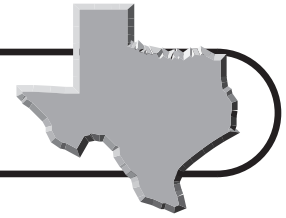

- 5 Manuela swims the 200-meter individual medley in competition. The medley consists of 50 meters for each of the following strokes: butterfly, backstroke, breaststroke, and freestyle. Her split times for each of the strokes were between 28 and 38 seconds. Which is the best estimate of her time in the individual medley?
- A** 100 sec
B 140 sec
C 190 sec
D 220 sec

- 6 Which line on the grid below contains the ordered pair $(7, -5)$?

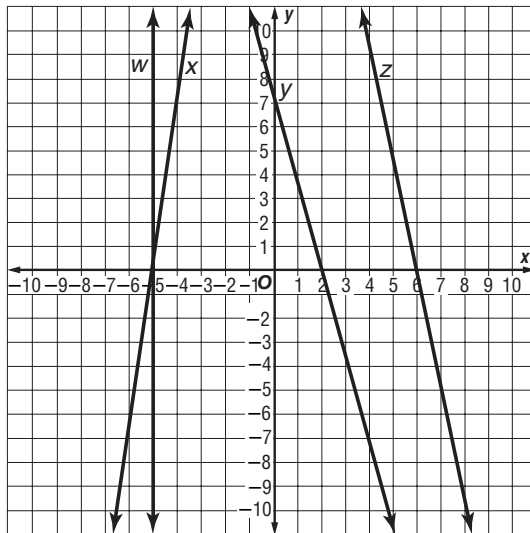

- F** Line w
G Line x
H Line y
J Line z

- 7 One hundred ninety-eight seventh-grade students and 9 teachers went on a field trip to the Johnson Space Center. What was the student-to-teacher ratio?

- A** 9:202
B 202:9
C 1:22
D 22:1

- 8 If the following pattern continues, in which step will there be fewer than 20 shaded triangles?



Step 1



Step 2



Step 3

- F** Step 4
G Step 5
H Step 6
J Step 7

- 9 Natasha will simplify the expression $3^2 \times (5 + 8) \div 4$. Which operation will she carry out first?

- A** Multiply 3 by 3.
B Add 5 and 4.
C Add 5 and 8.
D Divide 8 by 4.



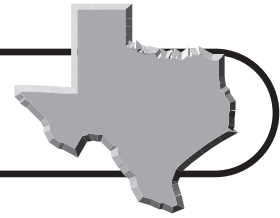

Benchmark Test 3 (continued)

- 10** A new apartment complex is constructing a swimming pool. According to Texas regulations, there must be a 4-foot high fence enclosing the pool area. The drawing below shows the planned pool and fence enclosure. What will be the perimeter of the fence?

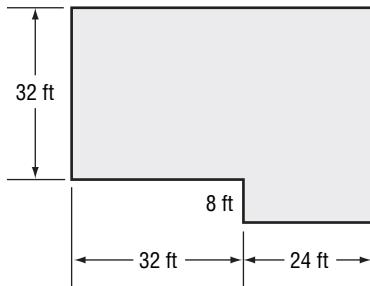

- F** 56 ft
- G** 96 ft
- H** 192 ft
- J** 768 ft

- 11** Which model best represents 7^2 ?

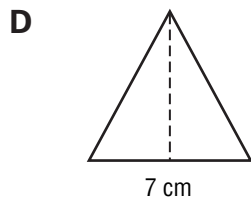
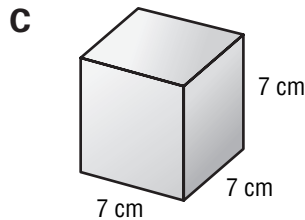
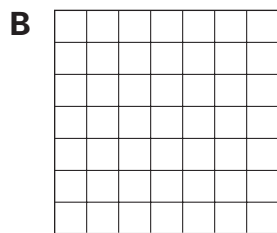
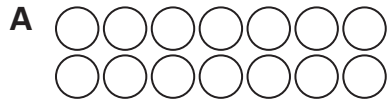

- 12** $\angle M$ and $\angle N$ are supplementary angles. The measure of $\angle M$ is 82° . What is the measure of $\angle N$?
- F** 8°
 - G** 18°
 - H** 38°
 - J** 98°

- 13** Seth is hanging plastic circles on strings to make a curtain for his room. Use the ruler on the Mathematics Chart to measure the diameter of the circle shown below to the nearest centimeter.

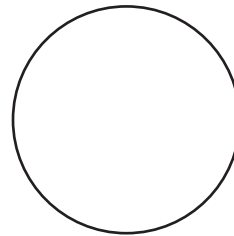

Which of the following is closest to the area of the circle? Use 3.14 for π .

- A** 2.25 cm^2
- B** 3 cm^2
- C** 7 cm^2
- D** 28.2 cm^2

- 14** Which expression is represented by the model below?

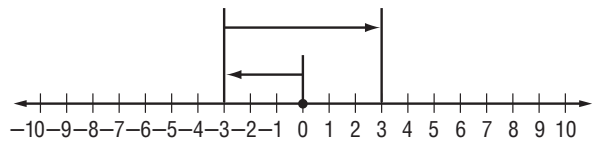

- F** $-6 + (-3)$
- G** $3 - 6$
- H** $(-3) + 6$
- J** $6 + (-3)$



Benchmark Test 3 (continued)

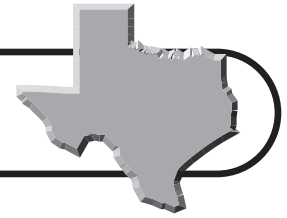

- 15** Donna's mother made her a hoop skirt for a 50's dance. The radius of the hoop is $1\frac{1}{2}$ feet. Which expression can be used to find the circumference of the hoop?

A $\frac{3}{\pi^2}$
B 3π
C $3\pi^2$
D $\frac{\pi}{3}$

- 16** Which of the following situations represents the greatest percent of change?

F A skirt is discounted from \$24.00 to \$18.00.
G A 175-pound person loses 12 pounds.
H A monthly telephone bill increases from \$34.00 to \$36.00.
J The population of a small town increases from 325 to 350.

- 17** Tabea has 4 red marbles, 3 blue marbles, and 1 white marble in a shoebox. Which list shows all of the possible outcomes if Tabea draws 3 marbles out of the shoebox without looking?

A

Marble Combinations		
red	red	blue
red	red	white
blue	blue	blue
blue	blue	red
blue	blue	white
red	red	red

B

Marble Combinations		
red	red	red
red	red	blue
red	red	white
red	blue	white
blue	blue	blue
blue	blue	red
blue	blue	white
white	white	red
white	white	blue

C

Marble Combinations		
red	red	red
red	red	blue
blue	blue	blue
blue	blue	red
blue	blue	white
white	white	red

D

Marble Combinations		
red	red	red
red	red	blue
red	red	white
red	blue	white
blue	blue	blue
blue	blue	red
blue	blue	white



Benchmark Test 3 (continued)

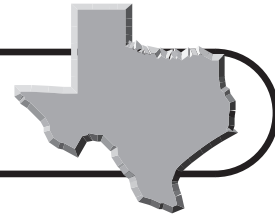

- 18** A clothing store owner bought some sweaters and then sold them in the store for \$34.00 each. She sold 12 sweaters on Thursday, 16 on Friday, and 28 on Saturday. What information is needed to find the amount of profit she made from the sale of the sweaters on Thursday, Friday, and Saturday?
- F** The total number of sweaters sold
G The number of sweaters that were sold on Sunday
H The number of sweaters she bought
J The amount of money she paid for the sweaters

- 19** Simplify the expression below.

$$(42 + 7) - 2 \times 5 + 8$$

- A** -3
B 21
C 49
D 113
- 20** Which situation matches the equation $2x + 3y = 25.25$?
- F** What is the perimeter of a rectangle with a length of 2 meters, a width of 3 meters, and an area of 25.25 m^2 ?
- G** Sixty pairs of sunglasses are being shipped in boxes. Some boxes hold 2 pairs of sunglasses and other boxes hold 3 pairs of sunglasses. How many of each type of box are needed?
- H** At the store, Sharon spends \$25.25. She buys 2 pounds of lunchmeat and 3 bags of crackers. How much does one pound of lunchmeat and 1 bag of crackers cost?
- J** A group of children and adults went to a play. Tickets for adults are \$6.25 and tickets for children are \$4.25. How many adults and how many children went to the play?

- 21** The ages of 10 students at Randall Middle School are shown below.

13, 13, 14, 12, 12, 13, 14, 14, 11, 14

Which is the mean age of the students?

- A** 11
B 12
C 13
D 14
- 22** The graph below shows where people traveling in Texas in 2004 spent their money.

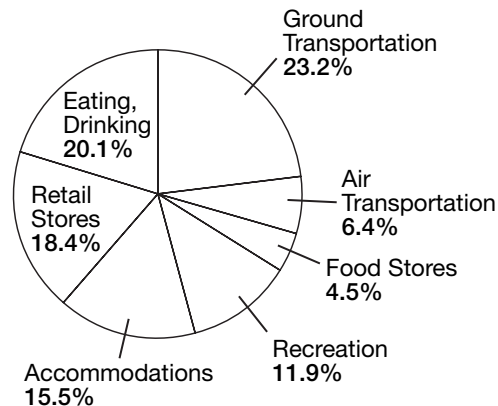

Which statement is best supported by these data?

- F** The amount of money travelers spent on eating, drinking, and in food stores was more than the amount spent on ground and air transportation.
- G** Travelers spent the least amount of money in retail stores.
- H** More travelers spent money eating and drinking than they did on ground transportation.
- J** Travelers spent slightly more on ground transportation than they did on eating and drinking.



Benchmark Test 3 (continued)

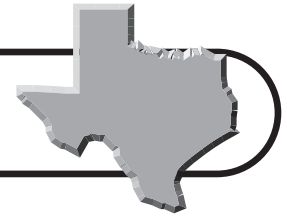

23 The fraction $\frac{4}{5}$ is found between which pair of fractions on a number line?

- A** $\frac{7}{10}$ and $\frac{17}{20}$
B $\frac{8}{10}$ and $\frac{16}{20}$
C $\frac{9}{10}$ and $\frac{18}{20}$
D $\frac{7}{10}$ and $\frac{15}{20}$

24 Siri sewed a rectangular tablecloth. The dimensions of the tablecloth are 92 inches long and 58 inches wide. What is the area of the tablecloth in square inches?

Record your answer and fill in the bubbles on the grid below. Be sure to use the correct place value.

0	0	0	0	.	0	0
1	1	1	1		1	1
2	2	2	2		2	2
3	3	3	3		3	3
4	4	4	4		4	4
5	5	5	5		5	5
6	6	6	6		6	6
7	7	7	7		7	7
8	8	8	8		8	8
9	9	9	9		9	9

25 Which solid figure has 2 parallel congruent bases that are polygons?

- A** Cone
B Pyramid
C Prism
D Cylinder

26 Which of the following relationships matches the data in the graph?

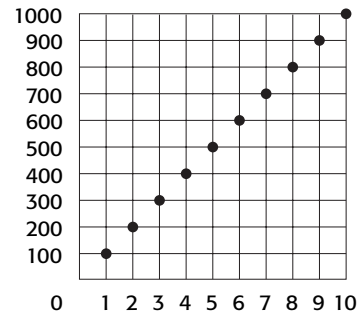

- F** Centimeters to kilometers
G Meters to centimeters
H Millimeters to centimeters
J Meters to millimeters

27 Jose made a rectangular toy box for his children. The toy box is 3 feet long, 2 feet wide, and 2 feet high, and it is divided into 3 sections. $\frac{1}{3}$ of the toy box is used for storing games. Which of the following questions cannot be answered with the information provided?

- A** What is the volume of the toys in the toy box?
B What is the area of the bottom of the toy box?
C What is the perimeter of the toy box?
D What is the volume of the toy box used for games?



Benchmark Test 3 (continued)

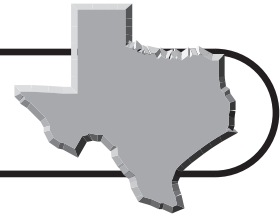

- 28** Lena and her father are using cylinder-shaped forms to make cement footings for a new porch. The forms have a diameter of 14 inches. What is the area the base of each footing will cover on the ground? Use 3.14 for π .

F 43.96 in²
G 87.92 in²
H 153.86 in²
J 615.44 in²

- 29** Storm has three lengths of rope that are each $10\frac{2}{3}$ yards long. How many yards of rope does he have in all?

A $30\frac{1}{3}$ yd
B 32 yd
C $32\frac{2}{3}$ yd
D 33 yd

- 30** A 35-pound bag of dog food contains 14 pounds of meat. Which equation can be used to find x , the percent of meat in the dog food?

F $\frac{14}{49} = \frac{x}{100}$
G $\frac{14}{35} = \frac{x}{100}$
H $\frac{35}{49} = \frac{100}{x}$
J $\frac{35}{14} = \frac{x}{100}$

- 31** The top, side, and front views of a solid figure are shown below.

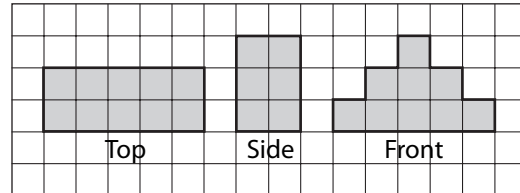

Which solid figure is best represented by these views?

- A**
- B**
- C**
- D**

- 32** Sally earns \$9.50 an hour working as a lifeguard. She worked 6 hours on Monday, 7.5 hours on Tuesday, 5.5 hours on Wednesday, and 6 hours on Thursday. How much money did she earn in the 4 days?

F \$228.00
G \$237.50
H \$250.00
J \$258.50



Benchmark Test 3 (continued)

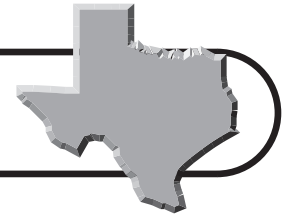

- 33** In the sketch below, the shaded area represents the parts of a garden where Mrs. Waverly plans to plant Texas wildflowers.

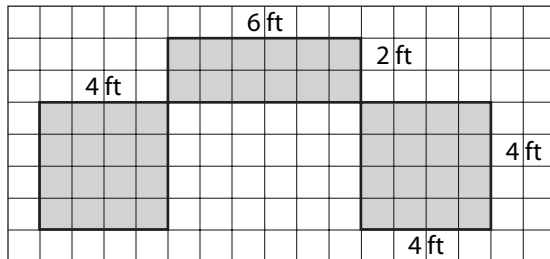

What is the area of the garden that will have wildflowers?

- A** 28 ft^2
B 32 ft^2
C 44 ft^2
D 48 ft^2
- 34** On his first four science tests, Keith scored 75, 86, 79, and 91. What score must he receive on the fifth science test to have a mean score of 85 for the five tests?
- F** 85
G 88
H 91
J 94

- 35** Sergei surveyed 20 classmates to find out how many students participate in sports, academic clubs, or both. Which of the following gives the most information about individual students and the clubs in which they participate?

A Types of Clubs Students Participate In

Type of Club	Number of Students
Academic	8
Sports	15
Both	4

B Types of Clubs Students Participate In

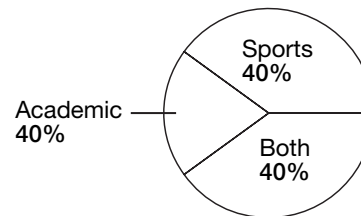

C Types of Clubs Students Participate In

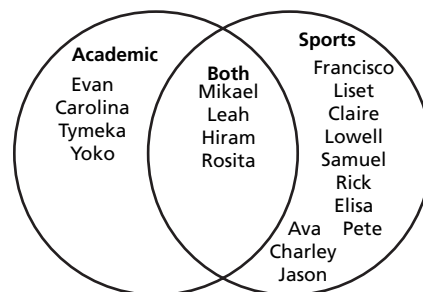

D Types of Clubs

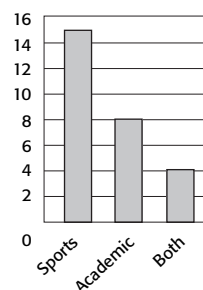

Benchmark Test 3 (continued)

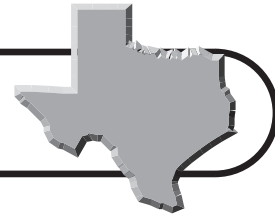

- 36** Erik has two fair spinners. One has 4 sections and is numbered 1 to 4. The second has 3 sections and is lettered A to C. Erik spins the two spinners at the same time and records the results. What was the sample space of spinning the two spinners?
- F** 1, 2, 3, 4
G 1, 2, 3, 4, A, B, C
H 1-A, 2-A, 3-A, 4-A, 2-B, 3-B, 4-B, 3-C, 4-C
J 1-A, 2-A, 3-A, 4-A, 1-B, 2-B, 2-C, 2-D, 3-A, 3-B, 3-C, 3-D, 4-A, 4-B, 4-C, 4-D
- 37** An electric company ships its light bulbs in boxes that hold 588 light bulbs. The light bulbs are in packages of 4. Which expression can be used to find the number of packages in each box?
- A** $588 + 4$
B 588×4
C $588 \div 4$
D $588 - 4$

- 38** Trey ran 1 mile on Monday, 3 miles on Tuesday, 1 mile on Wednesday, 5 miles on Thursday, and 6 miles on Friday. Which measure of central tendency would make it appear as though Trey runs fewer miles each day on average than he actually does?
- F** Mean
G Mode
H Median
J Range

- 39** Before buying potatoes at a farmer's market, Jerron is comparing the prices of different vendors.

Vendor	Size of Bag	Cost
Eugster's Farm	1 lb	\$1.39
Schmidt's Country Market	3 lb	\$1.79
Phillips' Potato Patch	5 lb	\$2.79
Jensen's Barn	10 lb	\$4.29

From which vendor should she buy potatoes in order to save the most money per pound of potatoes?

- A** Eugster's Farm
B Schmidt's Country Market
C Phillips' Potato Patch
D Jensen's Barn
- 40** Which sequence follows the rule $n^3 + 1$, where n represents the position of a term in the sequence?
- F** 2, 5, 10, 17, 26, ...
G 2, 8, 27, 64, 125, ...
H 2, 9, 28, 65, 126, ...
J 1, 7, 26, 63, 124, ...



Benchmark Test 3 (continued)

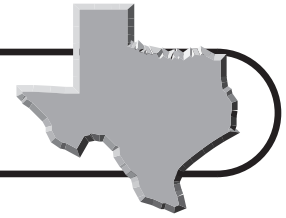

41 Jasmin measures the base of a flowerpot to find out whether it will fit on a shelf. The base of the flowerpot has a diameter of 12 inches. What is the circumference of the flowerpot? Use 3.14 for π .

- A** 18.84 cm
- B** 37.68 cm
- C** 75.36 cm
- D** 113.04 cm

42 Allie is planting flowers in a rectangular flowerbed that is 180 inches long and 36 inches wide. She wants to place flowers every 2 inches to fill the flowerbed. Which strategy can best help Allie determine how many flowers she needs to buy?

- F** Work backward
- G** Look for a pattern
- H** Solve a simpler problem
- J** Make a drawing or a model

43 Kyle throws the shot put for the track and field team. The table below shows the distances of 6 of his practice throws one day.

Shot Put Throws

Throw	Distance (ft)
1	42
2	38
3	48
4	44
5	34
6	38

Which measure of central tendency does 38 represent?

- A** Mean
- B** Median
- C** Mode
- D** Range

44 Which expression can be used to find the n th term in the sequence below, where n represents the position of the term in the sequence?

–2, 4, 14, 28, 46

- F** $2n^2 - 4$
- G** $2n + 4$
- H** $n^2 + 14$
- J** $2n - 8$

45 Jodie bought two boxes of file folders for \$2.29 each, a package of notepads for \$4.89, a box of paper clips for \$0.99, and 2 packages of pens for \$2.99 each. The tax is 8%. What is a good estimate of the total amount paid by Jodie?

- A** \$18.00
- B** \$20.00
- C** \$22.00
- D** \$24.00

46 Parallelogram $QRST$ is similar to parallelogram $ABCD$. The scale factor of parallelogram $QRST$ to parallelogram $ABCD$ is 2:9. If \overline{ST} is 12 centimeters, what is the length of \overline{CD} ?

- F** 11 cm
- G** 18 cm
- H** 54 cm
- J** 108 cm

