

Conserving and Recycling

Be Conservation Conscious



Directions: Read the story below about Jeremy and his mother. On the lines below, suggest ten ways that Jeremy and his mother could conserve or recycle resources.

“We’re out of milk,” called Jeremy to his mother as he tossed the plastic milk jug in the waste basket. She came into the kitchen and said, “I’ll have to run to the supermarket before supper to get some. I just went to the store last night—I wish I’d gotten it then.” As his mother got her keys and purse, Jeremy peeked in the oven and asked, “What’s for dinner?” His mother said, “Meatloaf,” as she went out the door. Jeremy held the oven door open for a minute, being warmed by the heat. He decided to get a drink of water. He turned on the water so it would cool and got a paper cup to drink from. As he filled the cup, he spilled some water on the floor. He got out a roll of pink plaid paper towels and wiped up the water. His mother walked in from the store. She had a jug of milk and a box of frozen corn for supper. After she took the groceries out of the bag, she handed the bag to Jeremy to throw away. “Will you set the table, Jeremy?” she said, “and I’ll get the potatoes and corn heating on the cooktop.”

1. _____
2. _____
3. _____
4. _____
5. _____
6. _____
7. _____
8. _____
9. _____
10. _____

Conserving and Recycling

Conserve Our Resources

Directions: Listed below are clues that relate to conserving resources. Use each clue to complete the blank spaces in the corresponding numbered item.

1. _____ C _____
2. _____ O _____
3. _____ N _____
4. _____ S _____
5. _____ E _____
6. _____ R _____
7. _____ V _____
8. _____ E _____

Clues

1. This makes up a large portion of trash.
2. This can create a water shortage.
3. A place where trash is normally buried.
4. This substance is made from petroleum.
5. This can pollute water if too much is used.
6. This will be improved by conserving and recycling.
7. Keep this door closed to save fuel when preparing food.
8. When people do this, new products are made from the materials of old ones.

Microwave Techniques

Using the Microwave

Directions: Read each situation described below.
Answer the question on the lines provided.

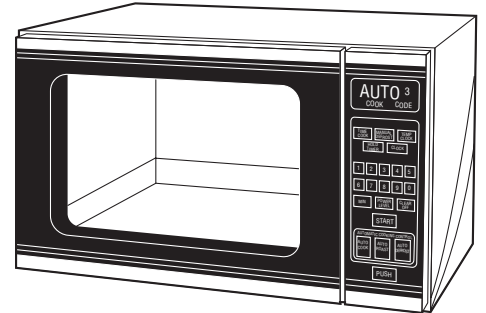

1. Your microwave oven has 900 watts of cooking power. The recipe you are using calls for an oven of 500-700 watts. How would you need to adjust the cooking time? Why?

2. The paper towel you have wrapped around the hotdog you are ready to heat in the microwave does not say "microwave-safe." Should you use it anyway? Why or why not?

3. You are preparing a casserole to cook in the microwave. You have two glass casserole dishes: a round one and a square one. Which should you choose? Why?

4. You want to heat a bun for your sandwich in the microwave. The last time you heated a bun, it ended up being hard as a rock. How can this be prevented?

5. Your microwave has "hot spots." How might you move potatoes to be sure they are thoroughly baked in the microwave?

Microwave Techniques

The Microwave File

Directions: The numbers beneath the answer blanks below correspond to the numbers on the drawers of the filing cabinet. Find the file drawer that corresponds with the number below the blank. Then determine which of the letters on the file drawer you need to spell the correct word. Write that letter in the appropriate space. If you think you know the term from the clue alone, use the file drawer numbers to check your accuracy.

1. This is a major advantage of cooking with a microwave.

6 1 6 2 6 6 3 4 2

2. A type of food often made especially for microwave cooking.

1 5 4 6 2 4 3 2 4 1 2

3. What food molecules do when penetrated by microwaves.

6 3 1 5 1 6 2

4. Materials used in the microwave should have this label.

4 3 1 5 5 7 1 6 2 - 6 1 2 2

5. This material should be used in the microwave as recommended in the owner's manual.

1 4 6 4 3 4 6 4 2 5 3 4

6. Food cooked in the microwave should be in this kind of pieces.

6 4 3 2 5 5 4

7. Use this to cover food when microwaving if you want to hold in moisture.

6 5 6 3 2 2 - 2 5 7 4 5 4 1 6 2

8. This action will help food heat evenly in the microwave.

5 5 6 1 6 2 2 3 6 3

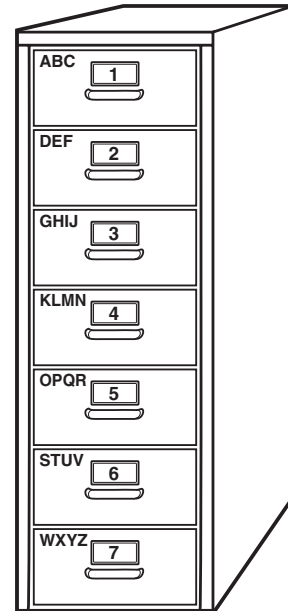

Using Kitchen Appliances

Identifying Small Appliances

Directions: Several small appliances are pictured below. The names of these appliances are given in scrambled form. Unscramble each word and write it in the blank above the appliance it names.

xrmei

tcieclr tleksil

rasttoe

aosrett vnoe

wlos orckoe

dofu sproscroe

dreenlb

1. _____

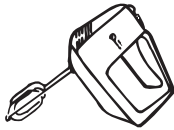

2. _____

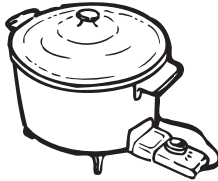

3. _____

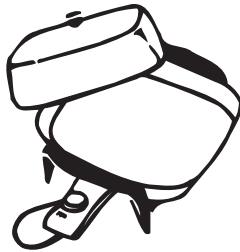

4. _____

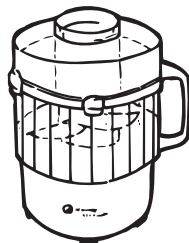

5. _____

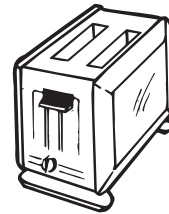

6. _____



7. _____

